

Bladder-type accumulator

Model HAB

RA 50175

Edition: 01.2017

Replaces: 09.2016



Component series 7X

Nominal volume 1 quart to 15 gallons

Maximum operating pressure 6000 PSI

Features

Hydraulic accumulator according to ASME Section VIII pressure vessel code or CRN/TSSA certification.

Bladder material for different applications

Use:

- Energy storage in systems with intermittent operation
- Energy reserve for emergencies
- Compensation for leakage losses
- Impact and vibration damping
- Compensation of flow in the case of changes in pressure and temperature

For complete details on HAB-6X design for applications requiring CE certification, refer to data sheet RE 50171.

Contents

Ordering code	2
Preferred models HAB-7X	3
Function, sectional drawing	4
Application, mode of operation	5
Technical data	6
Sizing calculations	7
Dimensional drawings	10
Accessories for BSPP fluid ports	15
Accessories for SAE fluid ports	16
Clamps and brackets	17
Pressure monitoring	20
Filling and test device	21
Installation & operating instructions	22
Spare parts information	22

Ordering code

01	02	03	04	05	06	07	08	09	10	11	12	13						
HAB		-		-	7X	/	0			-	2			1		1	-	

01	Bladder-type accumulator	HAB
----	--------------------------	------------

Nominal volume (L)

02	1 liter = (1 quart)	1
	4 liters = (1 gallon)	4
	10 liters = (2.5 gallons)	10
	20 liters = (5 gallons)	20
	35 liters = (10 gallons)	35
	57 liters = (15 gallons)	57

Maximum operating pressure

03	207 bar (3000 PSI)	207
	275 bar (4000 PSI)	275
	345 bar (5000 PSI, 10, 20, 35 and 57 liter only)	345
	414 bar (6000 PSI, 10, 20, 35 and 57 liter only)	414

04	Component series 7X	7X
----	---------------------	-----------

Pre-charge pressure ¹⁾

05	0 bar	0
----	-------	----------

Port size for hydraulic fluid

06		Nominal size (L)						
		1	4	10	20	35	57	
	G3/4 BSPP	✓	-	-	-	-	-	G05
	G1 1/4 BSPP	-	✓	-	-	-	-	G07
	G2 BSPP	-	-	✓	✓	✓	✓	G09
	1" NPT	✓	-	-	-	-	-	N05
	1-1/4" NPT	-	✓	-	-	-	-	N06
	2" NPT	-	-	✓	✓	✓	✓	N08
	1-1/2" SAE 4 bolt flange, code 62 (only 5000/6000 PSI)	-	-	✓	✓	✓	✓	S07
	2" SAE 4 bolt flange, code 61 (only 3000 PSI)	-	-	✓	✓	✓	✓	S09
	1-5/8"-12UN (#20 SAE)	-	✓	-	-	-	-	U08
	1-7/8"-12UN (#24 SAE)	-	-	✓	✓	✓	✓	U09
	1-5/16"-12UN (#16 SAE)	✓	-	-	-	-	-	U14

Type of mounting (fluid port design)

07	Bottom repairable threaded connection	G
	Top repairable threaded connection	GT
	Bottom repairable threaded connection, high flow	HG
	Bottom repairable flanged connection	F
	Top repairable flanged connection	FT
	Bottom repairable flanged connection, high flow	HF

Gas valve connection

08	Rexroth gas valve version 2 (ISO 4570, type 8V1)	2
----	--	----------

Ordering code (continued)

01	02	03	04	05	06	07	08	09	10	11	12	13				
HAB		-	-	7X	/	0		F	-	2		1		1	-	

Bladder material

09	Nitrile (Buna)	N
	Hydrin - Eco	E
	Fluoro-Elastomer (Viton®) Note: Viton® is a trademark of DuPont	F
	Butyl	I
	Cold weather nitrile	T

Tank material

10	Steel	1
----	-------	----------

Inside tank material

11	Steel	1
	Phenolic coating	3

Inside fluid port surface

12	Plain steel	1
----	-------------	----------

Certification (acceptance)

13	ASME certification	ASME
	CRN ²⁾ (Canadian Registration No.) certification	CRN

Order example:

HAB10-207-7X/OS09G-2N111-ASME

¹⁾ Default supply is a ~25 psi or less pre-charge to keep bladder inflated during shipment or storage. Customer specific pre-charges are possible, please consult factory.

²⁾ Not available on all configurations

Preferred Models HAB-7X

Model	Part number	Program
HAB1-207-7X/0N05G-2N111-ASME	R978059591	Standard
HAB1-207-7X/0U14G-2N111-ASME	R978059592	GoTo
HAB4-207-7X/0N06G-2N111-ASME	R978059593	Standard
HAB4-207-7X/0U08G-2N111-ASME	R978059594	GoTo
HAB4-207-7X/0U08G-2N111-CRN	R978059656	GoTo
HAB10-207-7X/0N08G-2N111-ASME	R978059595	Standard
HAB10-207-7X/0U09G-2N111-ASME	R978059597	GoTo
HAB10-207-7X/0S09F-2N111-ASME	R978059599	Standard
HAB10-207-7X/0U09G-2N111-CRN	R978059631	GoTo
HAB20-207-7X/0N08G-2N111-ASME	R978059604	Standard
HAB20-207-7X/0U09G-2N111-ASME	R978059605	GoTo
HAB20-207-7X/0S09F-2N111-ASME	R978059607	Standard
HAB20-207-7X/0U09G-2N111-CRN	R978059632	GoTo
HAB35-207-7X/0U09G-2N111-ASME	R978059610	GoTo
HAB35-207-7X/0S09F-2N111-ASME	R978059612	Standard
HAB35-207-7X/0U09G-2N111-CRN	R978059633	GoTo
HAB57-207-7X/0U09G-2N111-ASME	R978059616	GoTo
HAB57-207-7X/0S09F-2N111-ASME	R978059618	Standard
HAB57-207-7X/0U09G-2N111-CRN	R978059630	GoTo

Function, sectional drawing

Standard ASME models

Fluids are hardly compressible, whereas gases feature high compressibility. The operating principle of all gas-loaded hydraulic accumulators is based on this difference. Hydraulic accumulators basically consist of a fluid and a gas section with a gas-tight separating element. The fluid section is connected to the hydraulic circuit.

When a certain amount of pressurized gas is pressurized to a higher fluid pressure, the gas volume decreases as the fluid pressure rises.

When the fluid pressure falls, the fluid is pressed back into the hydraulic system through expansion of the gas until the pressure is again balanced.

Bladder-type accumulator

Bladder-type accumulators consist of a seamless cylindrical pressure vessel (1) made of high-tensile steel.

The accumulator is subdivided into a gas and a fluid side by an elastic bladder (2) mounted in the interior of the vessel.

The bladder is charged with nitrogen to the specified gas charge pressure p_0 by means of gas valve (4).

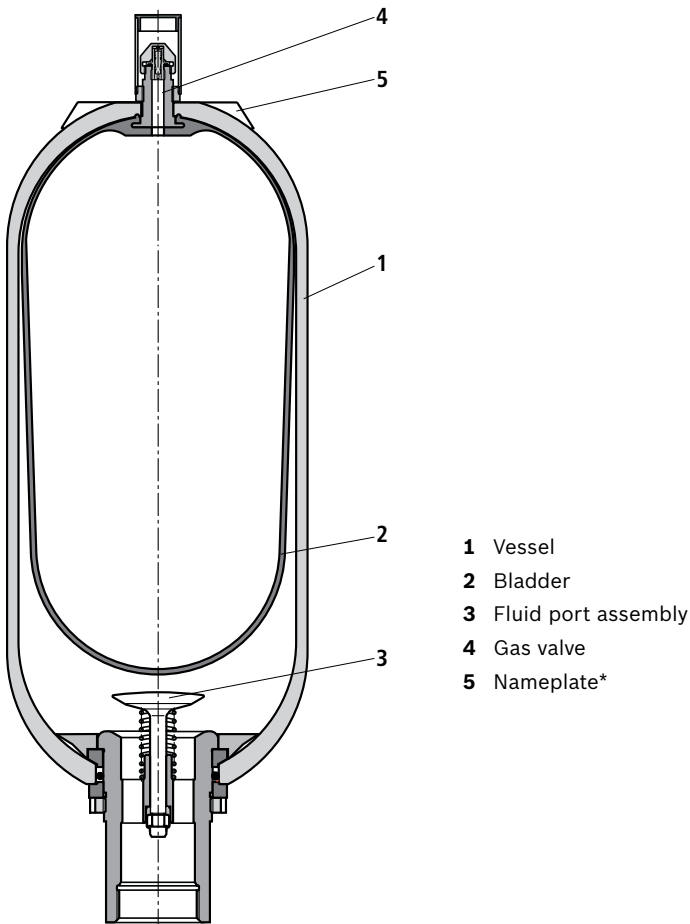

When the fluid is pressed into the accumulator, the gas in the bladder is compressed and hence the pressure increases. The gas volume reduces and on the fluid side, the fluid can flow into the accumulator. As soon as the pressure on the fluid side falls below the gas pressure, the accumulator is emptied.

Fluid port assembly (3) is provided in the oil port of the bladder-type accumulator and closes when the pressure on the gas side is higher than on the fluid side. This prevents draining of the bladder into the oil channel and thus the bladder from being destroyed.

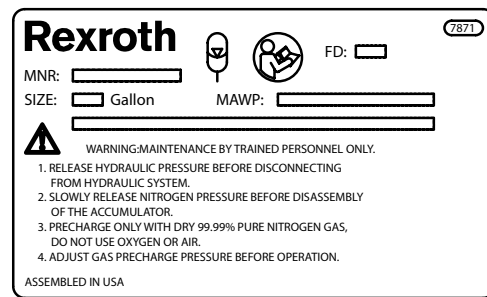

Information printed at time of manufacture:

- Material number (MNR)
- Size
- Date Code (FD)
- Maximum Allowable Working Pressure (MAWP)
- Model Code

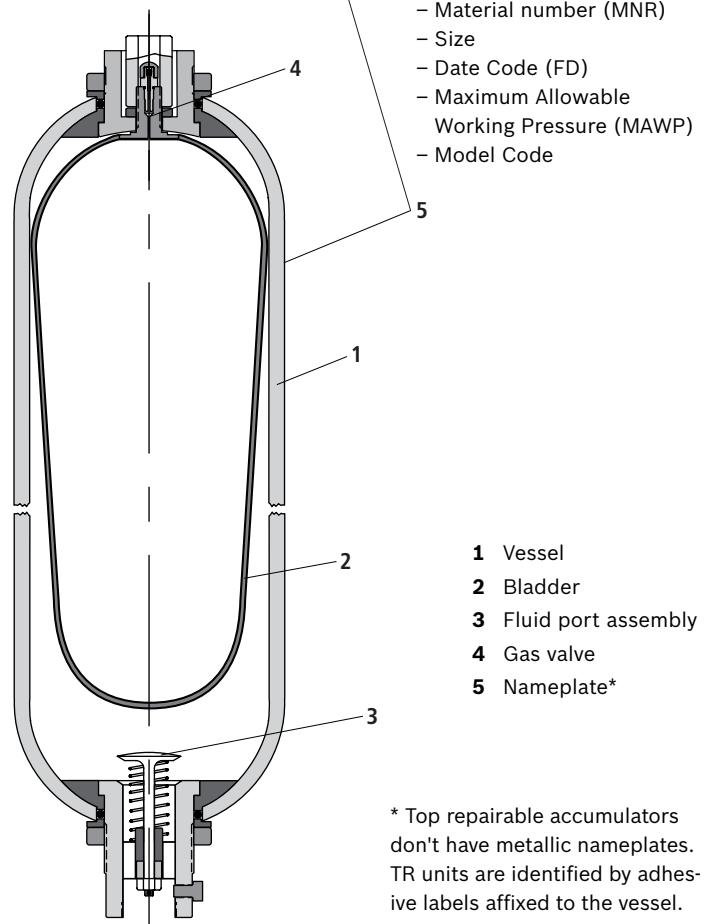

* Top repairable accumulators don't have metallic nameplates. TR units are identified by adhesive labels affixed to the vessel.

When the minimum operating pressure is reached, a small oil volume is to be maintained between the bladder and the fluid volume (approx. 10 % of the nominal capacity of the hydraulic accumulator), in order that the bladder does not hit the valve during every expansion process.

An example accumulator nameplate is shown in the following figure:

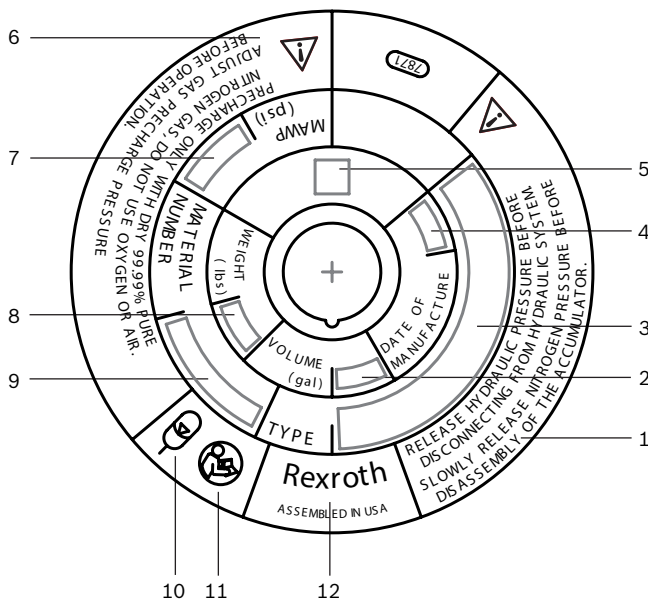

- 1 Warning 1
- 2 Volume
- 3 Type code
- 4 Date of production (month/year)
- 5 QR code
- 6 Warning 2
- 7 Maximum allowable working pressure (MAWP)
- 8 Weight
- 9 Material number
- 10 Symbol for bladder-type accumulator volume
- 11 Reference to operating instructions
- 12 Rexroth company identifier

Symbol

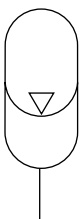

Application, mode of operation

Applications

Hydro-pneumatic accumulators can be used for the following functions:

- Store power for intermittent duty cycles thus economizing pump drive power.
- Provide energy or standby power
- Compensate for leakage loss
- Suspension in vehicles
- Dampen pulsations and shocks of a periodic nature

Mode of operation

Hydraulic accumulators are hydrostatic units, which can store a certain amount of energy and make it available to the hydraulic system when required.

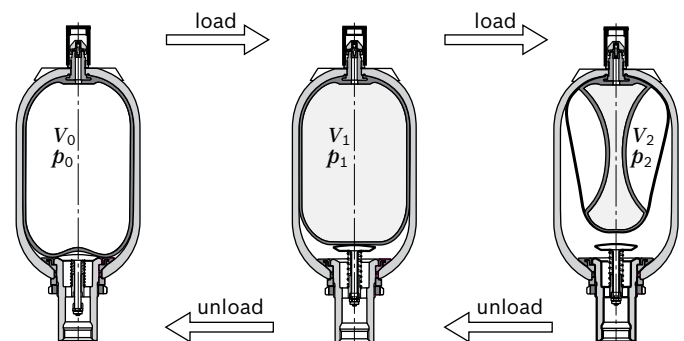

Technical data

(For applications outside these parameters, please consult us!)

General	
Weight	See tables beginning on page 10
Design	Bladder-type accumulator
Type of mounting	With clamping collars and console
Line connection	Screw-in thread or flange connections

Hydraulic										
Bottom repairable, 3000/4000 PSI	Nominal volume	V_{nom}	GAL	1 QT	1 G	2.5 G	5 G	10 G	15 G	
	Effective gas volume	V_{eff}	l	1.0	3.4	9.3	18.8	35.3	53.7	
	Maximum operating pressure	p_{max}	PSI	4000	4000	4000	4000	4000	4000	
Bottom repairable, 5000/6000 PSI	Nominal volume	V_{nom}	GAL			2.5 G	5 G	10 G	15 G	
	Effective gas volume	V_{eff}	l			9.3	18.8	35.3	53.7	
	Maximum operating pressure	p_{max}	PSI			6000	6000	6000	6000	
Top repairable, 3000/4000 PSI	Nominal volume	V_{nom}	GAL			2.5 G	5 G	10 G	15 G	
	Effective gas volume	V_{eff}	l			9.3	18.8	35.3	53.7	
	Maximum operating pressure	p_{max}	PSI			4000	4000	4000	4000	
Top repairable, 5000/6000 PSI	Nominal volume	V_{nom}	GAL			2.5 G	5 G	10 G	15 G	
	Effective gas volume	V_{eff}	l			9.3	18.8	35.3	53.7	
	Maximum operating pressure	p_{max}	PSI			6000	6000	6000	6000	
Hydraulic fluid				Mineral oils to DIN 51524, HFC to ISO 12922, other fluids compatible with bladder compounds listed.						
Operating temperature range ¹⁾		Nitrile, Buna-n (NBR) Hydrin epichlorohydrin (ECO) Viton® fluoroelastomer (FKM) Butyl (IIR) Cold weather nitrile (HNBR)		°F	5 ... 200 -26 ... 200 -4 ... 200 5 ... 200 -50 ... 158					
Flow output (Standard SAE fluid port, max flow rate dependant on fluid viscosity and accumulator orientation)		Nominal volume		GAL	1 QT	1 G	2.5 G	5 G	10 G	15 G
		Maximum flow rate		GPM	79	119	238	238	238	238

Mounting position

Bosch Rexroth bladder accumulators in the 1Qt to 15 gallon design can be installed in either vertical or non-vertical orientations. When mounted vertically or at an angle, the fluid port must be at the bottom of the installation. Installation recommendations change based on application types as follows:

Energy storage	Vertical installation is preferred. Non-vertical installations can result in performance reduction.
Pulsation dampening	Any installation from vertical to horizontal.
Leakage compensation	Any installation from vertical to horizontal.
Volume and pressure	Any installation from vertical to horizontal.

Please consult factory if further review of your specific application type is needed.

Pneumatic	
Charging gas	Nitrogen gas with typical purity 99.99%
Pre-charge ratio limitation	Maximum ratio of system pressure to pre-charge pressure, 4:1

¹⁾ This limit is based on shell strength calculations and not on bladder material.

Note: Viton® is a trademark of DuPont

Sizing calculations

The majority of applications use accumulators to store energy for intermittent duty cycles or to provide a source of emergency power. In either case, the problem is determining the optimum size and precharge of the accumulator.

Accumulator sizing is based on the gas charge. The change in gas volume and pressure determines the amount of liquid that can be added or withdrawn. However, unlike mechanical springs, compressing a gas tends to heat it, raising the pressure above what would be expected from compression alone. Expanding a gas tends to cool it, reducing the pressure below that caused by expansion alone. Either of these effects can substantially affect accumulator sizing. Expansion (or compression) of a gas resulting in a change of gas temperature produces adiabatic expansion. When an accumulator is discharged rapidly, there is not enough time for sufficient heat transfer through the accumulator walls and adiabatic expansion occurs.

If the expansion (or compression) occurs slowly, there is sufficient time for heat to be added (or subtracted) by the accumulator wall to maintain a constant gas temperature and isothermal expansion occurs. The median of these two states of expansion can be partially "adiabatic".

When carrying out the calculations for an accumulator, the following pressures are of primary importance:

- p_0 = Gas pre-charge pressure at room temperature and with liquid chamber drained
- p_1 = Minimum operating pressure
- p_2 = Maximum operating pressure

The following relationships apply: the gas pre-charge pressure is to be slightly lower than the minimum hydraulic pressure so that the bladder does not continually contact the oil valve (wear).

$$p_0 \approx 0.9 \cdot p_1 \quad (1)$$

The maximum hydraulic pressure is not to exceed 4 times the pre-charge pressure; otherwise, the elasticity of the bladder or diaphragm will be adversely affected. Also, excessive changes in pressure result in considerable heating of the gas. Reducing the pressure differential between p_1 and p_2 increases bladder service life. On the other hand, it must be taken into account that a lower pressure differential also reduces the utilization of available storage capacity.

Bladder-type accumulators

$$p_2 \leq 4 \cdot p_0 \quad (2)$$

Oil volumes

The gas volumes $V_0 \dots V_2$ correspond to the pressures $p_0 \dots p_2$. Here, V_0 is the rated volume of the accumulator. The available oil volume ΔV corresponds to the difference between the oil volume V_1 and V_2 .

$$\Delta V = V_2 - V_1 \quad (3)$$

The variable gas volume for a given pressure difference is determined according to the following equations:

- a) For isothermal change of state of gases, the following equation applies:

$$p_0 \cdot V_0 = p_1 \cdot V_1 = p_2 \cdot V_2 \quad (4.1)$$

The isothermal equation is used when the change in the gas volume takes place so slowly that there is sufficient time for the complete exchange of heat to take place between the nitrogen and its surroundings. The result is a constant temperature.

- b) For adiabatic change of state of gases, the following formula applies:

$$p_0 \cdot V_{n0} = p_1 \cdot V_{n1} = p_2 \cdot V_{n2} \quad (4.2)$$

n = relationship of the specific heats of the gas (adiabatic component); $n = 1.4$ for nitrogen. The equation for adiabatic change of state is used when the change in the gas volume takes place so rapidly that the temperature of the nitrogen also changes.

In most cases the changes of state tend to follow the adiabatic rather than the isothermal laws. It is often the case that the charge takes place isothermally and the discharge adiabatically. Considering the equations (1) and (2), ΔV is about 50 to 70% of the rated accumulator volume. The following formula can act as a guideline for sizing accumulators:

$$V_0 = 1.5 \dots 3x \Delta V \quad (5)$$

Sizing calculations

Calculation diagrams

The formula (4.1) and (4.2) are converted into diagrams on page 9 for graphic calculation purposes. Depending on the type of problem, the available oil volume, the accumulator size or the pressures can be determined.

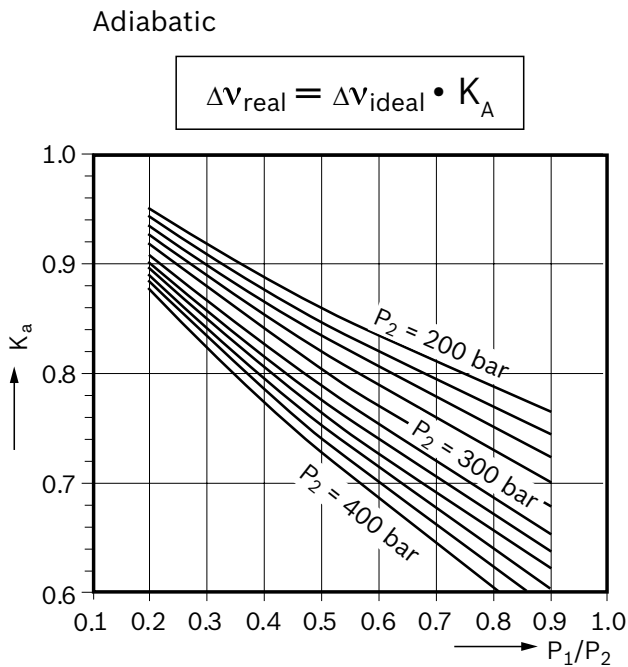

Using the diagrams

With the pre-charge pressure (p_0) and the minimum and maximum system pressures (p_1 and p_2) known, the available volume can be determined from the charts. Vertical lines are drawn from p_1 and p_2 to intersect the appropriate pre-charge curve. From the points of intersection, horizontal lines are then drawn to the left axis. Here V_1 and V_2 can be determined for the various sizes of accumulators. The difference between these values is the available volume. Similarly, pressures can be determined if the volume is known.

Correction factors K_i and K_a

The formula (4.1) and (4.2) apply to ideal gases only. In practice, at pressures above 200 bar (2900 PSI), the behavior of real gases deviates markedly from that of the ideal gases. This makes it necessary to use correction factors. These are to be taken from the following diagrams. The correction factors, with which the ideal discharge volume ΔV must be multiplied, are in the range of 0.6 ... 1.

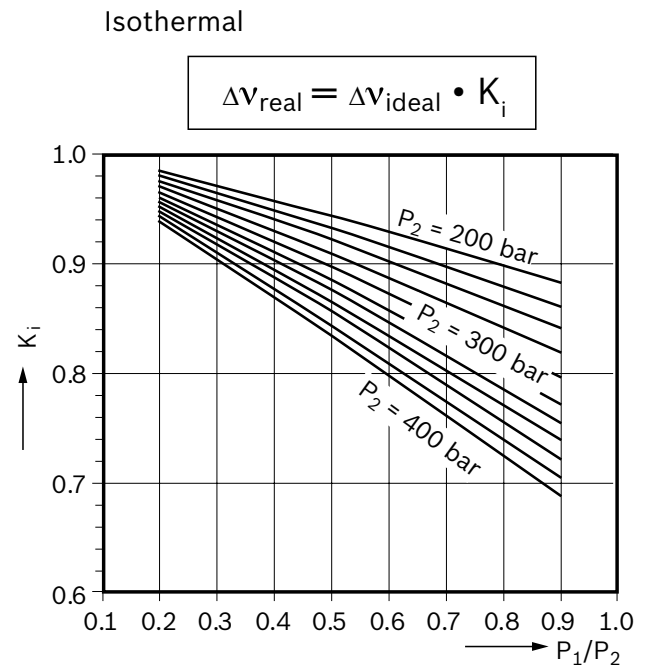

How to use the calculation diagrams

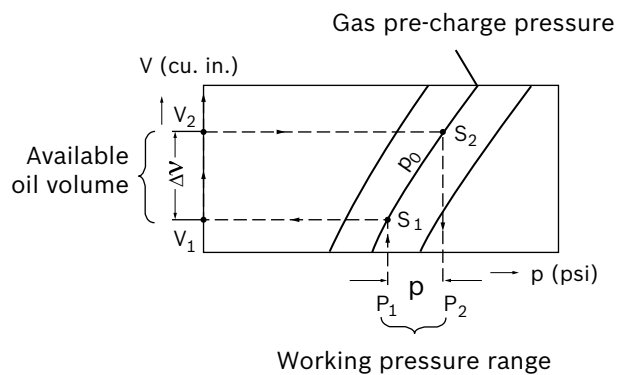

Sizing calculations

Pressure-Volume Curve, Adiabatic Relationship; Bladder Type Accumulator

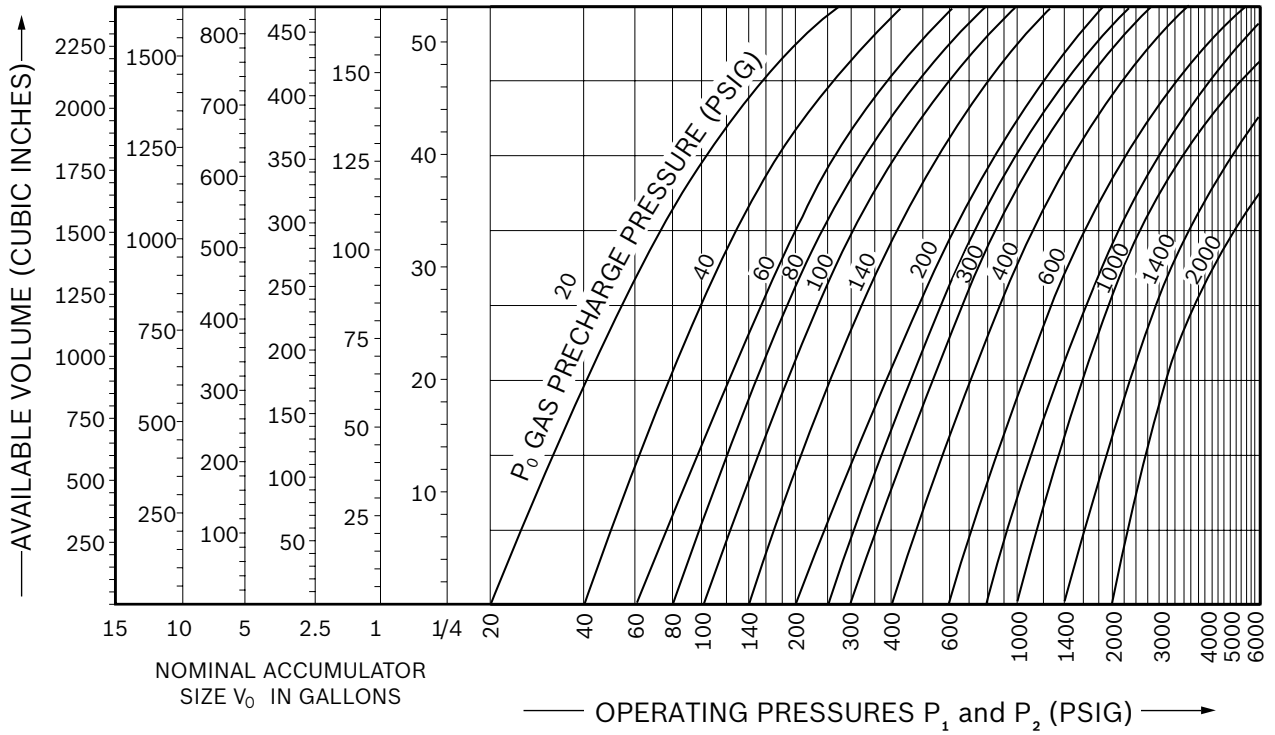

Pressure-Volume Curve, Isothermal Relationship; Bladder Type Accumulator

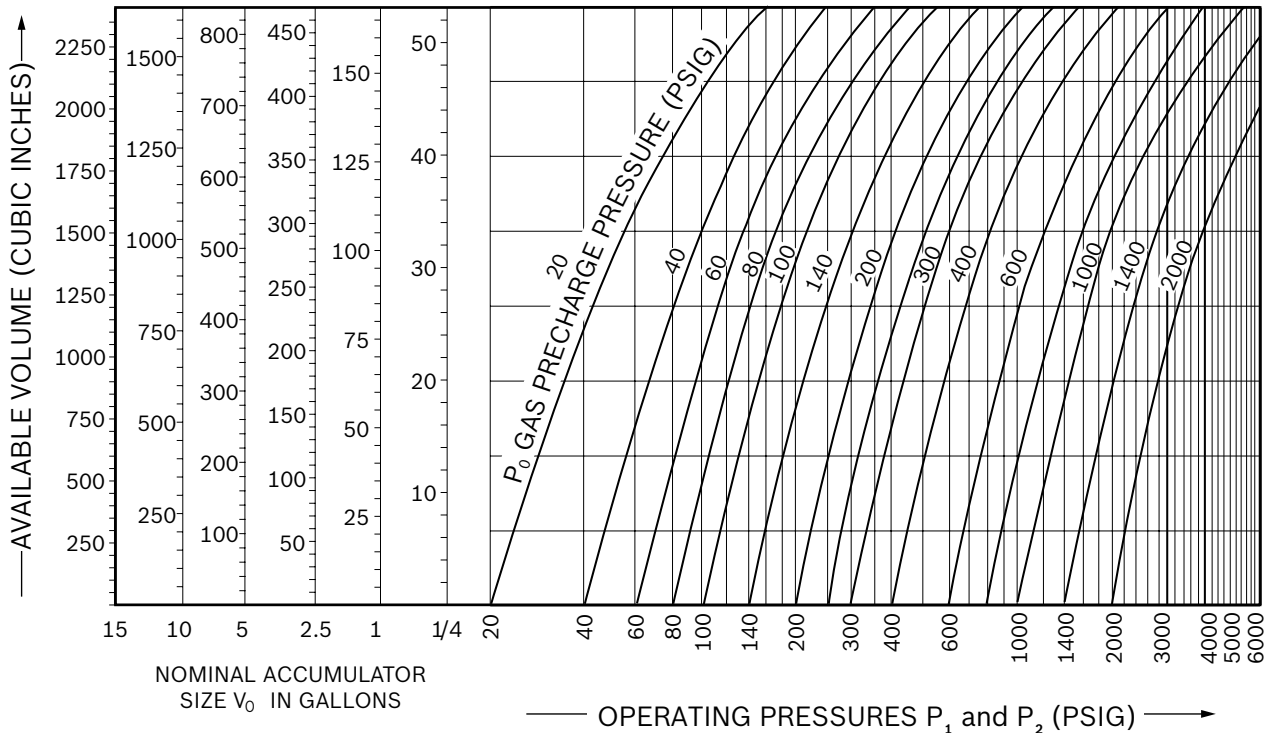

Dimensions, 1 quart and 1 gallon accumulators, HAB-7X ASME
 [dimensions in inches (mm)]

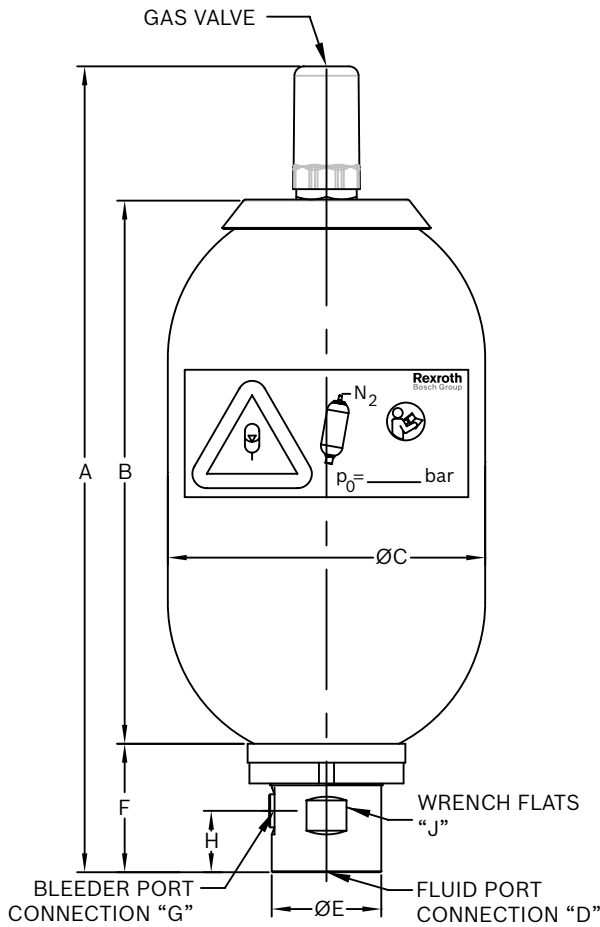

Fluid Port and Bleeder Port Connections with Thread Types

1 Quart Fluid Ports

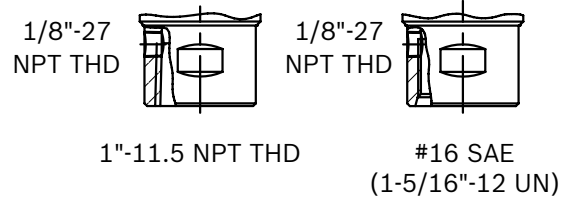

1 Gallon Fluid Ports

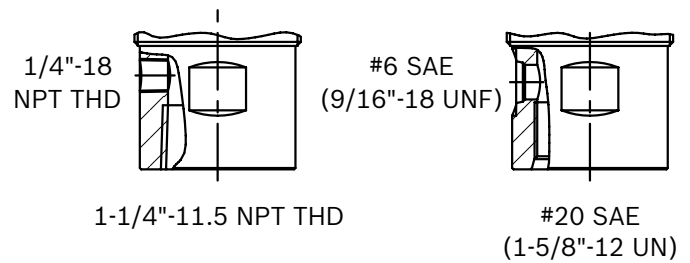

Notes:

1. All dimensions are nominal
2. Tolerance on overall length "A" is $\pm 1/2"$ (± 12.7 mm)

Nominal size	Max. allowable working pressure psi (bar)	Overall length A in. (mm)	Shell		Fluid port			Bleeder port		Wrench flats J in. (mm)	Approx. weight lbs. (kg)
			Length B in. (mm)	\varnothing C in. (mm)	Conn. D	\varnothing E in. (mm)	Length F in. (mm)	Conn. G	Location H in. (mm)		
1 Quart (1 liter)	3000 (207) or 4000 (276)	12.17 (309)	7.50 (190.5)	4.49 (114)	1" NPT	1.65 (42)	1.85 (47)	1/8" NPT	0.91 (23)	1.50 (38)	15.4 (7)
					#16 SAE						
1 Gallon (4 liter)	3000 (207) or 4000 (276)	16.81 (427)	11.26 (286)	6.61 (168)	1-1/4" NPT	2.28 (58)	2.68 (68)	1/4" NPT	1.38 (35)	2.13 (54)	35.3 (16)
					#16 SAE			#6 SAE	1.28 (33.5)		

Dimensions, 2.5 to 15 gallon accumulators, 3000/4000 psi, HAB-7X ASME, bottom repairable

[dimensions in inches (mm)]

Fluid Port and Bleeder Port Connections with Thread Types

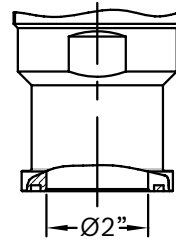
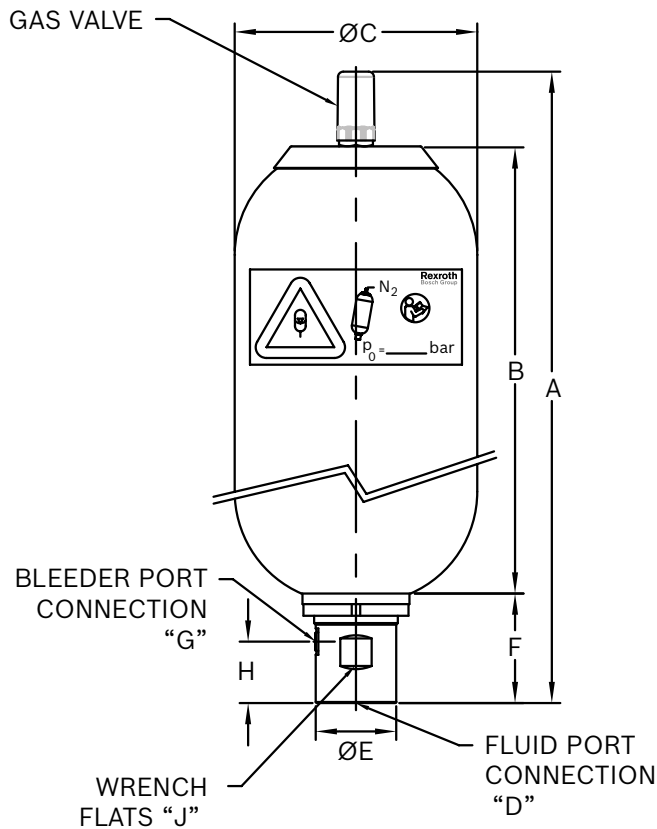
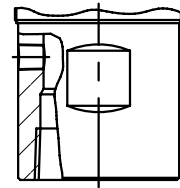
1/4"-18
NPT THD

2" SAE SPLIT FLANGE
CODE 61
NOT PERMISSIBLE
FOR 4,000 PSI

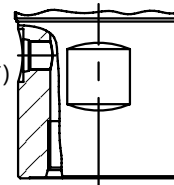
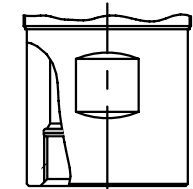
#6 SAE
(9/16"-18 UNF)#24 SAE
(1-7/8"-12 UN THD)

Notes:

1. All dimensions are nominal
2. Tolerance on overall length "A" is $\pm 1/2"$ (± 12.7 mm)

Nominal size	Max. allowable working pressure psi (bar)	Overall length A in. (mm)	Shell		Fluid port			Bleeder plug		Wrench flats J in. (mm)	Approx. weight lbs. (kg)
			Length B in. (mm)	ØC in. (mm)	Conn. D	ØE in. (mm)	Length F in. (mm)	Conn. G	Loc. H in. (mm)		
2.5 Gallon (10 liter)	3000 (207)	22.6 (574)	15.63 (397)	9.01 (229)	2" SAE Flange	2.81 (71.4)	4.15 (105.5)	-		2.76 (70)	83.8 (38)
	3000 (207) or 4000 (276)	2"-11.5 NPT			3.00 (76)	4.07 (103.5)	1/4"-18 NPT	2.28 (58)			
		#24 SAE					#6 SAE				
		G2-ISO 228					-				
5 Gallon (20 liter)	3000 (207)	34.88 (886)	27.91 (709)	9.01 (229)	2" SAE Flange	2.81 (71.4)	4.15 (105.5)	-		2.76 (70)	134.5 (61)
	3000 (207) or 4000 (276)	2"-11.5 NPT			3.00 (76)	4.07 (103.5)	1/4"-18 NPT	2.28 (58)			
		#24 SAE					#6 SAE				
		G2-ISO 228					-				
10 Gallon (35 liter)	3000 (207)	55.98 (1422)	49.02 (1245)	9.01 (229)	2" SAE Flange	2.81 (71.4)	4.15 (105.5)	-		2.76 (70)	222.7 (101)
	3000 (207) or 4000 (276)	2"-11.5 NPT			3.00 (76)	4.07 (103.5)	1/4"-18 NPT	2.28 (58)			
		#24 SAE					#6 SAE				
		G2-ISO 228					-				
15 Gallon (57 liter)	3000 (207)	79.02 (2007)	72.05 (1830)	9.01 (229)	2" SAE Flange	2.81 (71.4)	4.15 (105.5)	-		2.76 (70)	321.9 (146)
	3000 (207) or 4000 (276)	2"-11.5 NPT			3.00 (76)	4.07 (103.5)	1/4"-18 NPT	2.28 (58)			
		#24 SAE					#6 SAE				
		G2-ISO 228					-				

Dimensions, 2.5 to 15 gallon accumulators, 3000/4000 psi, HAB-7X ASME, top repairable
 [dimensions in inches (mm)]

Fluid Port and Bleeder Port Connections with Thread Types

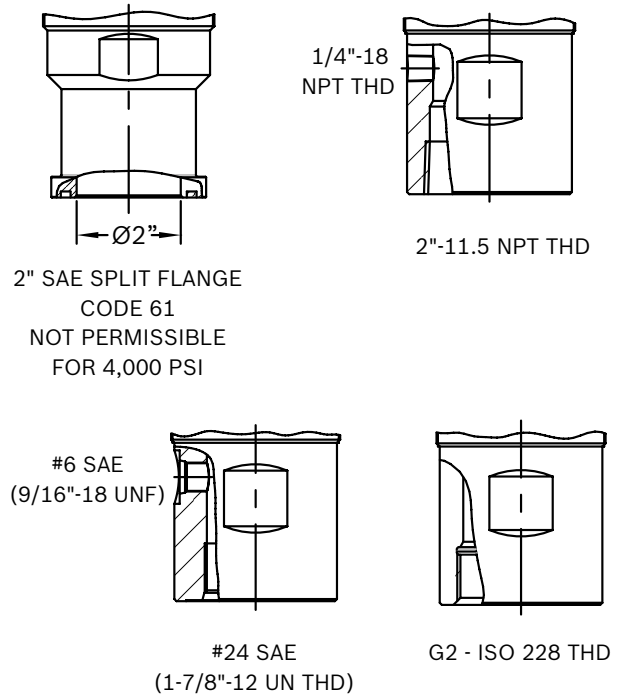
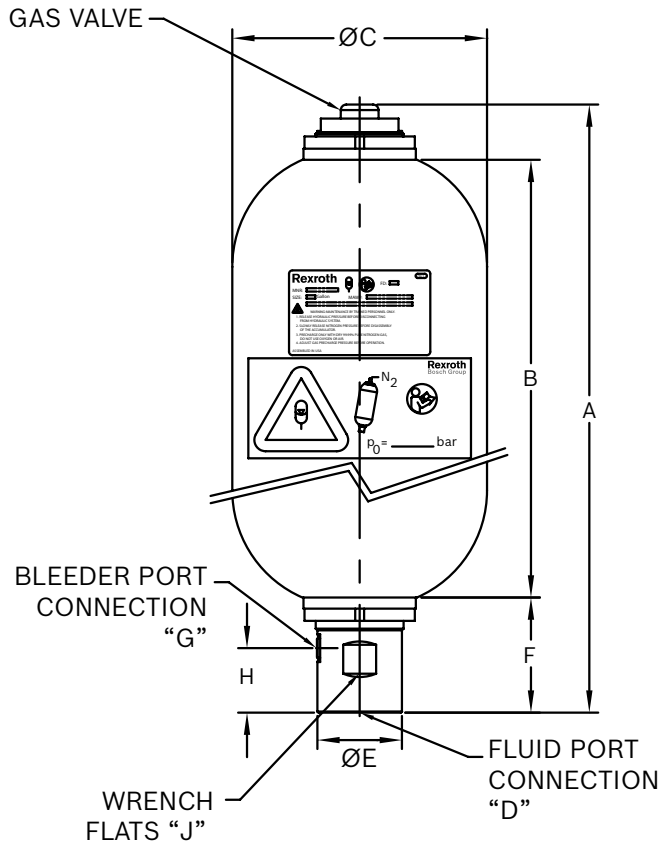

Notes:

1. All dimensions are nominal
2. Tolerance on overall length "A" is $\pm 1/2"$ (± 12.7 mm)

Nominal size	Max. allowable working pressure psi (bar)	Overall length A in. (mm)	Shell		Fluid port			Bleeder plug		Wrench flats J in. (mm)	Approx. weight lbs. (kg)
			Length B in. (mm)	ØC in. (mm)	Conn. D	ØE in. (mm)	Length F in. (mm)	Conn. G	Loc. H in. (mm)		
2.5 Gallon (10 liter)	3000 (207)	21.61 (549)	15.51 (394)	9.01 (229)	2" SAE Flange	2.81 (71.4)	4.15 (105.5)	-		2.76 (70)	88.2 (40)
	3000 (207) or 4000 (276)	2"-11.5 NPT			3.00 (76)	4.07 (103.5)	1/4"-18 NPT	2.28 (58)			
		#24 SAE					#6 SAE				
		G2-ISO 228					-				
5 Gallon (20 liter)	3000 (207)	33.62 (854)	27.52 (699)	9.01 (229)	2" SAE Flange	2.81 (71.4)	4.15 (105.5)	-		2.76 (70)	138.9 (63)
	3000 (207) or 4000 (276)	2"-11.5 NPT			3.00 (76)	4.07 (103.5)	1/4"-18 NPT	2.28 (58)			
		#24 SAE					#6 SAE				
		G2-ISO 228					-				
10 Gallon (35 liter)	3000 (207)	54.33 (1380)	48.23 (1225)	9.01 (229)	2" SAE Flange	2.81 (71.4)	4.15 (105.5)	-		2.76 (70)	224.9 (102)
	3000 (207) or 4000 (276)	2"-11.5 NPT			3.00 (76)	4.07 (103.5)	1/4"-18 NPT	2.28 (58)			
		#24 SAE					#6 SAE				
		G2-ISO 228					-				
15 Gallon (57 liter)	3000 (207)	78.07 (1983)	71.97 (1828)	9.01 (229)	2" SAE Flange	2.81 (71.4)	4.15 (105.5)	-		2.76 (70)	326.3 (148)
	3000 (207) or 4000 (276)	2"-11.5 NPT			3.00 (76)	4.07 (103.5)	1/4"-18 NPT	2.28 (58)			
		#24 SAE					#6 SAE				
		G2-ISO 228					-				

Dimensions, 2.5 to 15 gallon accumulators, 5000/6000 psi, HAB-7X ASME, bottom repairable

[dimensions in inches (mm)]

Fluid Port and Bleeder Port Connections with Thread Types

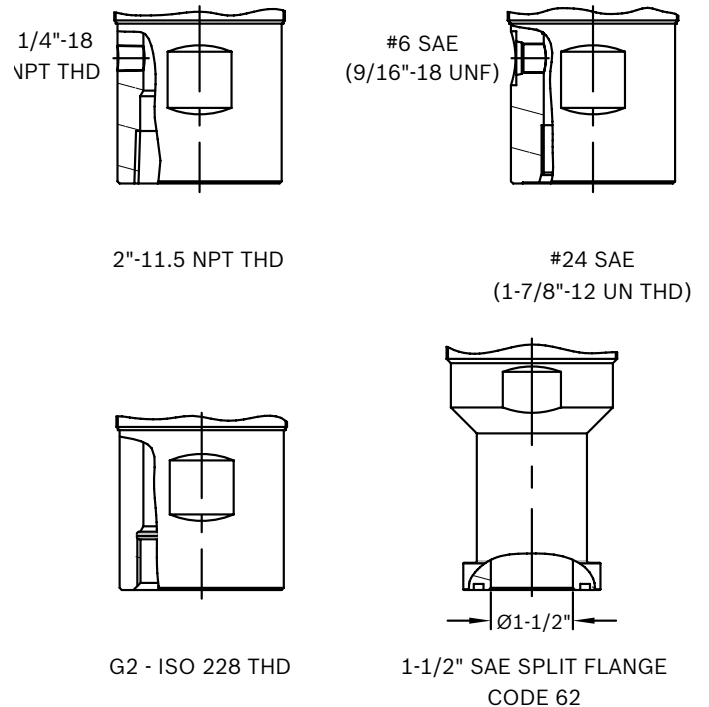
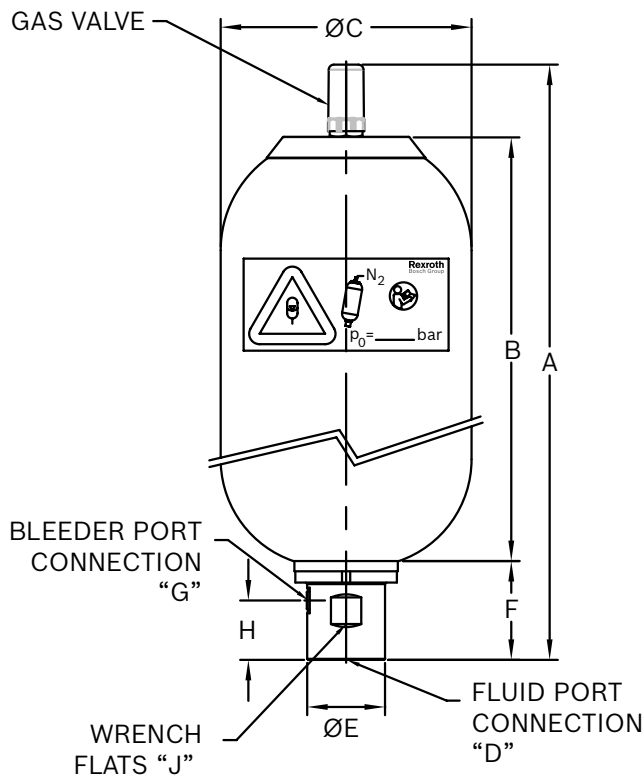

Notes:

1. All dimensions are nominal
2. Tolerance on overall length "A" is $\pm 1/2"$ (± 12.7 mm)

Nominal size	Max. allowable working pressure psi (bar)	Overall length A in. (mm)	Shell		Fluid port			Bleeder plug		Wrench flats J in. (mm)	Approx. weight lbs. (kg)
			Length B in. (mm)	ØC in. (mm)	Conn. D	ØE in. (mm)	Length F in. (mm)	Conn. G	Loc. H in. (mm)		
2.5 Gallon (10 liter)	5000 (345) or 6000 (414)	22.87 (581)	16.26 (413)	9.65 (245)	2"-11.5 NPT	3.00 (76)	3.80 (96.5)	1/4"-18 NPT	2.28 (58)	2.76 (70)	127.9 (58)
					#24 SAE			#6 SAE			
		24.06 (611)			G2-ISO 228	2.50 (63.5)	4.98 (126.5)	-			
					1-1/2" SAE Flange						
5 Gallon (20 liter)	5000 (345) or 6000 (414)	34.88 (886)	28.27 (718)	9.65 (245)	2"-11.5 NPT	3.00 (76)	3.80 (96.5)	1/4"-18 NPT	2.28 (58)	2.76 (70)	209.4 (95)
					#24 SAE			#6 SAE			
		36.06 (916)			G2-ISO 228	2.50 (63.5)	4.98 (126.5)	-			
					1-1/2" SAE Flange						
10 Gallon (35 liter)	5000 (345) or 6000 (414)	55.63 (1413)	49.02 (1245)	9.65 (245)	2"-11.5 NPT	3.00 (76)	3.80 (96.5)	1/4"-18 NPT	2.28 (58)	2.76 (70)	354.9 (161)
					#24 SAE			#6 SAE			
		56.81 (1443)			G2-ISO 228	2.50 (63.5)	4.98 (126.5)	-			
					1-1/2" SAE Flange						
15 Gallon (57 liter)	5000 (345) or 6000 (414)	78.62 (1997)	72.01 (1829)	9.65 (245)	2"-11.5 NPT	3.00 (76)	3.80 (96.5)	1/4"-18 NPT	2.28 (58)	2.76 (70)	515.9 (234)
					#24 SAE			#6 SAE			
		79.86 (2027)			G2-ISO 228	2.50 (63.5)	4.98 (126.5)	-			
					1-1/2" SAE Flange						

Dimensions, 2.5 to 15 gallon accumulators, 5000/6000 psi, HAB-7X ASME, top repairable
 [dimensions in inches (mm)]

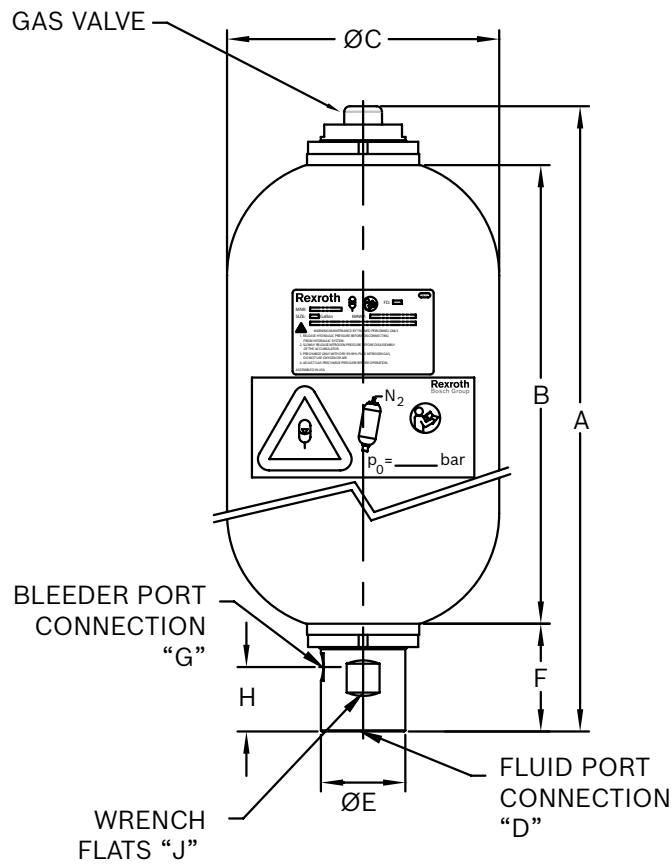

Fluid Port and Bleeder Port Connections with Thread Types

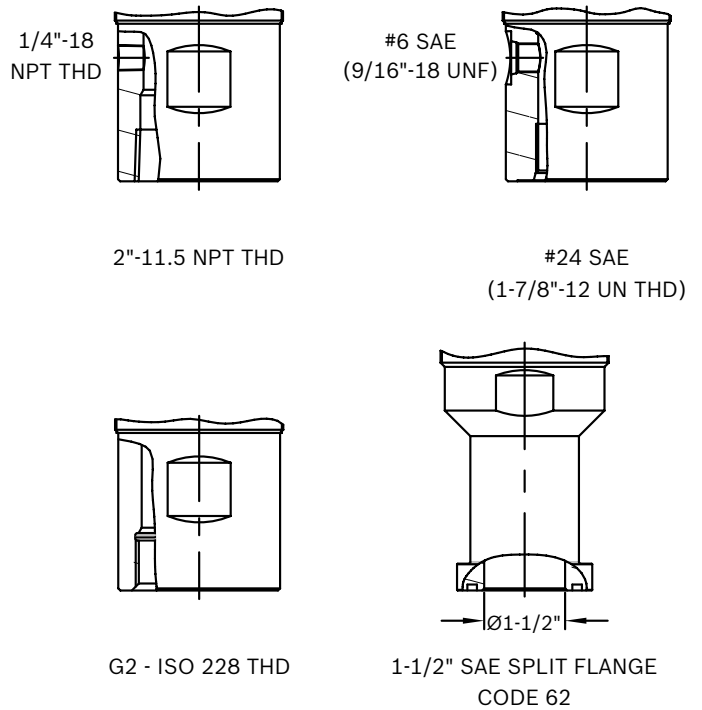

Notes:

1. All dimensions are nominal
2. Tolerance on overall length "A" is $\pm 1/2"$ (± 12.7 mm)

Nominal size	Max. allowable working pressure psi (bar)	Overall length A in. (mm)	Shell		Fluid port			Bleeder plug		Wrench flats J in. (mm)	Approx. weight lbs. (kg)
			Length B in. (mm)	ØC in. (mm)	Conn. D	ØE in. (mm)	Length F in. (mm)	Conn. G	Loc. H in. (mm)		
2.5 Gallon (10 liter)	5000 (345) or 6000 (414)	22.17 (563)	16.26 (413)	9.65 (245)	2"-11.5 NPT	3.00 (76)	3.82 (97)	1/4"-18 NPT	2.28 (58)	2.76 (70)	132.3 (60)
					#24 SAE			#6 SAE			
		G2-ISO 228			-						
		1-1/2" SAE Flange			2.50 (63.5)	5.00 (127)	-				
5 Gallon (20 liter)	5000 (345) or 6000 (414)	34.17 (868)	28.27 (718)	9.65 (245)	2"-11.5 NPT	3.00 (76)	3.82 (97)	1/4"-18 NPT	2.28 (58)	2.76 (70)	207.3 (94)
					#24 SAE			#6 SAE			
		G2-ISO 228			-						
		1-1/2" SAE Flange			2.50 (63.5)	5.00 (127)	-				
10 Gallon (35 liter)	5000 (345) or 6000 (414)	54.92 (1395)	49.02 (1245)	9.65 (245)	2"-11.5 NPT	3.00 (76)	3.82 (97)	1/4"-18 NPT	2.28 (58)	2.76 (70)	332.9 (151)
					#24 SAE			#6 SAE			
		G2-ISO 228			-						
		1-1/2" SAE Flange			2.50 (63.5)	5.00 (127)	-				
15 Gallon (57 liter)	5000 (345) or 6000 (414)	77.91 (1979)	72.01 (1829)	9.65 (245)	2"-11.5 NPT	3.00 (76)	3.82 (97)	1/4"-18 NPT	2.28 (58)	2.76 (70)	474 (215)
					#24 SAE			#6 SAE			
		G2-ISO 228			-						
		1-1/2" SAE Flange			2.50 (63.5)	5.00 (127)	-				

Accessories for HAB accumulators with BSPP fluid ports

Adapters and flanges (rated pressure 350 bar)

The M33 threaded adapters on this page are designed to be used with ABZSS model safety blocks ³⁾ and are not compatible with VAW model safety blocks.

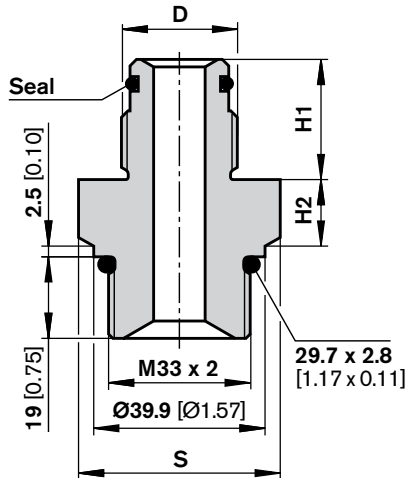

Figure A

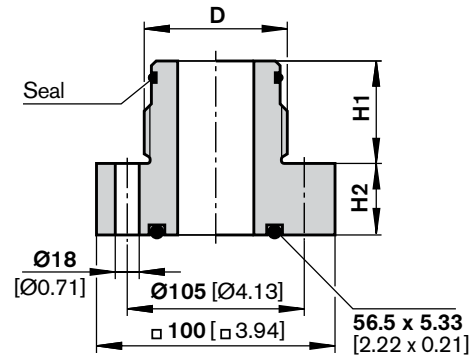

Figure B

Accumulator safety block ³⁾	Accumulator size	Accumulator adapter	Figure	S	H1	H2	D	Seal
ABZSS 10 ABZSS 20	1 Quart (1 Liter)	S10	A	SW41 (1.61" A/F)	28 (1.10)	15.5 (0.61)	G3/4 A	18 x 2.5 (0.71 x 0.10)
	1 Gallon (4 Liter)	S12		SW46 (1.81" A/F)	37 (1.46)	16.5 (0.65)	G1 1/4 A	30 x 3 (1.18x0.12)
	2.5 Gallon (10 Liter)	S13		SW65 (2.55" A/F)	43 (1.69)	20.5 (0.81)	G2 A	48 x 3 (1.89 x 0.12)
	5 Gallon (20 Liter)							
	10 Gallon (35 Liter)							
	15 Gallon (57 Liter)							
ABZSS 30	1 Gallon (4 Liter)	S307	B	-	37 (1.46)	30 (1.18)	G1 1/4 A	30 x 3 (1.18x0.12)
	2.5 Gallon (10 Liter)	S309		-	43 (1.69)	30 (1.18)	G2 A	48 x 3 (1.89 x 0.12)
	5 Gallon (20 Liter)							
	10 Gallon (35 Liter)							
	15 Gallon (57 Liter)							

Ordering code

Short code	Accumulator adapter	Part number FKM	Accumulator adapter	Part number NBR ²⁾
S10	S10V/G3/4-M33 x 2	R900545254	S10 M/G3/4-M33 x 2	R900862699
S12	S12V/G1 1/4-M33 x 2	R900545255	S12 M/G1 1/4-M33 x 2	R900862700
S13	S13V/G2-M33 x 2	R900545256	S13 M/G2-M33 x 2	R900862701
S307	S307V/G1 1/4-DN32 ¹⁾	R900085303	S307 M/G1 1/4-DN32 ¹⁾	R900067050
S309	S309V/G2-DN32 ¹⁾	R900545858	S309M/G2-DN32 ¹⁾	R900862702

¹⁾ 4 off ISO 4762-M16 x 45-10.9 hexagon socket head cap screws are included in the scope of supply.

²⁾ Special version

³⁾ Further details on the Rexroth ABZSS safety block can be found in datasheet RE 50131. Additional adapter options for ABZSS 08 size safety blocks are possible, consult factory.

Accessories for HAB accumulators with SAE fluid ports

The M33 threaded adapters on this page are designed to be used with ABZSS model safety blocks ³⁾ and are not compatible with VAW model safety blocks.

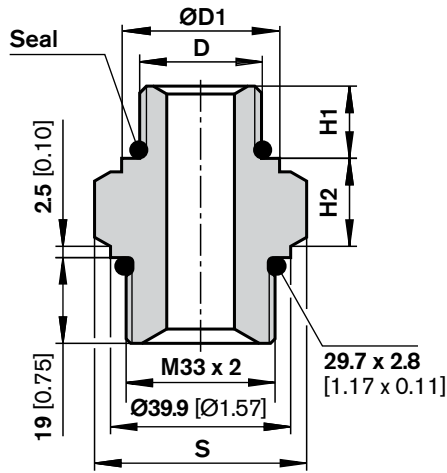

Figure A

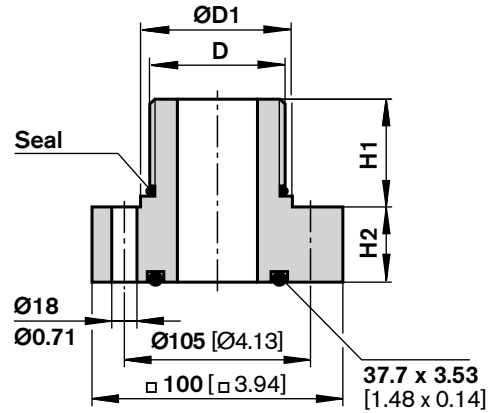

Figure B

Accumulator safety block ³⁾	Accumulator size	Accum. adapter	Fig.	S	H1	H2	D	ØD1	Seal
ABZSS 10 ABZSS 20	1 Quart (1 Liter)	S60	A	SW41 (1.61" A/F)	15.2 (0.60)	20.3 (0.80)	1 1/16-12UN-2A	32 (1.26)	23.0 x 3.0 (0.91 x 0.12)
	1 Gallon (4 Liter)	S62					1 5/8-12UN-2A	48 (1.89)	38.0 x 3.0 (1.50 x 0.12)
	2.5 Gallon (10 Liter)	S63		SW65 (2.55" A/F)			1 7/8-12UN-2A	54 (2.13)	44.0 x 3.0 (1.73 x 0.12)
	5 Gallon (20 Liter)								
	10 Gallon (35 Liter)								
	15 Gallon (57 Liter)								
ABZSS 30	1 Gallon (4 Liter)	S620	B	-	15.2 (0.60)	33.8 (1.33)	1 5/8-12UN-2A	48 (1.89)	38.0 x 3.0 (1.50 x 0.12)
	2.5 Gallon (10 Liter)	S630					1 7/8-12UN-2A	54 (2.13)	44.0 x 3.0 (1.73 x 0.12)
	5 Gallon (20 Liter)								
	10 Gallon (35 Liter)								
	15 Gallon (57 Liter)								

Ordering code

Short code	Accumulator adapter	Part number FKM	Accumulator adapter	Part number NBR ²⁾
S60	S60V/1 1/16-12UN-M33 x 2	R900618788	S60M/ 1 1/16-12UN-M33 x 2	R900618799
S62	S62V/1 5/8-12UN-M33 x 2	R900618800	S60M/ 1 5/8-12UN-M33 x 2	R900618801
S63	S63V/1 7/8-12UN-M33 x 2	R900618803	S63M/ 1 7/8-12UN-M33 x 2	R900618804
S620	S620V/1 5/8-12UN-DN32 ¹⁾	R900618813	S620M/ 1 5/8-12UN-DN32 ¹⁾	R900618814
S630	S630V/1 7/8-12UN-DN32 ¹⁾	R900618817	S630M/ 1 7/8-12UN-DN32 ¹⁾	R900618815

¹⁾ 4 off ISO 4762-M16 x 45-10.9 hexagon socket head cap screws are included in the scope of supply.

²⁾ Special version

³⁾ Further details on the Rexroth ABZSS safety block can be found in datasheet RE 50131.

Clamps and brackets

Features:

- Allows secure yet easy installation of accumulator in vertical position.
- Clamps can be bolted or welded to support structure.

Rubber cushioning on straps help prevent noises from being transmitted through metal to metal contact.
 Mounting bracket available for support of vertical mounting of large sizes.

HAB-7X 3000/4000 PSI ASME/CRN

Important note: Mounting bracket and clamps shown on page 17 and 18 are to be used with the following units:

- 207 bar (3000 PSI) ASME/CRN units
- 275 bar (4000 PSI) ASME/CRN units

Please refer to page 19 for 345 bar (5000 PSI) and 414 bar (6000 PSI) ASME/CRN mounting bracket and clamp.

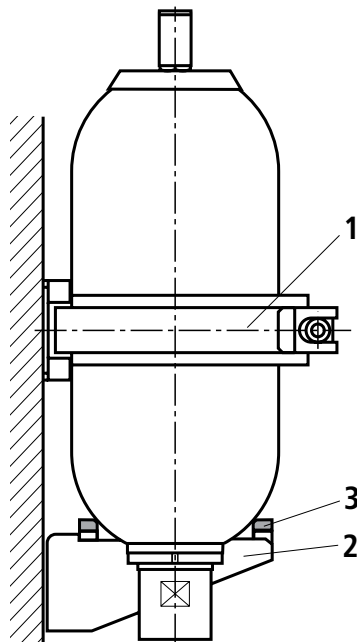

- 1 Clamp
- 2 Mounting bracket
- 3 Rubber back-up ring

Accessory	Part number	Accumulator size					
		1 quart	1 gal	2.5 gal	5 gal	10 gal	15 gal
Clamp 110-120	1531316021	1					
Clamp 160-170	1531316022		2				
Clamp 224-230	1531316005			1	1	2	2
Mounting bracket	1531334008			1	1	1	1
Rubber back-up ring	1530221042			1	1	1	1

Mounting bracket and rubber back-up ring

(only used on 2.5 gallon and larger units, 3000/4000 PSI ASME/CRN)

Mounting bracket, Part no. 1531334008

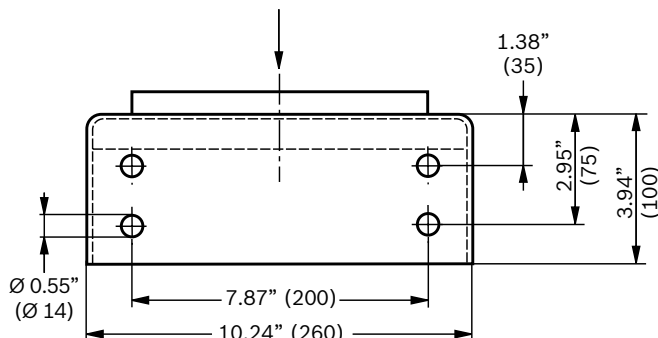

Rubber back-up ring, Part no. 1530221042

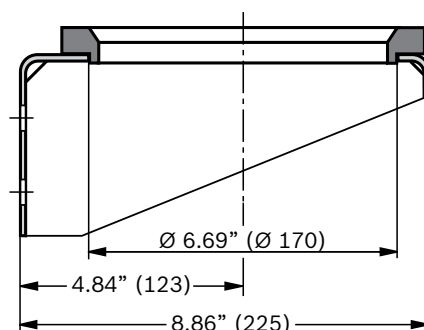

HAB-7X 3000/4000 PSI ASME/CRN

Mounting clamps

Type F1

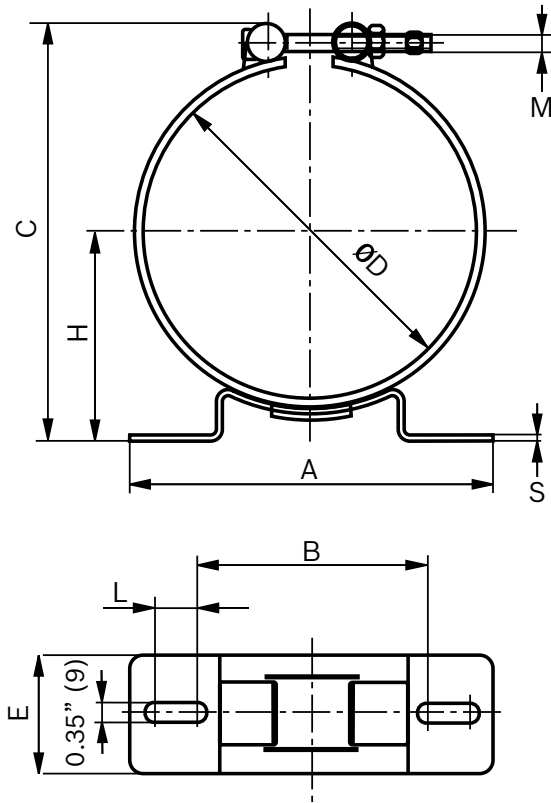

Type F2

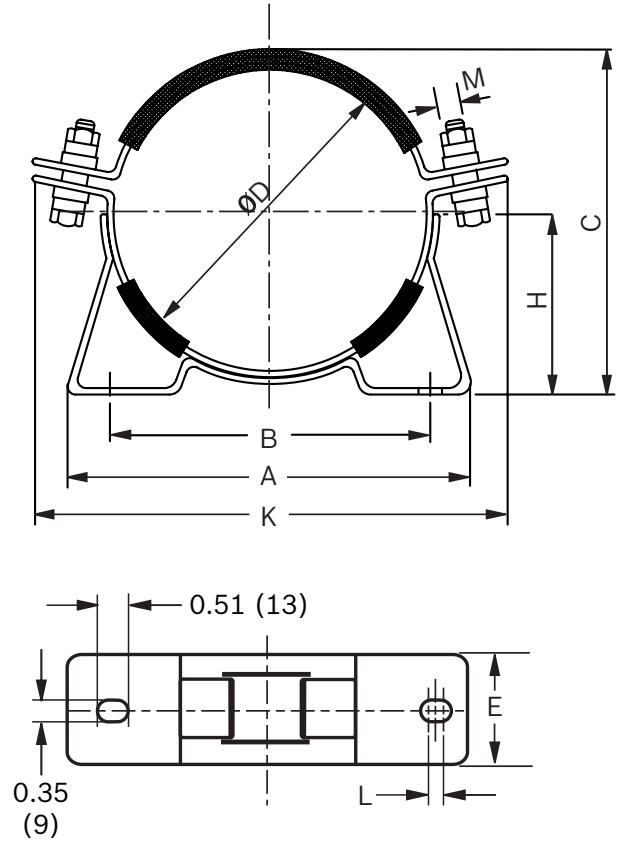

Clamp type		Dimensions in inches (mm)										Part number
		A	B	C	ØD	E	H	K	L	M	S	
Clamp 1 Qt.	F1	5.32 (135)	3.78 (96)	5.91 (150)	4.33-4.72 (110-120)	1.97 (50)	2.52-2.62 (64-69)	-	0.24 (6)	M8	0.12 (3)	1531316021
Clamp 1 Gal.	F1	9.33 (237)	5.79 (147)	7.87 (200)	6.30-6.69 (160-170)	1.97 (50)	3.54-3.74 (90-95)	-	0.70 (18)	M8	0.16 (4)	1531316022
Clamp 2.5-15 Gal.	F2	10.00 (254)	8.5 (216)	9.61 (244)	8.82-9.05 (224-230)	1.18 (30)	4.72-4.84 (120-123)	11.61 (295)	0.16 (4)	M12	0.12 (3)	1531316005

Mounting bracket and clamp, 5000/6000 PSI HAB-7X ASME/CRN

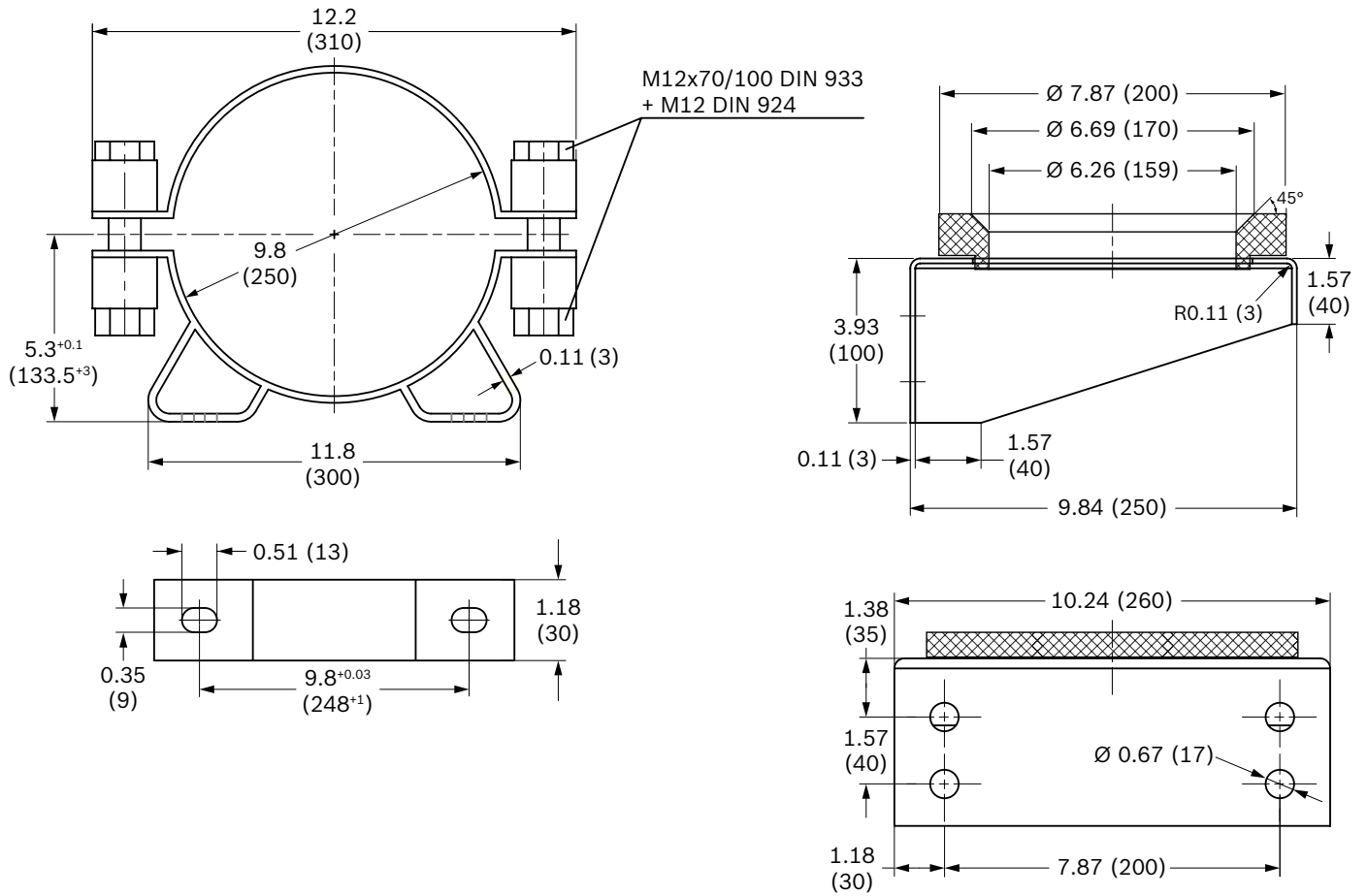

Accessory	Part number	Accumulator size			
		2.5 gal	5 gal	10 gal	15 gal
Clamp	R901435475	1	1	2	2
Mounting bracket	R978060354	1	1	1	1

Note: Mounting bracket is supplied with a dampening insert.

Pressure monitoring

Permanent gauge block assemblies

Part Number: R978048583

Assembly torque value to install gauge
block on accumulator: 50 in-lbs

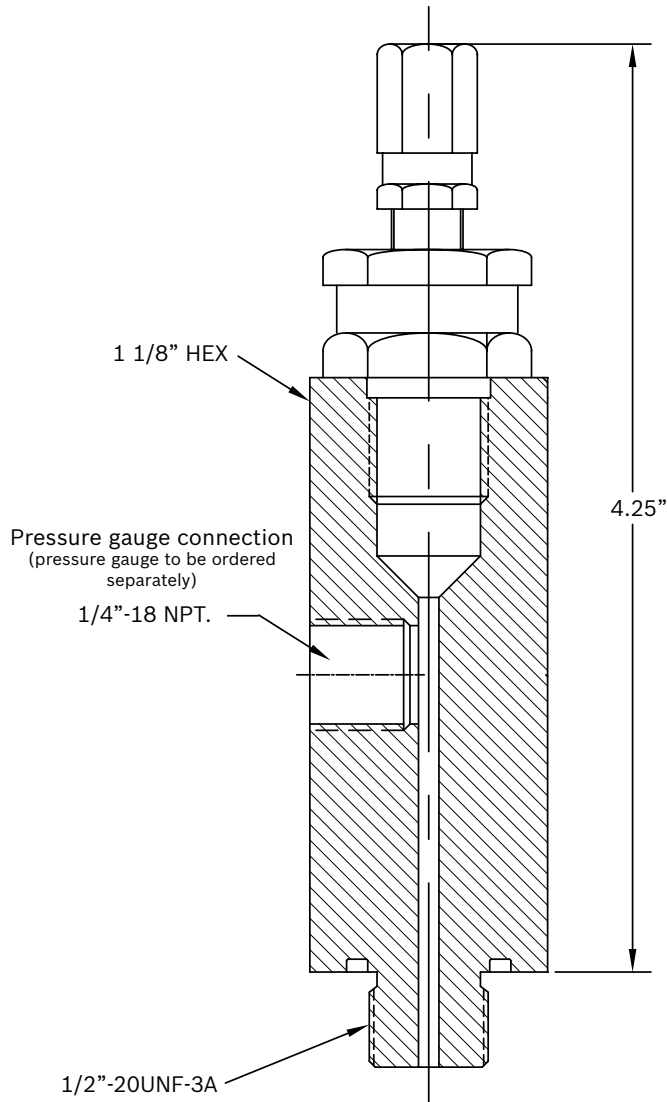

Pressure gauge part numbers:

3000 PSI pressure gauge
1/4" NPT male, back/rear mount
Part number: R978057418

5000 PSI pressure gauge
1/4" NPT male, back/rear mount
Part number: R978057419

Filling and test device

Charge kit for bladder-type accumulator (HAB-7X)

Part Number: R978046091

Assembly torque value to install air chuck (item 6) to the accumulator: 75 in-lbs

Designed for use on both bottom and top repairable units.

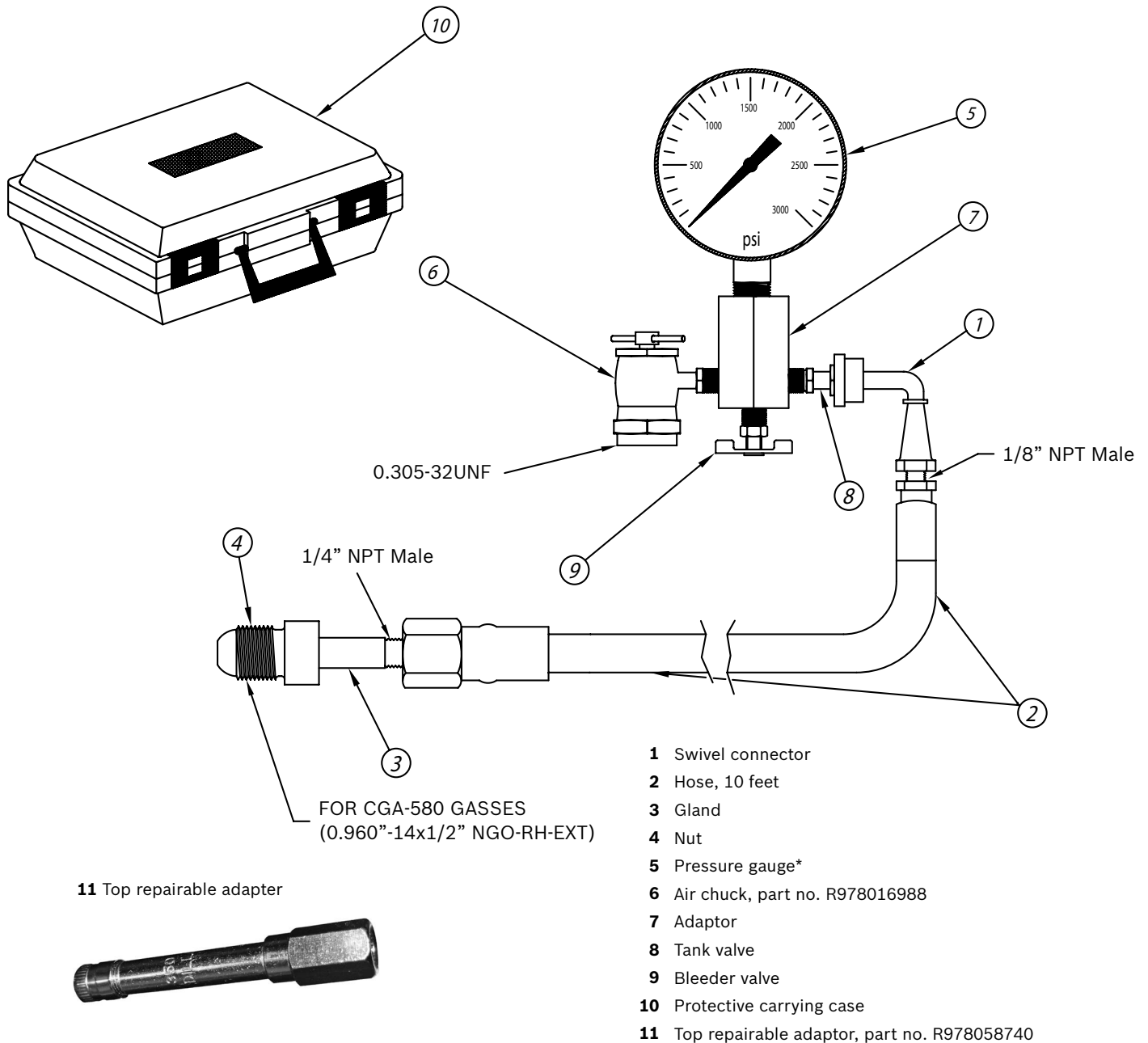

*R978046091 kit is supplied with two pressure gauges, 3000 PSI and 5000 PSI.

Please use the appropriate gauge depending on pre-charge pressure.

Charge kit is supplied with a CGA-580 gas bottle connection which is rated up to 3000 psi. If high pressure nitrogen bottles will be used, a CGA-680 connection is required which is rated for 3001–5500 psi. Two additional parts must be ordered separately for this CGA-680 connection, gland nut (R978053670) and gland (R978053671).

Accumulator installation & operating instructions

For complete information about HAB-7X installation and operation, please see RA 50175-B/07.2016.

Additional spare parts information

For additional spare parts information for the HAB-7X accumulator, please see RA 50175-S to be published in 2017.

Notes

Notes

Bosch Rexroth Corp.

Hydraulics

2315 City Line Road

Bethlehem, PA 18017

U.S.A.

Telephone (610) 694-8300

Facsimile (610) 694-8467

www.boschrexroth-us.com

© All rights reserved Bosch Rexroth Corp. This document, as well as the data, specifications and other information set forth in it, are the exclusive property of Bosch Rexroth Corp. It may not be reproduced or given to third parties with its consent.

The data specified above only serve to describe the product. No statements concerning a certain condition or suitability for a certain application can be derived from our information. The information given does not release the user from the obligation of own judgment and verification. It must be remembered that our products are subject to a natural process of wear and aging.