

R310EN 2202 (2004.06)

Ball Rail Systems

The Drive & Control Company

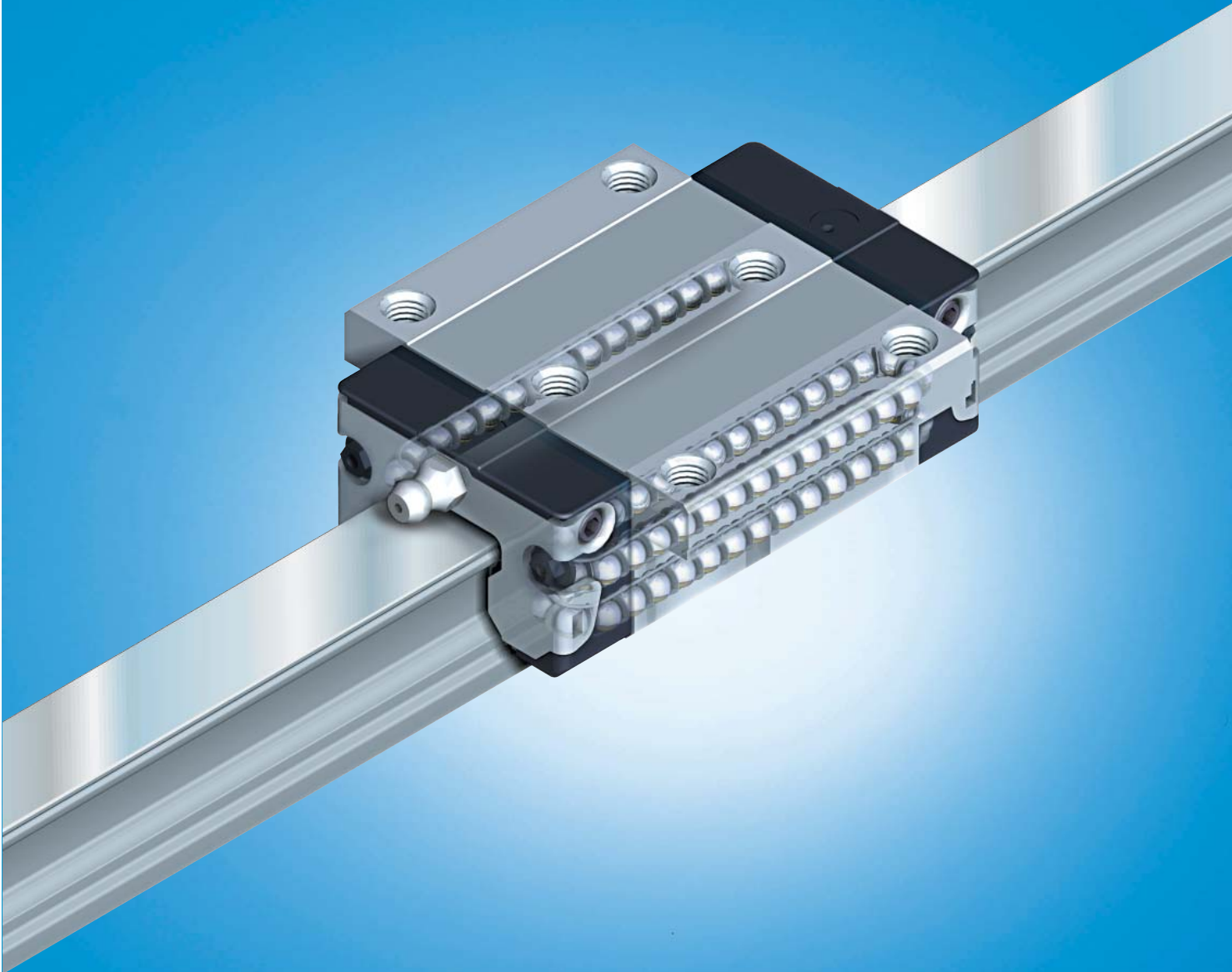

Rexroth Linear Motion Technology

Ball Rail Systems	<ul style="list-style-type: none"> Standard Ball Rail Systems Super Ball Rail Systems Ball Rail Systems with Aluminium Runner Block High-speed Ball Rail Systems Corrosion-resistant Ball Rail Systems Wide Ball Rail Systems <hr/> <ul style="list-style-type: none"> Ball Rail Systems with Integrated Measuring System Clamp and Brake Units for Ball Rail Systems Racks for Ball Rail Systems Miniature Ball Rail Systems Cam Roller Guides
Roller Rail Systems	<ul style="list-style-type: none"> Standard Roller Rail Systems Wide Roller Rail Systems High-load Roller Rail Systems Roller Rail Systems with Integrated Measuring System Clamp and Brake Units for Roller Rail Systems Racks for Roller Rail Systems
Linear Bushings and Shafts	<ul style="list-style-type: none"> Linear Bushings, Linear Sets Shafts, Shaft Support Rails, Shaft Support Blocks <hr/> <ul style="list-style-type: none"> Ball Transfer Units Traditional Technical Parts
Ball Screw Assemblies	
Linear Motion Systems	<ul style="list-style-type: none"> Linear Motion Slides <ul style="list-style-type: none"> – Ball Screw – Toothed Belt Linear Modules <ul style="list-style-type: none"> – Ball Screw – Toothed Belt – Gear Rack – Pneumatic Drive – Linear Motor Compact Modules <ul style="list-style-type: none"> – Ball Screw – Toothed Belt – Linear Motor Precision Modules <ul style="list-style-type: none"> – Ball Screw Ball Rail Tables <ul style="list-style-type: none"> – Ball Screw – Linear Motor
<ul style="list-style-type: none"> Controllers, Motors, Electrical Accessories Electric Cylinders 	

General Product Description

Overview of Load Capacities and Rail Lengths	4
Product Description	16
General Technical Data	18
Technical Calculations	20
Accuracy Classes	22
System Preload	24

Runner Blocks, Steel Version and Resist NR

Product Description	26
Flange Standard FNS	28, 32
Flange Long FLS	34, 38
Flange Short FKS	40
Slimline Standard SNS	42, 46
Slimline Long SLS	48, 52

Runner Blocks, Steel Version only

Slimline Short SKS	54
Slimline High SNH	56
Slimline Long High SLH	60
Flange Standard, Low Profile FNN	64
Flange Short, Low Profile FKN	66
Slimline Standard, Low Profile SNN	68
Slimline Short, Low Profile SKN	70

Super Runner Blocks Steel Version

Product Description	72
Flange Short FKS	74
Slimline Short SKS	76

Runner Blocks, Aluminium Version

Product Description	78
Flange Standard FNS	80
Slimline Standard SNS	82

High-speed Runner Blocks

Product Description	84
Flange Standard FNS	86
Slimline Standard SNS	88

Standard Guide Rails

Product Description and Ordering Examples	90
Standard Guide Rails	
With Rail Seal Cover Strip and Strip Holder	92
With Rail Seal Cover Strip and Protective Caps	94
With Plastic Mounting Hole Plugs	96
With Steel Mounting Hole Plugs	98
For mounting from below	100
Hard Chrome Plated Guide Rails - Resist CR	
With Rail Seal Cover Strip and Protective Caps	102
With Plastic Mounting Hole Plugs	104
For mounting from below	106

Ball Rail Systems made of Corrosion-resistant Steel (Resist NR II)

Product Description	108
Runner Blocks	
Flange Standard FNS	110
Slimline Standard SNS	112

Guide Rails made of Corrosion-resistant Steel (Resist NR II)

Guide Rails (Resist NR II)	
With Rail Seal Cover Strip and Strip Holder	114
With Plastic Mounting Hole Plugs	116
For Mounting from Below	118

Accessories for Standard Runner Blocks

Overview of Accessories and Allocation	120
Scraper Plates	122
Lubrication Plates	123
Front Seals	124
Bellows	125
Lubrication Adapters	127
Front Lube Units	129

Accessories for Standard Guide Rails

Overview of Accessories and Allocation	133
Notes on rail seal cover strip	134
Mounting Rail Seal Cover Strip and Strip Holder	136
Mounting Hole Plugs	139

Wide Ball Rail Systems

Product Description	140
Wide Runner Blocks	
Wide Low Profile BNN	142
Wide Guide Rails	
With Plastic Mounting Hole Plugs	144
For Mounting from Below	146

Accessories for Wide Ball Rail Systems

Accessories in General	
Overview and Allocation	138
Lube Nipple, Reducing Elements, Lubricant	139
Wedge-Profile Retaining Strips for Guide Rails	142

Mounting Instructions

General Mounting Instructions	157
for Standard Runner Blocks	158
for Super Runner Blocks 	160
for Wide Runner Blocks	162
Mounting Screws for Guide Rail Base	163
Vertical Offset	164
Parallelism of Guide Rails	166
Composite Guide Rails	167
Maintenance and Lubrication	
Maintenance	168
Grease Lubrication	168
Oil Lubrication	169
Mounting at Angles and at Sides	170
Lubricating from above without Lubrication Adapter	171

Overview of Load Capacities

Runner Blocks, Steel Version

Page

**Standard Runner Blocks,
Steel Version**

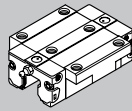

Flange Standard FNS
R1651
R2001

28

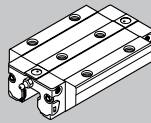
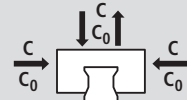

Flange Long FLS
R1653
R2002

34

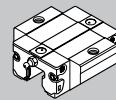
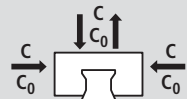

Flange Short FKS
R1665
R2000

40

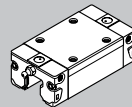
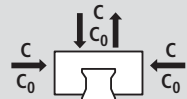

Slimline Standard SNS
R1622
R2011

42

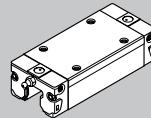
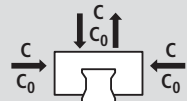

Slimline Long SLS
R1623
R2012

48

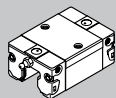
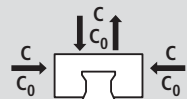

Slimline Short SKS
R1666
R2010

54

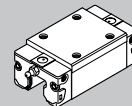
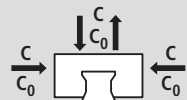

Slimline High SNH
R1621

58

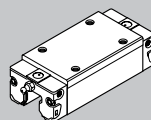
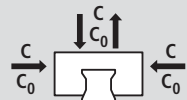

Slimline Long High SLH
R1624

60

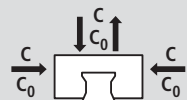

Size	15	20	25	30	35	45	55	65	
Version									
Without chain C (N)	7 800	18 800	22 800	31 700	41 900	68 100	98 200	123 000	
With chain C (N)	7 280	17 400	21 300	29 300	41 900	63 300	–	–	
Without chain C₀ (N)	13 500	24 400	30 400	41 300	54 000	85 700	121 400	192 700	
With chain C ₀ (N)	12 100	21 700	27 300	37 200	54 000	77 100	–	–	
Without chain C (N)	10 000	24 400	30 400	40 000	55 600	90 400	124 200	163 000	
With chain C (N)	9 000	23 100	27 500	38 000	53 000	81 900	–	–	
Without chain C₀ (N)	20 200	35 200	45 500	57 800	81 000	128 500	170 000	289 000	
With chain C ₀ (N)	17 500	32 500	39 500	53 700	75 600	111 400	–	–	
Without chain C (N)	5 400	12 400	15 900	22 100	29 300	–	–	–	
With chain C (N)	4 600	12 400	14 000	22 100	29 300	–	–	–	
Without chain C₀ (N)	8 100	13 600	18 200	24 800	32 400	–	–	–	
With chain C ₀ (N)	6 700	13 600	15 200	24 800	32 400	–	–	–	
Without chain C (N)	7 800	18 800	22 800	31 700	41 900	68 100	98 200	123 000	
With chain C (N)	7 280	17 400	21 300	29 300	41 900	63 300	–	–	
Without chain C₀ (N)	13 500	24 400	30 400	41 300	54 000	85 700	121 400	192 700	
With chain C ₀ (N)	12 100	21 700	27 300	37 200	54 000	77 100	–	–	
Without chain C (N)	10 000	24 400	30 400	40 000	55 600	90 400	124 200	163 000	
With chain C (N)	9 000	23 100	27 500	38 000	53 000	81 900	–	–	
Without chain C₀ (N)	20 200	35 200	45 500	57 800	81 000	128 500	170 000	289 000	
With chain C ₀ (N)	17 500	32 500	39 500	53 700	75 600	111 400	–	–	
Without chain C (N)	5 400	12 400	15 900	22 100	29 300	–	–	–	
With chain C (N)	4 600	12 400	14 000	22 100	29 300	–	–	–	
Without chain C₀ (N)	8 100	13 600	18 200	24 800	32 400	–	–	–	
With chain C ₀ (N)	6 700	13 600	15 200	24 800	32 400	–	–	–	
Without chain C (N)	7 800	–	22 800	31 700	41 900	68 100	98 200	–	
With chain C (N)	7 280	–	21 300	29 300	41 900	63 300	–	–	
Without chain C₀ (N)	13 500	–	30 400	41 300	54 000	85 700	121 400	–	
With chain C ₀ (N)	12 100	–	27 300	37 200	54 000	77 100	–	–	
Without chain C (N)	–	–	30 400	40 000	55 600	90 400	124 200	–	
With chain C (N)	–	–	27 500	38 000	53 000	81 900	–	–	
Without chain C₀ (N)	–	–	45 500	57 800	81 000	128 500	170 000	–	
With chain C ₀ (N)	–	–	39 500	53 700	75 600	111 400	–	–	

Basis for load capacities:

Determination of dynamic load capacity C is based on a travel life of 100,000 m to DIN 636.

However, frequently this is determined on the basis of only 50 000 m. The specified values C are then to be multiplied by 1.26.

Overview of Load Capacities

Runner Blocks, Aluminium Version and Steel Version

Page

Low Profile Runner Blocks,
Steel Version

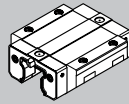

Flange Standard,
Low Profile FNN
R1693

52

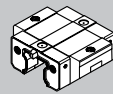
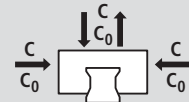

Flange Short,
Low Profile FKN
R1663

64

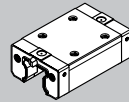
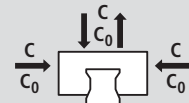

Slimline Standard,
Low Profile SNN
R1694

66

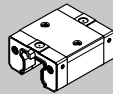
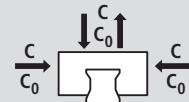

Slimline Short,
Low Profile SKN
R1664

70

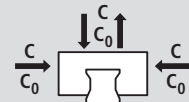

Super Runner Blocks ,
Steel Version with
Self-aligning Feature

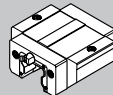

Flange Short FKS
R1661

74

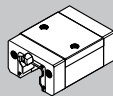
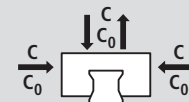

Slimline Short SKS
R1662

76

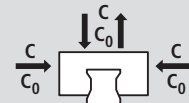

Standard Runner Blocks,
Aluminium Version

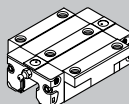

Flange Standard FNS
R1631

80

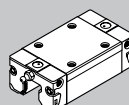
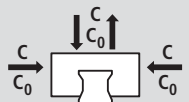

Slimline Standard SNS
R1632

82

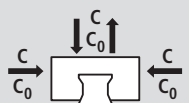

Size	15	20	25	30	35	45	55	65
Version								
Without chain C (N)	–	14 500	22 800	–	–	–	–	–
Without chain C0(N)	–	24 400	30 400	–	–	–	–	–
Without chain C (N)	–	9 600	15 900	–	–	–	–	–
Without chain C0(N)	–	13 600	18 200	–	–	–	–	–
Without chain C (N)	–	14 500	22 800	–	–	–	–	–
Without chain C0(N)	–	24 400	30 400	–	–	–	–	–
Without chain C (N)	–	9 600	15 900	–	–	–	–	–
Without chain C0(N)	–	13 600	18 200	–	–	–	–	–
Without chain C (N)	3 900	10 100	11 400	15 800	21 100	–	–	–
Without chain C (N)	3 900	10 100	11 400	15 800	21 100	–	–	–
Without chain C (N)	7 800	18 800	22 800	31 700	41 900	–	–	–
With chain C (N)	7 280	17 400	21 300	29 300	41 900	–	–	–
Without chain C (N)	7 800	18 800	22 800	31 700	41 900	–	–	–
With chain C (N)	7 280	17 400	21 300	29 300	41 900	–	–	–

Basis for load capacities:

Determination of dynamic load capacity C is based on a travel life of 100,000 m to DIN 636.

However, frequently this is determined on the basis of only 50,000 m. The specified values C are then to be multiplied by 1.26.

Overview of Load Capacities

Runner Blocks, Steel Version

High-speed Runner Block, Steel Version

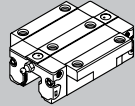

Flange Standard
FNS
R2001

Page

86

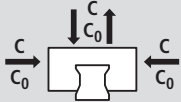
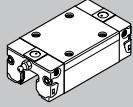
Slimline Standard
SNS
R2011

88

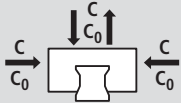

Size	15	20	25	30	35	45	55	65
Version								
Without chain C (N)	5 300	12 700	15 500	21 500	28 500	–	–	–
Without chain C0(N)	9 100	16 500	20 600	28 000	36 700	–	–	–
Without chain C (N)	5 300	12 700	15 500	21 500	28 500	–	–	–
Without chain C0(N)	9 100	16 500	20 600	28 000	36 700	–	–	–

Basis for load capacities:

Determination of dynamic load capacity C is based on a travel life of 100,000 m to DIN 636.

However, frequently this is determined on the basis of only 50,000 m. The specified values C are then to be multiplied by 1.26.

Overview of Rail Lengths

Standard Guide Rails

Standard Guide Rails, Steel Version

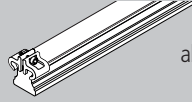
 For mounting from above, with rail seal cover strip and strip holder
R1605 .3. ..

Page
92

 For mounting from above, with rail seal cover strip and protective caps
R1605 .6. ..

94

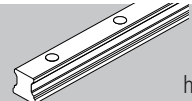
 For mounting from above, with mounting hole plugs, plastic version
R1605 .0. ..

96

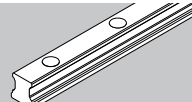
 For mounting from above, with mounting hole plugs, steel version
R1606 .5. ..

98

 For mounting from below
R1607

100

Standard Guide Rails, Thin Dense Chrome Plated - Resist CR

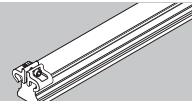
 For mounting from above with cover strip – thin dense chrome plated
R1645 .33. ..

102

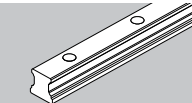
 For mounting from above – thin dense chrome plated
R1645 .03. ..

104

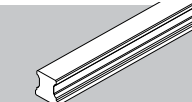
 For mounting from below – thin dense chrome plated
R1647 .03. ..

106

Overview of Load Capacities

Ball Rail Systems Made of Corrosion-resistant Steel

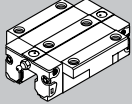
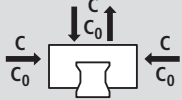
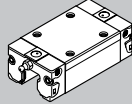
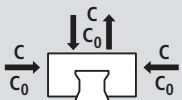
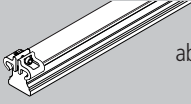
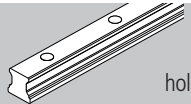
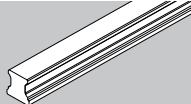
		Page
Runner Blocks Made of Corrosion-resistant Steel Resist NR II	 <p>Flange Standard FNS R2001</p>	110 
	 <p>Slimline Standard SNS R2011</p>	112 
Guide Rails Made of Corrosion-resistant Steel Resist NR II	 <p>For mounting from above, with rail seal cover strip and strip holder R2045 .3. ..</p>	114
	 <p>For mounting from above, with mounting hole plugs plastic (or steel) R2045 .0. ..</p>	116
	 <p>For mounting from below R2047</p>	118
Accessories for Standard Guide Rails	<p>Bosch Rexroth offers a wide selection of accessories. A total overview of these is in the Accessories Section.</p>	120

Size		15	20	25	30	35	45
Version		Load capacities					
Without chain	C (N)	5 100	12 300	15 000	20 800	27 600	–
With chain	C (N)	4 700	11 400	14 000	19 300	27 600	–
Without chain	C₀ (N)	9 300	16 900	21 000	28 700	37 500	–
With chain	C ₀ (N)	8 400	15 000	18 900	25 800	37 500	–
Without chain	C (N)	5 100	12 300	15 000	20 800	27 600	–
With chain	C (N)	4 700	11 400	14 000	19 300	27 600	–
Without chain	C₀ (N)	9 300	16 900	21 000	28 700	37 500	–
With chain	C ₀ (N)	8 400	15 000	18 900	25 800	37 500	–

Basis for load capacities:

Determination of dynamic load capacity C is based on a travel life of 100,000 m to DIN 636.

However, frequently this is determined on the basis of only 50 000 m. The specified values C are then to be multiplied by 1.26.

Note on runner block with ball chain: The permissible moment loads decrease by the same relation as do the load capacities.

Size	15	20	25	30	35	45
Maximum unit length (mm)						
	2 000	2 000	4 000	4 000	4 000	–
	2000	2 000	4 000	4 000	4 000	–
	2 000	2 000	4 000	4 000	4 000	–

Overview of Load Capacities and Rail Lengths

Wide Ball Rail Systems

**Wide Ball Rail Systems
Runner Blocks, Steel Version**

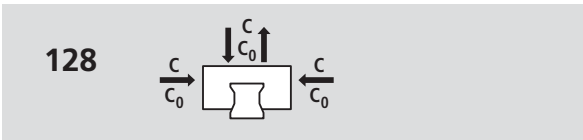
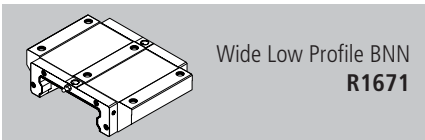

**Wide Ball Rail Systems
Guide Rails**

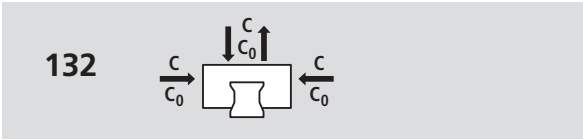
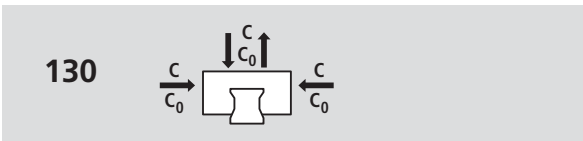
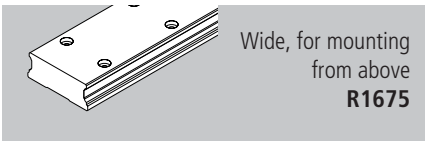

**Accessories for Wide Ball Rail
Systems**

Accessories for Wide Ball Rail Systems,
complementary to the comprehensive
general range of accessories:

134

Size	20/40	25/70	35/90
Version	Load capacities		
Without chain C (N)	15 600	30 400	58 200
Without chain C ₀ (N)	24 100	45 500	86 300

Basis for load capacities:

Determination of dynamic load capacity C is based on a travel life of 100,000 m to DIN 636.

However, frequently this is determined on the basis of only 50,000 m. The specified values C are then to be multiplied by 1.26.

	Maximum unit length (mm)		
		4 000	4 000
	4 000	4 000	4 000

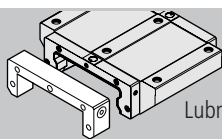

Lubrication plate

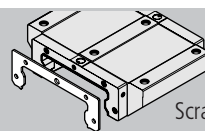

Scraper plates

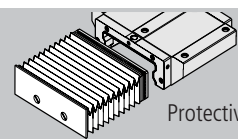

Protective bellows

Product Description

Make up your own compact linear motion guideways from interchangeable standard stock elements...

Rexroth manufactures its guide rails and runner blocks with such high precision, especially in the ball track zone, that each individual component element can be replaced by another at any time. This makes infinite combinations possible within each accuracy class. This enables a high standards of logistics that are unique worldwide. Each element can be individually ordered and separately stocked. Both sides of the guide rail can be used as reference edges.

Highlights:

- Top load capacities in all load directions
- Lowest possible noise level and best running characteristics
- Excellent dynamic characteristics: v up to 5 m/s; a_{\max} up to 500 m/s²
- New: high-speed version $v_{\max} = 10$ m/s; $a_{\max} = 500$ m/s²
- Long-term lubrication, up to several years
- Minimum quantity lubrication system with integrated reservoir for oil lubrication
- Lube ports with metal threads on all sides
- Limitless interchangeability due to standardized guide rails with or without rail seal cover strip, for all runner block versions
- Optimum system rigidity through preloaded O-arrangement
- Optimum installation error compensation with super runner block
- 60 % weight saving with Aluminium runner block compared to the steel version
- Interchangeability with Rexroth roller rail system (overall system dimensions)
- Integrated, inductive and wear-free measuring system as an option
- Comprehensive range of accessories
- Runner block can be bolted from above or below *
- Improved rigidity under lift-off and side loading conditions when additional mounting screws are used in holes provided at the center of the runner block *
- Guide rails and runner blocks also available with surface protection as an option
- Front face securing threads for all attachments
- High rigidity in all load directions – can therefore be used in single bearing applications
- Integral, all-round sealing
- High torque load capacity
- Optimized entry-zone geometry and the high number of balls per track greatly reduce variation in elastic deflection
- Smooth, light running due to optimized ball recirculation and ideal ball/ball chain track geometry
- Various preload classes
- New: corrosion-resistant steel version of runner block and guide rail complying with DIN EN 10088

Proven rail seal cover strip for guide rail mounting holes:

- One cover for all holes, saves time and costs
- Made of corrosion-resistant spring steel
DIN EN 10088
- Easy, secure mounting
- Clip-on and fasten

* depends on type

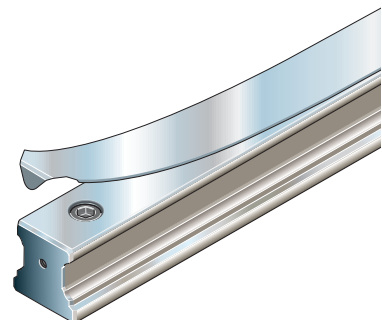

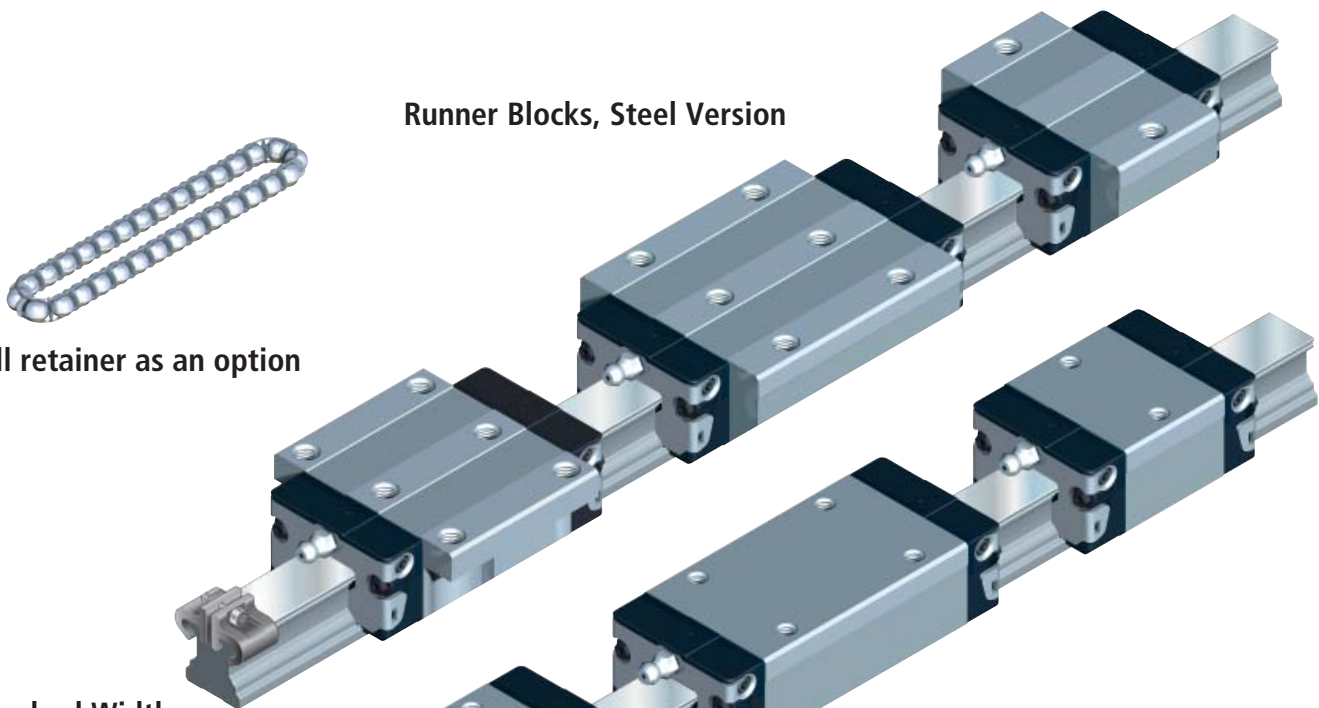

Ball retainer as an option

Standard Width

Slimline Runner Block

Wide Ball Rail Systems

Super Runner Blocks 

Ball Rail Systems made of Corrosion-resistant Steel

High-speed Runner Block, Steel Version

Runner Blocks, Aluminium Version

General Technical Data and Calculations

General Notes

The general technical data and calculations apply to all ball rail systems (all runner blocks and rails).

Specific technical data referring to the individual types is given separately.

Preload classes

With the various application requirements in mind, Rexroth Ball Rail Systems are available in four different preload classes.

So as not to reduce the service life, the preload should not exceed 1/3 of the load on bearing F.

In general, the rigidity of the runner block rises with increasing preload.

Guide Systems with Parallel Rails

- for the selected preload class, also comply with the permitted parallelism deviation of the rails (see tables for each version).
- When specifying ball rail systems of

accuracy class N, we recommend the version with clearance or preload class 0.02C to avoid incorrect preloads due to the tolerances.

Speed

$$v_{\max} : 3 \text{ to } 10 \text{ m/s}$$

For exact values, refer to the individual runner block.

Acceleration

$$a_{\max} : 250 \text{ to } 500 \text{ m/s}^2$$

For exact values, refer to the individual runner block.

Only in the case of preloaded systems.

In the case of non-preloaded systems.

$$a_{\max} = 50 \text{ m/s}^2$$

Temperature resistance

$$t_{\max} = 100 \text{ }^{\circ}\text{C}$$

Maximum value, only permitted for brief period.

In continuous operation, do not exceed the maximum temperature of 80 °C.

Friction

The friction coefficient μ of Rexroth Ball Rail Systems is approx. 0.002 to 0.003 (without friction of the seals).

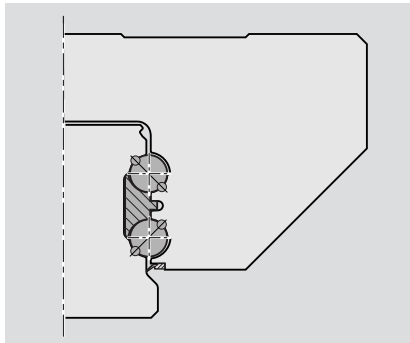

Rexroth's special design with 4 ball circuits ensures that the balls make contact at **two points** regardless of the direction of loading.

This reduces the friction to a minimum.

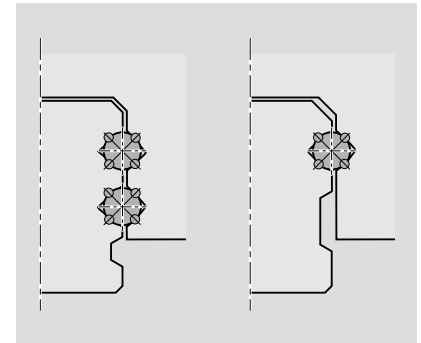

Other ball rail systems with 2 or 4 ball circuits with **4-point contact** have multiple friction: the differential slip at side loading of the Gothic track zone profile shape as well as with comparable preload without load causes higher friction (depending on osculation and load up to approx. 5 times the frictional value).

This high friction leads to correspondingly greater heat.

Seals

The purpose of seals is to prevent dirt, swarf etc. from penetrating inside the runner block and thus shortening its service life.

Universal Seals

Universal seals are incorporated as standard in Rexroth Runner Blocks.

They provide equal sealing performance on guide rails with and without rail seal cover strips.

Low friction combined with a good sealing effect was an important factor during design.

Suitable for applications requiring good sealing.

Special low-friction seals are available on request.

Front Seal

Front seals can be ordered separately as accessories for mounting by the customer.

Viton and NBR seals can be ordered separately for mounting by the customer.

For use in environments with fine dirt or metal particles and cooling or cutting fluids.

For extreme use in environments with coarse dirt or metal particles or where cooling or cutting fluids are used intensively.

Scraper plate

Scraper plates can be ordered separately as accessories for mounting by the customer.

For use in environments subject to coarse dirt or swarf.

General Technical Data and Calculations

Definition of dynamic load capacity C

The radial loading of constant magnitude and direction which a linear rolling bearing can theoretically endure for a nominal life of 10^5 meters distance traveled (to DIN 636 Part 2).

The dynamic load capacities given in the tables are mostly 30% above DIN values. They have been proven in tests.

Definition of static load capacity C0

Static load in the load direction that corresponds to a calculated load in the center of the contact point with the greatest load between the rolling element and track zone (guide rail) with an osculation of 0.52, 4200 MPa.

Note:
With this load on the contact point, a permanent overall deformation of the rolling element and track zone occurs, corresponding to around 0.0001 times the roller body diameter (complying with DIN 636 part 2).

Definition and calculation of the nominal life

The calculated life for an individual roller bearing or a group of obviously identical rolling element that can be achieved with 90% probability under equal conditions

using generally used material of normal manufacturer quality and under the usual operating conditions (complying with DIN 636 part 2).

Calculate the nominal life L or L_h according to the formulas (1), (2) or (3):

Nominal life at constant speed

<p>(1) $L = \left(\frac{C}{F}\right)^3 \cdot 10^5$</p> <p>(2) $L_h = \frac{L}{2 \cdot s \cdot n \cdot 60}$</p>	<p>L = nominal life (m)</p> <p>L_h = nominal life (h)</p> <p>C = dynamic load capacity (N)</p> <p>F = equivalent load (N)</p> <p>s = travel length (m)</p> <p>n = travel frequency (cycles/min) rpm (min^{-1})</p>
----------------------------------------------------------------------------------------------------------------------------------------------------------------------	-----------------------------------------------------------------------------------------------------------------------------------------------------------------------------------------------------------------------------------------------------

Nominal life at varying speed

<p>(3) $L_h = \frac{L}{60 \cdot v_m}$</p> <p>(4) $v_m = \frac{t_1 \cdot v_1 + t_2 \cdot v_2 + \dots + t_n \cdot v_n}{100}$</p>	<p>L = nominal life (m)</p> <p>L_h = nominal life (h)</p> <p>v_m = medium speed (m/min)</p> <p>$v_1, v_2 \dots v_n$ = travel speeds (m/min)</p> <p>$t_1, t_2 \dots t_n$ = time proportions for $v_1, v_2 \dots v_n$ (%)</p>
--------------------------------------------------------------------------------------------------------------------------------------------------------------------------------------	----------------------------------------------------------------------------------------------------------------------------------------------------------------------------------------------------------------------------------------------------------------------------------------

Dynamic equivalent load on bearing for calculation of life

– with variable load on bearing

With variable load on bearing, calculate the dynamic equivalent load F according to the formula (5):

<p>(5) $F_1 = \sqrt[3]{F_1^3 \cdot \frac{q_1}{100} + F_2^3 \cdot \frac{q_2}{100} + \dots + F_n^3 \cdot \frac{q_n}{100}}$</p>	<p>F = equivalent load (N)</p> <p>$F_1, F_2 \dots F_n$ = stepped single load (N)</p> <p>$q_1, q_2 \dots q_n$ = cycle proportion for $F_1, F_2 \dots F_n$ (%)</p>
---------------------------------------------------------------------------------------------------------------------------------------------------------	---------------------------------------------------------------------------------------------------------------------------------------------------------------------------------------------------

– with combined load on bearing

The equivalent dynamic load – F resulting from combined vertical and horizontal – loads is calculated according to the formula (6):

Note:
the structure of the ball rail system permits this simplified calculation.

$$(6) \quad F = |F_V| + |F_H|$$

F	= dyn. equivalent load	(N)
F_V	= dynamic external load, vertical	(N)
F_H	= dynamic external load, horizontal	(N)

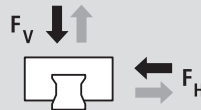

Note

If F_V and F_H involve several different load levels, they have to be calculated separately using formula (5).

An external load acting at an angle on the runner block is to be broken down into its F_V and F_H components and these values are then used in formula (6).

– with combined load on bearing in conjunction with a torsion moment

With combined external load – vertical and horizontal – in conjunction with a torsion moment, calculate the dynamic equivalent load F according to formula (7):

Formula (7) only applies if a single guide rail is used.

$$(7) \quad F = |F_V| + |F_H| + C \cdot \frac{|M|}{M_t}$$

F	= dyn. equivalent load	(N)
F_V, F_H	= dyn. external loads	(N)
M	= dyn. torsion moment	(Nm)
C	= dynamic load capacity *	(N)
M_t	= Permissible dyn. moment*	(Nm)
	* see tables	

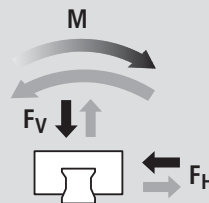

Note

If F_V and F_H involve several different load levels, they have to be calculated separately using formula (5).

An external load acting at an angle on the runner block is to be broken down into its F_V and F_H components and these values then used in formula (7).

Static equivalent load on bearing

With combined external static load – vertical and horizontal – in conjunction with a static torsion moment, calculate the static equivalent load F_0 according to formula (8).

The static equivalent load F_0 must not exceed the static load capacity C_0 .

Formula (8) only applies if a single guide rail is used.

$$(8) \quad F_0 = |F_{V0}| + |F_{H0}| + C_0 \cdot \frac{|M_0|}{M_{t0}}$$

F_0	= equivalent static load	(N)
F_{V0}, F_{H0}	= external static loads	(N)
M_0	= stat. torsion moment	(Nm)
C_0	= static load capacity *	(N)
M_{t0}	= permissible static moment *	(Nm)
	* see tables	

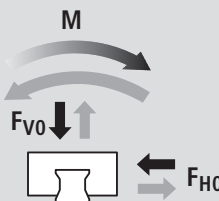

Note

An external load acting at any angle on the runner block is to be broken down into its F_{V0} and F_{H0} components and these values are then used in formula (8).

Selection Criteria Accuracy Class

Accuracy classes and their tolerances (µm)

Rexroth Ball Rail Systems are offered in up to five different accuracy classes.

For available versions see table "Part Numbers".

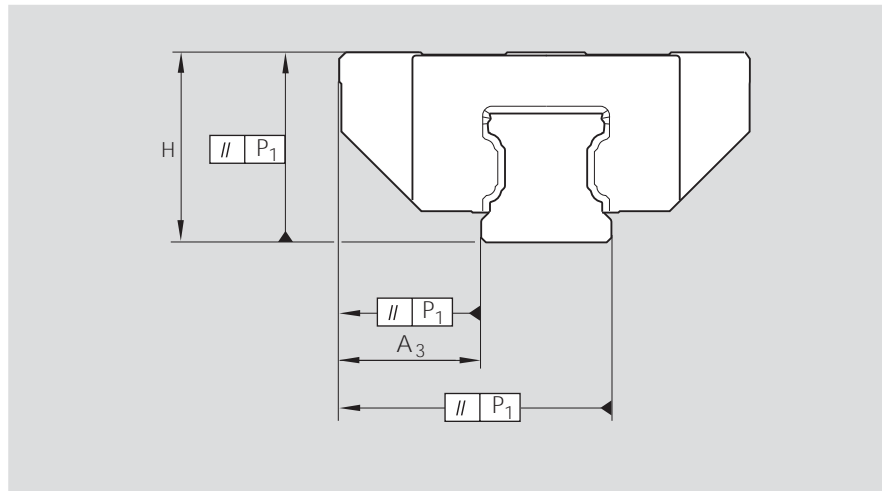

Built-in interchangeability through precision machining

Rexroth manufactures its guide rails and runner blocks with such high precision, especially in the ball track zone, that each individual component element can be replaced by another at any time.

A runner block can be used without problems on various guide rails of the same size, for example.

This applies equally to the use of different runner blocks on one and the same guide rail.

* Tolerances for the combination of different accuracy classes for runner blocks and guide rails are available on request

Accuracy classes	Tolerances* dimensions H and A ₃ (µm)		Max. difference in dimension H and A ₃ on one guide rail ΔH, ΔA ₃ (µm)
	H	A ₃	
N	± 100	± 40	30
H	± 40	± 20	15
P	± 20	± 10	7
XP	± 11	± 8	7
SP ²⁾	± 10	± 7	5
UP	± 5	± 5	3

Measured at middle of runner block:

For any runner block/rail combination at any position on rail

For different runner blocks at same position on rail

Parallelism offset P₁ of the ball rail system in service

Measured at middle of runner block

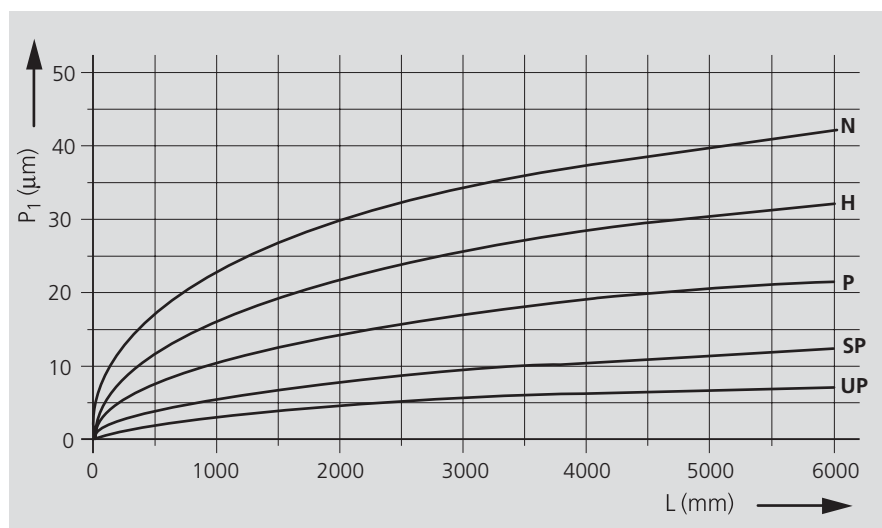

Key to Illustration

P₁ = parallelism offset
L = rail length

Selection Criteria Combination Accuracy Class

Runner Block	Rails	N µm	H µm	P µm	SP µm	UP µm
N	Tolerance Dimension H (µm)	+/- 100	+/- 48	+/- 32	+/- 23	+/- 19
	Tolerance Dimension A3 (µm)	+/- 40	+/- 28	+/- 22	+/- 20	+/- 19
	Max. difference in Dimension H und A3 on one guide rail (µm)	30	30	30	30	30
H	Tolerance Dimension H (µm)	+/- 88	+/- 40	+/- 23	+/- 23	+/- 19
	Tolerance Dimension A3 (µm)	+/- 33	+/- 20	+/- 14	+/- 20	+/- 19
	Max. difference in Dimension H und A3 on one guide rail (µm)	15	15	15	15	15
P	Tolerance Dimension H (µm)	+/- 84	+/- 34	+/- 21	+/- 11	+/- 7
	Tolerance Dimension A3 (µm)	+/- 28	+/- 16	+/- 10	+/- 8	+/- 7
	Max. difference in Dimension H und A3 on one guide rail (µm)	7	7	7	7	7
XP	Tolerance Dimension H (µm)	+/- 84	+/- 34	+/- 21	+/- 11	+/- 7
	Tolerance Dimension A3 (µm)	+/- 28	+/- 16	+/- 10	+/- 8	+/- 7
	Max. difference in Dimension H und A3 on one guide rail (µm)	15	15	7	7	7
SP	Tolerance Dimension H (µm)	+/- 83	+/- 33	+/- 19	+/- 10	+/- 6
	Tolerance Dimension A3 (µm)	+/- 27	+/- 15	+/- 9	+/- 7	+/- 6
	Max. difference in Dimension H und A3 on one guide rail (µm)	5	5	5	5	5
UP	Tolerance Dimension H (µm)	+/- 82	+/- 32	+/- 18	+/- 9	+/- 5
	Tolerance Dimension A3 (µm)	+/- 26	+/- 14	+/- 8	+/- 6	+/- 5
	Max. difference in Dimension H und A3 on one guide rail (µm)	3	3	3	3	3

Recommendation of combination of accuracy classes

Recommended for short strokes and small runner block-spacing:

runner blocks in a higher accuracy class than the guide rail.

Recommended for long strokes and larger runner block-spacing:

Guide rails in a higher accuracy class than the runner block.

Selection criteria movement accuracy

Runner Blocks of accuracy classes XP, SP and UP provide unmatched travel accuracy due to perfected run-in and run-out zones. These high accuracy bearings are especially suitable for high-precision machining processes, measurement systems, high-precision scanners, grinding systems etc.

Selection Criteria Preload

Definition of the preload class

Preloading force based on the dynamic carrying capacity C_{dyn} of the respective runner blocks.

Example:

Runner Block R1651 314 20

$C_{dyn} = 41\,900\text{ N}$

Preload 0,02 C = 838 N

This Runner block is preloaded with a base load of approximately 838 N.

Selection of the preload class

On the versions with clearance, no preload is achieved. It is more often the case that there is clearance between the runner block and guide rail of between 1 to 10 μm . If you use two rails and more than one runner block per guide rail, this clearance is usual equalized by parallelism tolerances.

Code	Version	Application Area
C0	without Preload	For especially smooth guide systems with the lowest possible friction and minimal outside influences. Clearance versions are available only in class N and H.
C1	Preload 0,02 C	For precise guide systems with minimal external loading and high demands on overall rigidity,
C2	Preload 0,08 C	For precise guide systems with both high external loading and high demands on overall rigidity; recommended for single rail systems. Above average moment loads can be absorbed without significant elastic deformation. Further improved overall rigidity with only medium moment loads.
C3	Preload 0,13 C	For highly rigid guide systems such as precision tooling machine or injection molding closing systems. Above average loads and moments can be absorbed with the least possible elastic deformation. Version with preload 0.13C is available in accuracy classes XP, SP and UP only.

Selection criteria

Runner Block Seals

Selection of Seal types

For moderate and higher loads, the standard seal is always recommended and provides the best sealing effectiveness. In the case of these loads, seal friction is a small proportion of the overall system friction. This seal is also suitable for high dirt accumulation such as metal shavings and other particulate.

The low-friction seal was designed for low-load applications where seal friction represents a larger portion of the overall system friction. This greatly reduces friction for especially light loads.

The seal function is nonetheless fully sufficient to clear away light dirt accumulation, light-weight semiconductor parts and similar.

Front seals and the use of a cover strip for the rail can further improve seal effectiveness against heavy dirt accumulation such as from wood dust.

Selection Criteria Preload

Elastic deformation dependent on the preload class and the runner block

Example:

Runner block FNS, Size 35

- a) Runner block R1651 31. 20 with preload 0.02 C (C1)
- b) Runner block R1651 32. 20 with preload 0.08 C (C2)
- c) Runner block R1651 33. 20 with preload 0.13 C (C3)

Example:

Runner block FLS, Size 35

- a) Runner block R1653 31. 20 with preload 0.02 C (C1)
- b) Runner block R1653 32. 20 with preload 0.08 C (C2)
- c) Runner block R1653 33. 20 with preload 0.13 C (C3)

Example:

Runner block SNS, Size 35

- a) Runner block R1622 31. 20 with preload 0.02 C (C1)
- b) Runner block R1622 32. 20 with preload 0.08 C (C2)
- c) Runner block R1622 33. 20 with preload 0.13 C (C3)

Example:

Runner block SLS, Size 35

- a) Runner block R1623 31. 20 with Preload 0.02 C (C1)
- b) Runner block R1623 32. 20 with Preload 0.08 C (C2)
- c) Runner block R1623 33. with Preload 0.13 C (C3)

Graphic Legend

$\delta_{el.}$ = elastic deformation

F = Load

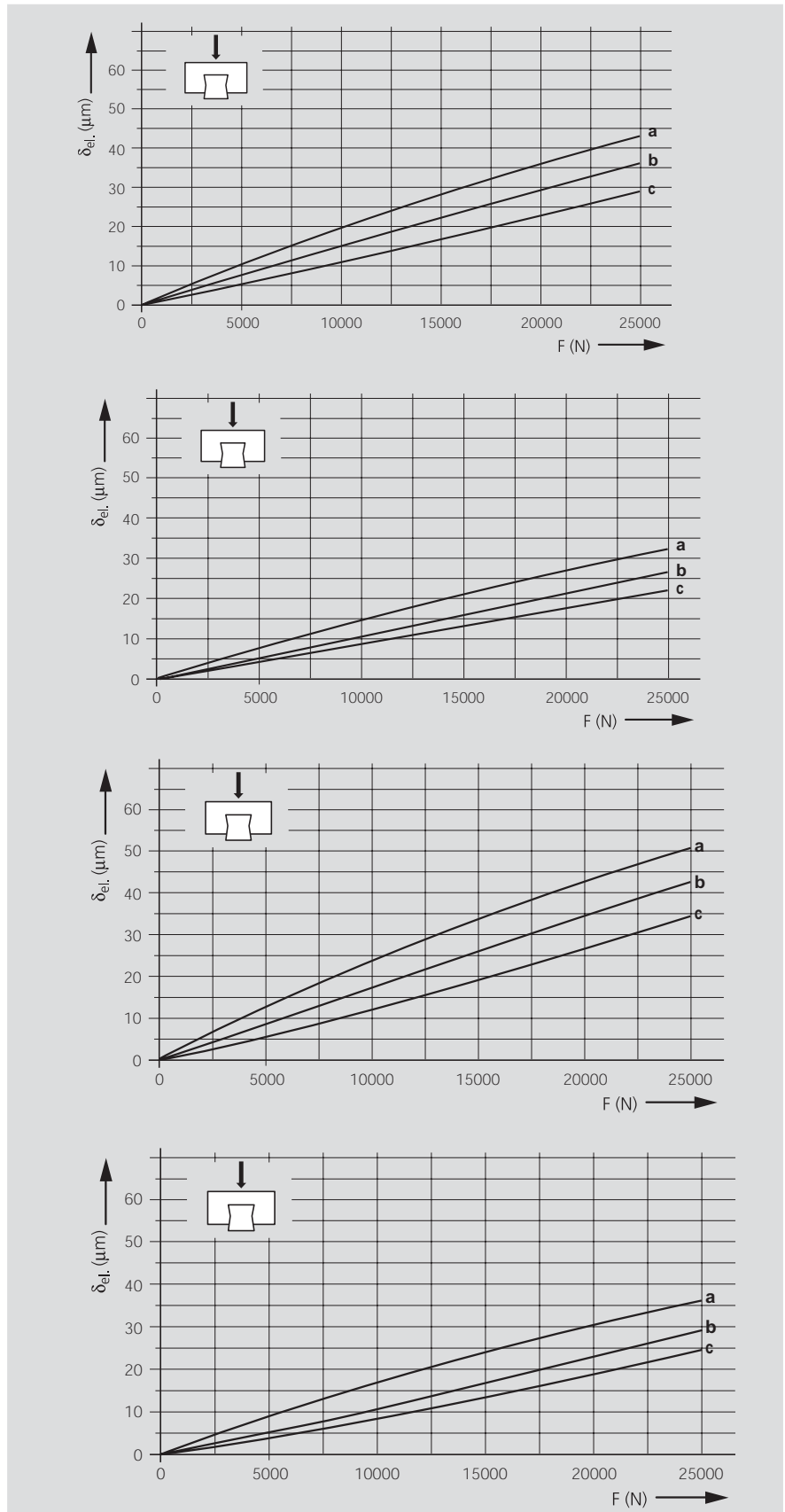

Standard Runner Blocks, Steel Version

Excellent properties:

- Top load capacities in all 4 main load directions
- Low noise level and outstanding running characteristics
- Excellent dynamic characteristics $v = 5 \text{ m/s}$; $a_{\text{max}} = 500 \text{ m/s}^2$
- Long-term lubrication, up to several years possible
- Minimum quantity lubrication system with integrated reservoir for oil lubrication
- Lube ports with metal threads on all sides
- Limitless interchangeability due to standardized guide rails, with or without rail seal cover strip, for all runner block versions
- Optimum system rigidity through preloaded O-arrangement
- Integrated, inductive and wear-free measuring system as an option
- Existing range of accessories fully utilizable
- Top logistics that are unique worldwide due to interchangeability of components within one accuracy class

Further highlights:

- Runner block can be bolted from above or below
- Improved rigidity under lift-off and side loading conditions when additional mounting screws are used in holes provided at the center of the runner block
- Front face securing threads for all attachments
- High rigidity in all load directions – can therefore be used in single bearing applications
- Integral, all-round sealing
- High torque load capacity
- Optimized entry-zone geometry and the high number of balls per track greatly reduce variation in elastic deflection
- Smooth, light running due to optimized ball recirculation and ideal ball/ball chain track geometry
- Various preload classes
- Available with surface protection as an option
- New: corrosion-resistant version of runner block complying with DIN EN 10088
- With ball chain as an option *

* depends on type

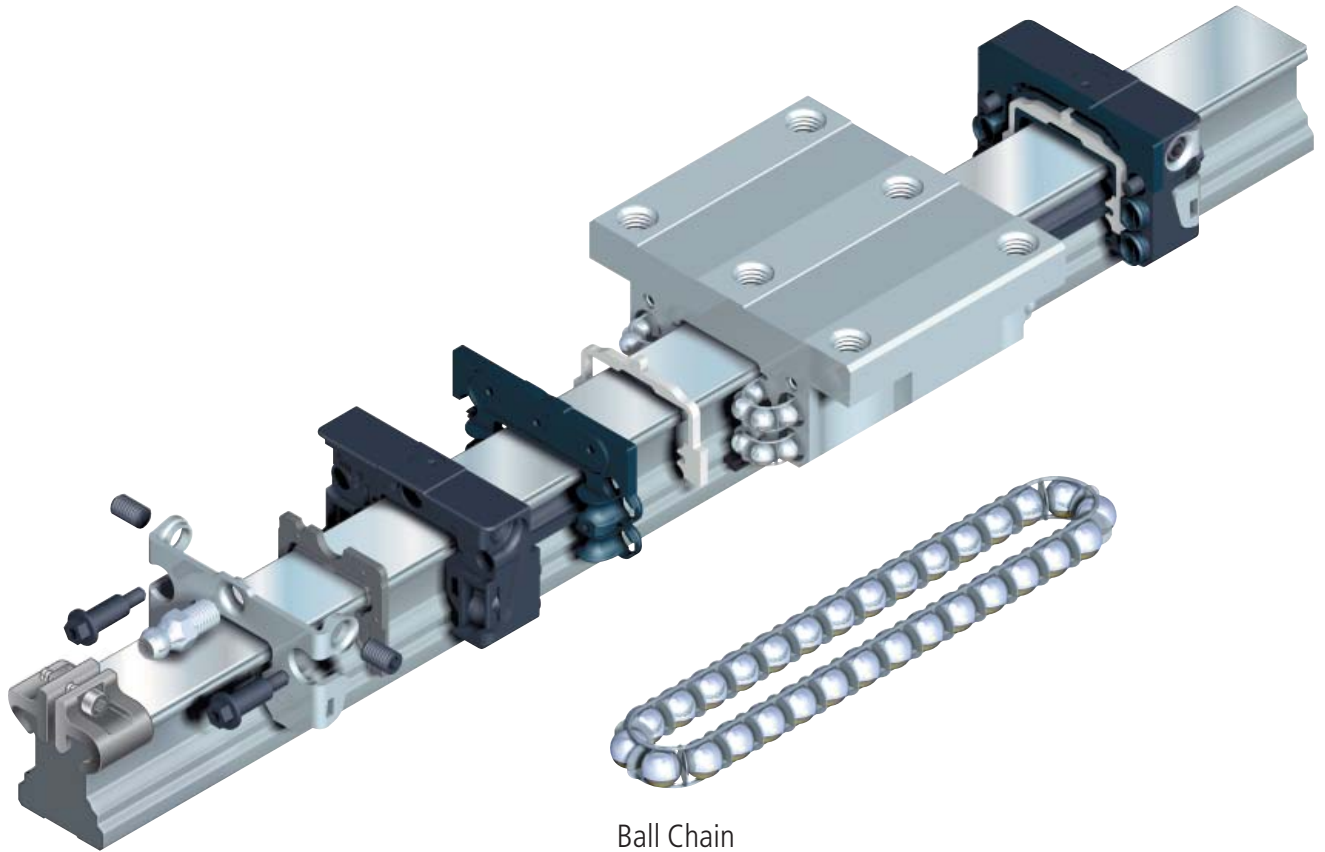

Ball Chain

– Optimized noise level and running characteristics

Material Specifications

- 1 Recirculation elements: POM
- 2 Lube nipple: carbonized steel
- 3 Thread plates: 1.4301
- 4 Seals: TEE-E
- 5 Flange screws: carbonized steel
- 6 Set screws: 1.4301
- 7 Balls: anti-friction bearing steel
- 8 Housing: heat-treated steel
- 9 Strip holder: aluminum
- 10 Clamping screw and nut: 1.4301
- 11 Guide rail: heat-treated steel
- 12 Rail seal cover strip: 1.4310

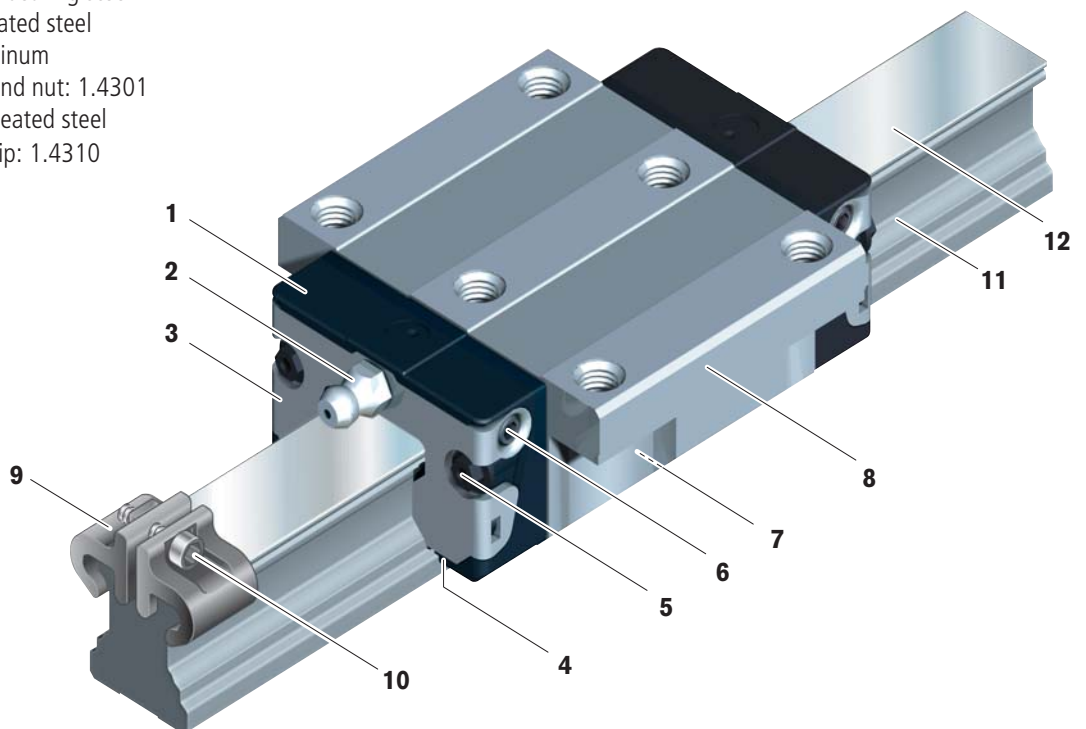

Runner Blocks, Steel

Runner Block FNS R1651

Flange Standard

- Runner block without ball chain:
See table for part numbers
- Runner block with low friction seal without ball chain**:
Part numbers R1651 xxx 21
- Runner block with ball chain:
Part numbers R1651 xxx 22
- Runner block with low friction seal and ball chain**:
Part numbers R1651 xxx 23

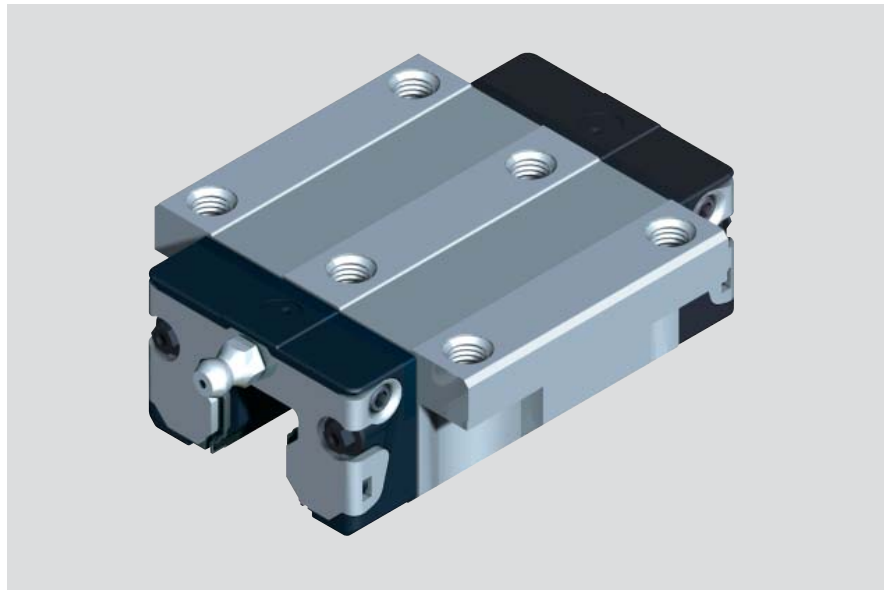

Dynamic Characteristics

Speed $v_{max} = 5 \text{ m/s}$
 Acceleration $a_{max} = 500 \text{ m/s}^2$

Precision Runner Blocks

- Pre-lubricated

Corrosion resistant versions

For Resist NR with runner block out of corrosion resistant steel, see appropriate section.

For Resist NR II all corrosion resistant steel parts see appropriate section.

High Precision Runner Blocks

- Improved travel accuracy
- Superior quality
- Highest precision
- Pre-lubricated
- Minimal oil preservation

Preload Class

- C0 = without Preload
- C1 = Preload 2% C
- C2 = Preload 8% C
- C3 = Preload 13% C

For further technical information, please see chapter on "General Technical Data and Calculations".

Size	Accuracy Class	Part numbers for runner blocks for preload class		
		C0	C1	C2
15	N	R1651 194 20	R1651 114 20	R1651 124 20
	H	R1651 193 20	R1651 113 20	R1651 123 20
	P		R1651 112 20	R1651 122 20
20	N	R1651 894 20	R1651 814 20	R1651 824 20
	H	R1651 893 20	R1651 813 20	R1651 823 20
	P		R1651 812 20	R1651 822 20
25	N	R1651 294 20	R1651 214 20	R1651 224 20
	H	R1651 293 20	R1651 213 20	R1651 223 20
	P		R1651 212 20	R1651 222 20
30	N	R1651 794 20	R1651 714 20	R1651 724 20
	H	R1651 793 20	R1651 713 20	R1651 723 20
	P		R1651 712 20	R1651 722 20
35	N	R1651 394 20	R1651 314 20	R1651 324 20
	H	R1651 393 20	R1651 313 20	R1651 323 20
	P		R1651 312 20	R1651 322 20
45*	N	R1651 494 20	R1651 414 20	R1651 424 20
	H	R1651 493 20	R1651 413 20	R1651 423 20
	P		R1651 412 20	R1651 422 20

Size	Accuracy Class	Part numbers for runner blocks for preload class		
		C1	C2	C3
15	XP	R1651 118 20	R1651 128 20	R1651 138 20
	SP	R1651 111 20	R1651 121 20	R1651 131 20
	UP	R1651 119 20	R1651 129 20	R1651 139 20
20	XP	R1651 818 20	R1651 828 20	R1651 838 20
	SP	R1651 811 20	R1651 821 20	R1651 831 20
	UP	R1651 819 20	R1651 829 20	R1651 839 20
25	XP	R1651 218 20	R1651 228 20	R1651 238 20
	SP	R1651 211 20	R1651 221 20	R1651 231 20
	UP	R1651 219 20	R1651 229 20	R1651 239 20
30	XP	R1651 718 20	R1651 728 20	R1651 738 20
	SP	R1651 711 20	R1651 721 20	R1651 731 20
	UP	R1651 719 20	R1651 729 20	R1651 739 20
35	XP	R1651 318 20	R1651 328 20	R1651 338 20
	SP	R1651 311 20	R1651 321 20	R1651 331 20
	UP	R1651 319 20	R1651 329 20	R1651 339 20
45*	XP	R1651 418 20	R1651 428 20	R1651 438 20
	SP	R1651 411 20	R1651 421 20	R1651 431 20
	UP	R1651 419 20	R1651 429 20	R1651 439 20

* No delivery with low friction seal

** Low friction seal available in preloads C0 and C1 (only for precision classes N, H, XP)

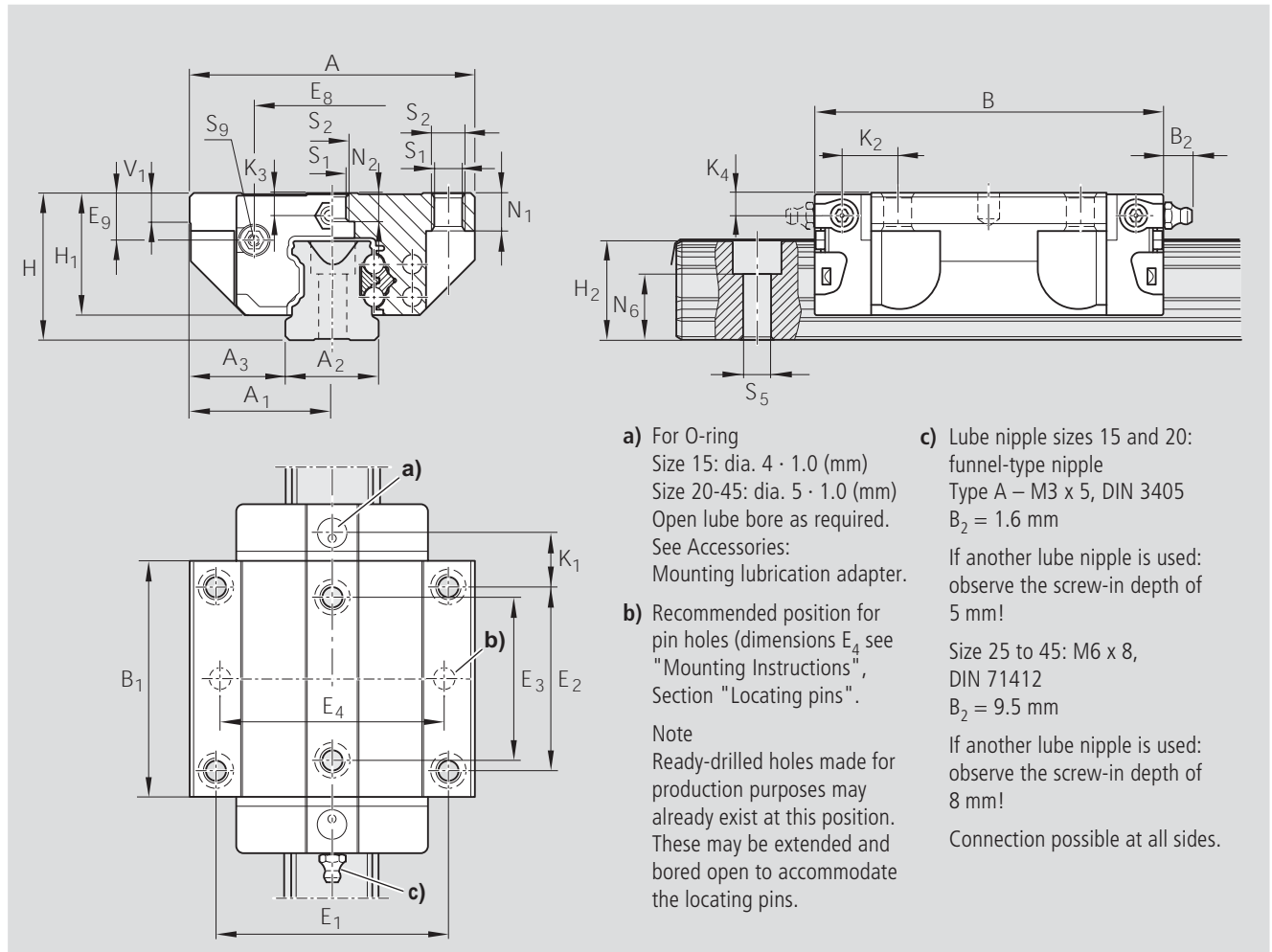

- a) For O-ring
 Size 15: dia. 4 · 1.0 (mm)
 Size 20-45: dia. 5 · 1.0 (mm)
 Open lube bore as required.
 See Accessories:
 Mounting lubrication adapter.
- b) Recommended position for pin holes (dimensions E₄ see "Mounting Instructions", Section "Locating pins").
 Note
 Ready-drilled holes made for production purposes may already exist at this position. These may be extended and bored open to accommodate the locating pins.
- c) Lube nipple sizes 15 and 20: funnel-type nipple
 Type A – M3 x 5, DIN 3405
 B₂ = 1.6 mm
 If another lube nipple is used: observe the screw-in depth of 5 mm!
 Size 25 to 45: M6 x 8, DIN 71412
 B₂ = 9.5 mm
 If another lube nipple is used: observe the screw-in depth of 8 mm!
 Connection possible at all sides.

Dimensions (mm)																				
Size	A	A ₁	A ₂	A ₃	B	B ₁	H	H ₁	H ₂ ¹⁾	H ₂ ²⁾	V ₁	E ₁	E ₂	E ₃	E ₈	E ₉	K ₁	K ₂	K ₃	K ₄
15	47	23.5	15	16.0	58.2	39.2	24	19.90	16.30	16.20	5.0	38	30	26	24.55	6.70	8.00	9.6	3.20	3.20
20	63	31.5	20	21.5	75.0	49.6	30	25.35	20.75	20.55	6.0	53	40	35	32.50	7.30	11.80	11.8	3.35	3.35
25	70	35.0	23	23.5	86.2	57.8	36	29.90	24.45	24.25	7.5	57	45	40	38.30	11.50	12.45	13.6	5.50	5.50
30	90	45.0	28	31.0	97.7	67.4	42	35.35	28.55	28.35	7.0	72	52	44	48.40	14.60	14.00	15.7	6.05	6.05
35	100	50.0	34	33.0	110.5	77.0	48	40.40	32.15	31.85	8.0	82	62	52	58.00	17.35	14.50	16.0	6.90	6.90
45	120	60.0	45	37.5	137.6	97.0	60	50.30	40.15	39.85	10.0	100	80	60	69.80	20.90	17.30	19.3	8.20	8.20

¹⁾ Dimension H₂ with rail seal cover strip

²⁾ Dimension H₂ without rail seal cover strip

Size	Dimensions (mm)								Mass (kg)	Load capacities (N) ³⁾		Moments (Nm)			
	N ₁	N ₂	N ₆ ^{±0.5}	S ₁	S ₂	S ₅	S ₉	C dyn.		C ₀ stat.	M _t dyn.	M _{t0} stat.	M _L dyn.	M _{L0} stat.	
15	5.2	4.4	10.3	4.3	M5	4.4	M2.5-3.5 deep	0.20	7 800	13 500	130	74	40	71	
20	7.7	5.2	13.2	5.3	M6	6.0	M3-5 deep	0.45	18 800	24 400	240	310	130	165	
25	9.3	7.0	15.2	6.7	M8	7.0	M3-5 deep	0.65	22 800	30 400	320	430	180	240	
30	11.0	7.9	17.0	8.5	M10	9.0	M3-5 deep	1.10	31 700	41 300	540	720	290	380	
35	12.0	10.2	20.5	8.5	M10	9.0	M3-5 deep	1.60	41 900	54 000	890	1160	440	565	
45	15.0	14.4	23.5	10.4	M12	14.0	M4-7 deep	3.00	68 100	85 700	1830	2310	890	1130	

³⁾ Load capacities for version without ball chain. Load capacities for version without ball chain, see Product Overview with Load Capacities. Determination of the dynamic of the load capacities and moments is based on 100,000 m of stroke travel. Often only 50,000 m are actually stipulated. Comparison: Value C, M_t and M_L per table multiplied by 1.26.

Standard Runner Blocks, Steel

Runner Block FNS R1651

Flange Standard

– Runner block without ball chain:
See table for part numbers

Dynamic Characteristics

Speed $v_{max} = 3 \text{ m/s}$
Acceleration $a_{max} = 250 \text{ m/s}^2$

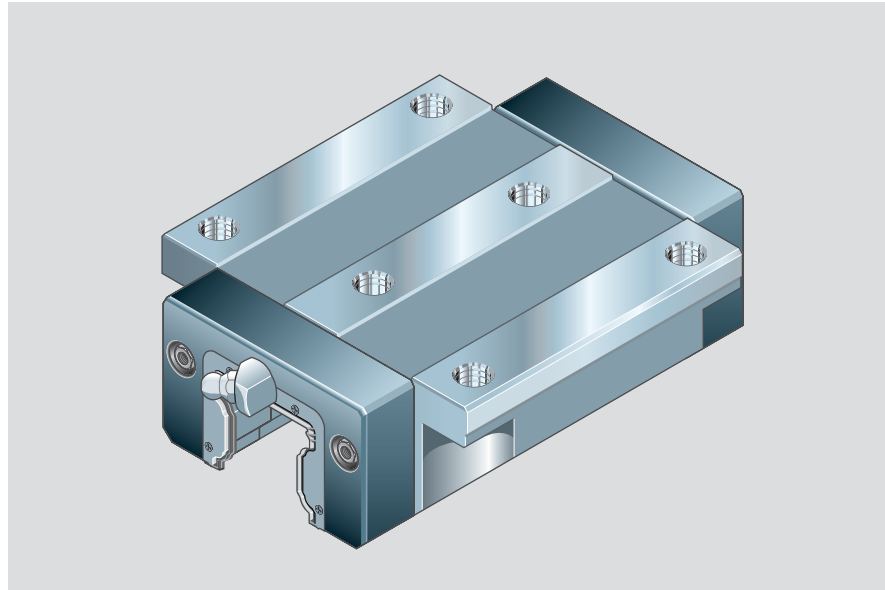

Precision Runner Blocks

– Not Pre-lubricated

Size	Accuracy Class	Part numbers for runner blocks for preload class			
		C0	C1	C2	C3
55	N	R1651 594 10	R1651 514 10	R1651 524 10	
	H	R1651 593 10	R1651 513 10	R1651 523 10	
	P		R1651 512 10	R1651 522 10	R1651 532 10
65	N	R1651 694 10	R1651 614 10	R1651 624 10	
	H	R1651 693 10	R1651 613 10	R1651 623 10	
	P		R1651 612 10	R1651 622 10	R1651 632 10

Size	Accuracy Class	Part numbers for runner blocks for preload class			
		C0	C1	C2	C3
55	SP		R1651 511 10	R1651 521 10	R1651 531 10
	UP		R1651 519 10	R1651 529 10	R1651 539 10
65	SP		R1651 611 10	R1651 621 10	R1651 631 10
	UP		R1651 619 10	R1651 629 10	R1651 639 10

Corrosion resistant versions

Resist CR – Runner block housing chromium-plated matt silver

– Not Pre-lubricated

Size	Accuracy Class	Part numbers for runner blocks for preload class	
		C0	C1
55	H	R1651 593 60	R1651 513 60
65	H	R1651 693 60	R1651 613 60

Preload Class

C0 = without Preload

C1 = Preload 2% C

C2 = Preload 8% C

C3 = Preload 13% C

For further technical information, please see chapter on "General Technical Data and Calculations".

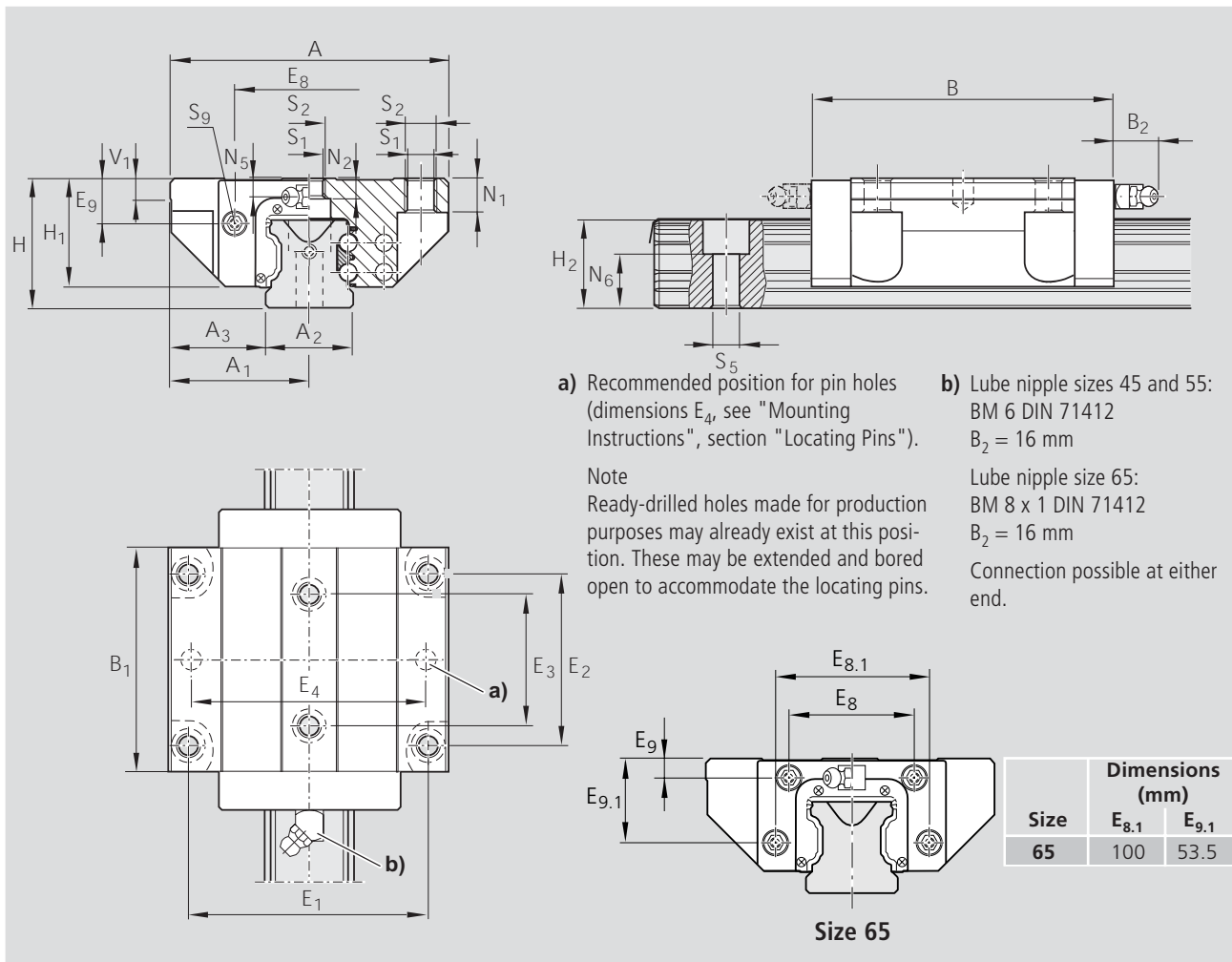

Size	Dimensions (mm)																	
	A	A_1	A_2	A_3	B	B_1	H	H_1	$H_2^{1)}$	$H_2^{2)}$	V_1	E_1	E_2	E_3	E_8	E_9	N_1	N_2
45*	120	60.0	45	37.5	133	97.0	60	50.0	40.15	39.85	10.0	100	80	60	69.8	20.9	15.0	12.4
55	140	70.0	53	43.5	159	115.5	70	57.0	48.15	47.85	12.0	116	95	70	80.0	22.3	18.0	13.5
65	170	85.0	63	53.5	188	139.6	90	76.0	60.15	59.85	15.0	142	110	82	76.0	11.0	23.0	14.0

1) Dimension H_2 with rail seal cover strip

2) Dimension H_2 without rail seal cover strip

Size	Dimensions (mm)							Mass (kg)	Load capacities (N) ³⁾		Moments (Nm)			
	N_5	$N_6^{\pm 0.5}$	S_1	S_2	S_5	S_9	C dyn.		C_0 stat.	M_t dyn.	M_{t0} stat.	M_L dyn.	M_{L0} stat.	
45*	8.0	23.5	10.5	M12	14.0	M4-7 deep	2.90	68 100	85 700	1 830	2 310	890	1 130	
55	9.0	29.0	12.5	M14	16.0	M5-8 deep	5.20	98 200	121 400	3 100	3 860	1 540	1 905	
65	16.0	38.5	14.5	M16	18.0	M4-7 deep	10.25	123 000	192 700	4 850	7 610	2 430	3 815	

3) Load capacities for version without ball chain. Load capacities for version without ball chain, see Product Overview with Load Capacities. Determination of the dynamic of the load capacities and moments is based on 100,000 m of stroke travel. Often only 50,000 m are actually stipulated. Comparison: Value C, M_t und M_L per table multiplied by 1.26.

Runner Blocks, Corrosion-resistant Steel - Resist NR¹⁾

Runner Block FNS R2001

Flange Standard

- Runner block without ball chain:
See table for part numbers
- Runner block with low friction seal without ball chain:
Part numbers R2001 xxx 31
- Runner block with ball chain:
Part numbers R2001 xxx 32
- Runner block with low friction seal and ball chain:
Part numbers R2001 xxx 33

Dynamic Characteristics

Speed $v_{\max} = 5 \text{ m/s}$
Acceleration $a_{\max} = 500 \text{ m/s}^2$

Corrosion resistant Custom version

- Pre-lubricated

Resist CR – Chromium-plated matt silver runner block housing instead of corrosion-resistant steel runner block housing

Resist CR without ball chain R1651 xxx 70

Resist CR with low friction seal, without ball chain R1651 xxx 71

Resist CR with ball chain R1651 xxx 72

Resist CR with low friction seal and ball chain R1651 xxx 73

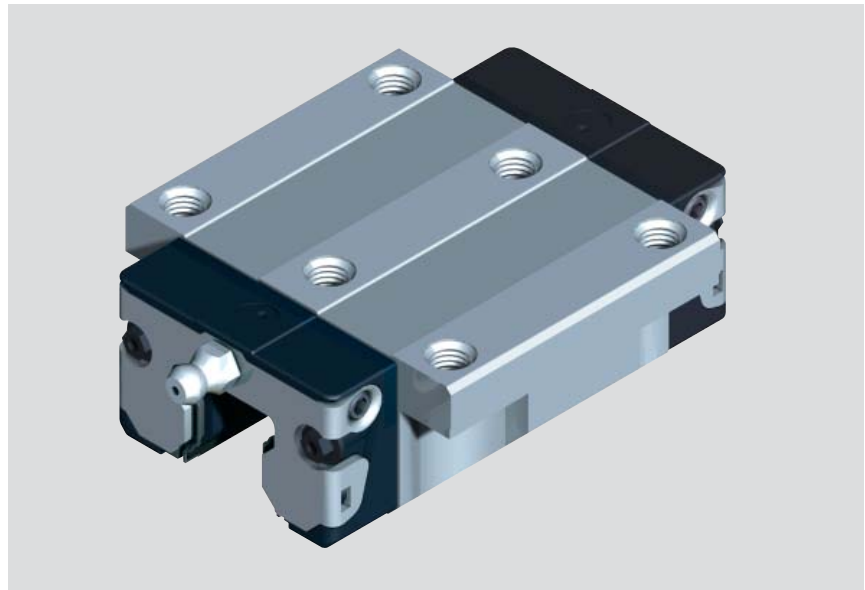

Size	Accuracy Class	Part numbers for runner blocks for preload class	
		C0	C1
15	H	R2001 193 30	
20	H	R2001 893 30	
25	H	R2001 293 30	
30	H	R2001 793 30	R2001 713 30
35	H	R2001 393 30	R2001 313 30
45 ²⁾	H	(R1651 493 70)	(R1651 413 70)

1) In preparation

2) Only available in chromium plated matt silver Resist CR at this time, no delivery on the low friction seal option

Preload Class

C0 = without Preload

C1 = Preload 2% C

For further technical information, please see chapter on "General Technical Data and Calculations".

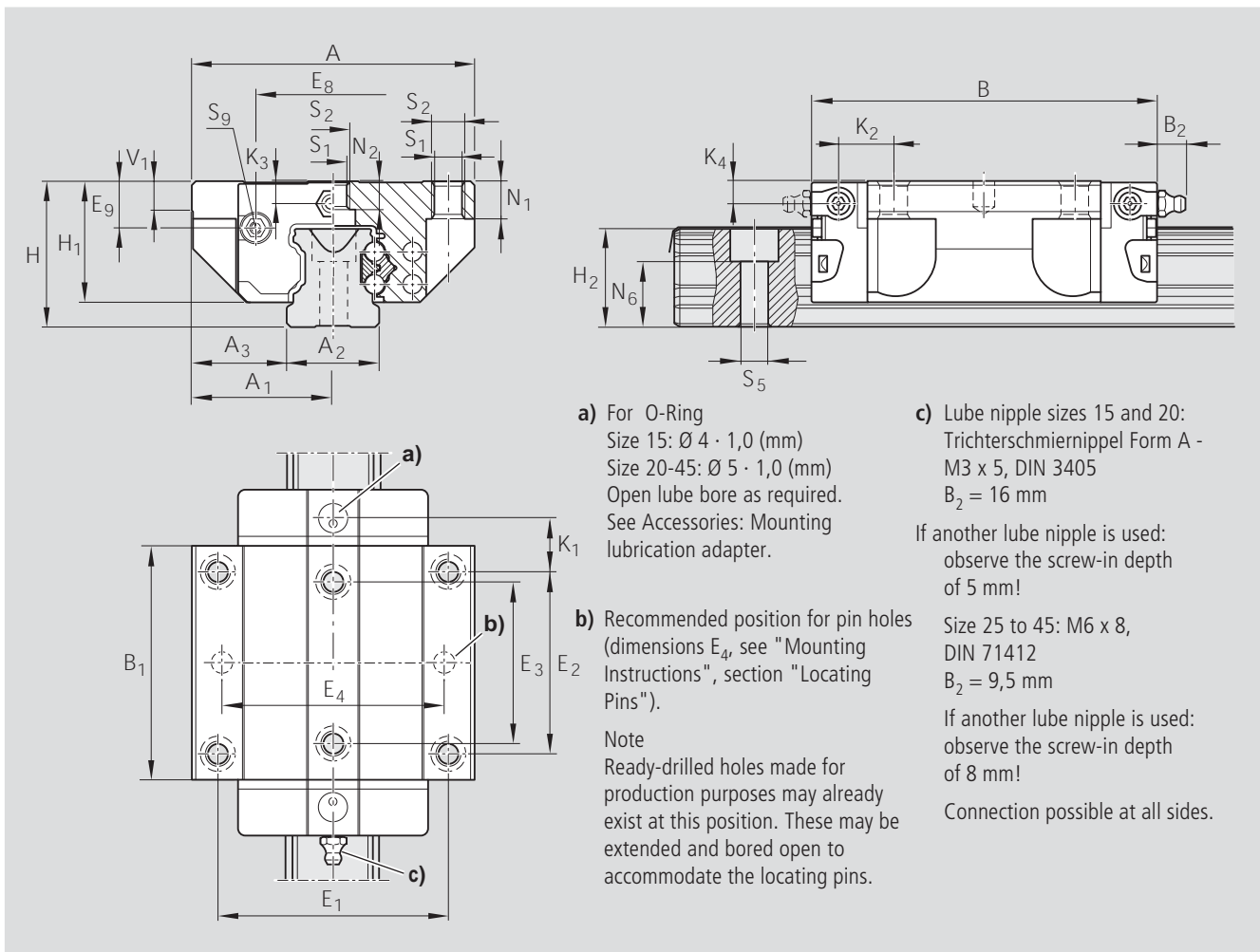

Dimensions (mm)																				
Size	A	A ₁	A ₂	A ₃	B	B ₁	H	H ₁	H ₂ ¹⁾	H ₂ ²⁾	V ₁	E ₁	E ₂	E ₃	E ₈	E ₉	K ₁	K ₂	K ₃	K ₄
15	47	23.5	15	16.0	58.2	39.2	24	19.90	16.30	16.20	5.0	38	30	26	24.55	6.70	8.00	9.6	3.20	3.20
20	63	31.5	20	21.5	75.0	49.6	30	25.35	20.75	20.55	6.0	53	40	35	32.50	7.30	11.80	11.8	3.35	3.35
25	70	35.0	23	23.5	86.2	57.8	36	29.90	24.45	24.25	7.5	57	45	40	38.30	11.50	12.45	13.6	5.50	5.50
30	90	45.0	28	31.0	97.7	67.4	42	35.35	28.55	28.35	7.0	72	52	44	48.40	14.60	14.00	15.7	6.05	6.05
35	100	50.0	34	33.0	110.5	77.0	48	40.40	32.15	31.85	8.0	82	62	52	58.00	17.35	14.50	16.0	6.90	6.90
45	120	60.0	45	37.5	137.6	97.0	60	50.30	40.15	39.85	10.0	100	80	60	69.80	20.90	17.30	19.3	8.20	8.20

¹⁾ Dimension H₂ with rail seal cover strip

²⁾ Dimension H₂ without rail seal cover strip

Size	Dimensions (mm)								Load Capacities (N) ³⁾		Moments (Nm)			
	N ₁	N ₂	N ₆ ^{±0,5}	S ₁	S ₂	S ₅	S ₉	Mass (kg)	C dyn.	C ₀ stat.	M _t dyn.	M _{t0} stat.	M _L dyn.	M _{L0} stat.
	15	5.2	4.4	10.3	4.3	M5	4.4	M2.5-3.5deep	0.20	7 800	13 500	74	130	40
20	7.7	5.2	13.2	5.3	M6	6.0	M3-5deep	0.45	18 800	24 400	240	310	130	165
25	9.3	7.0	15.2	6.7	M8	7.0	M3-5deep	0.65	22 800	30 400	320	430	180	240
30	11.0	7.9	17.0	8.5	M10	9.0	M3-5deep	1.10	31 700	41 300	540	720	290	380
35	12.0	10.2	20.5	8.5	M10	9.0	M3-5deep	1.60	41 900	54 000	890	1 160	440	565
45	15.0	14.4	23.5	10.4	M12	14.0	M4-7deep	3.00	68 100	85 700	1830	2310	890	1130

³⁾ Load capacities for version without ball chain. Load capacities for version without ball chain, see Product Overview with Load Capacities. Determination of the dynamic of the load capacities and moments is based on 100,000 m of stroke travel. Often only 50,000 m are actually stipulated. Comparison: Value C, M_t und M_L per table multiplied by 1.26.

Standard Runner Blocks, Steel Version

Runner Block FLS R1653

Flange Long

- Runner block without ball chain:
See table for part numbers
- Runner block with low friction seal without ball chain**:
Part numbers R1653 xxx 21
- Runner block with ball chain:
Part numbers R1653 xxx 22
- Runner block with low friction seal and ball chain**:
Part numbers R1653 xxx 23

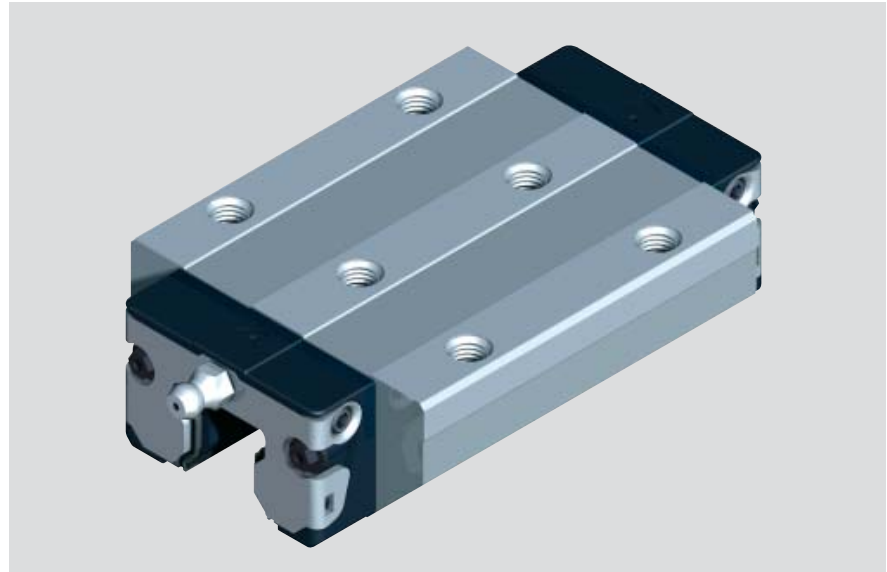

Dynamic Characteristics

Speed $v_{max} = 3 \text{ m/s}$
 Acceleration $a_{max} = 500 \text{ m/s}^2$

Precision Runner Block

- Pre-lubricated

Corrosion resistant versions

For Resist NR with runner block out of corrosion resistant steel, see appropriate section.

For Resist NR II all corrosion resistant steel parts see appropriate section.

Size	Accuracy Class	Part numbers for runner blocks for preload class		
		C0	C1	C2
15	N	R1653 194 20	R1653 114 20	R1653 124 20
	H	R1653 193 20	R1653 113 20	R1653 123 20
	P		R1653 112 20	R1653 122 20
20	N	R1653 894 20	R1653 814 20	R1653 824 20
	H	R1653 893 20	R1653 813 20	R1653 823 20
	P		R1653 812 20	R1653 822 20
25	N	R1653 294 20	R1653 214 20	R1653 224 20
	H	R1653 293 20	R1653 213 20	R1653 223 20
	P		R1653 212 20	R1653 222 20
30	N	R1653 794 20	R1653 714 20	R1653 724 20
	H	R1653 793 20	R1653 713 20	R1653 723 20
	P		R1653 712 20	R1653 722 20
35	N	R1653 394 20	R1653 314 20	R1653 324 20
	H	R1653 393 20	R1653 313 20	R1653 323 20
	P		R1653 312 20	R1653 322 20
45*	N	R1653 494 20	R1653 414 20	R1653 424 20
	H	R1653 493 20	R1653 413 20	R1653 423 20
	P		R1653 412 20	R1653 422 20

High Precision Runner Blocks

- Improved travel accuracy
- Superior quality
- Highest precision
- Pre-lubricated
- Minimal oil preservation

Preload Class

C0 = without Preload

C1 = Preload 2% C

C2 = Preload 8% C

C3 = Preload 13% C

For further technical information, please see chapter on "General Technical Data and Calculations".

Size	Accuracy Class	Part numbers for runner blocks for preload class		
		C1	C2	C3
15	XP	R1653 118 20	R1653 128 20	R1653138 20
	SP	R1653 111 20	R1653 121 20	R1653131 20
	UP	R1653 119 20	R1653 129 20	R1653139 20
20	XP	R1653 818 20	R1653 828 20	R1653838 20
	SP	R1653 811 20	R1653 821 20	R1653831 20
	UP	R1653 819 20	R1653 829 20	R1653839 20
25	XP	R1653 218 20	R1653 228 20	R1653238 20
	SP	R1653 211 20	R1653 221 20	R1653231 20
	UP	R1653 219 20	R1653 229 20	R1653239 20
30	XP	R1653 718 20	R1653 728 20	R1653738 20
	SP	R1653 711 20	R1653 721 20	R1653731 20
	UP	R1653 719 20	R1653 729 20	R1653739 20
35	XP	R1653 318 20	R1653 328 20	R1653338 20
	SP	R1653 311 20	R1653 321 20	R1653331 20
	UP	R1653 319 20	R1653 329 20	R1653339 20
45*	XP	R1653 418 20	R1653 428 20	R1653438 20
	SP	R1653 411 20	R1653 421 20	R1653431 20
	UP	R1653 419 20	R1653 429 20	R1653439 20

* No delivery with low friction seal

** Delivery of low friction seal in preloads for C0 and C1 (only for precision classes N, H, XP)

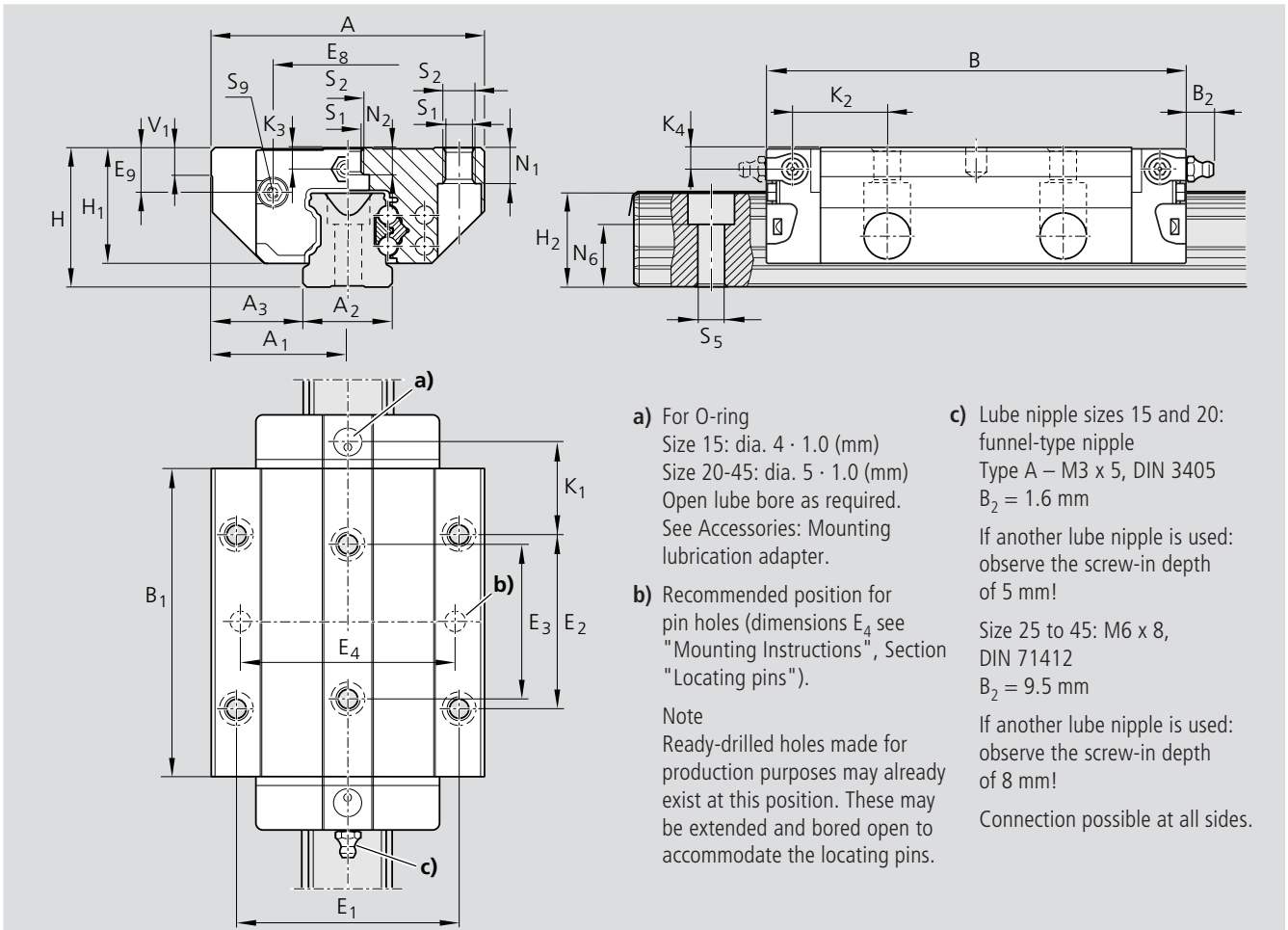

- a) For O-ring
 Size 15: dia. 4 · 1.0 (mm)
 Size 20-45: dia. 5 · 1.0 (mm)
 Open lube bore as required.
 See Accessories: Mounting lubrication adapter.
- b) Recommended position for pin holes (dimensions E₄ see "Mounting Instructions", Section "Locating pins").
 Note
 Ready-drilled holes made for production purposes may already exist at this position. These may be extended and bored open to accommodate the locating pins.
- c) Lube nipple sizes 15 and 20: funnel-type nipple
 Type A – M3 x 5, DIN 3405
 B₂ = 1.6 mm
 If another lube nipple is used: observe the screw-in depth of 5 mm!
 Size 25 to 45: M6 x 8, DIN 71412
 B₂ = 9.5 mm
 If another lube nipple is used: observe the screw-in depth of 8 mm!
 Connection possible at all sides.

Dimensions (mm)																				
Size	A	A ₁	A ₂	A ₃	B	B ₁	H	H ₁	H ₂ ¹⁾	H ₂ ²⁾	V ₁	E ₁	E ₂	E ₃	E ₈	E ₉	K ₁	K ₂	K ₃	K ₄
15	47	23.5	15	16.0	72.6	53.6	24	19.90	16.30	16.20	5.0	38	30	26	24.55	6.70	15.20	16.80	3.20	3.20
20	63	31.5	20	21.5	91.0	65.6	30	25.35	20.75	20.55	6.0	53	40	35	32.50	7.30	19.80	19.80	3.35	3.35
25	70	35.0	23	23.5	107.9	79.5	36	29.90	24.45	24.25	7.5	57	45	40	38.30	11.50	23.30	24.45	5.50	5.50
30	90	45.0	28	31.0	119.7	89.4	42	35.35	28.55	28.35	7.0	72	52	44	48.40	14.60	25.00	26.70	6.05	6.05
35	100	50.0	34	33.0	139.0	105.5	48	40.40	32.15	31.85	8.0	82	62	52	58.00	17.35	28.75	30.25	6.90	6.90
45	120	60.0	45	37.5	174.1	133.5	60	50.30	40.15	39.85	10.0	100	80	60	69.80	20.90	35.50	37.50	8.20	8.20

¹⁾ Dimension H₂ with rail seal cover strip ²⁾ Dimension H₂ without rail seal cover strip

Size	Dimensions (mm)							Mass (kg)	Load Capacities (N ³⁾		Moments (Nm)			
	N ₁	N ₂	N ₆ ^{±0.5}	S ₁	S ₂	S ₅	S ₉		C dyn.	C ₀ stat.	M _t dyn.	M _{t0} stat.	M _L dyn.	M _{L0} stat.
15	5.2	4.4	10.3	4.3	M5	4.4	M2.5-3.5tief	0.30	10 000	20 200	130	190	98	150
20	7.7	5.2	13.2	5.3	M6	6.0	M3-5tief	0.55	24 400	35 200	310	450	225	330
25	9.3	7.0	15.2	6.7	M8	7.0	M3-5tief	0.90	30 400	45 500	430	650	345	510
30	11.0	7.9	17.0	8.5	M10	9.0	M3-5tief	1.50	40 000	57 800	690	1 000	495	715
35	12.0	10.2	20.5	8.5	M10	9.0	M3-5tief	2.25	55 600	81 000	1 200	1 740	830	1 215
45	15.0	12.4	23.5	10.4	M12	14.0	M4-7tief	4.30	90 400	128 500	2 440	3 470	1700	2425

³⁾ Load capacities for version without ball chain. Load capacities for version without ball chain, see Product Overview with Load Capacities. Determination of the dynamic of the load capacities and moments is based on 100,000 m of stroke travel. Often only 50,000 m are actually stipulated. Comparison: Value C, M_t and M_L per table multiplied by 1.26.

Standard Runner Blocks, Steel Version

Runner Block FLS R1653

Flange Long

- Runner block without ball chain:
See table for part numbers

Dynamic Characteristics

Speed $v_{max} = 5 \text{ m/s}$
 Acceleration $a_{max} = 250 \text{ m/s}^2$

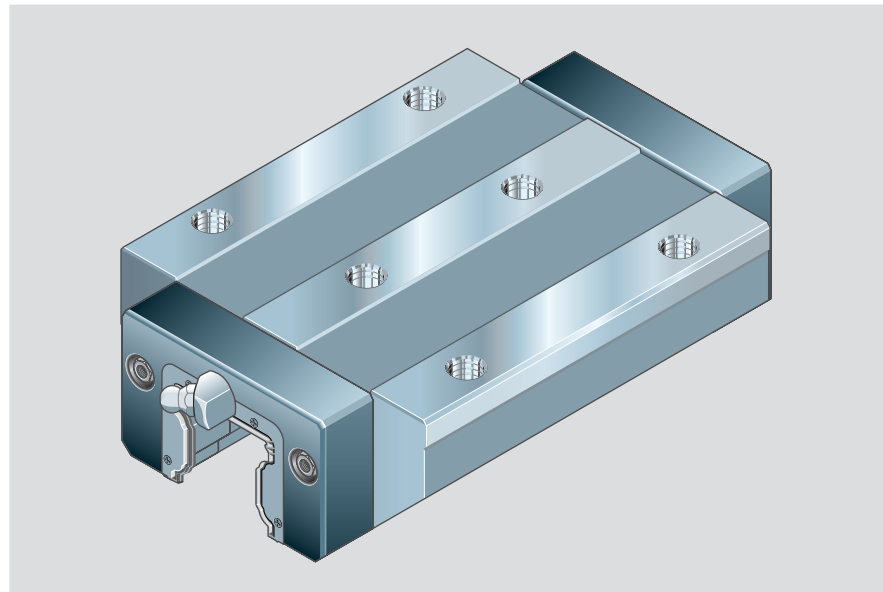

Precision Runner Blocks

- Not Pre-lubricated

Size	Accuracy Class	Part numbers for runner blocks for preload class			
		C0	C1	C2	C3
55	N	R1653 594 10	R1653 514 10	R1653 524 10	
	H	R1653 593 10	R1653 513 10	R1653 523 10	
	P		R1653 512 10	R1653 522 10	R1653 532 10
65	N	R1653 694 10	R1653 614 10	R1653 624 10	
	H	R1653 693 10	R1653 613 10	R1653 623 10	
	P		R1653 612 10	R1653 622 10	R1653 632 10

Size	Accuracy Class	Part numbers for runner blocks for preload class		
		C1	C2	C3
55	SP	R1653 511 10	R1653 521 10	R1653 531 10
	UP	R1653 519 10	R1653 529 10	R1653 539 10
65	SP	R1653 611 10	R1653 621 10	R1653 631 10
	UP	R1653 619 10	R1653 629 10	R1653 639 10

Corrosion resistant versions

Resist CR – Runner block housing chromium-plated matt silver

- Not Pre-lubricated

Size	Accuracy Class	Part numbers for runner blocks for preload class	
		C0	C1
55	H	R1653 593 60	R1653 513 60
65	H	R1653 693 60	R1653 613 60

Preload Class

- C0 = without Preload
- C1 = Preload 2% C
- C2 = Preload 8% C
- C3 = Preload 13% C

For further technical information, please see chapter on "General Technical Data and Calculations".

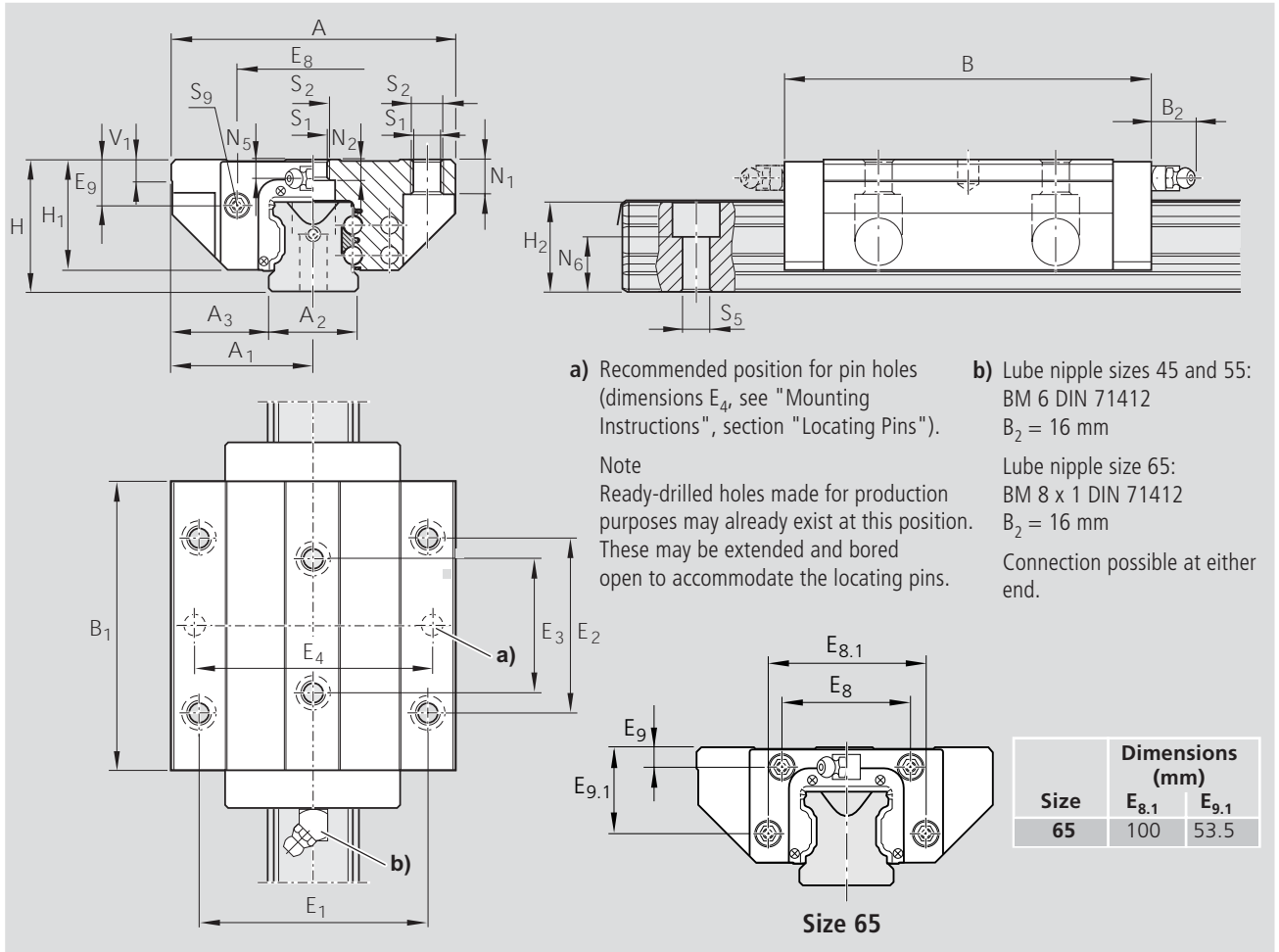

Size	Dimensions (mm)																	
	A	A_1	A_2	A_3	B	B_1	H	H_1	$H_2^{1)}$	$H_2^{2)}$	V_1	E_1	E_2	E_3	E_8	E_9	N_1	N_2
55	140	70.0	53	43.5	200.0	155.5	70	57.0	48.15	47.85	12.0	116	95	70	80.0	22.3	18.0	13.5
65	170	85.0	63	53.5	243.0	194.6	90	76.0	60.15	59.85	15.0	142	110	82	76.0	11.0	23.0	14.0

¹⁾ Dimension H_2 with rail seal cover strip

²⁾ Dimension H_2 without rail seal cover strip

Size	Dimensions (mm)						Mass (kg)	Load capacities (N ³⁾)				Moments (Nm)	
	N_5	$N_6^{\pm 0.5}$	S_1	S_2	S_5	S_9		C		M_t		M_L	
								dyn.	C_0 stat.	dyn.	stat.	dyn.	M_{L0} stat.
45	8.0	23.5	10.5	M12	14	M4-7 deep	4.20	90 400	128 500	2 440	3 470	1 700	2 425
55	9.0	29.0	12.5	M14	16	M5-8 deep	7.50	124 200	170 000	3 950	5 400	2 630	3 600
65	16.0	38.5	14.5	M16	18	M4-7 deep	14.15	163 000	289 000	6 440	11 420	4 620	8 190

³⁾ Load capacities for version without ball chain. Load capacities for version without ball chain, see Product Overview with Load Capacities. Determination of the dynamic of the load capacities and moments is based on 100,000 m of stroke travel. Often only 50,000 m are actually stipulated. Comparison: Value C, M_t and M_L per table multiplied by 1.26.

Runner Blocks, Corrosion-resistant Steel - Resist NR¹⁾

Runner Block FLS R2002

Flange Long

- Runner block without ball chain:
See table for part numbers
- Runner block with low friction seal without ball chain:
Part numbers R2002 xxx 31
- Runner block with ball chain:
Part numbers R2002 xxx 32
- Runner block with low friction seal and ball chain:
Part numbers R2002 xxx 33

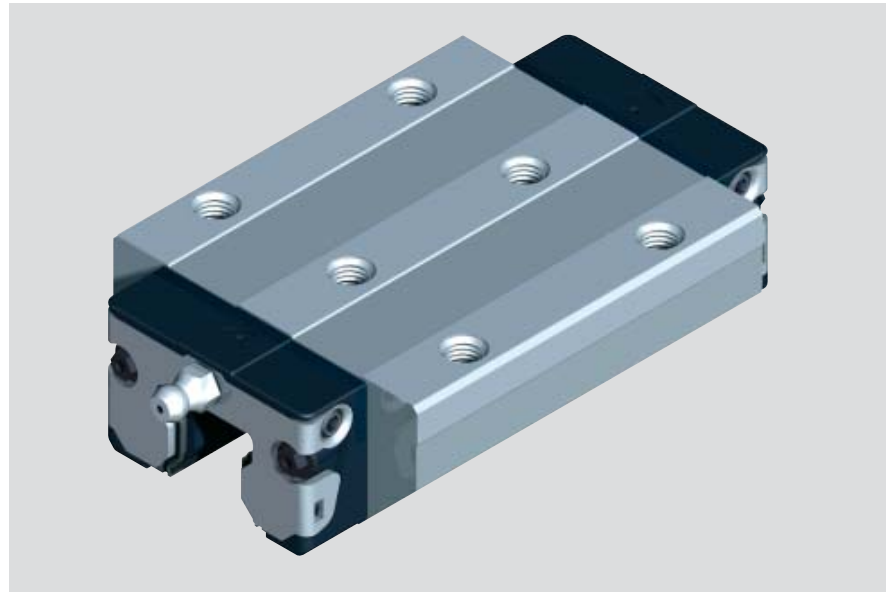

Dynamic Characteristics

Speed $v_{\max} = 5 \text{ m/s}$
 Acceleration $a_{\max} = 500 \text{ m/s}^2$

Precision Runner Blocks

- Pre-lubricated

Size	Accuracy Class	Part numbers for runner blocks for preload class	
		C0	C1
15	H	R2002 193 30	
20	H	R2002 893 30	
25	H	R2002 293 30	
30	H	R2002 793 30	R2002 713 30
35	H	R2002 393 30	R2002 313 30
45 ²⁾	H	(R1653 493 70)	(R1653 413 70)

1) In Preparation

2) Only available in chromium plated matt silver Resist CR at this time, no delivery of low friction seal option

Corrosion resistant Custom version

- Pre-lubricated

Resist CR – Chromium-plated matt silver runner block housing instead of corrosion-resistant steel runner block housing

Resist CR without ball chain R1653 xxx 70

Resist CR with low friction seal, without ball chain R1653 xxx 71

Resist CR with ball chain R1651 xxx 72

Resist CR with low friction seal and ball chain R1653 xxx 73

Preload Class

C0 = without Preload

C1 = Preload 2% C

For further technical information, please see chapter on "General Technical Data and Calculations".

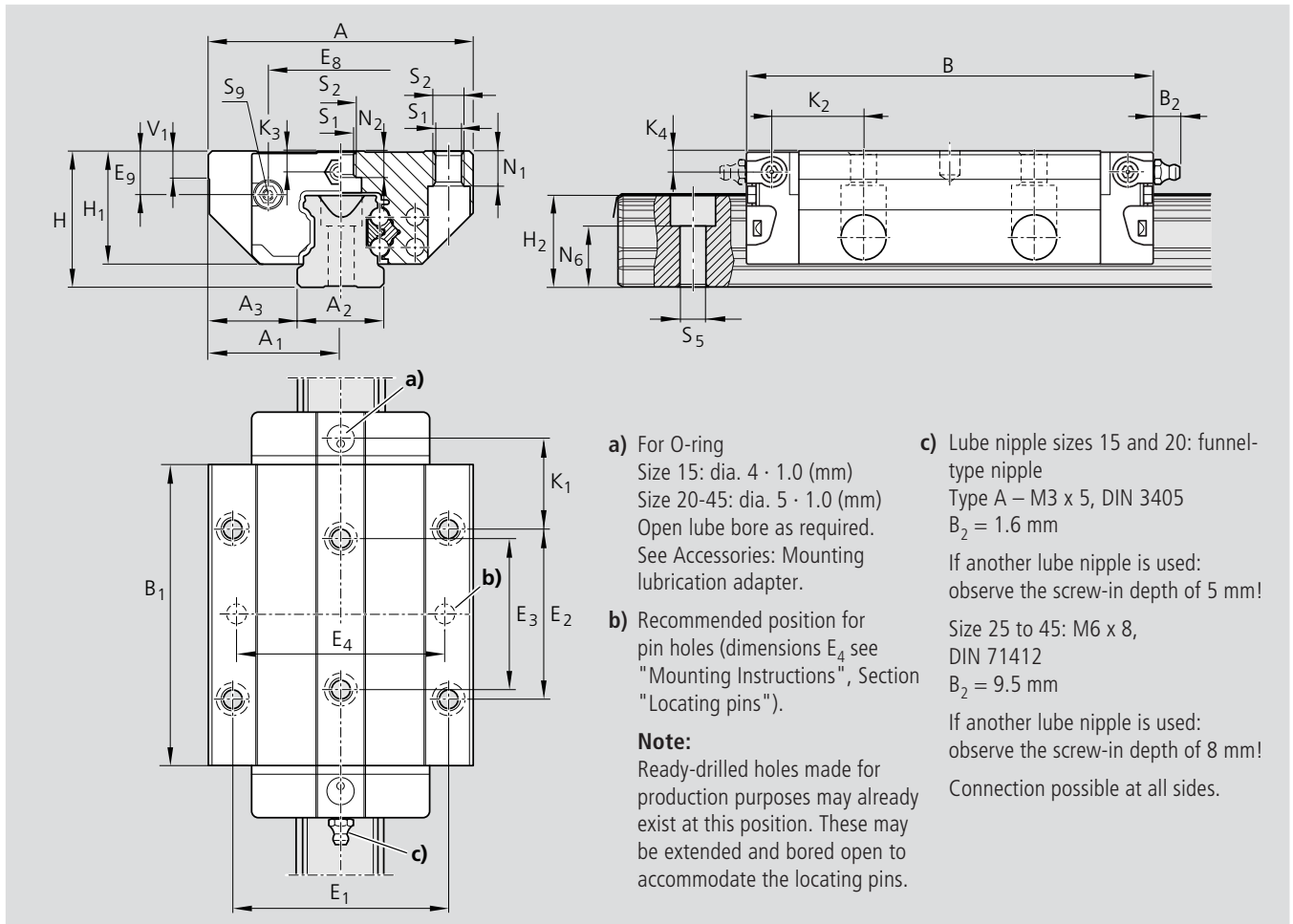

Dimensions (mm)																				
Size	A	A ₁	A ₂	A ₃	B	B ₁	H	H ₁	H ₂ ¹⁾	H ₂ ²⁾	V ₁	E ₁	E ₂	E ₃	E ₈	E ₉	K ₁	K ₂	K ₃	K ₄
15	47	23.5	15	16.0	72.6	53.6	24	19.90	16.30	16.20	5.0	38	30	26	24.55	6.70	15.20	16.80	3.20	3.20
20	63	31.5	20	21.5	91.0	65.6	30	25.35	20.75	20.55	6.0	53	40	35	32.50	7.30	19.80	19.80	3.35	3.35
25	70	35.0	23	23.5	107.9	79.5	36	29.90	24.45	24.25	7.5	57	45	40	38.30	11.50	23.30	24.45	5.50	5.50
30	90	45.0	28	31.0	119.7	89.4	42	35.35	28.55	28.35	7.0	72	52	44	48.40	14.60	25.00	26.70	6.05	6.05
35	100	50.0	34	33.0	139.0	105.5	48	40.40	32.15	31.85	8.0	82	62	52	58.00	17.35	28.75	30.25	6.90	6.90
45	120	60.0	45	37.5	174.1	133.5	60	50.30	40.15	39.85	10.0	100	80	60	69.80	20.90	35.50	37.50	8.20	8.20

¹⁾ Dimension H₂ with rail seal cover strip

²⁾ Dimension H₂ without rail seal cover strip

Size	Dimensions (mm)								Mass (kg)	Load Capacities (N) ³⁾				Moments (Nm)			
	N ₁	N ₂	N ₆ ^{±0.5}	S ₁	S ₂	S ₅	S ₉	C dyn.		C ₀ stat.	M _t dyn.	M _{t0} stat.	M _L dyn.	M _{L0} stat.			
15	5.2	4.4	10.3	4.3	M5	4.4	M2.5-3.5 deep	0.30	10 000	20 200	130	190	98	150			
20	7.7	5.2	13.2	5.3	M6	6.0	M3-5 deep	0.55	24 400	35 200	310	450	225	330			
25	9.3	7.0	15.2	6.7	M8	7.0	M3-5 deep	0.90	30 400	45 500	430	650	345	510			
30	11.0	7.9	17.0	8.5	M10	9.0	M3-5 deep	1.50	40 000	57 800	690	1 000	495	715			
35	12.0	10.2	20.5	8.5	M10	9.0	M3-5 deep	2.25	55 600	81 000	1 200	1 740	830	1 215			
45	15.0	12.4	23.5	10.4	M12	14.0	M4-7 deep	4.30	90 400	128 500	2 440	3 470	1 700	2 425			

³⁾ Load capacities for version without ball chain. Load capacities for version without ball chain, see Product Overview with Load Capacities. Determination of the dynamic of the load capacities and moments is based on 100,000 m of stroke travel. Often only 50,000 m are actually stipulated. Comparison: Value C, M_t and M_L per table multiplied by 1.26.

Standard Runner Blocks, Steel Version

Runner Block FKS R1665

Flange Short

Versions:

- Runner block without ball chain:
See table for part numbers
- Runner block with low friction seal without ball chain:
Part numbers R1665 xxx 21
- Runner block with ball chain:
Part numbers R1665 xxx 22
- Runner block with low friction seal and ball chain:
Part numbers R1665 xxx 23

Dynamic Characteristics

Speed $v_{max} = 5 \text{ m/s}$

Acceleration $a_{max} = 500 \text{ m/s}^2$

Precision Runner Block

- Pre-lubricated

Corrosion resistant

Version Resist NR*

R2000

- Pre-lubricated

Resist NR Corrosion-resistant steel runner block

Resist NR without ball chain, see Table

Resist NR with low friction seal, without ball chain R2000 xxx 31

Resist NR with ball chain 2000 xxx 32

Resist NR with low friction seal and ball chain R2000 xxx 33

* In Preparation

Corrosion resistant

Custom version Resist CR

- Pre-lubricated

Resist CR – Chromium-plated matt silver runner block housing instead of corrosion-resistant steel runner block housing

Resist CR without ball chain R1665 xxx 70

Resist CR with low friction seal, without ball chain R1665 xxx 71

Resist CR with ball chain R1665 xxx 72

Resist CR with low friction seal and ball chain R1665 xxx 73

Preload Class

C0 = without Preload

C1 = Preload 2% C

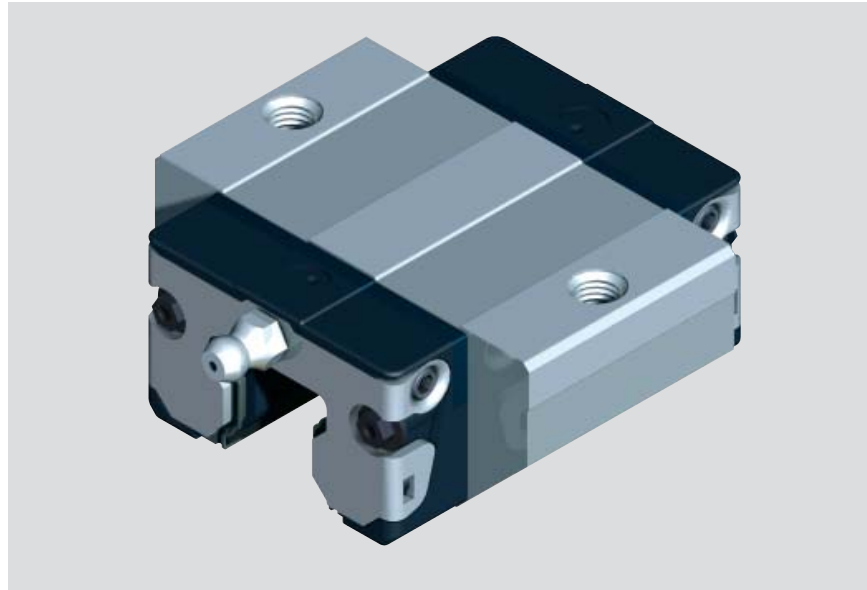

Size	Accuracy Class	Part numbers for runner blocks for preload class	
		C0	C1
15	N	R1665 194 20	R1665 114 20
	H	R1665 193 20	R1665 113 20
20	N	R1665 894 20	R1665 814 20
	H	R1665 893 20	R1665 813 20
25	N	R1665 294 20	R1665 214 20
	H	R1665 293 20	R1665 213 20
30	N	R1665 794 20	R1665 714 20
	H	R1665 793 20	R1665 713 20
35	N	R1665 394 20	R1665 314 20
	H	R1665 393 20	R1665 313 20

Size	Accuracy Class	Part numbers for runner blocks for preload class	
		C0	C1
15	H	R2000 193 30	
20	H	R2000 893 30	
25	H	R2000 293 30	
30	H	R2000 793 30	R2000 713 30
35	H	R2000 393 30	R2000 313 30

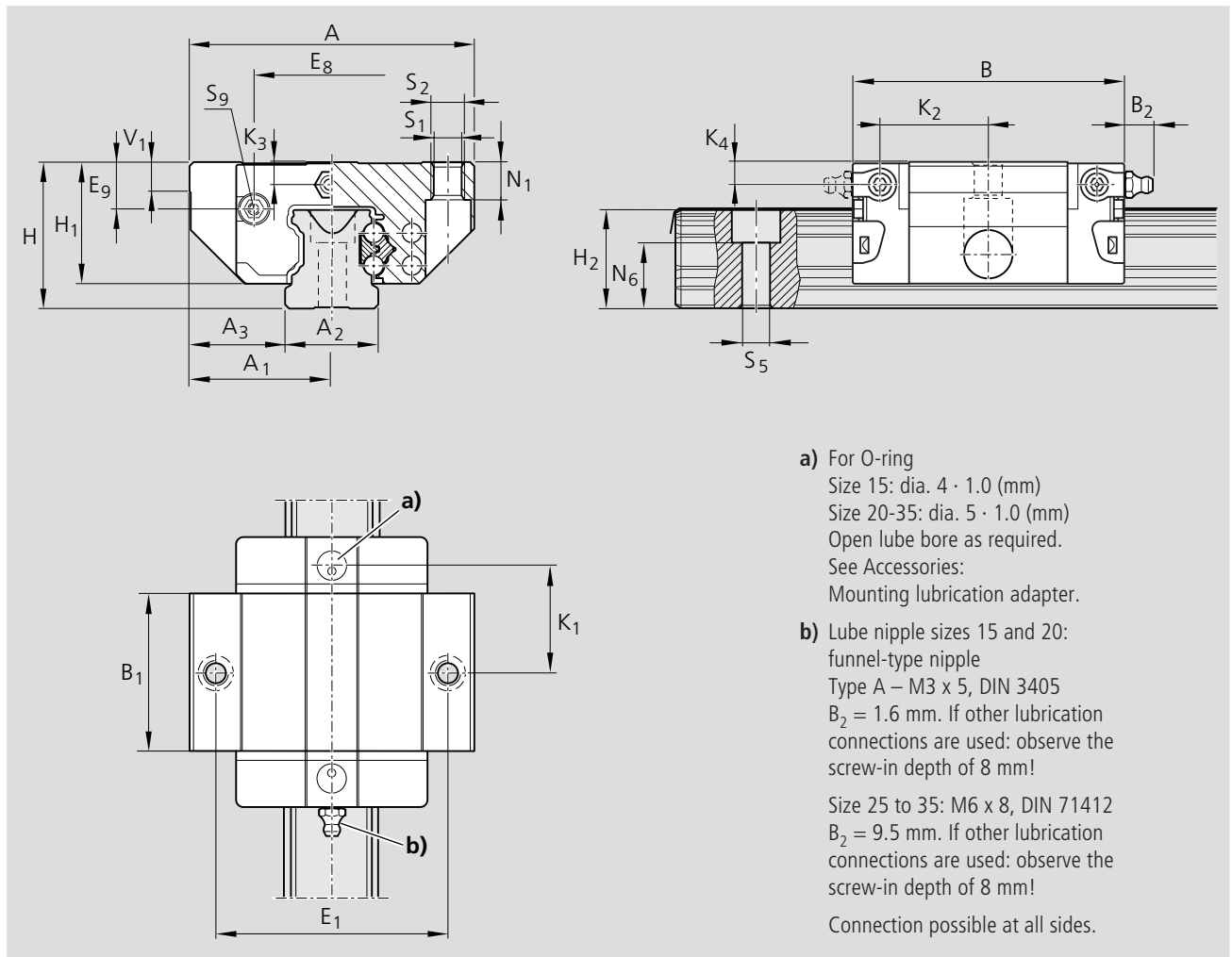

Size	Dimensions (mm)																	
	A	A ₁	A ₂	A ₃	B	B ₁	H	H ₁	H ₂ ¹⁾	H ₂ ²⁾	V ₁	E ₁	E ₈	E ₉	K ₁	K ₂	K ₃	K ₄
15	47	23.5	15	16.0	44.7	25.7	24	19.90	16.30	16.20	5.0	38	24.55	6.70	16.25	17.85	3.20	3.20
20	63	31.5	20	21.5	57.3	31.9	30	25.35	20.75	20.55	6.0	53	32.50	7.30	22.95	22.95	3.35	3.35
25	70	35.0	23	23.5	67.0	38.6	36	29.90	24.45	24.25	7.5	57	38.30	11.50	25.35	26.50	5.50	5.50
30	90	45.0	28	31.0	75.3	45.0	42	35.35	28.55	28.35	7.0	72	48.40	14.60	28.80	30.50	6.05	6.05
35	100	50.0	34	33.0	84.9	51.4	48	40.40	32.15	31.85	8.0	82	58.00	17.35	32.70	34.20	6.90	6.90

¹⁾ Dimension H₂ with rail seal cover strip

²⁾ Dimension H₂ without rail seal cover strip

Size	N ₁	Dimensions (mm)						Mass (kg)	Load capacities (N) ³⁾		Moments (Nm)			
		N ₆ ^{±0.5}	S ₁	S ₂	S ₅	S ₉	C dyn.		C ₀ stat.	M _t dyn.	M _{t0} stat.	M _L dyn.	M _{L0} stat.	
15	5.2	10.3	4.3	M5	4.4	M2.5-3.5deep	0.15	5 400	8 100	52	80	19	28	
20	7.7	13.2	5.3	M6	6.0	M3-5deep	0.30	12 400	13 600	150	170	52	58	
25	9.3	15.2	6.7	M8	7.0	M3-5deep	0.50	15 900	18 200	230	260	82	94	
30	11.0	17.0	8.5	M10	9.0	M3-5deep	0.80	22 100	24 800	380	430	133	150	
35	12.0	20.5	8.5	M10	9.0	M3-5deep	1.20	29 300	32 400	640	700	200	220	

³⁾ Load capacities for version without ball chain. Load capacities for version without ball chain, see Product Overview with Load Capacities. Determination of the dynamic of the load capacities and moments is based on 100,000 m of stroke travel. Often only 50,000 m are actually stipulated. Comparison: Value C, M_t and M_L per table multiplied by 1.26.

Runner Blocks Slimline, Steel Version

Runner Block SNS R1622

Slimline Standard

Versions:

- Runner block without ball chain:
for part numbers, see table
- Runner block with low friction seal
without ball chain**:
Part numbers R1622 xxx 21
- Runner block with ball chain:
part numbers R1622 xxx 21
- Runner block with low friction seal
with ball chain**:
Part numbers R1622 xxx 22

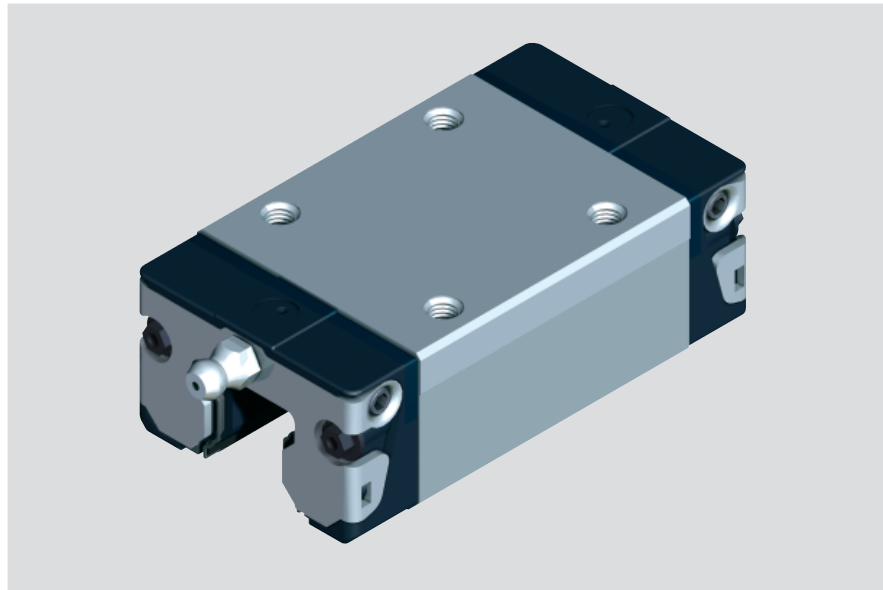

Dynamic Characteristics

Speed $v_{max} = 5 \text{ m/s}$

Acceleration $a_{max} = 500 \text{ m/s}^2$

Precision Runner Block

- Pre-lubricated

Corrosion resistant version

- Pre-lubricated

For Resist NR corrosion-resistant Steel runner block, see appropriate section.

For Resist NR II - All corrosion-resistant steel parts, see appropriate section.

High Precision Runner Blocks

- Further improved movement accuracy
- Superior quality
- Highest precision
- Pre-lubricated
- Minimal oil preservation

Preload Class

C0 = without Preload

C1 = Preload 2% C

C2 = Preload 8% C

C3 = Preload 13% C

For further technical information, please see chapter on "General Technical Data and Calculations".

Size	Accuracy Class	Part numbers for runner blocks for preload class		
		C0	C1	C2
15	N	R1622 194 20	R1622 114 20	R1622 124 20
	H	R1622 193 20	R1622 113 20	R1622 123 20
	P		R1622 112 20	R1622 122 20
20	N	R1622 894 20	R1622 814 20	R1622 824 20
	H	R1622 893 20	R1622 813 20	R1622 823 20
	P		R1622 812 20	R1622 822 20
25	N	R1622 294 20	R1622 214 20	R1622 224 20
	H	R1622 293 20	R1622 213 20	R1622 223 20
	P		R1622 212 20	R1622 222 20
30	N	R1622 794 20	R1622 714 20	R1622 724 20
	H	R1622 793 20	R1622 713 20	R1622 723 20
	P		R1622 712 20	R1622 722 20
35	N	R1622 394 20	R1622 314 20	R1622 324 20
	H	R1622 393 20	R1622 313 20	R1622 323 20
	P		R1622 312 20	R1622 322 20
45*	N	R1622 494 20	R1622 414 20	R1622 424 20
	H	R1622 493 20	R1622 413 20	R1622 423 20
	P		R1622 412 20	R1622 422 20

Size	Accuracy Class	Part numbers for runner blocks for preload class		
		C1	C2	C3
15	XP	R1622 118 20	R1622 128 20	R1622 138 20
20	XP	R1622 818 20	R1622 828 20	R1622 838 20
25	XP	R1622 218 20	R1622 228 20	R1622 238 20
30	XP	R1622 718 20	R1622 728 20	R1622 738 20
35	XP	R1622 318 20	R1622 328 20	R1622 338 20
45*	XP	R1622 418 20	R1622 428 20	R1622 438 20

* No delivery with low friction seal

** Low friction seal available for preload C0 and C1 (only for precision classes N, H, XP)

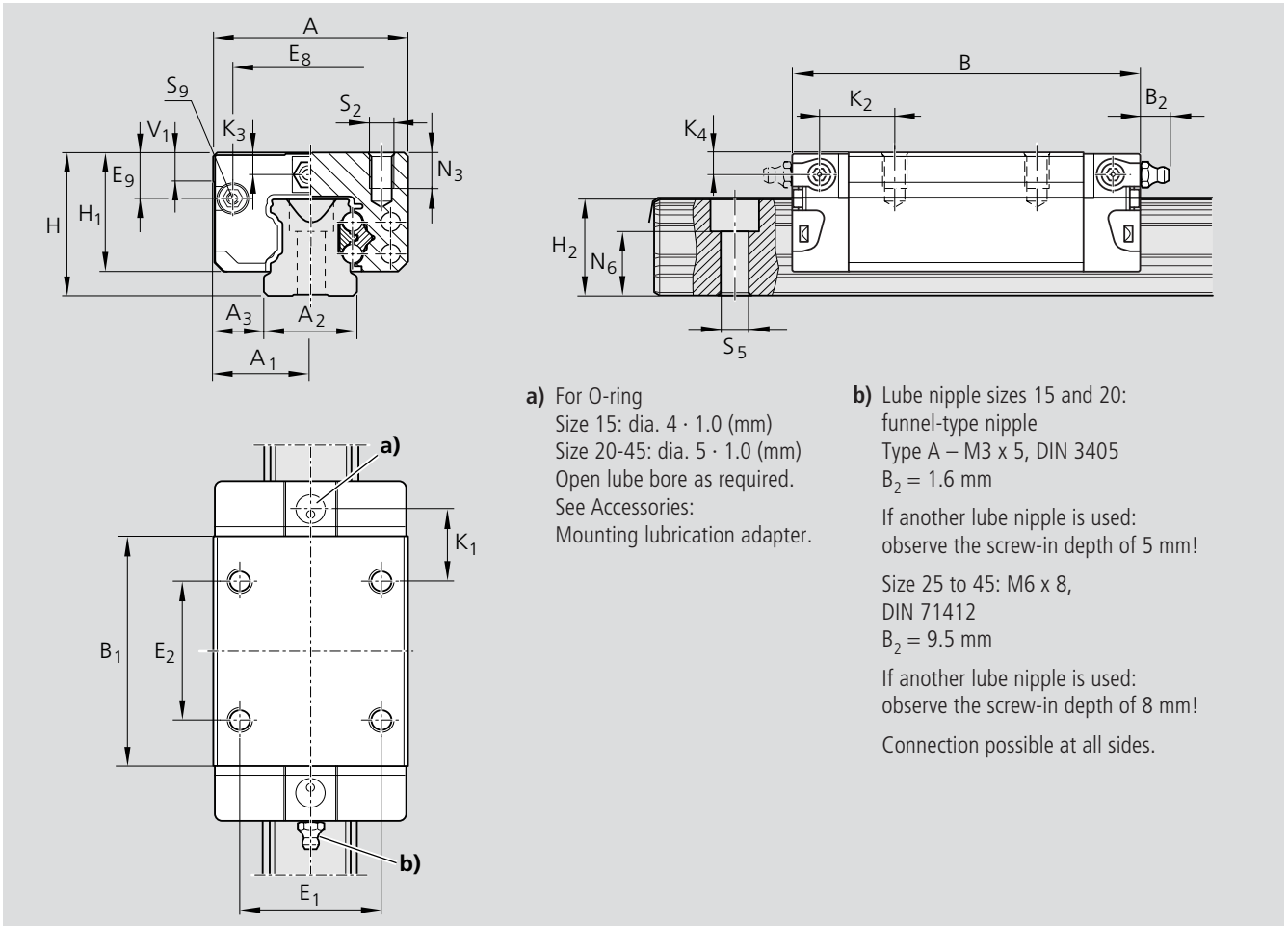

a) For O-ring
 Size 15: dia. 4 · 1.0 (mm)
 Size 20-45: dia. 5 · 1.0 (mm)
 Open lube bore as required.
 See Accessories:
 Mounting lubrication adapter.

b) Lube nipple sizes 15 and 20:
 funnel-type nipple
 Type A – M3 x 5, DIN 3405
 B₂ = 1.6 mm
 If another lube nipple is used:
 observe the screw-in depth of 5 mm!
 Size 25 to 45: M6 x 8,
 DIN 71412
 B₂ = 9.5 mm
 If another lube nipple is used:
 observe the screw-in depth of 8 mm!
 Connection possible at all sides.

Size	Dimensions (mm)																			
	A	A ₁	A ₂	A ₃	B	B ₁	H	H ₁	H ₂ ¹⁾	H ₂ ²⁾	V ₁	E ₁	E ₂	E ₃	E ₈	E ₉	K ₁	K ₂	K ₃	K ₄
15	34	23.5	15	16.0	72.6	53.6	24	19.90	16.30	16.20	5.0	38	30	26	24.55	6.70	15.20	16.80	3.20	3.20
20	44	31.5	20	21.5	91.0	65.6	30	25.35	20.75	20.55	6.0	53	40	35	32.50	7.30	19.80	19.80	3.35	3.35
25	48	35.0	23	23.5	107.9	79.5	36	29.90	24.45	24.25	7.5	57	45	40	38.30	11.50	23.30	24.45	5.50	5.50
30	60	45.0	28	31.0	119.7	89.4	42	35.35	28.55	28.35	7.0	72	52	44	48.40	14.60	25.00	26.70	6.05	6.05
35	70	50.0	34	33.0	139.0	105.5	48	40.40	32.15	31.85	8.0	82	62	52	58.00	17.35	28.75	30.25	6.90	6.90
45	86	60.0	45	37.5	174.1	133.5	60	50.30	40.15	39.85	10.0	100	80	60	69.80	20.90	35.50	37.50	8.20	8.20

¹⁾ Dimension H₂ with rail seal cover strip

²⁾ Dimension H₂ without rail seal cover strip

Size	Dimensions (mm)								Mass (kg)	Load Capacities (N) ³⁾		Moments (Nm)			
	N ₁	N ₂	N ₆ ^{±0.5}	S ₁	S ₂	S ₅	S ₉	C dyn.		C ₀ stat.	M _t		M _L		
											dyn.	stat.	dyn.	stat.	
15	5.2	4.4	10.3	4.3	M5	4.4	M2.5-3.5 deep	0.30	10 000	20 200	130	190	98	150	
20	7.7	5.2	13.2	5.3	M6	6.0	M3-5 deep	0.55	24 400	35 200	310	450	225	330	
25	9.3	7.0	15.2	6.7	M8	7.0	M3-5 deep	0.90	30 400	45 500	430	650	345	510	
30	11.0	7.9	17.0	8.5	M10	9.0	M3-5 deep	1.50	40 000	57 800	690	1 000	495	715	
35	12.0	10.2	20.5	8.5	M10	9.0	M3-5 deep	2.25	55 600	81 000	1 200	1 740	830	1 215	
45	15.0	12.4	23.5	10.4	M12	14.0	M4-7 deep	4.30	90 400	128 500	2 440	3 470	1 700	2 425	

³⁾ Load capacities for version without ball chain. Load capacities for version without ball chain, see Product Overview with Load Capacities. Determination of the dynamic of the load capacities and moments is based on 100,000 m of stroke travel. Often only 50,000 m are actually stipulated. Comparison: Value C, M_t and M_L per table multiplied by 1.26.

Standard Runner Blocks, Steel Version

Runner Block SNS R1622

Slimline Standard

– Runner block without ball chain:
for part numbers, see table

Dynamic characteristics

Speed $v_{max} = 3 \text{ m/s}$
Acceleration $a_{max} = 250 \text{ m/s}^2$

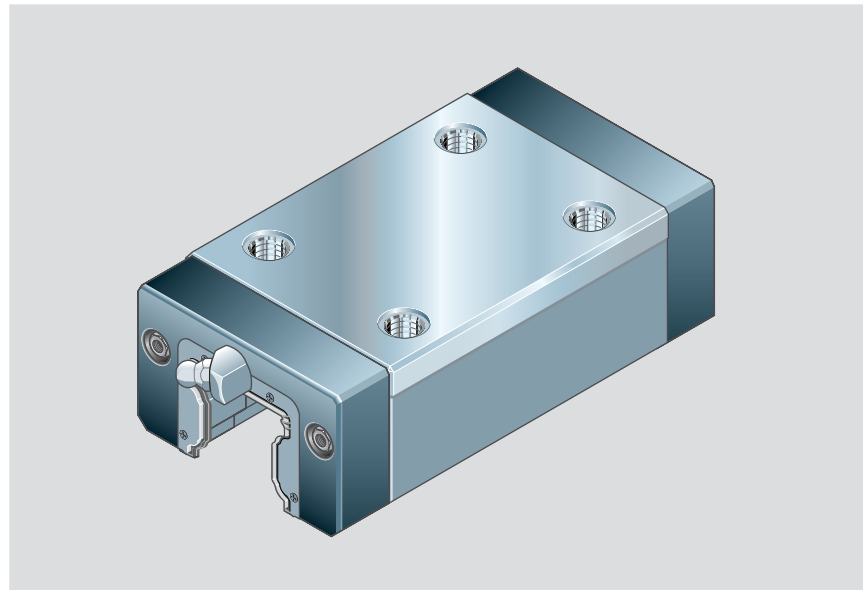

Precision Runner Blocks

– Not Pre-lubricated

Size	Accuracy Class	Part numbers for runner blocks for preload class			
		C0	C1	C2	C3
55	N	R1622 594 10	R1622 514 10	R1622 524 10	
	H	R1622 593 10	R1622 513 10	R1622 523 10	
	P		R1622 512 10	R1622 522 10	R1622 532 10
65	N	R1622 694 10	R1622 614 10	R1622 624 10	
	H	R1622 693 10	R1622 613 10	R1622 623 10	
	P		R1622 612 10	R1622 622 10	R1622 632 10

Corrosion resistant versions

Resist CR – Runner Block housing hard
Chromium-plated matt silver

– Not Pre-lubricated

Size	Accuracy Class	Part numbers for runner blocks for preload class	
		C0	C1
55	H	R1622 593 60	R1622 513 60
65	H	R1622 693 60	R1622 613 60

Preload Class

C0 = without Preload

C1 = Preload 2% C

C2 = Preload 8% C

C3 = Preload 13% C

For further technical information, please see chapter on "General Technical Data and Calculations".

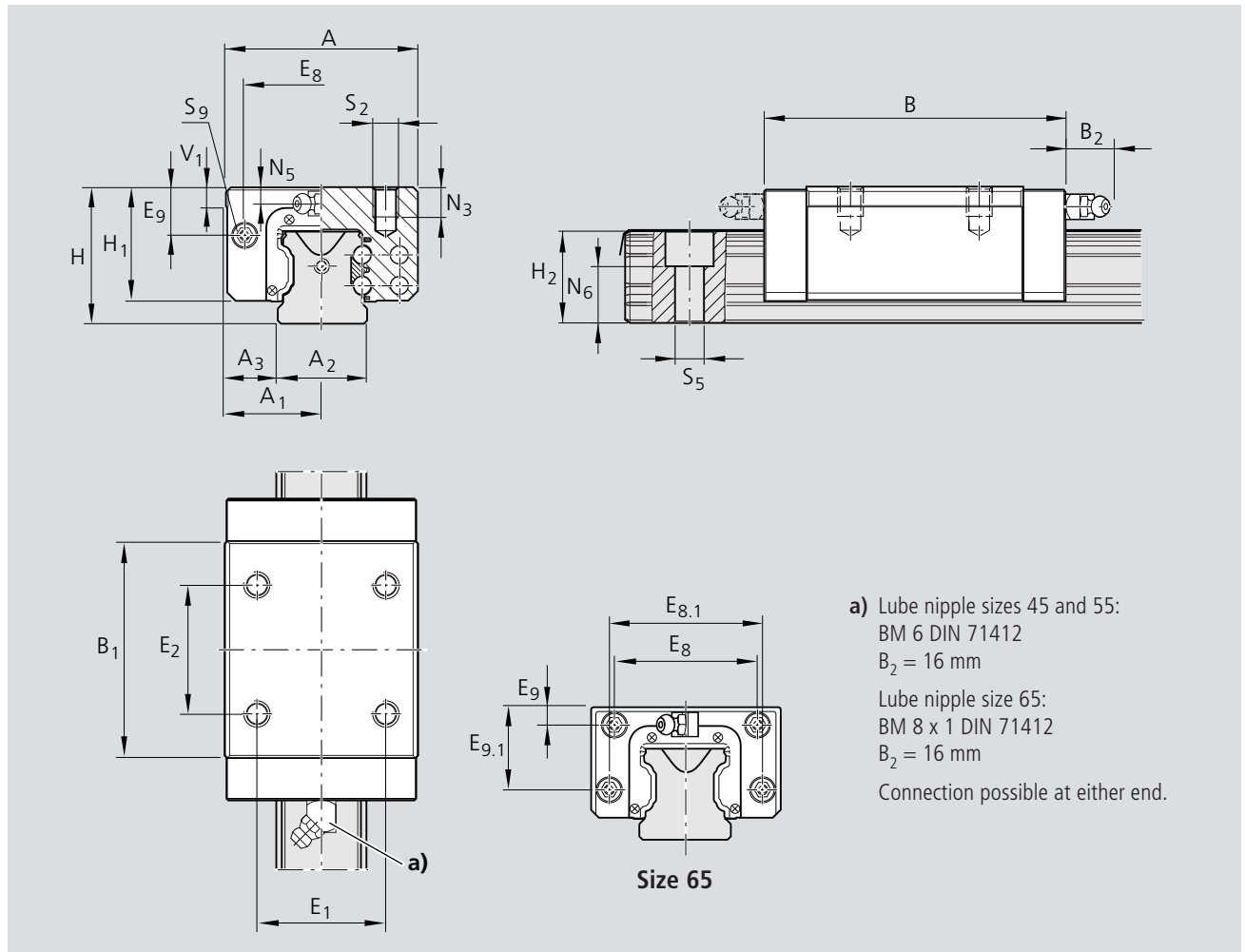

a) Lube nipple sizes 45 and 55:
 BM 6 DIN 71412
 $B_2 = 16 \text{ mm}$
 Lube nipple size 65:
 BM 8 x 1 DIN 71412
 $B_2 = 16 \text{ mm}$
 Connection possible at either end.

Dimensions (mm)																		
Size	A	A ₁	A ₂	A ₃	B	B ₁	H	H ₁	H ₂ ¹⁾	H ₂ ²⁾	V ₁	E ₁	E ₂	E ₈	E _{8.1}	E ₉	E _{9.1}	N ₃
55	100	50	53	23.5	159	115.5	70	57.0	48.15	47.85	12.0	75	75	80.0	100	22.3	11.0	19.0
65	126	63	63	31.5	188	139.6	90	76.0	60.15	59.85	15.0	76	70	76.0	100	11.0	53.5	21.0

¹⁾ Dimension H₂ with rail seal cover strip

²⁾ Dimension H₂ without rail seal cover strip

Size	Dimensions (mm)					Mass (kg)	Load capacities (N)				Moments (Nm)	
	N ₅	N ₆ ^{±0.5}	S ₂	S ₅	S ₉		C dyn.	C ₀ stat.	M _t dyn.	M _{t0} stat.	M _L dyn.	M _{L0} stat.
55	9.0	29.0	M12	16.0	M5-8 deep	3.80	98 200	121 400	3 100	3 860	1 540	1 905
65	16.0	38.5	M16	18.0	M4-7 deep	6.90	123 000	192 700	6 300	7 610	3 160	3 815

¹³⁾ Load capacities for version without ball chain. Load capacities for version without ball chain, see Product Overview with Load Capacities. Determination of the dynamic of the load capacities and moments is based on 100,000 m of stroke travel. Often only 50,000 m are actually stipulated. Comparison: Value C, M_t and M_L per table multiplied by 1.26.

Runner Blocks, Corrosion-resistant Steel - Resist NR¹⁾

Runner Block SNS R2011

Slimline Long

- Runner block without ball chain:
for part numbers, see table
- Runner block with low friction seal
without ball chain:
Part numbers R2011 xxx 31
- Runner block with ball chain:
Part numbers R2011 xxx 32
- Runner block with low friction seal
and ball chain:
Part numbers R2011 xxx 33

Dynamic Characteristics

Speed $v_{max} = 5 \text{ m/s}$
 Acceleration $a_{max} = 500 \text{ m/s}^2$

Precision Runner Block

- Pre-lubricated

Corrosion resistant Custom version

- Pre-lubricated

Resist CR – Chromium-plated matt silver runner block housing instead of corrosion-resistant steel runner block

Resist CR without ball chain R1622 xxx 70

Resist CR with low friction seal, without ball chain R1622 xxx 71

Resist CR without ball chain R1622 xxx 72

Resist CR with low friction seal and ball chain R1622 xxx 73

Preload Class

C0 = without Preload
 C1 = Preload 2% C

For further technical information, please see chapter on "General Technical Data and Calculations".

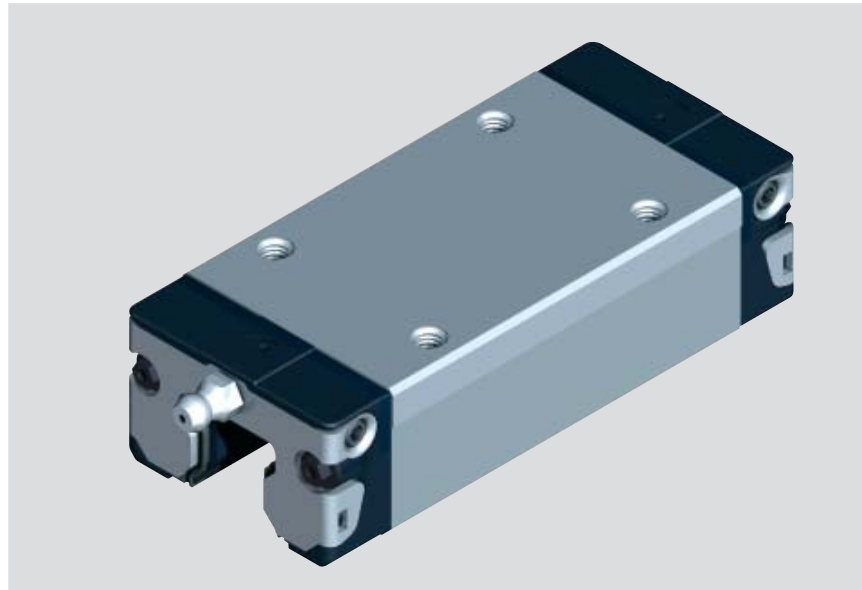

Size	Accuracy Class	Part numbers for runner blocks for preload class	
		C0	C1
15	H	R2011 193 30	R2011 128 30
20	H	R2011 893 30	R2011 828 30
25	H	R2011 293 30	R2011 228 30
30	H	R2011 793 30	R2011 728 30
35	H	R2011 393 30	R2011 328 30
45 ²⁾	H	(R2011 493 70)	(R2011 428 70)

1) In Preparation

2) Only available in chromium plated matt silver Resist CR at this time, no delivery on the low friction seal option

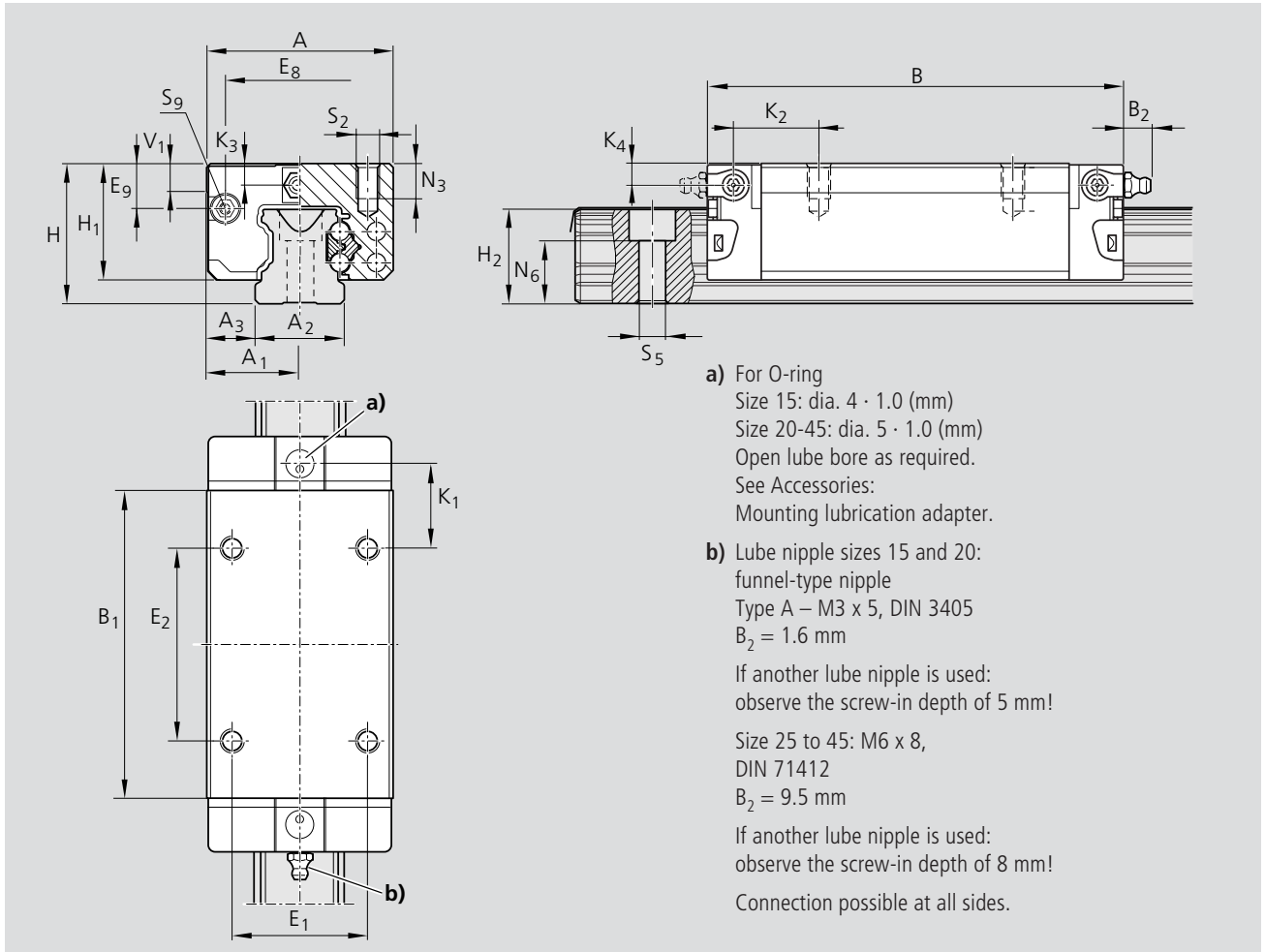

Dimensions (mm)																			
Size	A	A ₁	A ₂	A ₃	B	B ₁	H	H ₁	H ₂ ¹⁾	H ₂ ²⁾	V ₁	E ₁	E ₂	E ₈	E ₉	K ₁	K ₂	K ₃	K ₄
15	34	17	15	9.5	72.6	53.6	24	19.90	16.30	16.20	5.0	26	26	24.55	6.70	17.20	18.80	3.20	3.20
20	44	22	20	12.0	91.0	65.6	30	25.35	20.75	20.55	6.0	32	50	32.50	7.30	14.80	14.80	3.35	3.35
25	48	24	23	12.5	107.9	79.5	36	29.90	24.45	24.25	7.5	35	50	38.30	11.50	20.80	21.95	5.50	5.50
30	60	30	28	16.0	119.7	89.4	42	35.35	28.55	28.35	7.0	40	60	48.40	14.60	21.00	22.70	6.05	6.05
35	70	35	34	18.0	139.0	105.5	48	40.40	32.15	31.85	8.0	50	72	58.00	17.35	23.75	25.25	6.90	6.90
45	86	43	45	20.5	174.1	133.5	60	50.3	40.15	39.85	10.0	60	80	69.8	20.90	35.50	37.50	8.20	8.20

¹⁾ Dimension H₂ with rail seal cover strip

²⁾ Dimension H₂ without rail seal cover strip

Size	Dimensions (mm)					Mass (kg)	Load capacities (N) ³⁾		Moments (Nm)			
	N ₃	N ₆ ^{±0.5}	S ₂	S ₅	S ₉		C dyn.	C ₀ stat.	M _t dyn.	M _{t0} stat.	M _L dyn.	M _{L0} stat.
15	6.0	10.3	M4	4.4	M2.5-3.5 deep	0.20	10 000	20 200	130	190	98	150
20	7.5	13.2	M5	6.0	M3-5 deep	0.45	24 400	35 200	310	450	225	330
25	9.0	15.2	M6	7.0	M3-5 deep	0.65	30 400	45 500	430	650	345	510
30	12.0	17.0	M8	9.0	M3-5 deep	1.10	40 000	57 800	690	1 000	495	715
35	13.0	20.5	M8	9.0	M3-5 deep	1.70	55 600	81 000	1 200	1 740	830	1 215
45	18.0	23.5	M10	14.0	M4-7 deep	3.20	90 400	128 500	2 440	3 470	1 700	2 425

³⁾ Load capacities for version without ball chain. Load capacities for version without ball chain, see Product Overview with Load Capacities. Determination of the dynamic of the load capacities and moments is based on 100,000 m of stroke travel. Often only 50,000 m are actually stipulated. Comparison: Value C, M_t and M_L per table multiplied by 1.26.

Runner Blocks, Steel Version

Runner Block SNS R1623

Slimline Long

- Runner block without ball chain:
for part numbers, see table
- Runner block with low friction seal without ball chain**:
Part numbers R1623 xxx 21
- Runner block with ball chain:
Part numbers R1623 xxx 22
- Runner block with Low friction seal und ball chain**:
Part numbers R1623 xxx 23

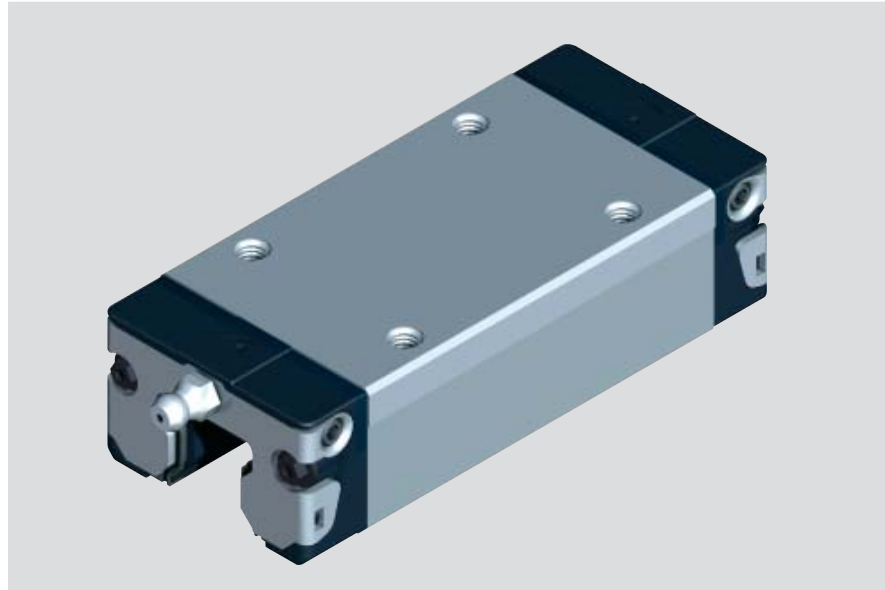

Dynamic Characteristics

Speed $v_{max} = 5 \text{ m/s}$
 Acceleration $a_{max} = 500 \text{ m/s}^2$

Precision Runner Block

- Pre-lubricated

Corrosion resistant version

- Pre-lubricated

For Resist NR corrosion-resistant steel runner block, see appropriate section.

For Resist NR II - All corrosion-resistant steel parts, see appropriate section.

High Precision Runner Blocks

- Improved travel accuracy
- Superior quality
- Highest precision
- Pre-lubricated
- Minimal preservation

Preload Class

C0 = without Preload
 C1 = Preload 2% C
 C2 = Preload 8% C
 C3 = Preload 13% C

For further technical information, please see chapter on "General Technical Data and Calculations".

Size	Accuracy Class	Part numbers for runner blocks for preload class		
		C0	C1	C2
15	N	R1623 194 20	R1623 114 20	R1623 124 20
	H	R1623 193 20	R1623 114 20	R1623 123 20
	P		R1623 112 20	R1623 122 20
20	N	R1623 894 20	R1623 814 20	R1623 824 20
	H	R1623 893 20	R1623 813 20	R1623 823 20
	P		R1623 812 20	R1623 822 20
25	N	R1623 294 20	R1623 214 20	R1623 224 20
	H	R1623 293 20	R1623 213 20	R1623 223 20
	P		R1623 212 20	R1623 222 20
30	N	R1623 794 20	R1623 714 20	R1623 724 20
	H	R1623 793 20	R1623 713 20	R1623 723 20
	P		R1623 712 20	R1623 722 20
35	N	R1623 394 20	R1623 314 20	R1623 324 20
	H	R1623 393 20	R1623 313 20	R1623 323 20
	P		R1623 312 20	R1623 322 20
45*	N	R1623 494 20	R1623 414 20	R1623 424 20
	H	R1623 493 20	R1623 413 20	R1623 423 20
	P		R1623 412 20	R1623 422 20

Size	Accuracy Class	Part numbers for runner blocks for preload class		
		C1	C2	C3
15	XP	R1623 118 20	R1623 128 20	R1623 138 20
20	XP	R1623 818 20	R1623 828 20	R1623 838 20
25	XP	R1623 218 20	R1623 228 20	R1623 238 20
30	XP	R1623 718 20	R1623 728 20	R1623 738 20
35	XP	R1623 318 20	R1623 328 20	R1623 338 20
45*	XP	R1623 418 20	R1623 428 20	R1623 438 20

* No delivery with low friction seal

** Low friction seal available for preload C0 and C1 (only for precision classes N, H, XP)

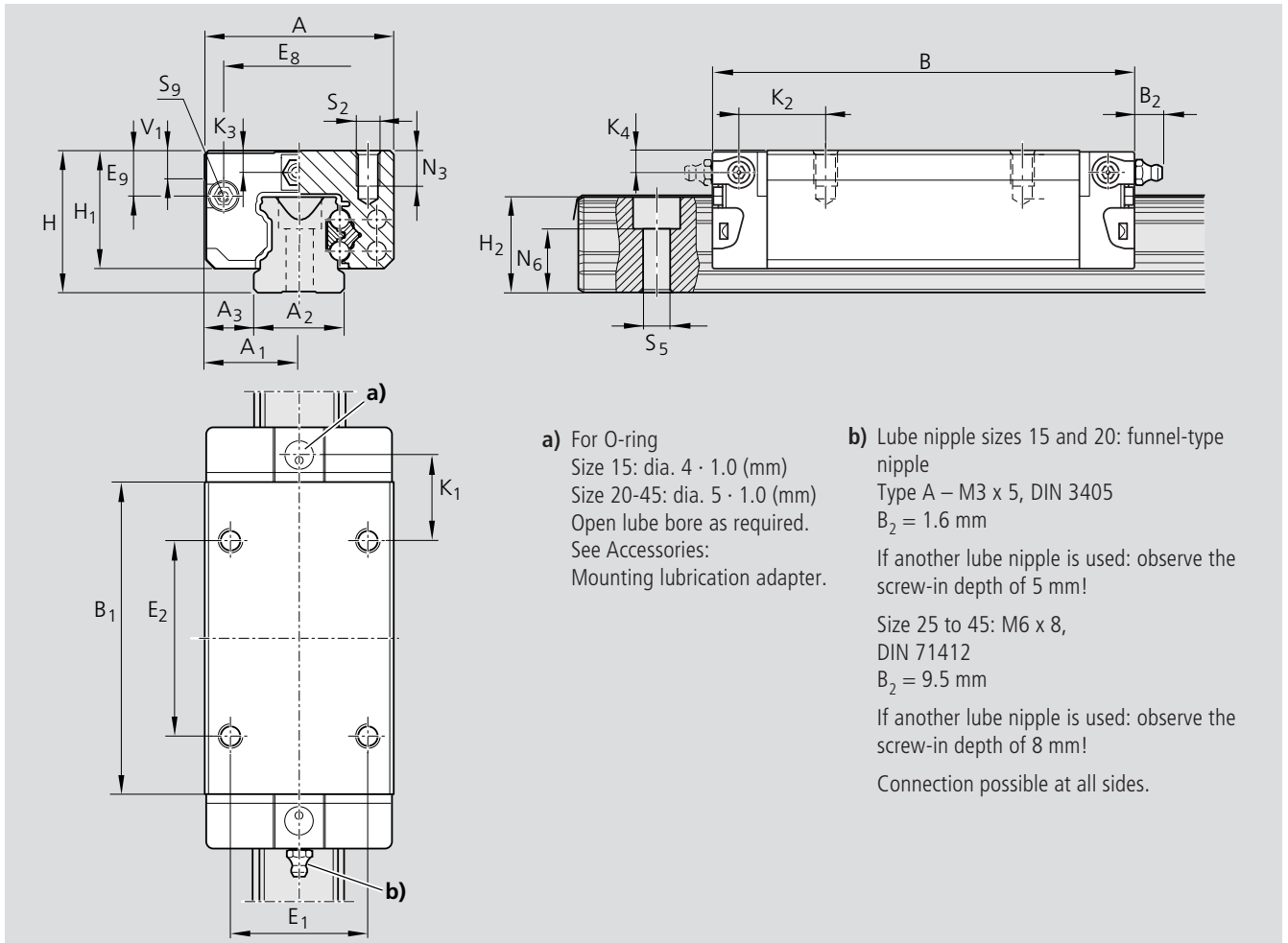

Dimensions (mm)																			
Size	A	A ₁	A ₂	A ₃	B	B ₁	H	H ₁	H ₂ ¹⁾	H ₂ ²⁾	V ₁	E ₁	E ₂	E ₈	E ₉	K ₁	K ₂	K ₃	K ₄
15	34	17	15	9.5	72.6	53.6	24	19.90	16.30	16.20	5.0	26	26	24.55	6.70	17.20	18.80	3.20	3.20
20	44	22	20	12.0	91.0	65.6	30	25.35	20.75	20.55	6.0	32	50	32.50	7.30	14.80	14.80	3.35	3.35
25	48	24	23	12.5	107.9	79.5	36	29.90	24.45	24.25	7.5	35	50	38.30	11.50	20.80	21.95	5.50	5.50
30	60	30	28	16.0	119.7	89.4	42	35.35	28.55	28.35	7.0	40	60	48.40	14.60	21.00	22.70	6.05	6.05
35	70	35	34	18.0	139.0	105.5	48	40.40	32.15	31.85	8.0	50	72	58.00	17.35	23.75	25.25	6.90	6.90
45	86	43	45	20.5	174.1	133.5	60	50.30	40.15	39.85	10.0	60	80	69.80	20.90	35.50	37.50	8.20	8.20

¹⁾ Dimension H₂ with rail seal cover strip

²⁾ Dimension H₂ without rail seal cover strip

Size	Dimensions (mm)					Mass (kg)	Load Capacities (N) ³⁾				Moments (Nm)			
	N ₃	N ₆ ^{±0,5}	S ₂	S ₅	S ₉		C dyn.	C ₀ stat.	M _t dyn.	M _{t0} stat.	M _L dyn.	M _{L0} stat.		
15	6.0	10.3	M4	4.4	M2.5-3.5deep	0.20	10 000	20 200	130	190	98	150		
20	7.5	13.2	M5	6.0	M3-5 deep	0.45	24 400	35 200	310	450	225	330		
25	9.0	15.2	M6	7.0	M3-5 deep	0.65	30 400	45 500	430	650	345	510		
30	12.0	17.0	M8	9.0	M3-5 deep	1.10	40 000	57 800	690	1 000	495	715		
35	13.0	20.5	M8	9.0	M3-5 deep	1.70	55 600	81 000	1 200	1 740	830	1 215		
45	18.0	23.5	M10	14.0	M4-7 deep	3.20	90 400	128 500	2 440	3 470	1 700	2 425		

³⁾ Load capacities for version without ball chain. Load capacities for version without ball chain, see Product Overview with Load Capacities. Determination of the dynamic of the load capacities and moments is based on 100,000 m of stroke travel. Often only 50,000 m are actually stipulated. Comparison: Value C, M_t and M_L per table multiplied by 1.26.

Standard Runner Blocks, Steel Version

Runner Block SLS R1623

Slimline Long

- Runner Block with ball chain:
See table for part numbers

Dynamic Characteristics

Speed $v_{max} = 3 \text{ m/s}$
 Acceleration $a_{max} = 250 \text{ m/s}^2$.

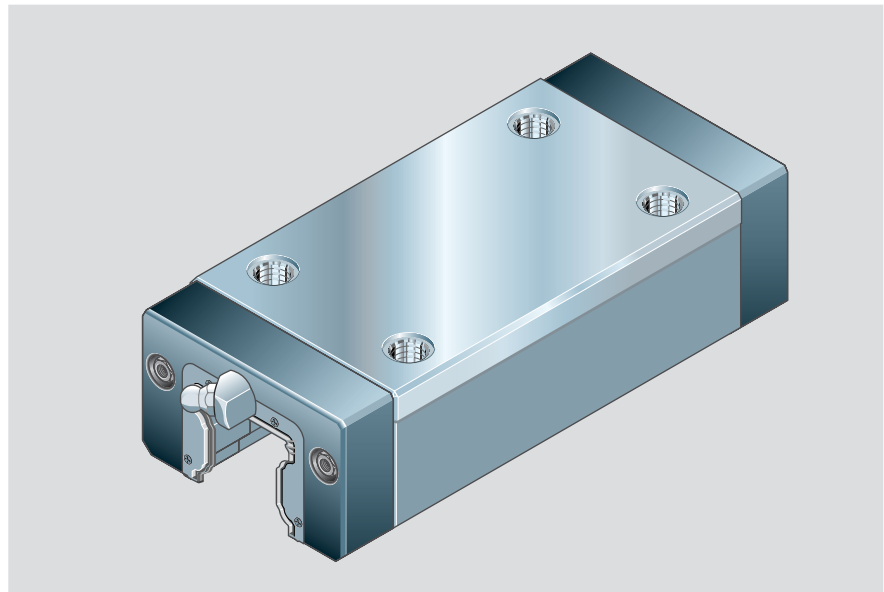

High Precision Runner Blocks

- Not Pre-lubricated

Size	Accuracy Class	Part numbers for runner blocks for preload class			
		C0	C1	C2	C3
55	N	R1623 594 10	R1623 514 10	R1623 524 10	
	H	R1623 593 10	R1623 513 10	R1623 523 10	
	P		R1623 512 10	R1623 522 10	R1623 532 10
65	N	R1623 694 10	R1623 614 10	R1623 624 10	
	H	R1623 693 10	R1623 613 10	R1623 623 10	
	P		R1623 612 10	R1623 622 10	R1623 632 10

Corrosion resistant Custom version

Resist CR – Chromium-plated matt silver runner block housing

- Not Pre-lubricated

Size	Accuracy Class	Part numbers for runner blocks for preload class	
		C0	C1
55	H	R1623 593 60	R1623 513 60
65	H	R1623 693 60	R1623 613 60

Preload Class

- C0 = without Preload
- C1 = Preload 2% C
- C2 = Preload 8% C
- C3 = Preload 13% C

For further technical information, please see chapter on "General Technical Data and Calculations".

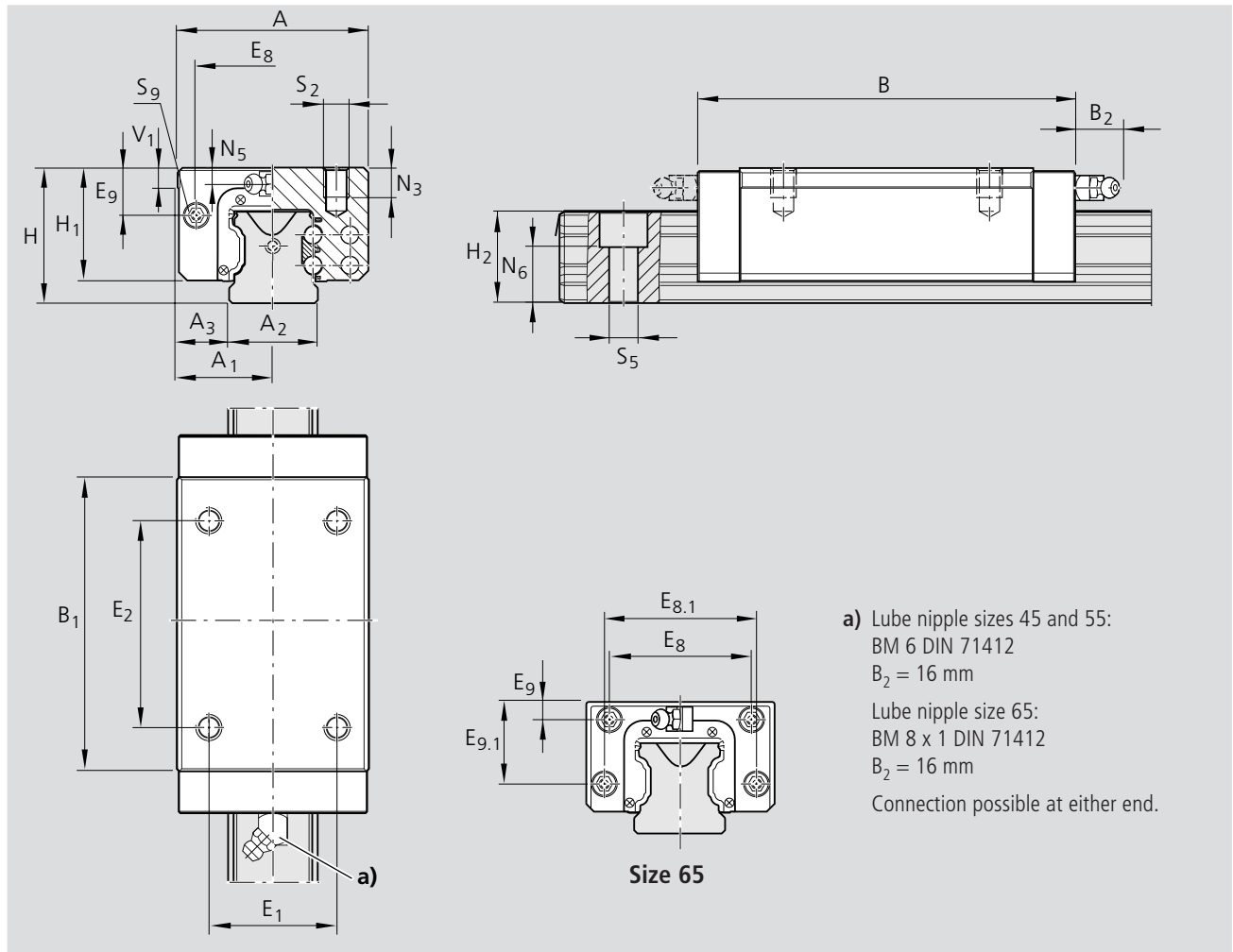

Size	Dimensions (mm)																	
	A	A ₁	A ₂	A ₃	B	B ₁	H	H ₁	H ₂ ¹⁾	H ₂ ²⁾	V ₁	E ₁	E ₂	E ₈	E _{8.1}	E ₉	E _{9.1}	N ₃
55	100	50	53	23.5	200.0	155.5	70	57.0	48.15	47.85	12.0	75	95	80.0		22.3		19.0
65	126	63	63	31.5	243.0	194.6	90	76.0	60.15	59.85	15.0	76	120	76.0	100	11.0	53.5	21.0

¹⁾ Dimension H₂ with rail seal cover strip

²⁾ Dimension H₂ without rail seal cover strip

Size	Dimensions (mm)						Mass (kg)	Load capacities (N) ³⁾				Moments (Nm)	
	N ₅	N ₆ ^{±0.5}	S ₂	S ₅	S ₉	C dyn.		C ₀ stat.	M _t dyn.	M _{t0} stat.	M _L dyn.	M _{L0} stat.	
55	9.0	29.2	M12	16.0	M5-8 deep	4.8	124 200	170 000	3 950	5 400	2 630	3 600	
65	16.0	38.5	M16	18.0	M4-7 deep	9.8	163 000	289 000	6 440	11 420	4 620	8 190	

³⁾ Load capacities for version without ball chain. Load capacities for version without ball chain, see Product Overview with Load Capacities. Determination of the dynamic of the load capacities and moments is based on 100,000 m of stroke travel. Often only 50,000 m are actually stipulated. Comparison: Value C, M_t and M_L per table multiplied by 1.26.

Runner Blocks, Corrosion-resistant Steel - Resist NR¹⁾

Runner Block SLS R2012

Slimline Long

Versions:

- Runner block without ball chain:
for part numbers, see table
- Runner block with low friction seal
without ball chain:
Part numbers R2012 xxx 31
- Runner block with ball chain:
Part numbers R2012 xxx 32
- Runner block with low friction seal with
ball chain:
Part numbers R2012 xxx 33

Dynamic characteristics

Speed $v_{\max} = 5 \text{ m/s}$
Acceleration $a_{\max} = 500 \text{ m/s}^2$

Precision Runner Block

- Pre-lubricated

Corrosion resistant Custom version

- Pre-lubricated

Resist CR – Chromium-plated matt silver
runner block housing instead of corrosion-
resistant steel runner block housing

Resist CR without ball chain R1623 xxx 70

Resist CR with low friction seal, without ball
chain R1623 xxx 71

Resist CR with ball chain R1623 xxx 72

Resist CR with low friction seal and ball
chain R1623 xxx 73

Preload Class

C0 = without Preload

C1 = Preload 2% C

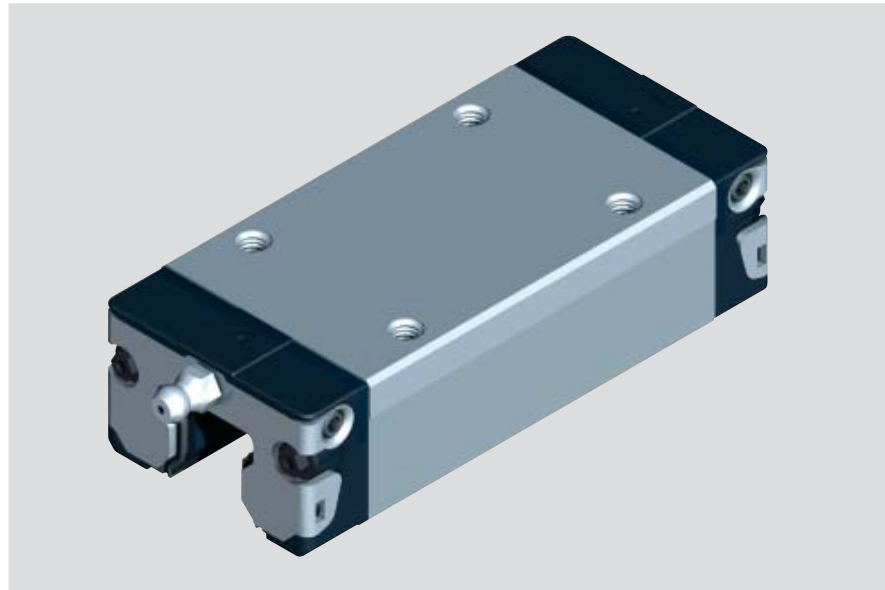

Size	Accuracy Class	Part numbers for runner blocks for preload class	
		C0	C1
15	H	R2012 193 30	
20	H	R2012 893 30	
25	H	R2012 293 30	
30	H	R2012 793 30	R2012 713 30
35	H	R2012 393 30	R2012 313 30
45 ²⁾	H	(R2012 493 70)	(R2012 413 70)

1) In Preparation

2) Only available in chromium plated matt silver Resist CR at this time, no delivery on the low friction seal option

For further technical information, please
see chapter on "General Technical Data
and Calculations".

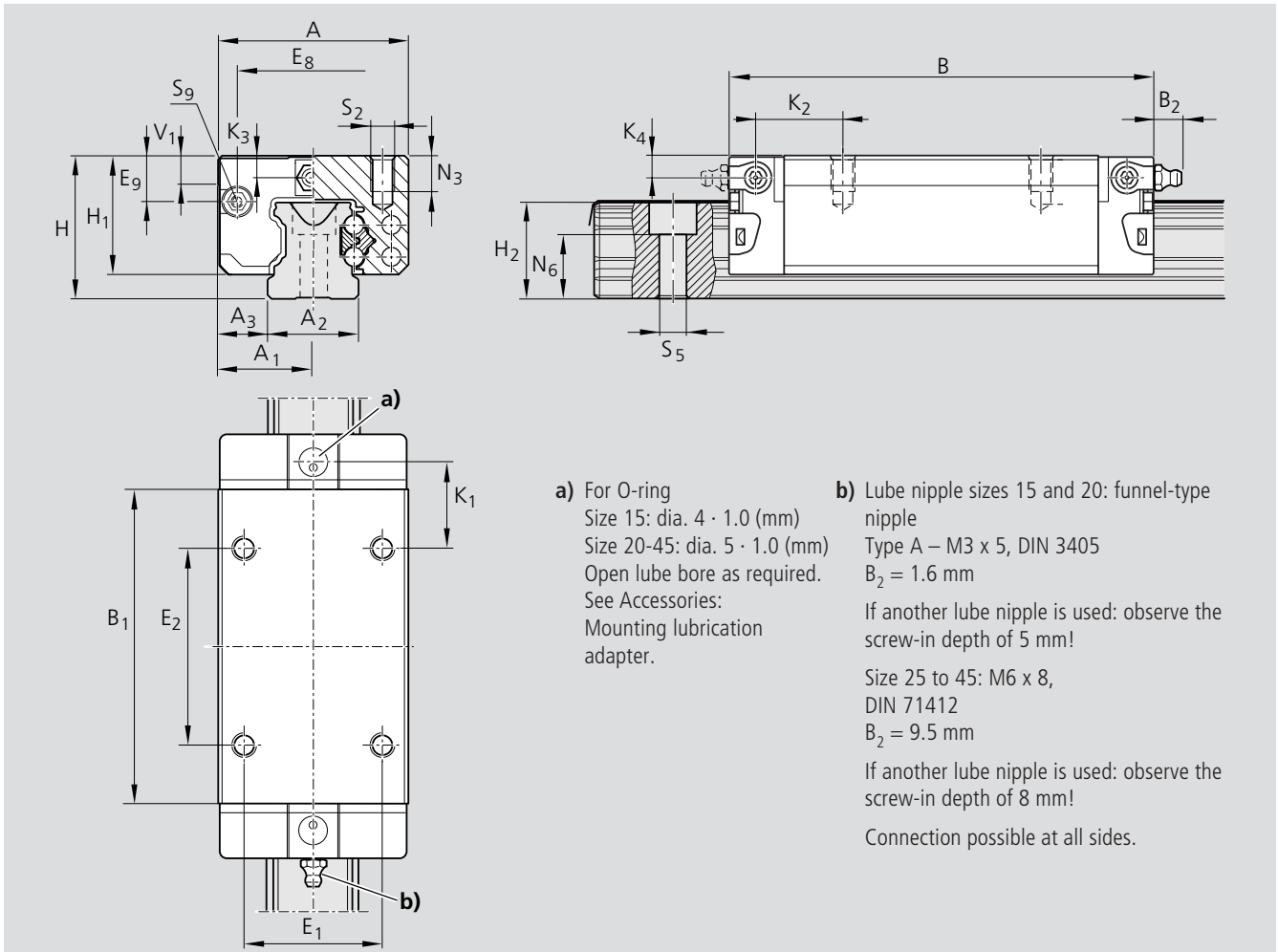

Dimensions (mm)																			
Size	A	A ₁	A ₂	A ₃	B	B ₁	H	H ₁	H ₂ ¹⁾	H ₂ ²⁾	V ₁	E ₁	E ₂	E ₈	E ₉	K ₁	K ₂	K ₃	K ₄
15	34	17	15	9.5	72.6	53.6	24	19.90	16.30	16.20	5.0	26	26	24.55	6.70	17.20	18.80	3.20	3.20
20	44	22	20	12.0	91.0	65.6	30	25.35	20.75	20.55	6.0	32	50	32.50	7.30	14.80	14.80	3.35	3.35
25	48	24	23	12.5	107.9	79.5	36	29.90	24.45	24.25	7.5	35	50	38.30	11.50	20.80	21.95	5.50	5.50
30	60	30	28	16.0	119.7	89.4	42	35.35	28.55	28.35	7.0	40	60	48.40	14.60	21.00	22.70	6.05	6.05
35	70	35	34	18.0	139.0	105.5	48	40.40	32.15	31.85	8.0	50	72	58.00	17.35	23.75	25.25	6.90	6.90
45	86	43	45	20.5	174.1	133.5	60	50.30	40.15	39.85	10.0	60	80	69.80	20.90	35.50	37.50	8.20	8.20

¹⁾ Dimension H₂ with rail seal cover strip

²⁾ Dimension H₂ without rail seal cover strip

Size	Dimensions (mm)					Weight dyn.	Load Capacities (N ³⁾		Moments (Nm)			
	N ₃	N ₆ ^{±0.5}	S ₂	S ₅	S ₉		C stat.	C ₀ dyn.	M _t stat.	M _{t0} dyn.	M _L stat.	M _{L0}
15	6.0	10.3	M4	4.4	M2.5-3.5deep	0.20	10 000	20 200	130	190	98	150
20	7.5	13.2	M5	6.0	M3-5 deep	0.45	24 400	35 200	310	450	225	330
25	9.0	15.2	M6	7.0	M3-5deep	0.65	30 400	45 500	430	650	345	510
30	12.0	17.0	M8	9.0	M3-5 deep	1.10	40 000	57 800	690	1 000	495	715
35	13.0	20.5	M8	9.0	M3-5 deep	1.70	55 600	81 000	1 200	1 740	830	1 215
45	18.0	23.5	M10	14.0	M4-7 deep	3.20	90 400	128 500	2 440	3 470	1 700	2 425

³⁾ Load capacities for version without ball chain. Load capacities for version without ball chain, see Product Overview with Load Capacities. Determination of the dynamic of the load capacities and moments is based on 100,000 m of stroke travel. Often only 50,000 m are actually stipulated. Comparison: Value C, M_t and M_L per table multiplied by 1.26.

Standard Runner Blocks, Steel Version

Runner Block SKS R1666

Slimline Short

- Runner block without ball chain:
for part numbers, see table
- Runner block with low friction seal
without ball chain:
Part numbers R1666 xxx 21
- Runner block with ball chain:
Part numbers R1666 xxx 22
- Runner block without low friction seal
and ball chain:
Part numbers R1666 xxx 23

Dynamic Characteristics

Speed $v_{max} = 5 \text{ m/s}$
 Acceleration $a_{max} = 500 \text{ m/s}^2$

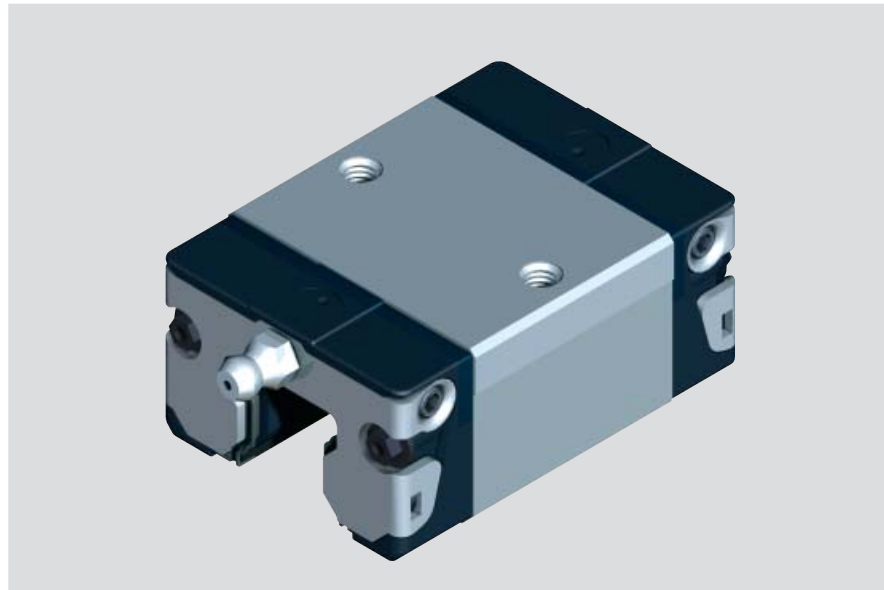

Precision Runner Block

– Pre-lubricated

Corrosion resistant version Res-ist NR* R2010

– Pre-lubricated

Resist NR without ball chain, see table

Resist NR with low friction seal, without ball chain R2010 xxx 31

Resist NR with ball chain 2010 xxx 32

Resist NR with low friction seal and ball chain R2010 xxx 33

– Pre-lubricated

* In Preparation

Corrosion resistant Custom version Resist CR

– Pre-lubricated

Chromium-plated matt silver runner block housing instead of corrosion-resistant steel runner block housing

Resist CR without ball chain R1665 xxx 70

Resist CR with low friction seal, without ball chain R1665 xxx 71

Resist CR with ball chain R1665 xxx 72

Resist CR with low friction seal and ball chain R1665 xxx 73

Preload Class

C0 = without Preload

C1 = Preload 2% C

Size	Accuracy Class	Part numbers for runner blocks for preload class	
		C0	C1
15	N	R1666 194 20	R1666 114 20
	H	R1666 193 20	R1666 113 20
20	N	R1666 894 20	R1666 814 20
	H	R1666 893 20	R1666 813 20
25	N	R1666 294 20	R1666 214 20
	H	R1666 293 20	R1666 213 20
30	N	R1666 794 20	R1666 714 20
	H	R1666 793 20	R1666 713 20
35	N	R1666 394 20	R1666 314 20
	H	R1666 393 20	R1666 313 20

Size	Accuracy Class	Part numbers for runner blocks for preload class	
		C0	C1
15	H	R2010 193 30	
20	H	R2010 893 30	
25	H	R2010 293 30	
30	H	R2010 793 30	R2010 713 30
35	H	R2010 393 30	R2010 313 30

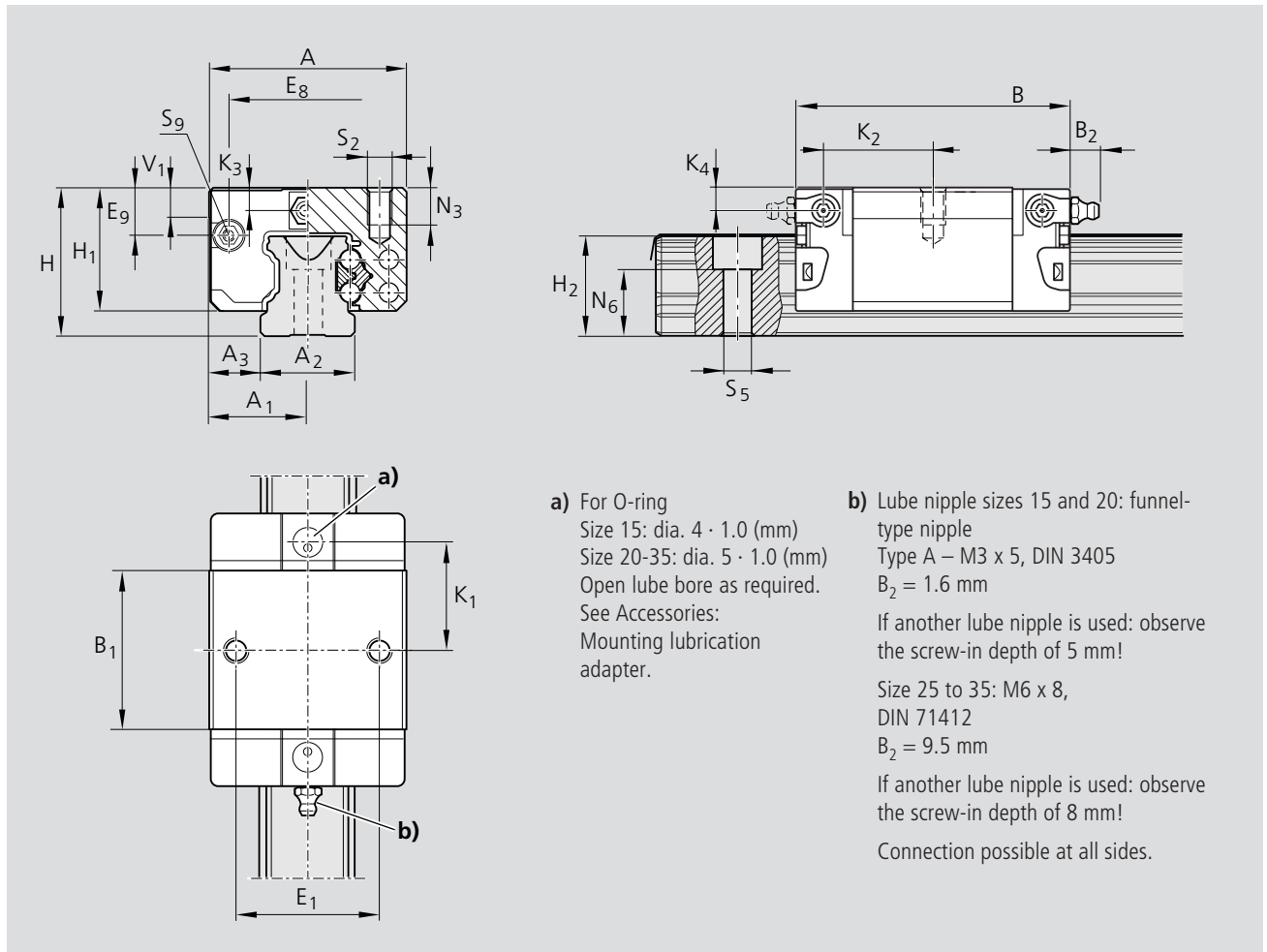

- a) For O-ring
 Size 15: dia. 4 · 1.0 (mm)
 Size 20-35: dia. 5 · 1.0 (mm)
 Open lube bore as required.
 See Accessories:
 Mounting lubrication adapter.
- b) Lube nipple sizes 15 and 20: funnel-type nipple
 Type A – M3 x 5, DIN 3405
 B₂ = 1.6 mm
 If another lube nipple is used: observe the screw-in depth of 5 mm!
 Size 25 to 35: M6 x 8,
 DIN 71412
 B₂ = 9.5 mm
 If another lube nipple is used: observe the screw-in depth of 8 mm!
 Connection possible at all sides.

Dimensions (mm)																		
Size	A	A ₁	A ₂	A ₃	B	B ₁	H	H ₁	H ₂ ¹⁾	H ₂ ²⁾	V ₁	E ₁	E ₈	E ₉	K ₁	K ₂	K ₃	K ₄
15	34	17	15	9.5	44.7	25.7	24	19.90	16.30	16.20	5.0	26	24.55	6.70	16.25	17.85	3.20	3.20
20	44	22	20	12.0	57.3	31.9	30	25.35	20.75	20.55	6.0	32	32.50	7.30	22.95	22.95	3.35	3.35
25	48	24	23	12.5	67.0	38.6	36	29.90	24.45	24.25	7.5	35	38.30	11.50	25.35	26.50	5.50	5.50
30	60	30	28	16.0	75.3	45.0	42	35.35	28.55	28.35	7.0	40	48.40	14.60	28.80	30.50	6.05	6.05
35	70	35	34	18.0	84.9	51.4	48	40.40	32.15	31.85	8.0	50	58.00	17.35	32.70	34.20	6.90	6.90

¹⁾ Dimension H₂ with rail seal cover strip

²⁾ Dimension H₂ without rail seal cover strip

Size	Dimensions (mm)					Mass (kg)	Load capacities (N) ³⁾				Moments (Nm)	
	N ₃	N ₆ ^{±0.5}	S ₂	S ₅	S ₉		C dyn.	C ₀ stat.	M _t dyn.	M _{t0} stat.	M _L dyn.	M _{L0} stat.
15	6.0	10.3	M4	4.4	M2.5-3.5 deep	0.10	6 800	8 100	52	80	19	28
20	7.5	13.2	M5	6.0	M3-5 deep	0.25	12 400	13 600	150	170	52	58
25	9.0	15.2	M6	7.0	M3-5 deep	0.35	15 800	18 200	230	260	82	94
30	12.0	17.0	M8	9.0	M3-5 deep	0.60	22 100	24 800	380	430	133	150
35	13.0	20.5	M8	9.0	M3-5 deep	0.90	29 300	32 400	640	700	200	220

³⁾ Load capacities for version without ball chain. Load capacities for version without ball chain, see Product Overview with Load Capacities. Determination of the dynamic of the load capacities and moments is based on 100,000 m of stroke travel. Often only 50,000 m are actually stipulated. Comparison: Value C, M_t and M_L per table multiplied by 1.26.

Standard Runner Blocks, Steel Version

Runner Block SNH R1621

Slimline High

- Runner block without ball chain:
for part numbers, see table
- Runner block with low friction seal without ball chain^{**}:
Part numbers R1621 xxx 21
- Runner block with ball chain:
Part numbers R1621 xxx 22
- Runner block with low friction seal and ball chain^{**}:
Part numbers R1621 xxx 23

Dynamic characteristics

Speed $v_{max} = 5 \text{ m/s}$
 Acceleration $a_{max} = 500 \text{ m/s}^2$

Precision Runner Block

- Pre-lubricated

Corrosion resistant Custom version

Resist CR – Runner Block housing chromium-plated matt silver

- Pre-lubricated

Delivery only in precision class H:

Sizes 15, 25 only without preload
 Sizes 30, 35, 45 only without preload or 2%C preload

High Precision Runner Blocks

- Further improved movement accuracy
- Superior quality
- Highest precision
- Pre-lubricated
- Minimal oil preservation

Preload Class

C0 = without Preload
 C1 = Preload 2% C
 C2 = Preload 8% C
 C3 = Preload 13% C

For further technical information, please see chapter on "General Technical Data and Calculations".

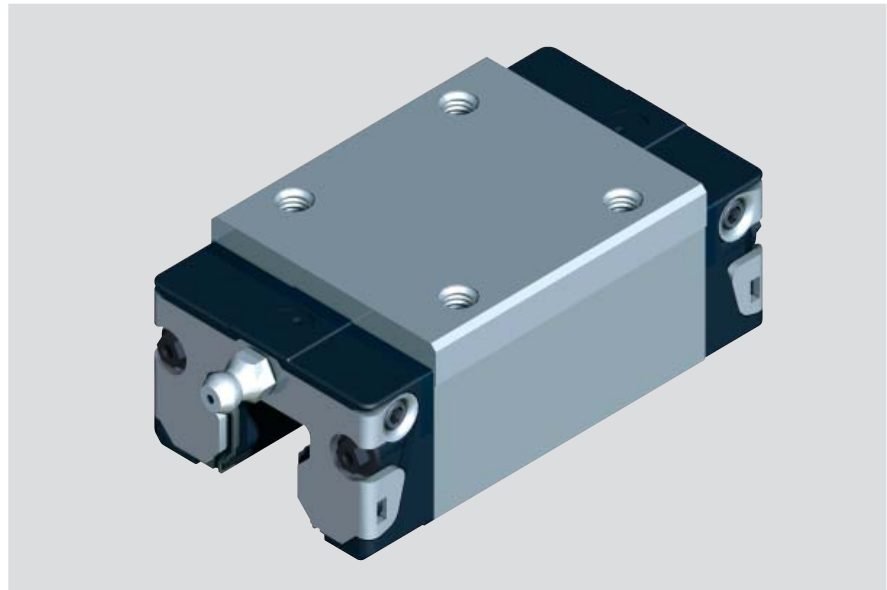

Size	Accuracy Class	Part numbers for runner blocks for preload class		
		C0	C1	C2
15	N	R1621 194 20	R1621 114 20	R1621 124 20
	H	R1621 193 20	R1621 113 20	R1621 123 20
	P		R1621 112 20	R1621 122 20
25	N	R1621 294 20	R1621 214 20	R1621 224 20
	H	R1621 293 20	R1621 213 20	R1621 223 20
	P		R1621 212 20	R1621 222 20
30	N	R1621 794 20	R1621 714 20	R1621 724 20
	H	R1621 793 20	R1621 713 20	R1621 723 20
	P		R1621 712 20	R1621 722 20
35	N	R1621 394 20	R1621 314 20	R1621 324 20
	H	R1621 393 20	R1621 313 20	R1621 323 20
	P		R1621 312 20	R1621 322 20
45*	N	R1621 494 20	R1621 414 20	R1621 424 20
	H	R1621 493 20	R1621 413 20	R1621 423 20
	P		R1621 412 20	R1621 422 20

Size	Accuracy Class	Part numbers for runner blocks for preload class		
		C1	C2	C3
15	XP	R1621 118 20	R1621 128 20	R1621 138 20
25	XP	R1621 218 20	R1621 228 20	R1621 238 20
30	XP	R1621 718 20	R1621 728 20	R1621 738 20
35	XP	R1621 318 20	R1621 328 20	R1621 338 20
45*	XP	R1621 418 20	R1621 428 20	R1621 438 20

* No delivery with low friction seal

** Delivery of low friction seal in preloads for C0 and C1 (only for precision classes N, H, XP)

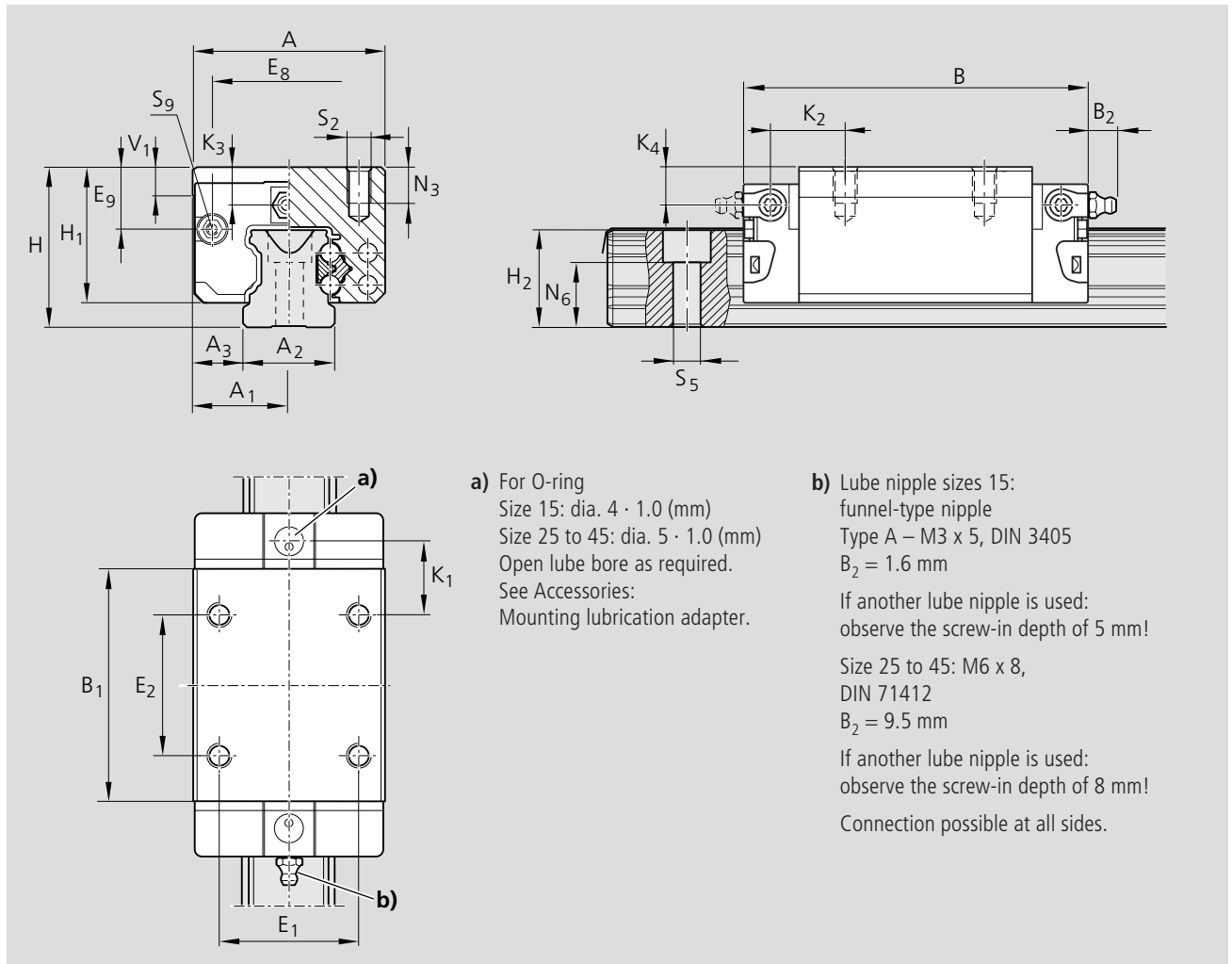

a) For O-ring
 Size 15: dia. 4 · 1.0 (mm)
 Size 25 to 45: dia. 5 · 1.0 (mm)
 Open lube bore as required.
 See Accessories:
 Mounting lubrication adapter.

b) Lube nipple sizes 15:
 funnel-type nipple
 Type A – M3 x 5, DIN 3405
 B₂ = 1.6 mm
 If another lube nipple is used:
 observe the screw-in depth of 5 mm!
 Size 25 to 45: M6 x 8,
 DIN 71412
 B₂ = 9.5 mm
 If another lube nipple is used:
 observe the screw-in depth of 8 mm!
 Connection possible at all sides.

Dimensions (mm)																			
Size	A	A ₁	A ₂	A ₃	B	B ₁	H	H ₁	H ₂ ¹⁾	H ₂ ²⁾	V ₁	E ₁	E ₂	E ₈	E ₉	K ₁	K ₂	K ₃	K ₄
15	34	17	15	9.5	58.2	39.2	28	23.90	16.30	16.20	5.0	26	26	24.55	10.70	10.00	11.60	7.20	7.20
25	48	24	23	12.5	86.2	57.8	40	33.90	24.45	24.25	7.5	35	35	38.30	15.50	17.45	18.60	9.50	9.50
30	60	30	28	16.0	97.7	67.4	45	38.35	28.55	28.35	7.0	40	40	48.40	17.60	20.00	21.70	9.05	9.05
35	70	35	34	18.0	110.5	77.0	55	47.40	32.15	31.85	8.0	50	50	58.00	24.35	20.50	22.00	13.90	13.90
45	86	43	45	20.5	137.6	97.0	70	60.30	40.15	39.85	10.0	60	60	69.80	30.90	27.30	29.30	18.20	18.20

¹⁾ Dimension H₂ with rail seal cover strip

²⁾ Dimension H₂ without rail seal cover strip

Size	N ₃	Dimensions (mm)				Mass (kg)	Load capacities (N) ³⁾				Moments (Nm)			
		N ₆ ^{±0.5}	S ₂	S ₅	S ₉		C dyn.	C ₀ stat.	M _t dyn.	M _{t0} stat.	M _L dyn.	M _{L0} stat.		
15	6.0	10.3	M4	4.4	M2.5-3.5 deep	0.20	7 800	13 500	74	130	40	71		
25	9.0	15.2	M6	7.0	M3-5 deep	0.60	22 800	30 400	320	430	180	240		
30	12.0	17.0	M8	9.0	M3-5 deep	0.95	31 700	41 300	540	720	290	380		
35	13.0	20.5	M8	9.0	M3-5 deep	1.55	41 900	54 000	890	1 160	440	565		
45	18.0	23.5	M10	14.0	M4-7 deep	3.00	68 100	85 700	1 830	2 310	890	1 130		

³⁾ Load capacities for version without ball chain. Load capacities for version without ball chain, see Product Overview with Load Capacities. Determination of the dynamic of the load capacities and moments is based on 100,000 m of stroke travel. Often only 50,000 m are actually stipulated. Comparison: Value C, M_t and M_L per table multiplied by 1.26.

Standard Runner Blocks, Steel Version

Runner Block SNH R1621

Slimline High

– Runner block without ball chain:
for part numbers, see table

Dynamic characteristics

Speed $v_{max} = 3 \text{ m/s}$
 Acceleration $a_{max} = 250 \text{ m/s}^2$
 Calculations

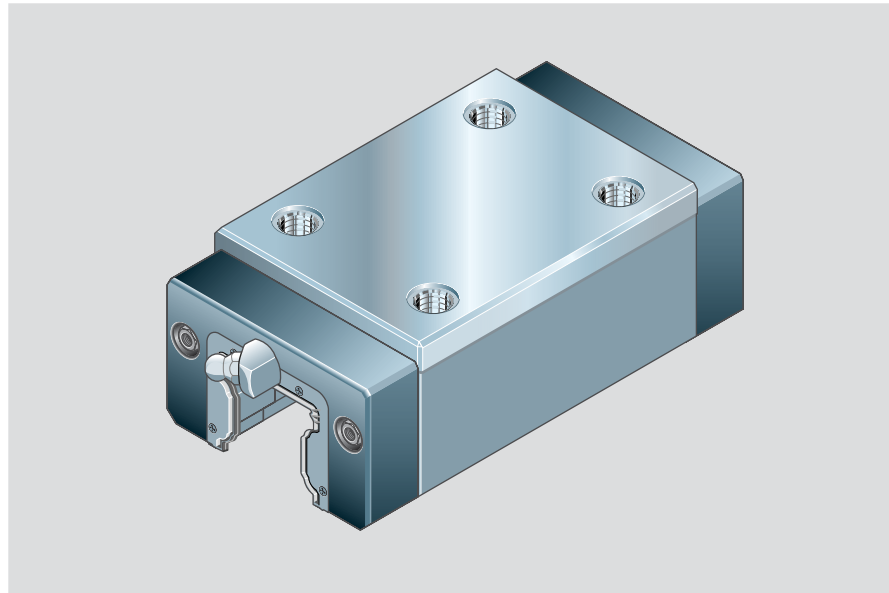

Precision Runner Block

– Not Pre-lubricated

Size	Accuracy Class	Part numbers for runner blocks for preload class			
		C0	C1	C2	C3
55	N	R1621 594 10	R1621 514 10	R1621 524 10	
	H	R1621 593 10	R1621 513 10	R1621 523 10	
	P		R1621 512 10	R1621 522 10	R1621 532 10

Corrosion resistant Custom version

Resist CR – Chromium-plated matt silver
runner block housing

– Not Pre-lubricated

Size	Accuracy Class	Part numbers for runner blocks for preload class	
		C0	C1
55	H	R1621 593 60	R1621 513 60

Preload Class

- C0 = without Preload
- C1 = Preload 2% C
- C2 = Preload 8% C
- C3 = Preload 13% C

For further technical information, please see chapter on "General Technical Data and Calculations".

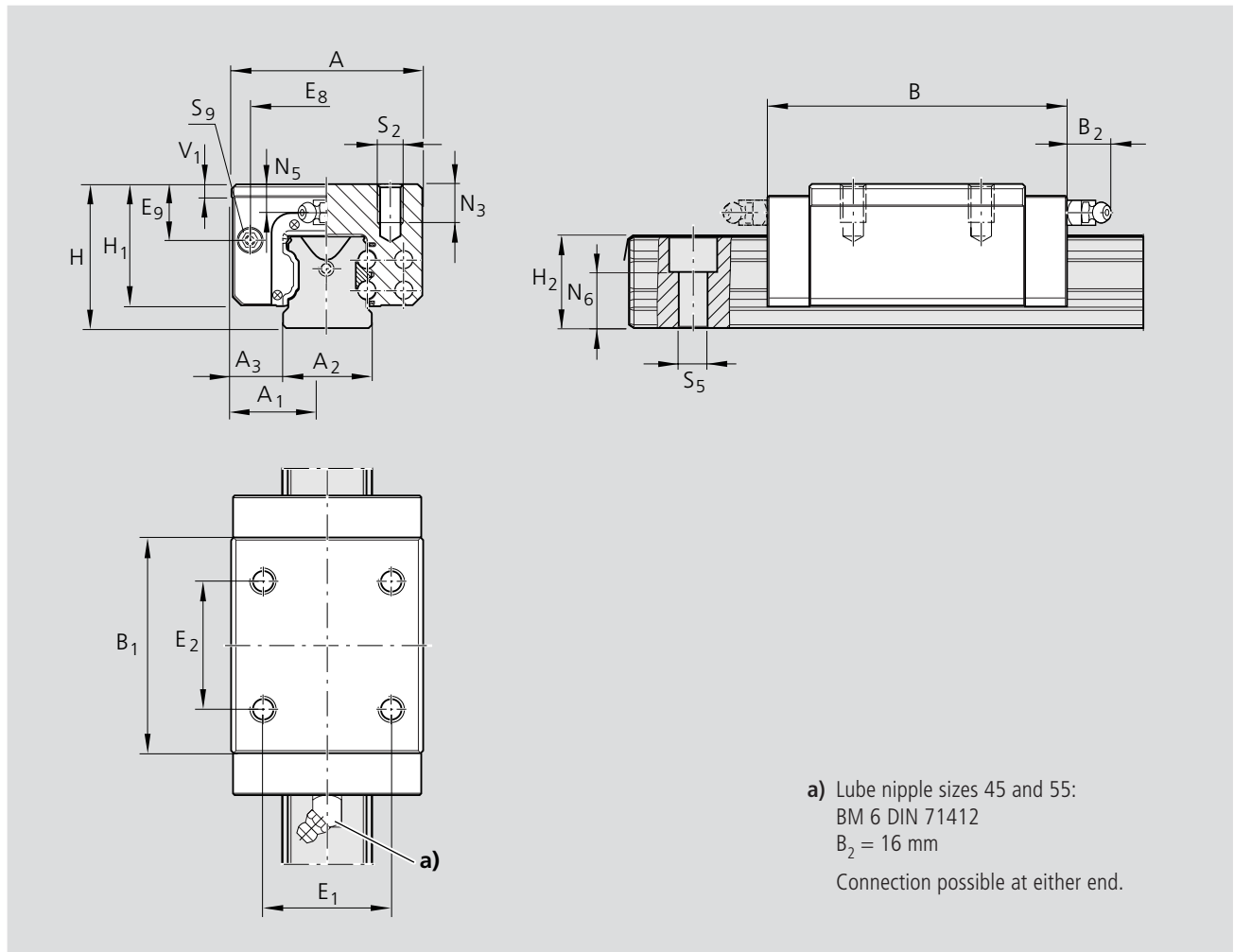

Size	Dimensions (mm)															
	A	A ₁	A ₂	A ₃	B	B ₁	H	H ₁	H ₂ ¹⁾	H ₂ ²⁾	V ₁	E ₁	E ₂	E ₈	E ₉	N ₃
55	100	50	53	23.5	159.0	115.5	80	67.0	48.15	47.85	12.0	75	75	80.0	32.3	19

¹⁾ Dimension H₂ with rail seal cover strip

²⁾ Dimension H₂ without rail seal cover strip

Size	Dimensions (mm)					Mass (kg)	Load capacities (N) ³⁾				Moments (Nm)	
	N ₅	N ₆ ^{±0.5}	S ₂	S ₅	S ₉		C dyn.	C ₀ stat.	M _t dyn.	M _{t0} stat.	M _L dyn.	M _{L0} stat.
55	19.0	29.0	M12	16.0	M5-8 deep	4.70	98 200	121 400	3 100	3 860	1 540	1 905

³⁾ Load capacities for version without ball chain. Load capacities for version without ball chain, see Product Overview with Load Capacities. Determination of the dynamic of the load capacities and moments is based on 100,000 m of stroke travel. Often only 50,000 m are actually stipulated. Comparison: Value C, M_L und M_L per table multiplied by 1.26.

Standard Runner Blocks, Steel Version

Runner Block SLH R1624

Slimline Long High

- Runner block without ball chain:
for part numbers, see table
- Runner block with low friction seal
without ball chain:**:
Part numbers R1624 xxx 21
- Runner block with ball chain:
Part numbers R1624 xxx 22
- Runner block with low friction seal and
ball chain:**:
Part numbers R1624 xxx 23

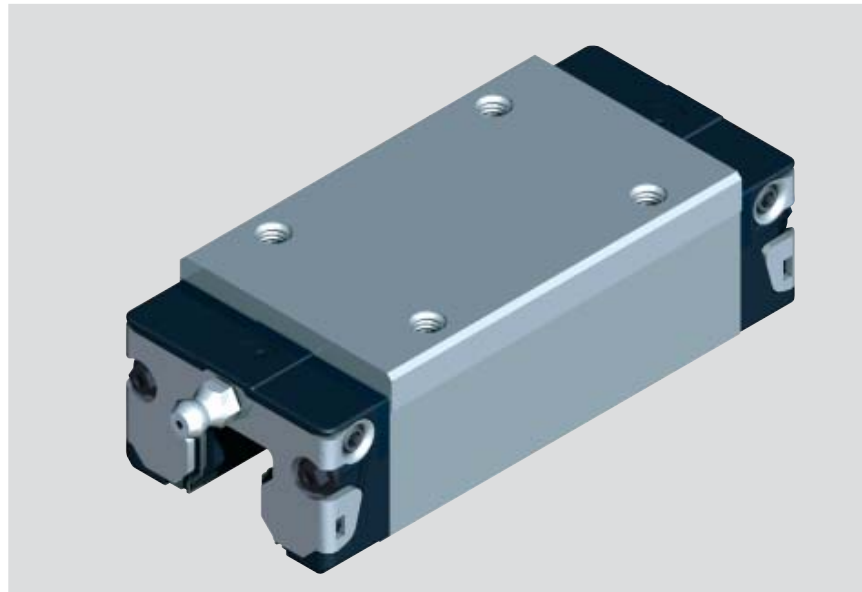

Dynamic characteristics

Speed $v_{max} = 5 \text{ m/s}$
 Acceleration $a_{max} = 500 \text{ m/s}^2$

Precision Runner Blocks

- Pre-lubricated

Corrosion resistant Custom version

Resist CR – Chromium-plated matt silver
runner block housing

- Pre-lubricated

Delivery only in precision class H:

Size 25 only without preload
 Sizes 30, 35, 45 only without preload or
 2%C preload

Size	Accuracy Class	Part numbers for runner blocks for preload class		
		C0	C1	C2
25	N	R1624 294 20	R1624 214 20	R1624 224 20
	H	R1624 293 20	R1624 213 20	R1624 223 20
	P		R1624 212 20	R1624 222 20
30	N	R1624 794 20	R1624 714 20	R1624 724 20
	H	R1624 793 20	R1624 713 20	R1624 723 20
	P		R1624 712 20	R1624 722 20
35	N	R1624 394 20	R1624 314 20	R1624 324 20
	H	R1624 393 20	R1624 313 20	R1624 323 20
	P		R1624 312 20	R1624 322 20
45*	N	R1624 494 20	R1624 414 20	R1624 424 20
	H	R1624 493 20	R1624 413 20	R1624 423 20
	P		R1624 412 20	R1624 422 20

High Precision Runner Blocks

- Improved travel accuracy
- Superior quality
- Highest precision
- Pre-lubricated
- Minimal oil preservation

Size	Accuracy Class	Part numbers for runner blocks for preload class		
		C1	C2	C3
25	XP	R1624 218 20	R1624 228 20	R1624 238 20
30	XP	R1624 718 20	R1624 728 20	R1624 738 20
35	XP	R1624 318 20	R1624 328 20	R1624 338 20
45*	XP	R1624 418 20	R1624 428 20	R1624 438 20

* No delivery with low friction seal

** Low friction seal available for C0 and C1
(only for precision classes N, H, XP)

Preload Class

C0 = without Preload
 C1 = Preload 2% C
 C2 = Preload 8% C
 C3 = Preload 13% C

For further technical information, please
 see chapter on "General Technical Data
 and Calculations".

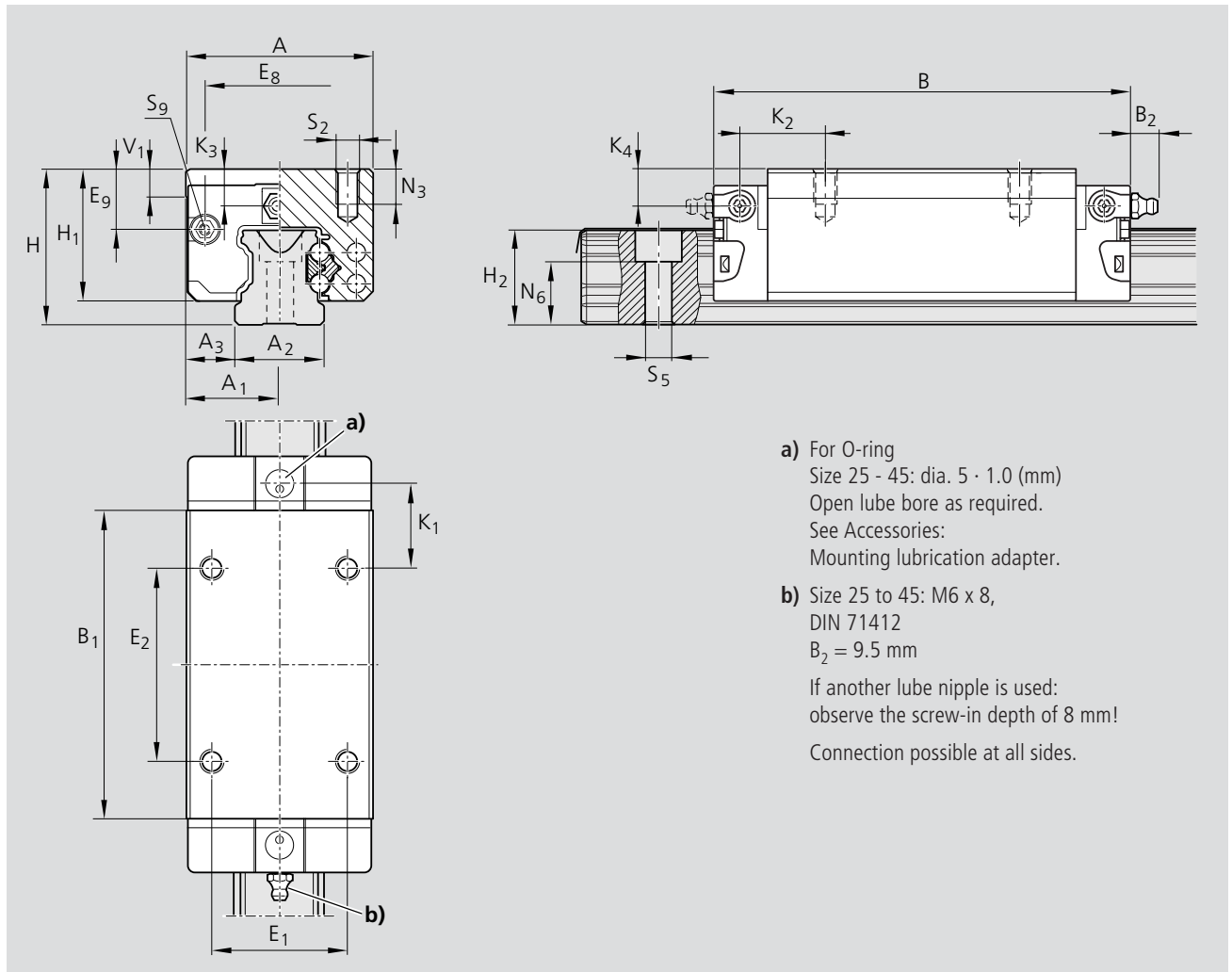

- a) For O-ring
Size 25 - 45: dia. 5 · 1.0 (mm)
Open lube bore as required.
See Accessories:
Mounting lubrication adapter.
- b) Size 25 to 45: M6 x 8,
DIN 71412
B₂ = 9.5 mm
If another lube nipple is used:
observe the screw-in depth of 8 mm!
Connection possible at all sides.

Dimensions (mm)																			
Size	A	A ₁	A ₂	A ₃	B	B ₁	H	H ₁	H ₂ ¹⁾	H ₂ ²⁾	V ₁	E ₁	E ₂	E ₈	E ₉	K ₁	K ₂	K ₃	K ₄
25	48	24	23	12.5	107.9	79.5	40	33.90	24.45	24.25	7.5	35	50	38.30	15.50	20.80	21.95	9.50	9.50
30	60	30	28	16.0	119.7	89.4	45	38.35	28.55	28.35	7.0	40	60	48.40	17.60	21.00	22.70	9.05	9.05
35	70	35	34	18.0	139.0	105.5	55	47.40	32.15	31.85	8.0	50	72	58.00	24.35	23.75	25.25	13.90	13.90
45	86	43	45	20.5	174.1	133.5	70	60.30	40.15	39.85	10.0	60	80	69.80	30.90	35.50	37.50	18.20	18.20

¹⁾ Dimension H₂ with rail seal cover strip

²⁾ Dimension H₂ without rail seal cover strip

Size	Dimensions (mm)						Mass (kg)	Load capacities (N) ³⁾				Moments (Nm)	
	N ₃	N ₆ ^{±0.5}	S ₂	S ₅	S ₉	C dyn.		C ₀ stat.	M _t dyn.	M _{t0} stat.	M _L dyn.	M _{L0} stat.	
25	9.0	15.2	M6	7.0	M3-5 deep	0.80	30 400	45 500	430	650	345	510	
30	12.0	17.0	M8	9.0	M3-5 deep	1.20	40 000	57 800	690	1 000	495	715	
35	13.0	20.5	M8	9.0	M3-5 deep	2.10	55 600	81 000	1 200	1 740	830	1 215	
45	18.0	23.5	M10	14.0	M4-7 deep	4.10	90 400	128 500	2 440	3 470	1 700	2 425	

³⁾ Load capacities for version without ball chain. Load capacities for version without ball chain, see Product Overview with Load Capacities. Determination of the dynamic of the load capacities and moments is based on 100,000 m of stroke travel. Often only 50,000 m are actually stipulated. Comparison: Value C, M_t and M_L per table multiplied by 1.26.

Standard Runner Blocks, Steel Version

Runner Block SLH R1624

Slimline Long High

- Runner block without ball chain:
for part numbers, see table

Dynamic characteristics

Speed $v_{max} = 3 \text{ m/s}$
 Acceleration $a_{max} = 250 \text{ m/s}^2$

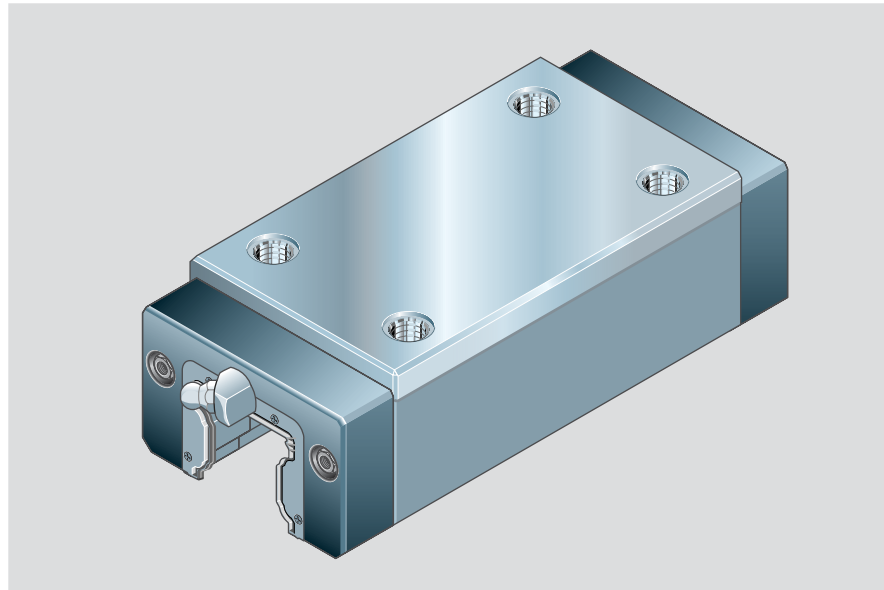

Precision Runner Blocks

- Not Pre-lubricated

Size	Accuracy Class	Part numbers for runner blocks for preload class			
		C0	C1	C2	C3
55	N	R1624 594 10	R1624 514 10	R1624 524 10	
	H	R1624 593 10	R1624 513 10	R1624 523 10	
	P		R1624 512 10	R1624 522 10	R1624 532 10

Corrosion resistant Custom version

Resist CR – Runner Block housing chromium-plated matt silver

- Not Pre-lubricated

Size	Accuracy Class	Part numbers for runner blocks for preload class	
		C0	C1
55	H	R1624 593 60	R1624 513 60

Preload Class

- C0 = without Preload
- C1 = Preload 2% C
- C2 = Preload 8% C
- C3 = Preload 13% C

For further technical information, please see chapter on "General Technical Data and Calculations".

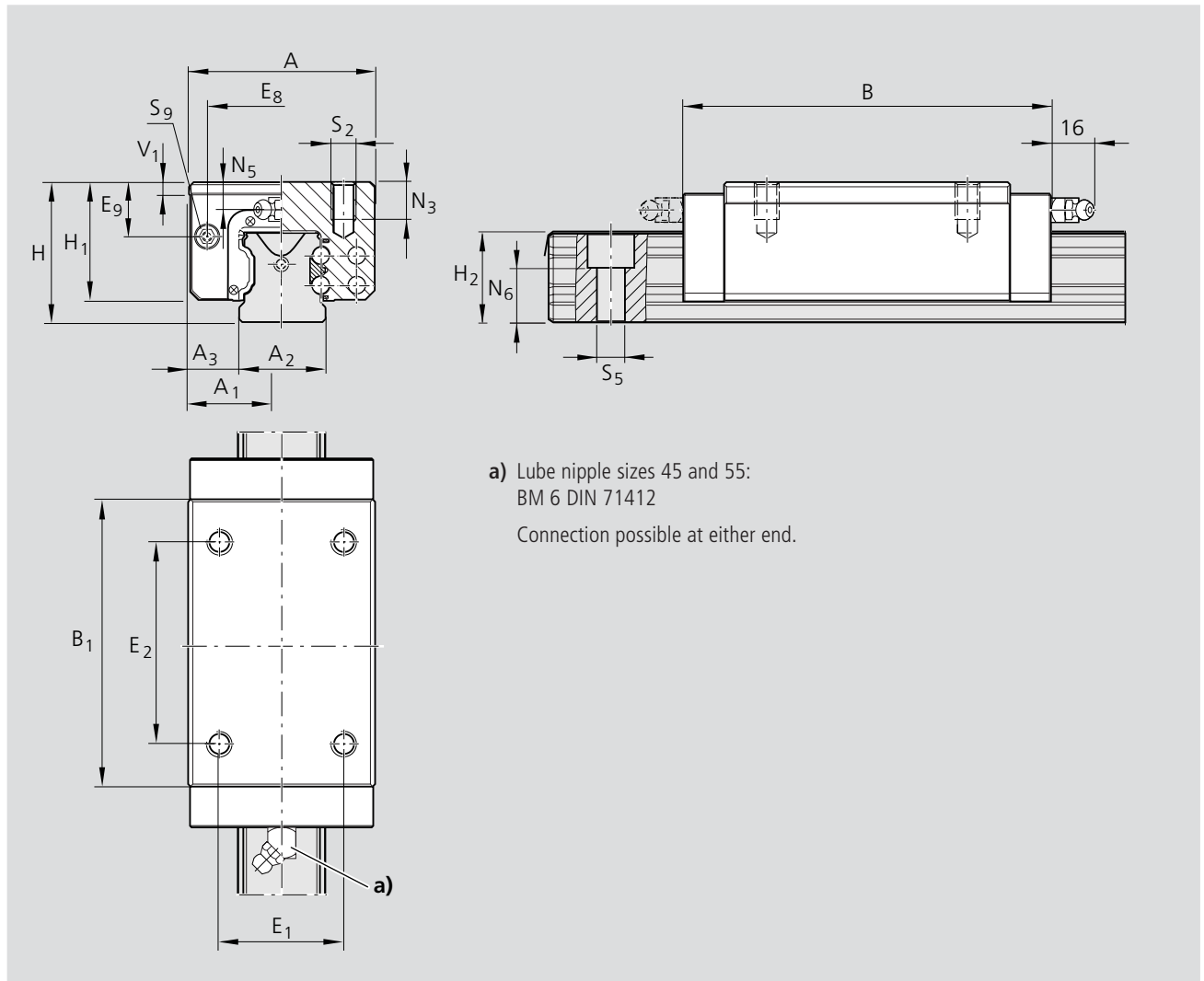

a) Lube nipple sizes 45 and 55:
 BM 6 DIN 71412
 Connection possible at either end.

Size	Dimensions (mm)															
	A	A ₁	A ₂	A ₃	B	B ₁	H	H ₁	H ₂ ¹⁾	H ₂ ²⁾	V ₁	E ₁	E ₂	E ₈	E ₉	N ₃
55	100	50	53	23.5	200	155.5	80	67.0	48.15	47.85	12.0	75	95	80.0	32.3	19

¹⁾ Dimension H₂ with rail seal cover strip

²⁾ Dimension H₂ without rail seal cover strip

Size	Dimensions (mm)					Mass (kg)	Load capacities (N) ³⁾				Moments (Nm)	
	N ₅	N ₆ ^{±0.5}	S ₂	S ₅	S ₉		C dyn.	C ₀ stat.	M _t dyn.	M _{t0} stat.	M _L dyn.	M _{L0} stat.
55	19.0	29.0	M12	16.0	M5-8 deep	6.00	124 200	170 000	3 950	5 400	2 630	3 600

³⁾ Load capacities for version without ball chain. Load capacities for version without ball chain, see Product Overview with Load Capacities. Determination of the dynamic of the load capacities and moments is based on 100,000 m of stroke travel. Often only 50,000 m are actually stipulated. Comparison: Value C, M_t and M_L per table multiplied by 1.26.

Low Profile Runner Blocks, Steel Version

Runner Block FNN R1693

Flange Standard, Low Profile

- Runner block without ball chain:
for part numbers, see table
- Runner block with low friction seal
without ball chain:
Part numbers R1693 xxx 11

Dynamic characteristics

Speed $v_{max} = 3 \text{ m/s}$
 Acceleration $a_{max} = 250 \text{ m/s}^2$

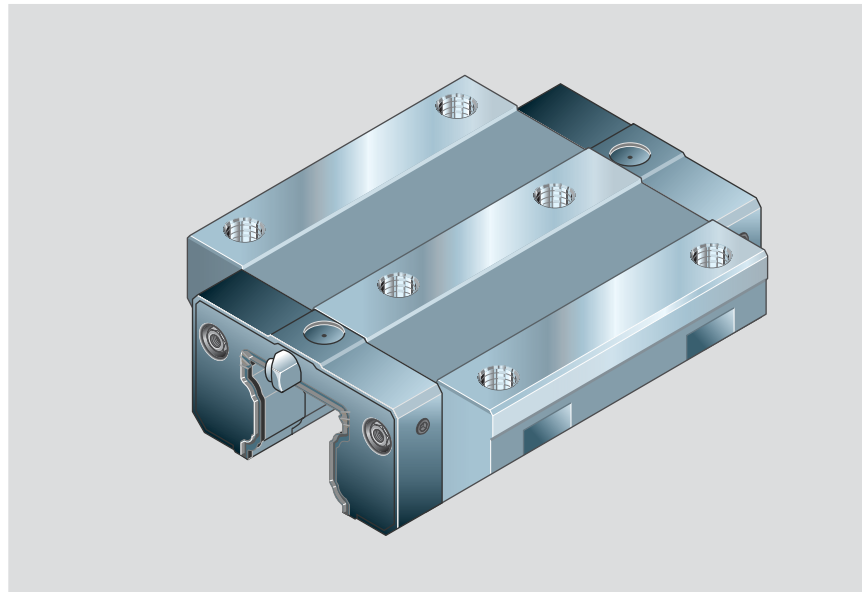

Precision Runner Blocks

- Not Pre-lubricated

Size	Accuracy Class	Part numbers for runner blocks for preload class	
		C0	C1
20	N	R1693 894 10	R1693 814 10
	H	R1693 893 10	R1693 813 10
25	N	R1693 294 10	R1693 214 10
	H	R1693 293 10	R1693 213 10

Corrosion resistant Custom version

Resist CR – Runner Block housing
chromium-plated matt silver

- Not Pre-lubricated

Size	Accuracy Class	Part numbers for runner blocks for preload class
		C0
20	H	R1693 893 60
25	H	R1693 293 60

Preload Class

C0 = without Preload
 C1 = Preload 2% C

For further technical information, please see chapter on "General Technical Data and Calculations".

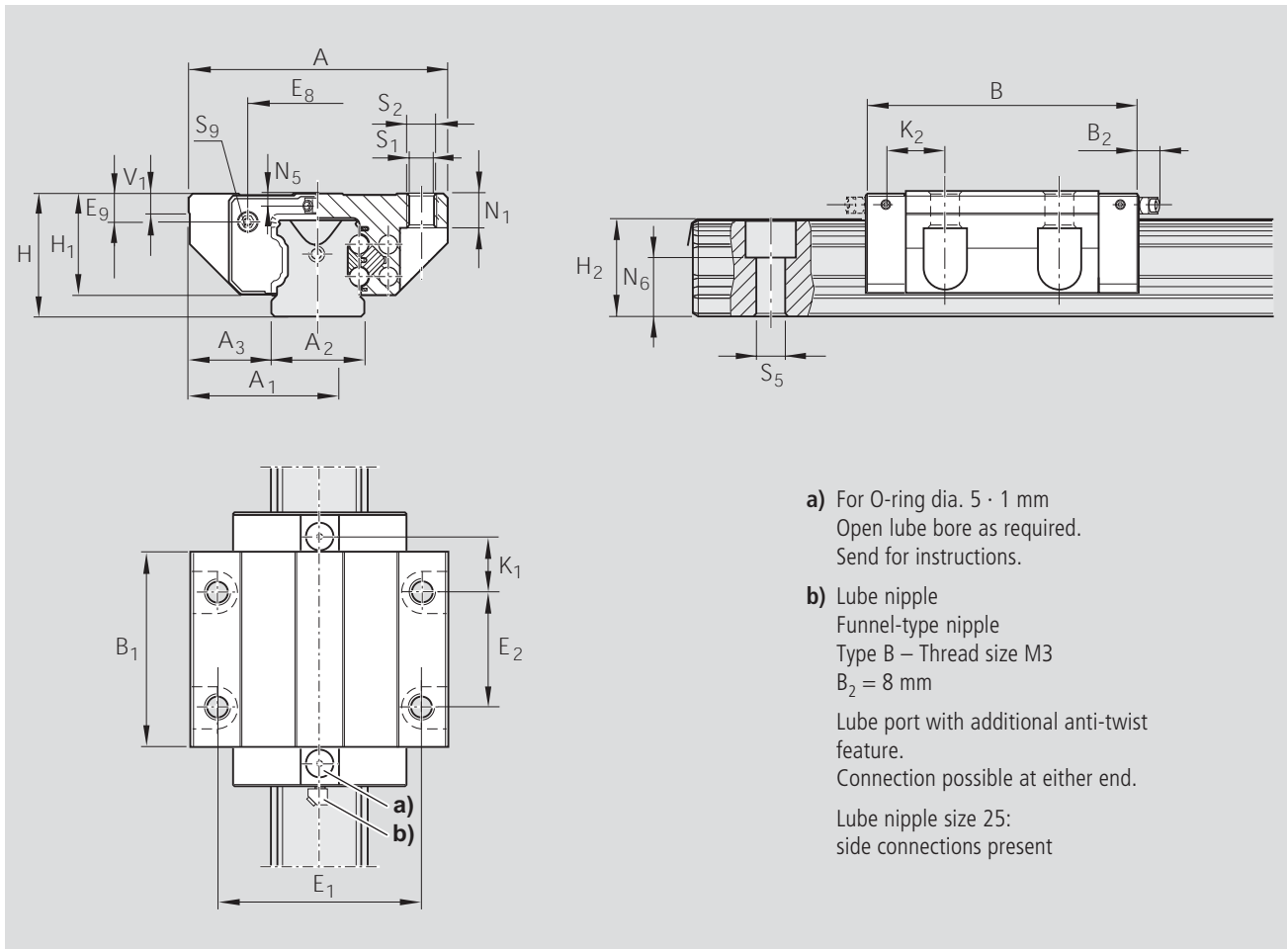

- a) For O-ring dia. 5 · 1 mm
Open lube bore as required.
Send for instructions.
- b) Lube nipple
Funnel-type nipple
Type B – Thread size M3
B₂ = 8 mm
Lube port with additional anti-twist feature.
Connection possible at either end.
Lube nipple size 25:
side connections present

Dimensions (mm)																		
Size	A	A ₁	A ₂	A ₃	B	B ₁	H	H ₁	H ₂ ¹⁾	H ₂ ²⁾	V ₁	E ₁	E ₂	E ₈	E ₉	K ₁	K ₂	N ₁
20	59	29.5	20	19.5	72.5	49.6	28	23.0	20.7	20.55	6.0	49	32	30.5	5.6	13.0	–	7.7
25	73	36.5	23	25.0	81.0	57.8	33	26.5	24.4	24.25	7.5	60	35	38.3	8.5	16.6	17.0	9.3

¹⁾ Dimension H₂ with rail seal cover strip

²⁾ Dimension H₂ without rail seal cover strip.

Size	Dimensions (mm)							Mass (kg)	Load capacities (N) ³⁾				Moments (Nm)	
	N ₅	N ₆ ^{±0.5}	S ₁	S ₂	S ₅	S ₉	C		M _t		M _L			
							dyn.		C ₀ stat.	dyn.	M _{t0} stat.	dyn.	M _{L0} stat.	
20	3.6	13.2	5.4	M6	6.0	M3-5 deep	0.40	14 500	24 400	190	310	100	165	
25	4.1	15.2	6.8	M8	7.0	M3-5 deep	0.60	22 800	30 400	320	430	180	240	

³⁾ Load capacities for version without ball chain. Load capacities for version without ball chain, see Product Overview with Load Capacities. Determination of the dynamic of the load capacities and moments is based on 100,000 m of stroke travel. Often only 50,000 m are actually stipulated. Comparison: Value C, M_t and M_L per table multiplied by 1.26.

Low Profile Runner Blocks, Steel Version

Runner Block FKN R1663

Flange Short, Low Profile

- Runner block without ball chain:
for part numbers, see table
- Runner block with low friction seal
without ball chain:
Part numbers R1663 xxx 11

Dynamic characteristics

Speed	$v_{\max} = 3 \text{ m/s}$
Acceleration	$a_{\max} = 250 \text{ m/s}^2$

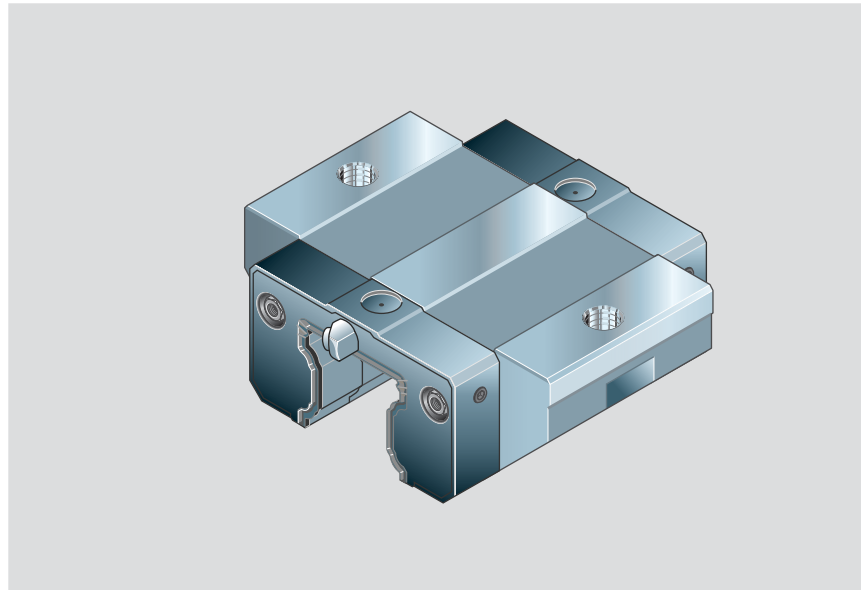

Precision Runner Block

- Not Pre-lubricated

Size	Accuracy Class	Part numbers for runner blocks for preload class	
		C0	C1
20	N	R1663 894 10	R1663 814 10
	H	R1663 893 10	R1663 813 10
25	N	R1663 294 10	R1663 214 10
	H	R1663 293 10	R1663 213 10

Corrosion resistant Custom version

Resist CR – Runner Block housing
chromium-plated matt silver

- Not Pre-lubricated

Size	Accuracy Class	Part numbers for runner blocks for preload class
		C0
20	H	R1663 893 60
25	H	R1663 293 60

Preload Class

- C0 = without Preload
- C1 = Preload 2% C
- C2 = Preload 8% C
- C3 = Preload 13% C

For further technical information, please see chapter on "General Technical Data and Calculations".

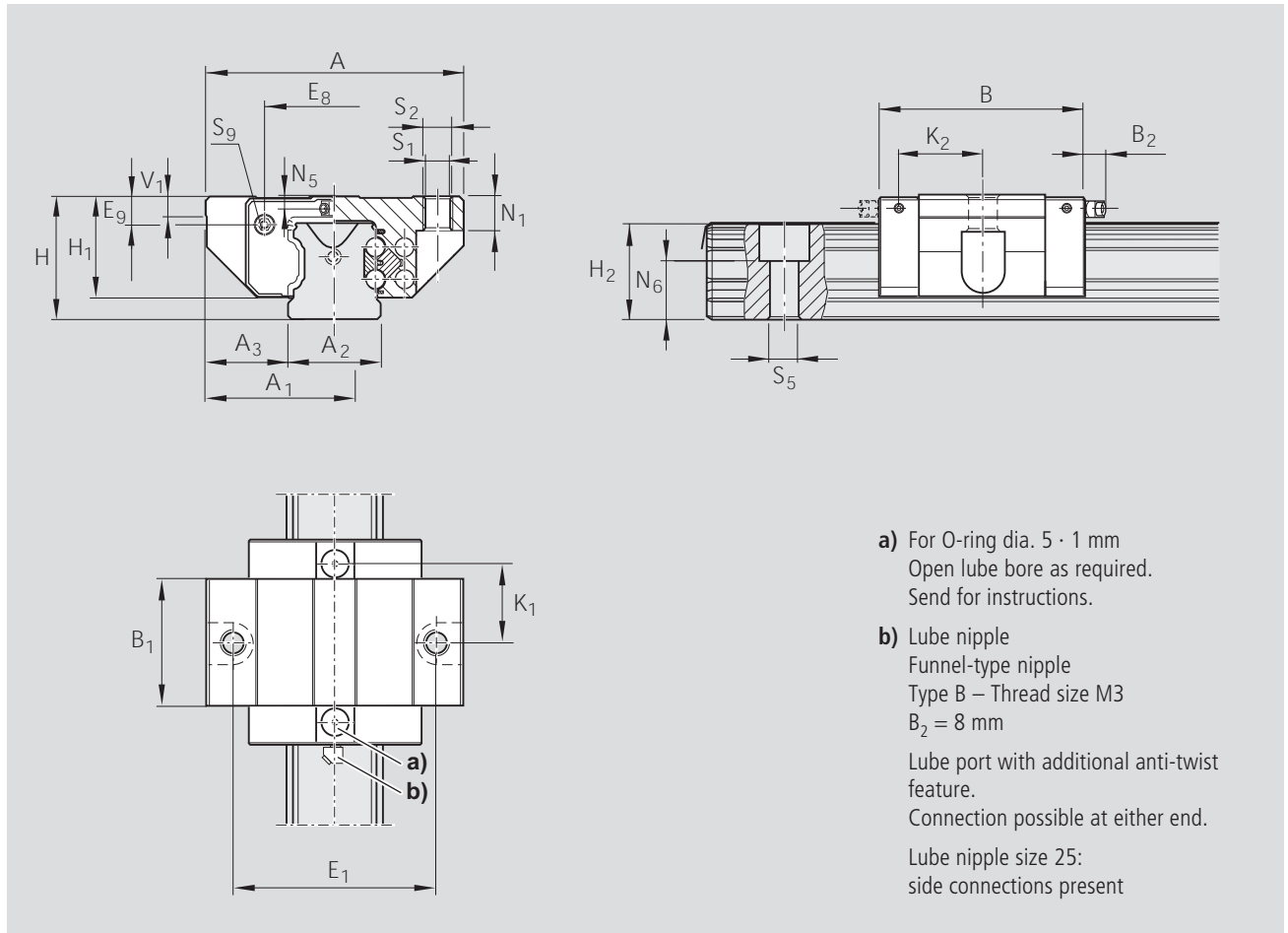

- a) For O-ring dia. 5 · 1 mm
Open lube bore as required.
Send for instructions.
- b) Lube nipple
Funnel-type nipple
Type B – Thread size M3
B₂ = 8 mm
Lube port with additional anti-twist feature.
Connection possible at either end.
Lube nipple size 25:
side connections present

Dimensions (mm)																		
Size	A	A ₁	A ₂	A ₃	B	B ₁	H	H ₁	H ₂ ¹⁾	H ₂ ²⁾	V ₁	E ₁	E ₈	E ₉	K ₁	K ₂	N ₁	N ₅
20	59	29.5	20	19.5	55	31.9	28	23.0	20.7	20.55	6.0	49	30.5	5.6	20.1	–	7.7	3.6
25	73	36.5	23	25.0	62	38.6	33	26.5	24.4	24.25	7.5	60	38.3	8.5	24.5	25.0	9.3	4.1

¹⁾ Dimension H₂ with rail seal cover strip

²⁾ Dimension H₂ without rail seal cover strip.

Size	N ₆ ^{±0.5}	Dimensions (mm)				Mass (kg)	Load capacities (N) ³⁾		Moments (Nm)			
		S ₁	S ₂	S ₅	S ₉		C dyn.	C ₀ stat.	M _t dyn.	M _{t0} stat.	M _L dyn.	M _{L0} stat.
20	13.2	5.4	M6	6.0	M3-5 deep	0.25	9 600	13 600	120	170	40	58
25	15.2	6.8	M8	7.0	M3-5 deep	0.45	15 900	18 200	235	260	82	94

³⁾ Load capacities for version without ball chain. Load capacities for version without ball chain, see Product Overview with Load Capacities. Determination of the dynamic of the load capacities and moments is based on 100,000 m of stroke travel. Often only 50,000 m are actually stipulated. Comparison: Value C, M_t und M_L per table multiplied by 1.26.

Low Profile Runner Blocks, Steel Version

Runner Block SNN R1694

Slimline Standard, Low Profile

- Runner block without ball chain: for part numbers, see table
- Runner block with low friction seal without ball chain: Part numbers R1694 xxx 11

Dynamic characteristics

Speed $v_{max} = 3 \text{ m/s}$
 Acceleration $a_{max} = 250 \text{ m/s}^2$

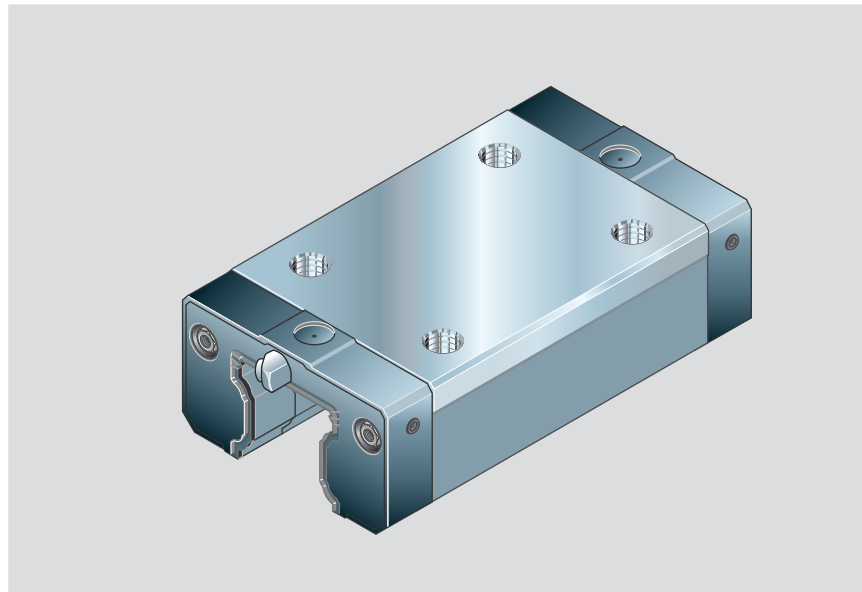

Precision Runner Blocks

- Not Pre-lubricated

Size	Accuracy Class	Part numbers for runner blocks for preload class	
		C0	C1
20	N	R1694 894 10	R1694 814 10
	H	R1694 893 10	R1694 813 10
25	N	R1694 294 10	R1694 214 10
	H	R1694 293 10	R1694 213 10

Corrosion resistant Custom version

Resist CR – Chromium-plated matt silver runner block housing

- Not Pre-lubricated

Size	Accuracy Class	Part numbers for runner blocks for preload class
		C0
20	H	R1694 893 60
25	H	R1694 293 60

Preload Class

C0 = without Preload

C1 = Preload 2% C

For further technical information, please see chapter on "General Technical Data and Calculations".

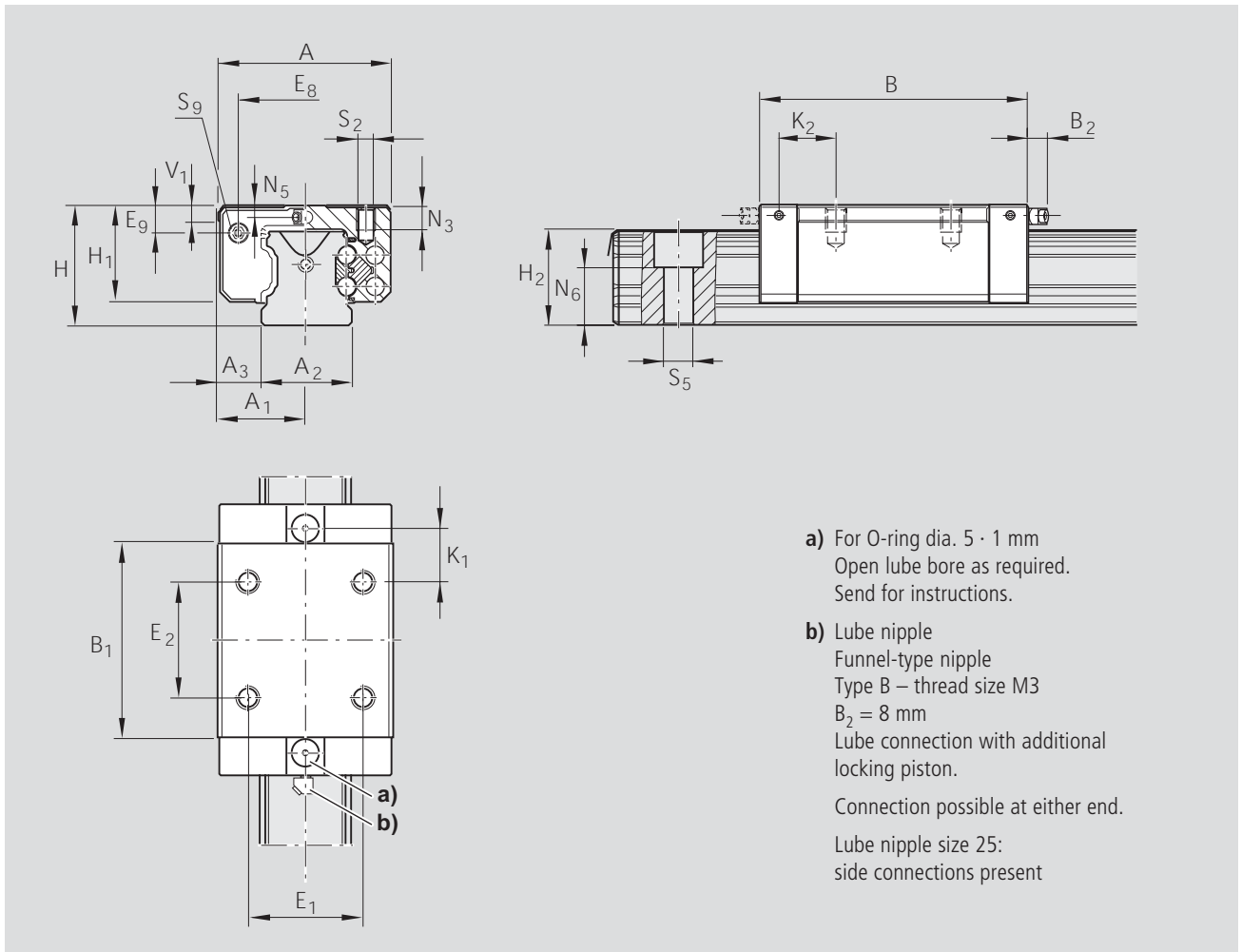

- a) For O-ring dia. 5 · 1 mm
Open lube bore as required.
Send for instructions.
- b) Lube nipple
Funnel-type nipple
Type B – thread size M3
B₂ = 8 mm
Lube connection with additional locking piston.
Connection possible at either end.
Lube nipple size 25:
side connections present

Dimensions (mm)																			
Size	A	A ₁	A ₂	A ₃	B	B ₁	H	H ₁	H ₂ ¹⁾	H ₂ ²⁾	V ₁	E ₁	E ₂	E ₈	E ₉	K ₁	K ₂	N ₃	
20	42	21	20	11.0	72.5	49.6	28	23.0	20.7	20.55	6.0	32	32	30.5	5.6	13.0	–	6.3	
25	48	24	23	12.5	81.0	57.8	33	26.5	24.4	24.25	7.5	35	35	38.3	8.5	16.6	17.0	7.0	

¹⁾ Dimension H₂ with rail seal cover strip

²⁾ Dimension H₂ without rail seal cover strip.

Size	Dimensions (mm)						Mass (kg)	Load capacities (N)		Moments (Nm)			
	N ₅	N ₆ ^{±0.5}	S ₂	S ₅	S ₉	C dyn.		C ₀ stat.	M _t dyn.	M _{t0} stat.	M _L dyn.	M _{L0} stat.	
20	3.6	13.2	M5	6.0	M3-5 deep	0.30	14 500	24 400	190	310	100	165	
25	4.1	5.2	M6	7.0	M3-5 deep	0.45	22 800	30 400	320	430	180	240	

³⁾ Load capacities for version without ball chain. Load capacities for version without ball chain, see Product Overview with Load Capacities. Determination of the dynamic of the load capacities and moments is based on 100,000 m of stroke travel. Often only 50,000 m are actually stipulated. Comparison: Value C, M_t und M_L per table multiplied by 1.26.

Low Profile Runner Blocks, Steel Version

Runner Block SKN R1664

Slimline Short, Low Profile

- Runner block without ball chain:
Part numbers, see table
- Runner block with low friction seal
without ball chain:
Part numbers R1664 xxx 11

Dynamic characteristics

Speed	$v_{\max} = 3 \text{ m/s}$
Acceleration	$a_{\max} = 250 \text{ m/s}^2$

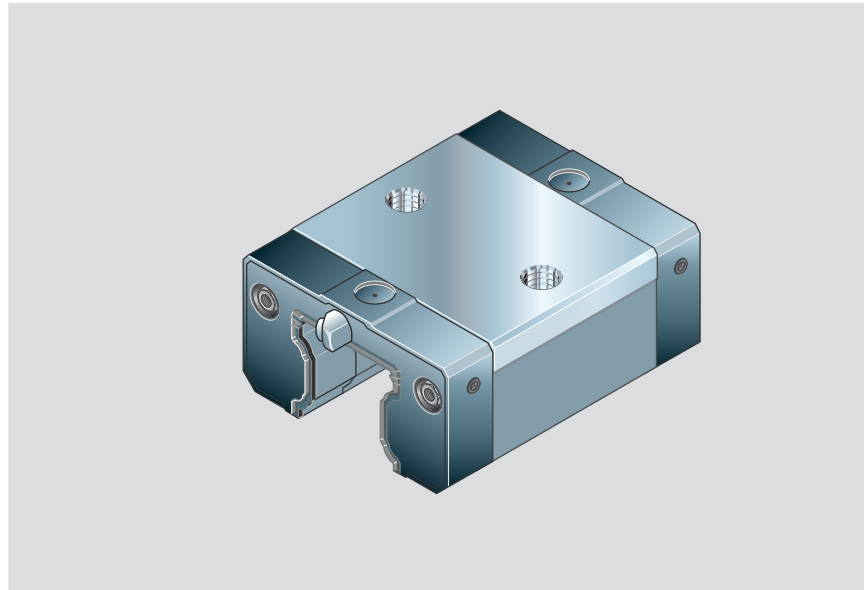

Precision Runner Blocks

- Not Pre-lubricated

Size	Accuracy Class	Part numbers for runner blocks for preload class	
		C0	C1
20	N	R1664 894 10	R1664 814 10
	H	R1664 893 10	R1664 813 10
25	N	R1664 294 10	R1664 214 10
	H	R1664 293 10	R1664 213 10

Corrosion resistant Custom version

Resist CR – Chromium-plated matt silver
runner block housing

- Not Pre-lubricated

Size	Accuracy Class	Part numbers for runner blocks for preload class
		C0
20	H	R1664 893 60
25	H	R1664 293 60

Preload Class

C0 = without Preload

C1 = Preload 2% C

For further technical information, please see chapter on "General Technical Data and Calculations".

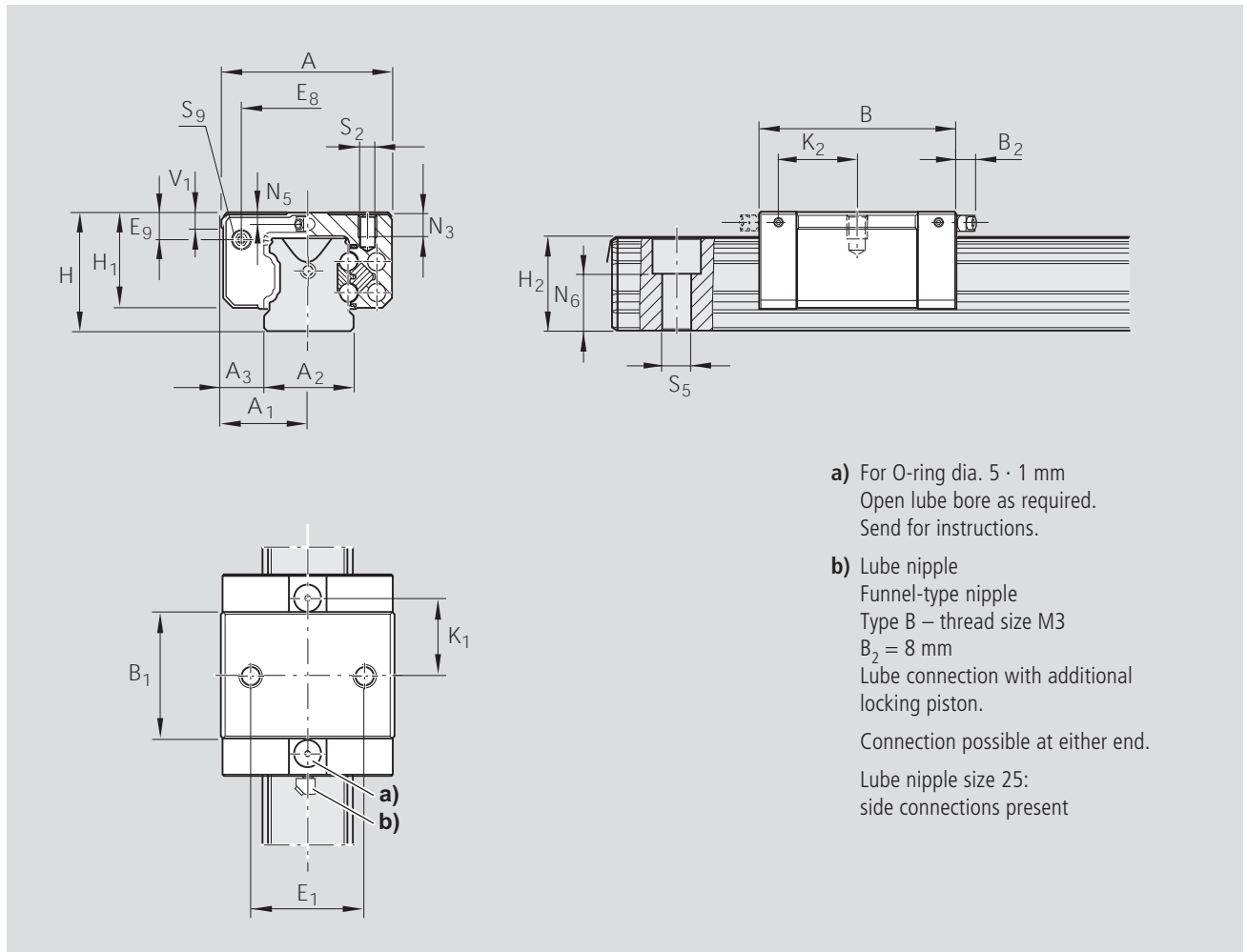

Dimensions (mm)																	
Size	A	A ₁	A ₂	A ₃	B	B ₁	H	H ₁	H ₂ ¹⁾	H ₂ ²⁾	V ₁	E ₁	E ₈	E ₉	K ₁	K ₂	N ₃
20	42	21	20	11.0	55	31.9	28	23.0	20.7	20.55	6.0	32	30.5	5.6	20.1	–	6.3
25	48	24	23	12.5	62	38.6	33	26.5	24.4	24.25	7.5	35	38.3	8.5	24.5	25.0	7.0

¹⁾ Dimension H₂ with rail seal cover strip

²⁾ Dimension H₂ without rail seal cover strip

Size	Dimensions (mm)					Mass (kg)	Load capacities (N) ³⁾		Moments (Nm)			
	N ₅	N ₆ ^{±0.5}	S ₂	S ₅	S ₉		C dyn.	C ₀ stat.	M _t dyn.	M _{t0} stat.	M _L dyn.	M _{L0} stat.
20	3.6	13.2	M5	6.0	M3-5 deep	0.20	9 600	13 600	120	170	40	58
25	4.1	15.2	M6	7.0	M3-5 deep	0.30	15 900	18 200	235	260	82	94

³⁾ Load capacities for version without ball chain. Load capacities for version without ball chain, see Product Overview with Load Capacities. Determination of the dynamic of the load capacities and moments is based on 100,000 m of stroke travel. Often only 50,000 m are actually stipulated. Comparison: Value C, M_t and M_L per table multiplied by 1.26.

Product Overview Super Runner Blocks Steel Version

Excellent properties

- Automatically compensates for errors in alignment of up to 10' arc about two axes
- Extra-compact design
- Identical load capacities in all four main directions
- Wider permissible tolerances for parallelism and height of mounting surfaces
- Accuracy classes H and N
- Preload class: clearance and 2% preload
- Smooth running due to optimized ball recirculation and entry-zone geometry

Make up your own compact linear motion guideways from interchangeable standard stock elements...

Rexroth manufactures its guide rails and runner blocks with such high precision, especially in the ball track zone, that each individual component element can be replaced by another at any time. This makes infinite combinations possible within each accuracy class.

Self-alignment

The Rexroth Super Runner Block with self-aligning feature automatically compensates for errors in alignment to 10' of arc. There is no load capacity reduction through compression across the edges.

The center of the mating surfaces supporting the steel load bearing plates serve as a rocking fulcrum.

Therefore slight errors in alignment between runner block and guide rail do not cause problems.

Also, inaccuracies in machining, mounting errors or guide rail bending will automatically be corrected.

The self-aligning feature assures smooth entry and exit of the balls into and out of the load-carrying area and uniform load distribution over the entire row of balls.

The result is extra-smooth running and considerably longer service life.

With two runner blocks on one guide rail, it is also possible to produce tilt-free linear rolling motion guides with a high load capacity, particularly for handling applications.

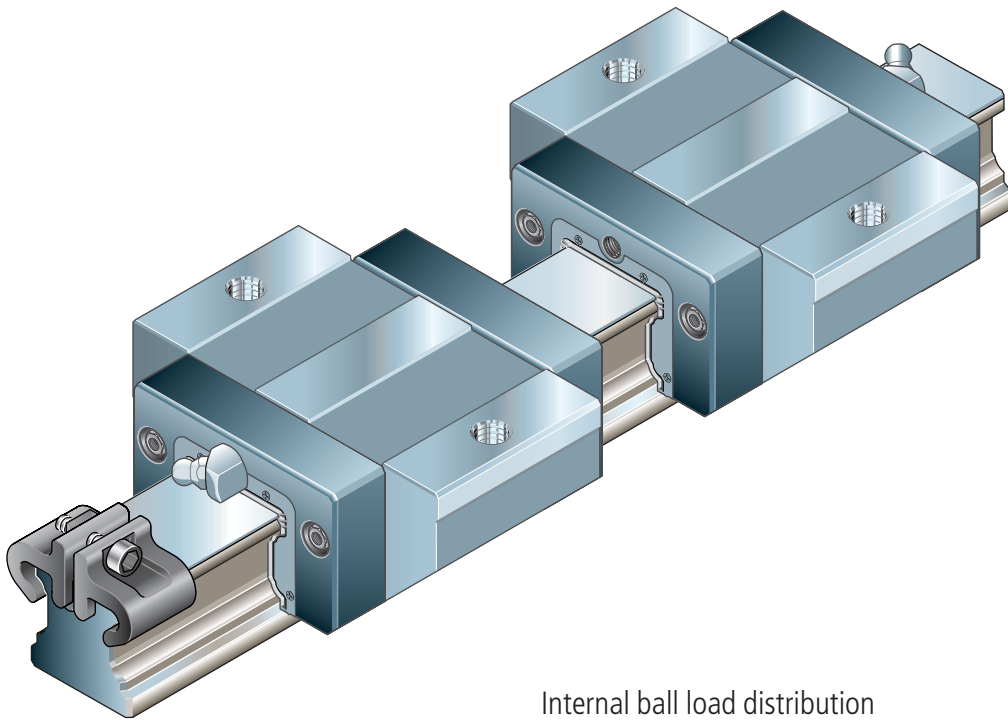

Internal ball load distribution
in the case of angle errors α

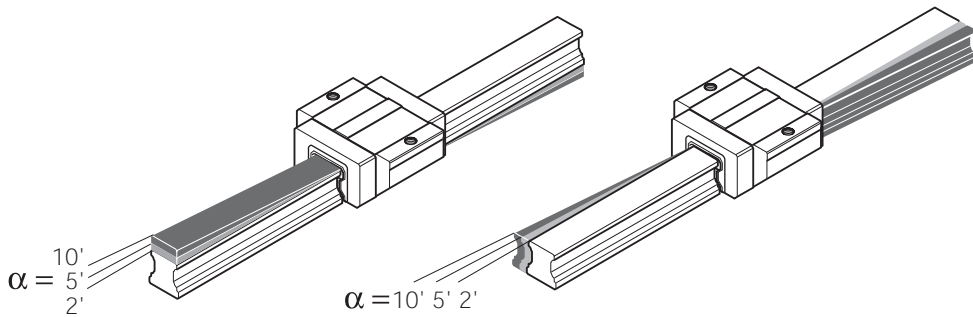

Internal ball load distribution
Rexroth rail system
with self-aligning feature **S**

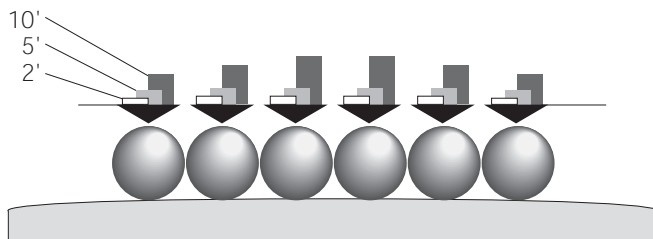

Internal load distribution
Rail systems
without self-alignment feature

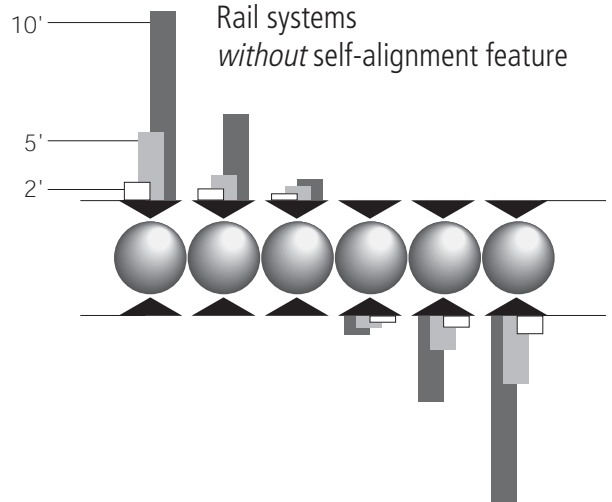

Super Runner Blocks Steel Version

Super Runner Block FKS with self-aligning feature R1661

Flange Short

- Runner block without ball chain: for part numbers, see table
- Runner block with low friction seal without ball chain: Part numbers R1661 xxx 11

Dynamic characteristics

Speed	$v_{\max} = 3 \text{ m/s}$
Acceleration	$a_{\max} = 250 \text{ m/s}^2$

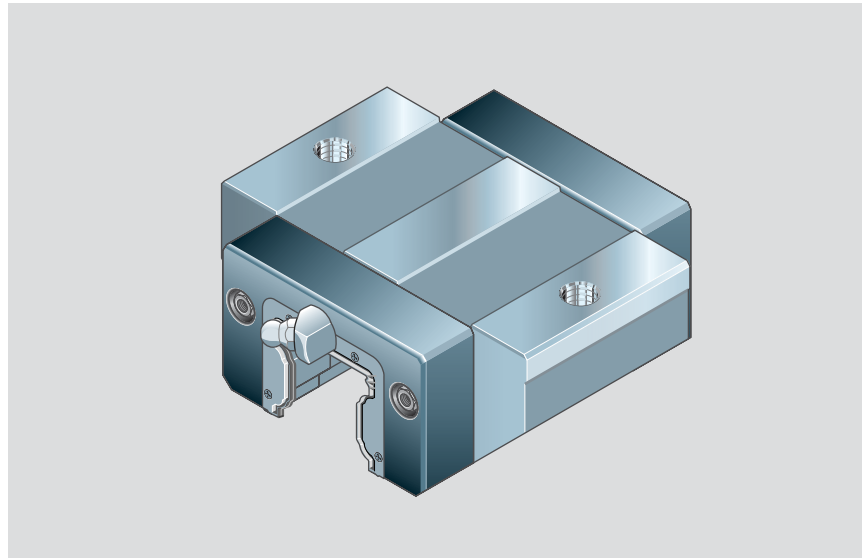

Precision Runner Blocks

- Not Pre-lubricated

Size	Accuracy Class	Part numbers for runner blocks for preload class	
		C0	C1
15	N	R1661 194 10	R1661 114 10
	H	R1661 193 10	R1661 113 10
20	N	R1661 894 10	R1661 814 10
	H	R1661 893 10	R1661 813 10
25	N	R1661 294 10	R1661 214 10
	H	R1661 293 10	R1661 213 10
30	N	R1661 794 10	R1661 714 10
	H	R1661 793 10	R1661 713 10
35	N	R1661 394 10	R1661 314 10
	H	R1661 393 10	R1661 313 10

Corrosion resistant Custom version

Resist CR – Chromium-plated matt silver runner block housing

- Not Pre-lubricated

Size	Accuracy Class	Part numbers for runner blocks for preload class	
		C0	C1
15	H	R1661 193 60	
20	H	R1661 893 60	
25	H	R1661 293 60	
30	H	R1661 793 60	R1661 713 60
35	H	R1661 393 60	R1661 313 60

Preload Class

C0 = without Preload

C1 = Preload 2% C

For further technical information, please see chapter on "General Technical Data and Calculations".

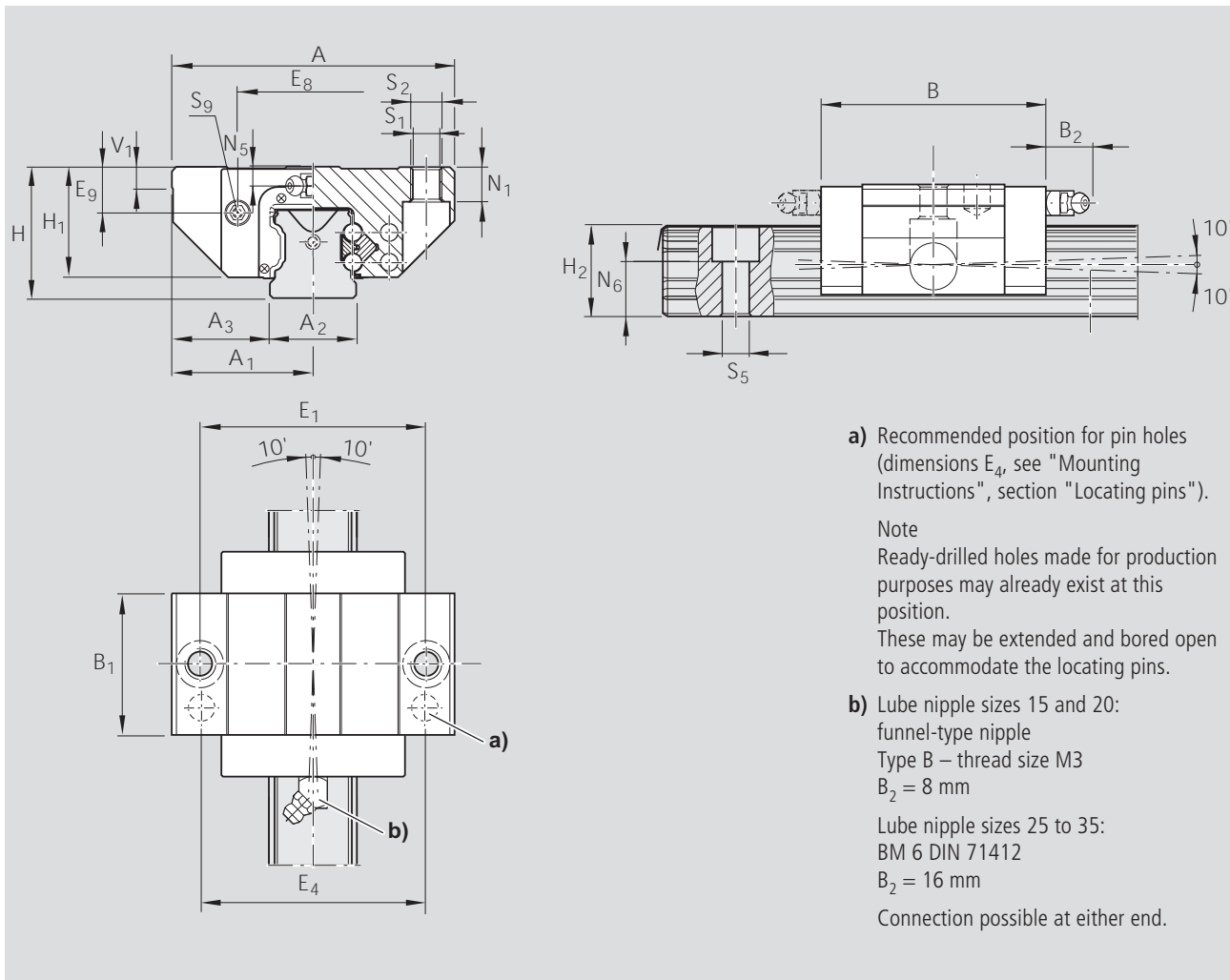

Size	Dimensions (mm)														
	A	A ₁	A ₂	A ₃	B	B ₁	H	H ₁	H ₂ ¹⁾	H ₂ ²⁾	V ₁	E ₁	E ₈	E ₉	N ₁
15	47	23.5	15	16.0	40.5	25.7	24	19.8	16.3	16.20	5.0	38	24.55	6.7	5.0
20	63	31.5	20	21.5	52.5	31.9	30	25.4	20.7	20.55	6.0	53	32.40	7.3	7.5
25	70	35.0	23	23.5	61.5	38.6	36	29.5	24.4	24.25	7.5	57	38.30	11.5	9.0
30	90	45.0	28	31.0	71.5	45.0	42	35.0	28.5	28.35	7.0	72	48.40	14.6	11.0
35	100	50.0	34	33.0	79.0	51.4	48	40.0	32.15	31.85	8.0	82	58.00	17.5	12.0

1) Dimension H₂ with rail seal cover strip

2) Dimension H₂ without rail seal cover strip

Size	Dimensions (mm)							Mass (kg)	Load capacities (N) C dyn.	Permissible load (N) F _{max}	Moments (Nm)	
	N ₅	N ₆ ^{±0.5}	S ₁	S ₂	S ₅	S ₉	M _t dyn.				M _t max.	
15	4.0	10.3	4.4	M5	4.4	M2.5-3.5 deep	0.19	3 900	1 500	39	15	
20	4.7	13.2	5.4	M6	6.0	M3-5 deep	0.30	10 100	3 900	130	50	
25	5.5	15.2	6.8	M8	7.0	M3-5 deep	0.50	11 400	4 400	170	65	
30	6.0	17.0	8.6	M10	9.0	M3 5 deep	0.90	15 800	6 100	270	105	
35	7.0	20.5	8.6	M10	9.0	M3-5 deep	1.35	21 100	8 100	450	175	

Determination of the dynamic of the load capacities and moments is based on 100,000 m of stroke travel, however, only 50,000 m are often actually stipulated. Comparison: Value C, M_t und M_t per table multiplied by 1.26.

Super Runner Blocks Steel Version

Super Runner Block SKS with self-aligning feature R1662

Slimline Short

- Runner block without ball chain: for part numbers, see table
- Runner block with low friction seal without ball chain: Part numbers R1662 xxx 11

Dynamic characteristics

Speed $v_{max} = 3 \text{ m/s}$
 Acceleration $a_{max} = 250 \text{ m/s}^2$

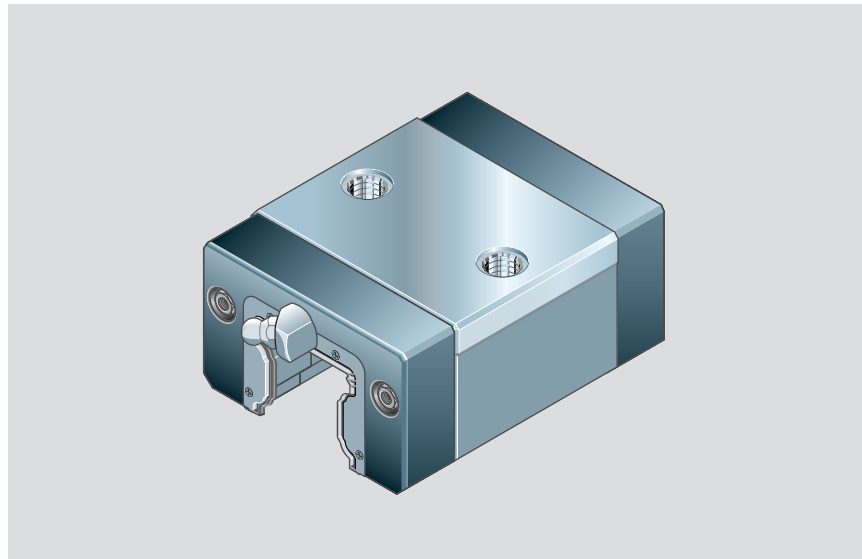

Precision Runner Blocks

– Not Pre-lubricated

Size	Accuracy Class	Part numbers for runner blocks for preload class	
		C0	C1
15	N	R1662 194 10	R1662 114 10
	H	R1662 193 10	R1662 113 10
20	N	R1662 894 10	R1662 814 10
	H	R1662 893 10	R1662 813 10
25	N	R1662 294 10	R1662 214 10
	H	R1662 293 10	R1662 213 10
30	N	R1662 794 10	R1662 714 10
	H	R1662 793 10	R1662 713 10
35	N	R1662 394 10	R1662 314 10
	H	R1662 393 10	R1662 313 10

Corrosion resistant

Custom version

Resist CR – Chromium-plated matt silver runner block housing

– Not Pre-lubricated

Size	Accuracy Class	Part numbers for runner blocks for preload class	
		C0	C1
15	H	R1662 193 60	
20	H	R1662 893 60	
25	H	R1662 293 60	
30	H	R1662 793 60	R1662 713 60
35	H	R1662 393 60	R1662 313 60

Preload Class

C0 = without Preload

C1 = Preload 2% C

For further technical information, please see chapter on "General Technical Data and Calculations".

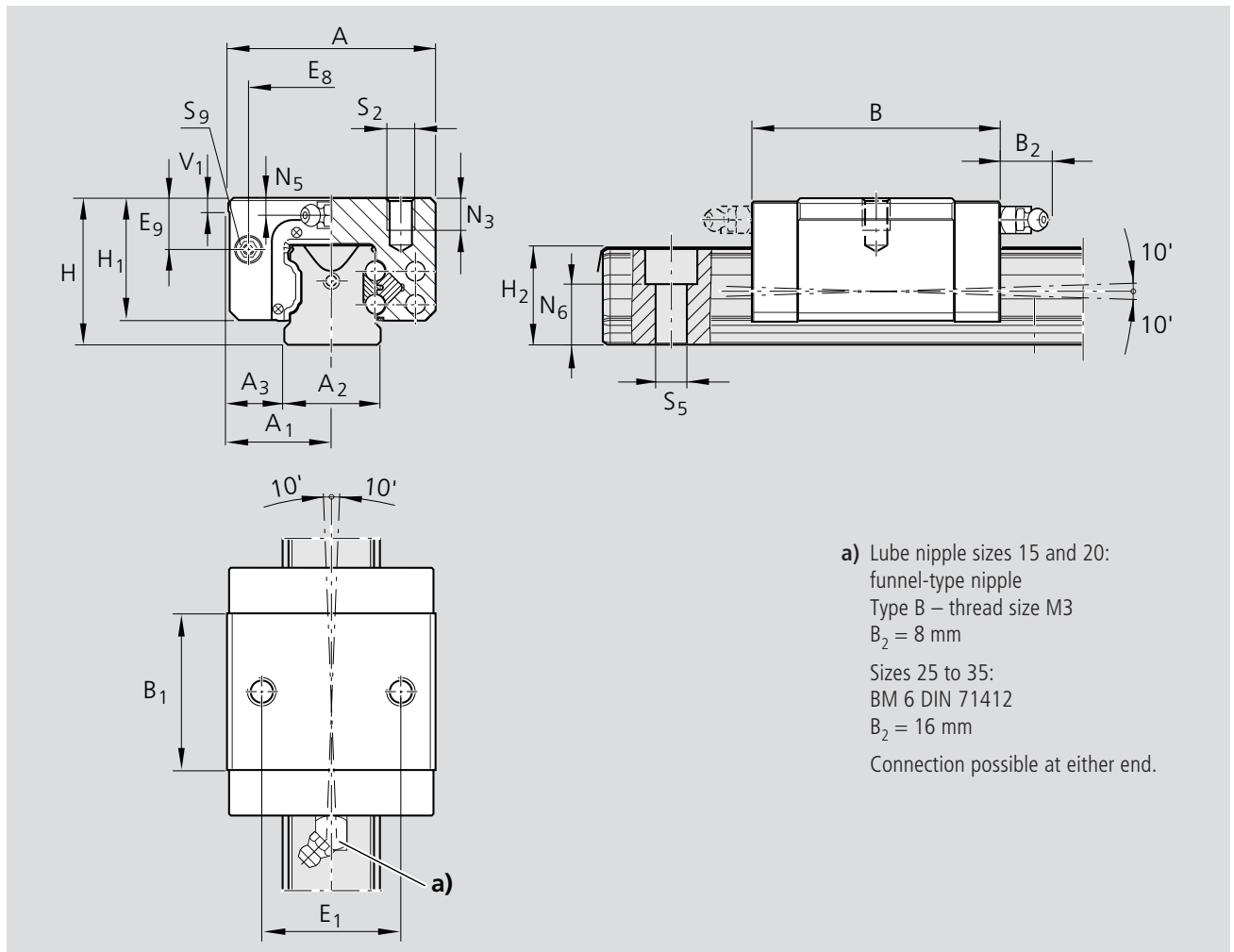

Size	Dimensions (mm)														
	A	A ₁	A ₂	A ₃	B	B ₁	H	H ₁	H ₂ ¹⁾	H ₂ ²⁾	V ₁	E ₁	E ₈	E ₉	N ₃
15	34	17	15	9.5	40.5	25.7	24	19.8	16.30	16.20	5.0	26	24.55	6.7	6.0
20	44	22	20	12.0	52.5	31.9	30	25.4	20.75	20.55	6.0	32	32.40	7.3	7.5
25	48	24	23	12.5	61.5	38.6	36	29.5	24.45	24.25	7.5	35	38.30	11.5	9.0
30	60	30	28	16.0	71.5	45.0	42	35.0	28.55	28.35	7.0	40	48.40	14.6	12.0
35	70	35	34	18.0	79.0	51.4	48	40.0	32.15	31.85	8.0	50	58.00	17.5	13.0

¹⁾ Dimension H₂ with rail seal cover strip

²⁾ Dimension H₂ without rail seal cover strip

Size	Dimensions (mm)						Mass (kg)	Load capacities (N)	Permissible load (N)	Moments (Nm)	
	N ₅	N ₆ ±0.5	S ₂	S ₅	S ₉	C dyn.		F _{max}	M _t dyn.	M _t max.	
15	4.0	10.3	M4	4.4	M2.5-3.5 deep	0.12	3 900	1 500	39	15	
20	4.7	13.2	M5	6.0	M3-5 deep	0.25	10 100	3 900	130	50	
25	5.5	15.2	M6	7.0	M3-5 deep	0.40	11 400	4 400	170	65	
30	6.0	17.0	M8	9.0	M3-5 deep	0.65	15 800	6 100	270	105	
35	7.0	20.5	M8	9.0	M3-5 deep	0.95	21 100	8 100	450	175	

Determination of the dynamic of the load capacities and moments is based on 100,000 m of stroke travel, however, only 50,000 m are often actually stipulated. Comparison: Value C, M_t und M_L per table multiplied by 1.26.

Product Overview Runner Blocks, Aluminium Version

Excellent Properties

Rexroth Ball Rail Systems with Aluminium runner blocks were specifically developed for use in industrial robots and general purpose machines calling for compact, rolling-element linear motion guideways and are available in different accuracy classes, each with high load capacity and high rigidity.

These compact and weight-saving assemblies are available in 4 common sizes and offer the same high dynamic load capacities in all four main load directions.

- High torque load capacity
- Optimized entry-zone geometry and the high number of balls per track greatly reduce variation in elastic deflection
- Very low weight: 60% lighter than the equivalent steel version

Further Highlights

- Wider permissible tolerances for parallelism and height of mounting surfaces
- Accuracy classes H and N can be combined with any of the rails in each accuracy class
- Lube port at either end for added ease of maintenance
- End face mounting holes for attachment of bellows or scraper plates
- Guide rails in accuracy class H also available with surface protection
- Smooth, light running due to optimized ball recirculation and ideal ball/track geometry
- Improved rigidity under lift-off and side loading conditions when additional mounting screws are used in holes provided at the center of the runner block
- Attachments can be mounted to runner block from above or below
- Pre-drilled locating pin holes in runner blocks

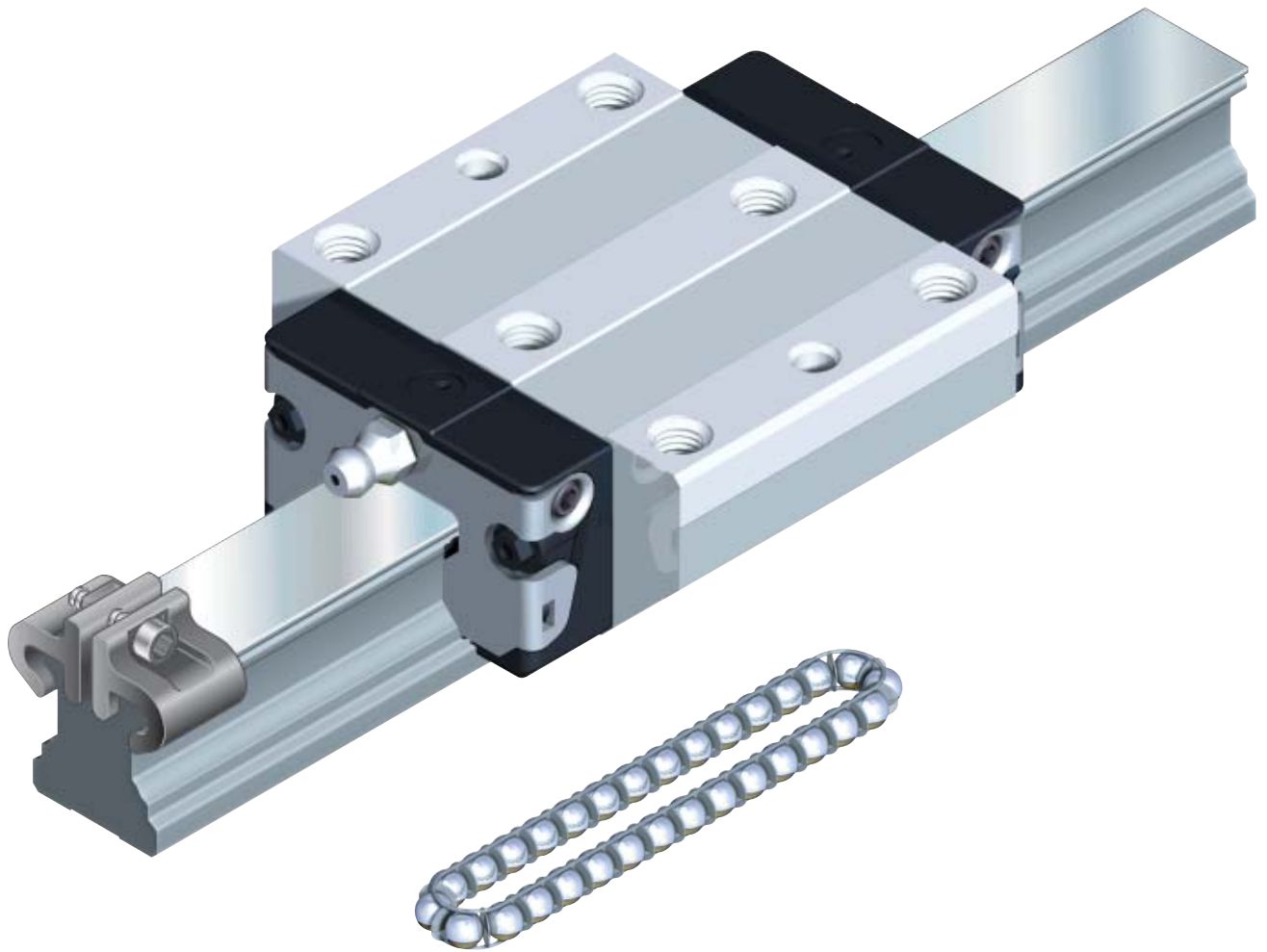

Ball Chain

– Optimized noise level and running characteristics

Make up your own compact linear motion guideways from interchangeable standard stock elements...

Rexroth manufactures its guide rails and runner blocks with such high precision, especially in the ball track zone, that each individual component element can be replaced by another at any time. This makes infinite combinations possible within each accuracy class. Each element can be individually ordered and separately stocked.

Both sides of the guide rail can be used as reference edges. The runner block is simply pushed onto the rail.

Runner Blocks, Aluminium Version

Runner Block FNS

R1631

Flange Standard

- Runner block without ball chain:
for part numbers, see table
- Runner block with low friction seal without ball chain:
Part numbers R1631 xxx 21
- Runner block with ball chain:
Part numbers R1631 xxx 22
- Runner block with low friction seal with ball chain:
Part numbers R1631 xxx 23

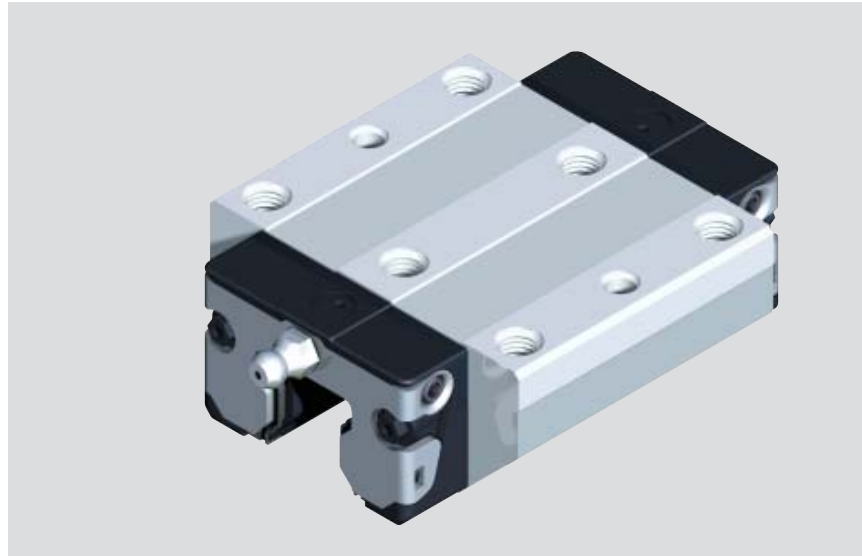

Dynamic characteristics

Speed $v_{max} = 5 \text{ m/s}$
 Acceleration $a_{max} = 500 \text{ m/s}^2$

Precision Runner Blocks

- Pre-lubricated

Size	Accuracy Class	Part numbers for runner blocks for preload class	
		C0	C1
15	N	R1631 194 20	R1631 114 20
	H	R1631 193 20	R1631 113 20
20*	N	R1631 894 20	R1631 114 20
	H	R1631 893 20	R1631 113 20
25	N	R1631 294 20	R1631 214 20
	H	R1631 293 20	R1631 213 20
30	N	R1631 794 20	R1631 714 20
	H	R1631 793 20	R1631 713 20
35	N	R1631 394 20	R1631 314 20
	H	R1631 393 20	R1631 313 20

* In Preparation

Size	Load Capacities	Permissible Load (N)	Moments (Nm)			
	(N) C dyn.		Fmax	Mt dyn.	Mt max.	ML dyn.
15	7 800	3 000	74	29	40	16
20*	18 800	7 200	240	92	130	50
25	22 800	8 800	320	125	180	70
30	31 700	12 200	540	210	290	110
35	41 900	16 200	890	345	440	170

Preload Class

C0 = without Preload
 C1 = Preload 2% C

For further technical information, please see chapter on "General Technical Data and Calculations".

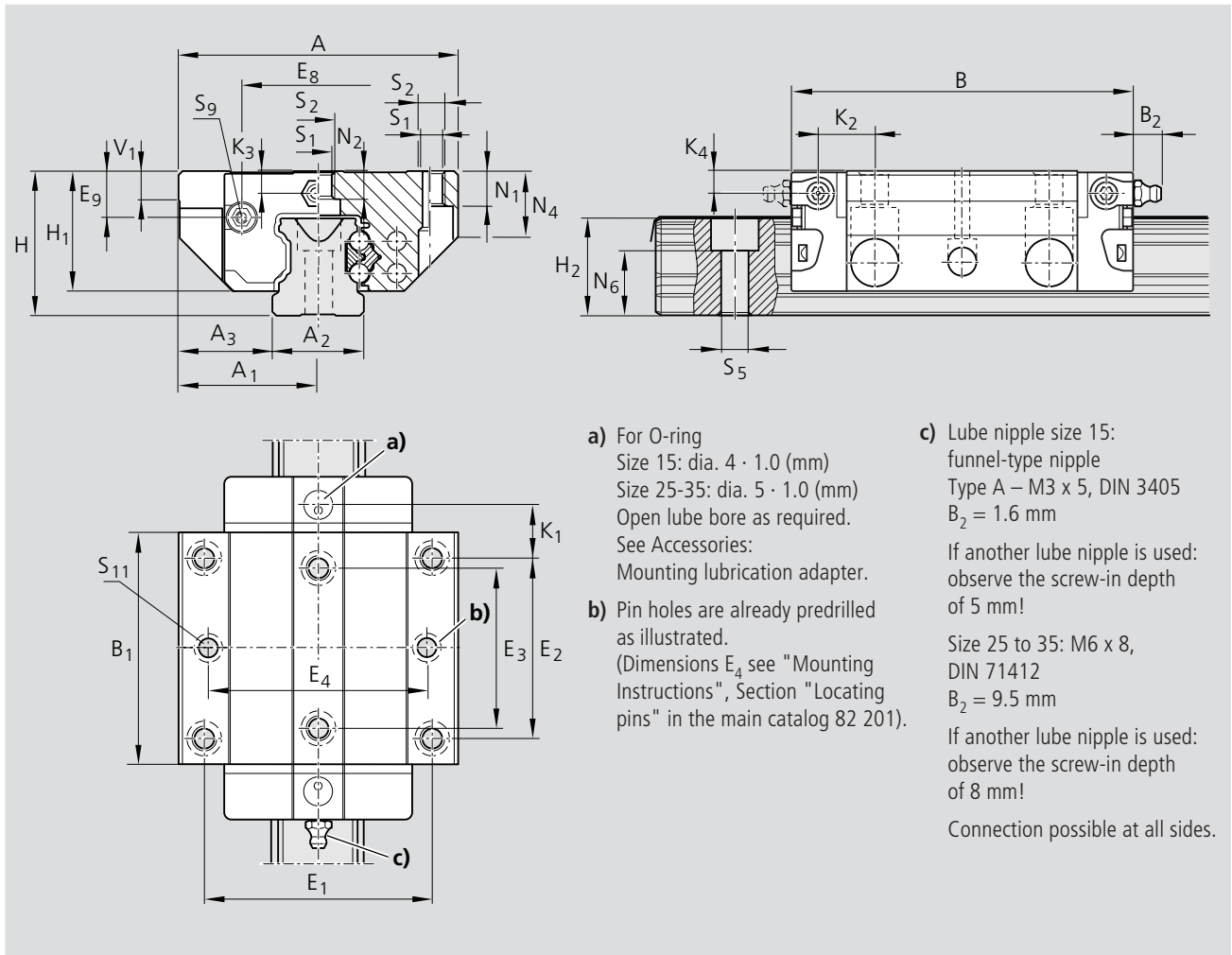

Dimensions (mm)																				
Size	A	A ₁	A ₂	A ₃	B	B ₁	H	H ₁	H ₂ ¹⁾	H ₂ ²⁾	V ₁	E ₁	E ₂	E ₃	E ₈	E ₉	K ₁	K ₂	K ₃	K ₄
15	47	23.5	15	16.0	58.2	39.2	24	19.90	16.30	16.20	5.0	38	30	26	24.55	6.70	8.00	9.6	3.20	3.20
25	70	35.0	23	23.5	86.2	57.8	36	29.90	24.45	24.25	7.5	57	45	40	38.30	11.50	12.45	13.6	5.50	5.50
30	90	45.0	28	31.0	97.7	67.4	42	35.35	28.55	28.35	7.0	72	52	44	48.40	14.60	14.00	15.7	6.05	6.05
35	100	50.0	34	33.0	110.5	77.0	48	40.40	32.15	31.85	8.0	82	62	52	58.00	17.35	14.50	16.0	6.90	6.90

¹⁾ Dimension H₂ with rail seal cover strip

²⁾ Dimension H₂ without rail seal cover strip

Dimension (mm)										Mass
Size	N ₁	N ₂	N ₄	N ₆ ^{±0.5}	S ₁	S ₂	S ₁₁	S ₅	S ₉	(kg)
15	5.2	4.4	10.3	10.65	4.3	M5	3.7	4.4	M2.5-3.5 deep	0.10
25	9.3	7.0	17.8	15.55	6.7	M8	5.7	7.0	M3-5 deep	0.30
30	11.0	7.9	20.5	17.35	8.5	M10	7.7	9.0	M3-5 deep	0.55
35	12.0	10.2	24.0	20.85	8.5	M10	7.7	9.0	M3-5 deep	0.75

Determination of the dynamic of the load capacities and moments is based on 100,000 m of stroke travel, however, only 50,000 m are often actually stipulated. Comparison: Value C, M_t und M_l per table multiplied by 1.26.

Runner Blocks, Aluminium Version

Runner Block SNS R1632

Slimline Standard

- Runner block without ball chain:
for part numbers, see table
- Runner block with low friction seal
without ball chain:
Part numbers R1632 xxx 21
- Runner block with ball chain:
Part numbers R1632 xxx 22
- Runner block with low friction seal with
ball chain:
Part numbers R1632 xxx 23

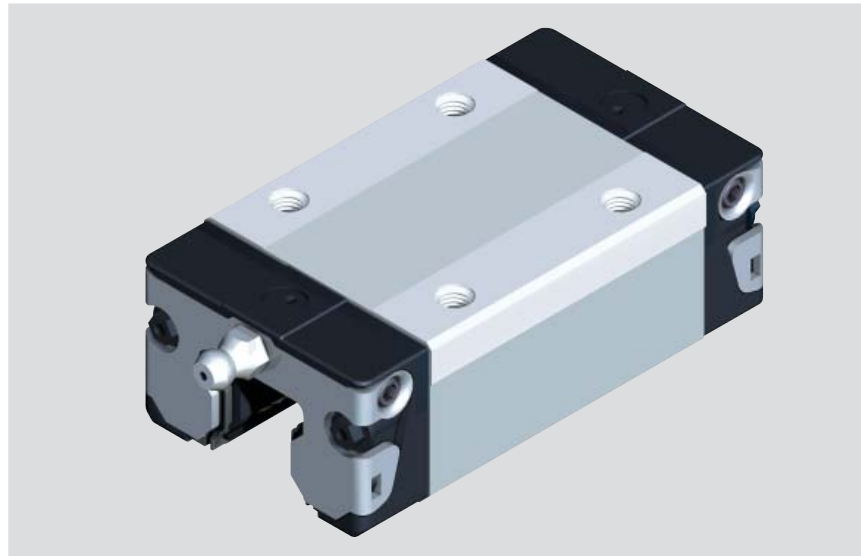

Dynamic characteristics

Speed $v_{\max} = 5 \text{ m/s}$

Acceleration $a_{\max} = 500 \text{ m/s}^2$

Precision Runner Blocks

- Pre-lubricated

Size	Accuracy Class	Part numbers for runner blocks for preload class	
		C0	C1
15	N	R1632 194 20	R1632 114 20
	H	R1632 193 20	R1632 113 20
20*	N	R1632 894 20	R1632 114 20
	H	R1632 893 20	R1632 113 20
25	N	R1632 294 20	R1632 214 20
	H	R1632 293 20	R1632 213 20
30	N	R1632 794 20	R1632 714 20
	H	R1632 793 20	R1632 713 20
35	N	R1632 394 20	R1632 314 20
	H	R1632 393 20	R1632 313 20

* In Preparation

Preload Class

C0 = without Preload

C1 = Preload 2% C

For further technical information, please see chapter on "General Technical Data and Calculations".

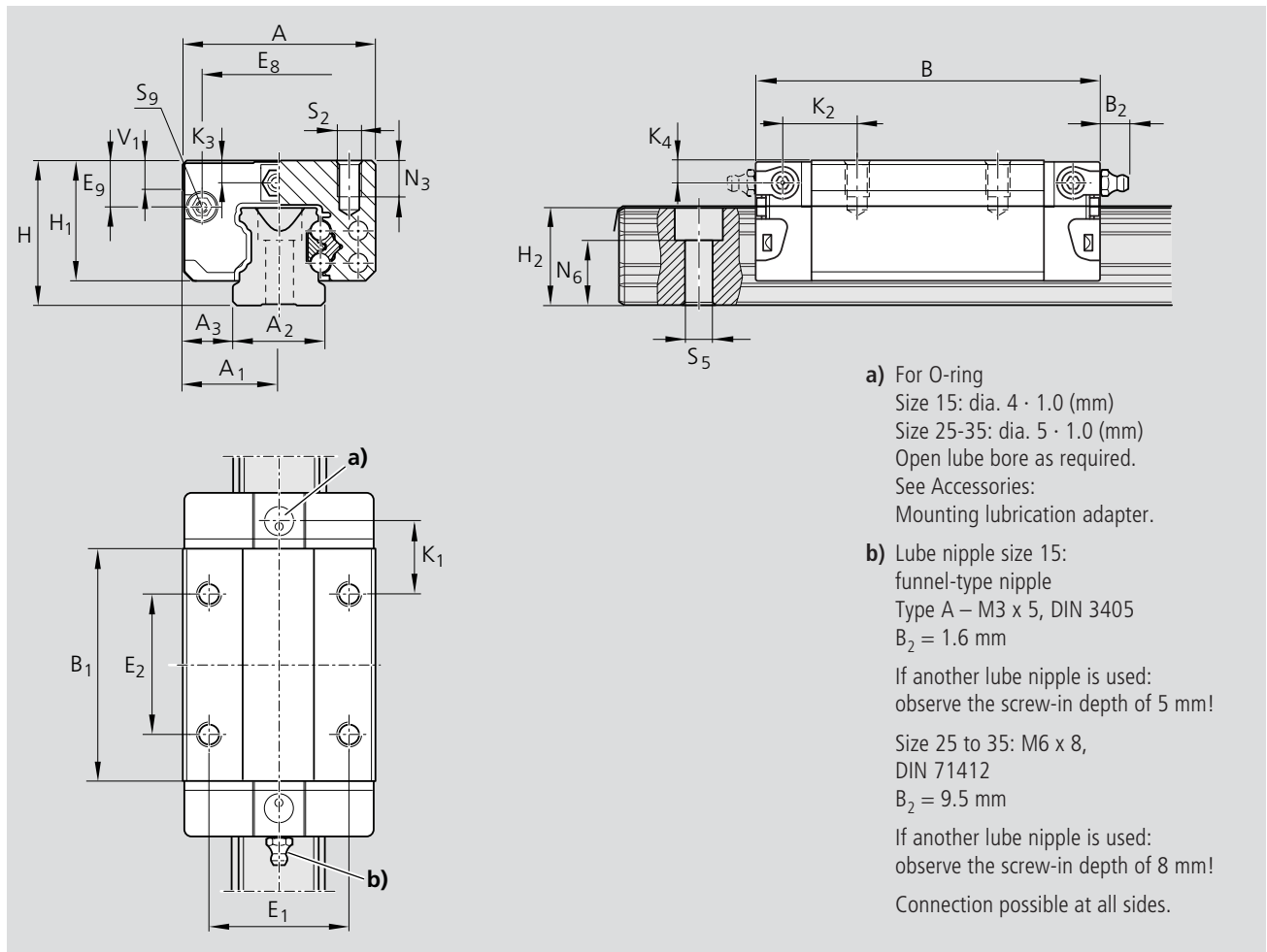

Dimensions (mm)																			
Size	A	A ₁	A ₂	A ₃	B	B ₁	H	H ₁	H ₂ ¹⁾	H ₂ ²⁾	V ₁	E ₁	E ₂	E ₈	E ₉	K ₁	K ₂	K ₃	K ₄
15	34	17	15	9.5	58.2	39.2	24	19.90	16.30	16.20	5.0	26	26	24.55	6.70	10.00	11.60	3.20	3.20
25	48	24	23	12.5	86.2	57.8	36	29.90	24.45	24.25	7.5	35	35	38.30	11.50	17.45	18.60	5.50	5.50
30	60	30	28	16.0	97.7	67.4	42	35.35	28.55	28.35	7.0	40	40	48.40	14.60	20.00	21.70	6.05	6.05
35	70	35	34	18.0	110.5	77.0	48	40.40	32.15	31.85	8.0	50	50	58.00	17.35	20.50	22.00	6.90	6.90

1) Dimension H₂ with rail seal cover strip

2) Dimension H₂ without rail seal cover strip

Dimensions (mm)							Load capacities (N)	Permissible load (N)	Moments (Nm)			
Size	N ₃	N ₆ ^{±0.5}	S ₂	S ₅	S ₉	Mass (kg)	C dyn.	F _{max}	M _t dyn.	M _t max.	M _L dyn.	M _L max.
15	6.0	10.65	M4	4.4	M2.5-3.5 deep	0.10	7 800	3 000	74	29	40	16
25	9.0	15.55	M6	7.0	M3-5 deep	0.25	22 800	8 800	320	125	180	70
30	12.0	17.35	M8	9.0	M3-5 deep	0.45	31 700	12 200	540	210	290	110
35	13.0	20.65	M8	9.0	M3-5 deep	0.65	41 900	16 200	890	345	440	170

Determination of the dynamic of the load capacities and moments is based on 100,000 m of stroke travel, however, only 50,000 m are often actually stipulated. Comparison: Value C, M_t und M_L per table multiplied by 1.26.

Product Overview High-speed Runner Blocks

Excellent properties of the new runner blocks:

- Excellent dynamic characteristics $v = 10 \text{ m/s}$; $a_{\text{max}} = 500 \text{ m/s}^2$
- High load capacities in all 4 main load directions
- Long-term lubrication, up to several years
- Minimum quantity lubrication system with integrated reservoir for oil lubrication
- Lube ports with metal threads on all sides
- Limitless interchangeability due to standardized guide rails, with or without rail seal cover strip, for all runner block versions
- Optimum system rigidity through preloaded O-arrangement
- Electrically insulating due to the use of ceramic balls
- Existing range of accessories fully utilizable
- Unique solution only available from Rexroth

Further highlights:

- High speed due to low mass of the ceramic balls
- Runner block can be bolted from above or below
- Improved rigidity under lift-off and side loading conditions when additional mounting screws are used in holes provided at the center of the runner block
- Front face securing threads for all attachments
- High rigidity in all load directions – can therefore be used as an individual block
- Integral, all-round sealing
- High torque load capacity
- Optimized entry-zone geometry and the high number of balls per track greatly reduce variation in elastic deflection
- Smooth, light running due to optimized ball recirculation and ideal ball/track geometry
- Various preload classes
- Available in 5 common sizes

**For speeds
up to 10 m/s**

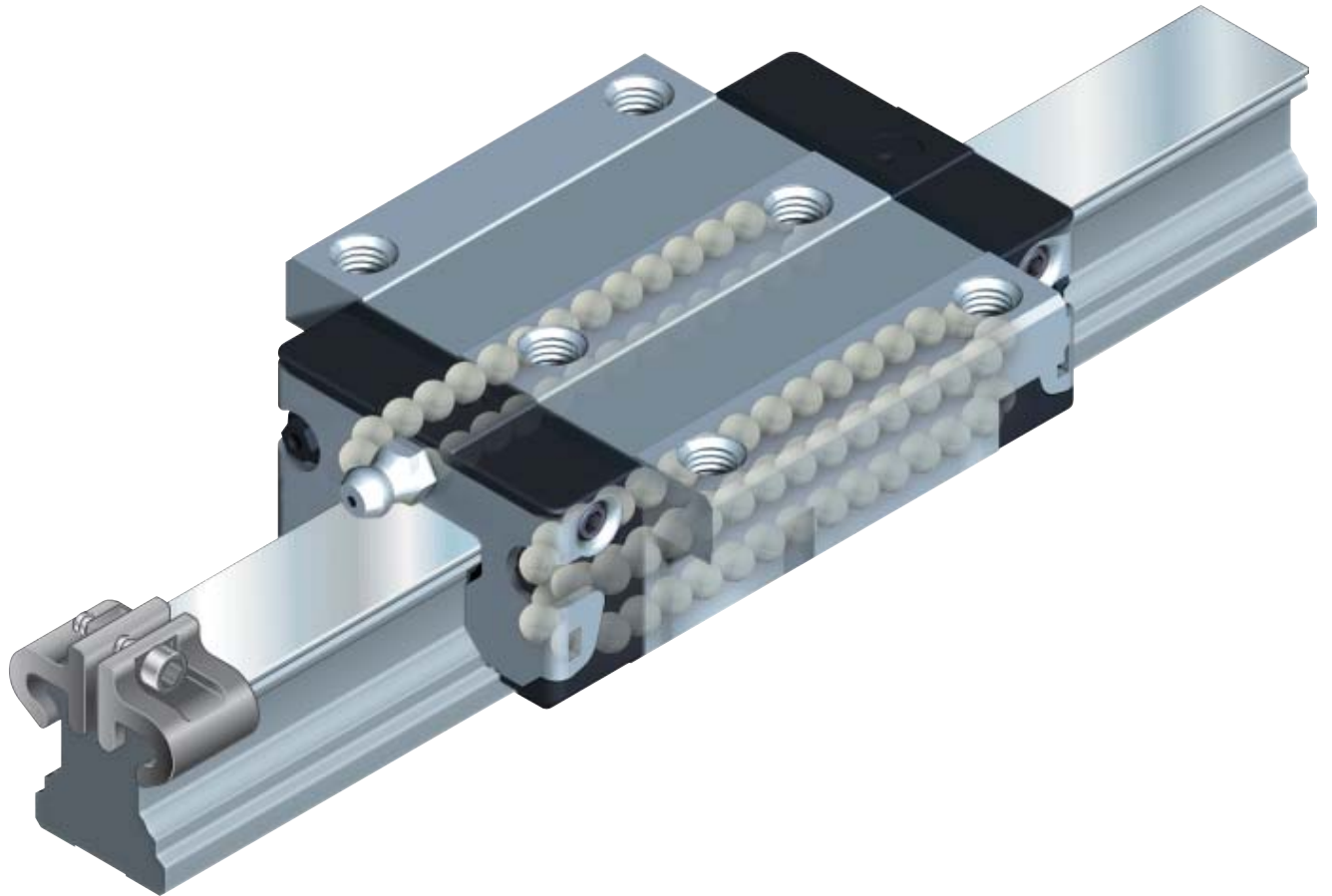

High-speed Runner Block, Steel Version

Runner Block FNS R2001

Flange Standard, high-speed version

- Runner block without ball chain:
for part numbers, see table

Dynamic characteristics

Speed	$v_{\max} = 10 \text{ m/s}$
Acceleration	$a_{\max} = 500 \text{ m/s}^2$

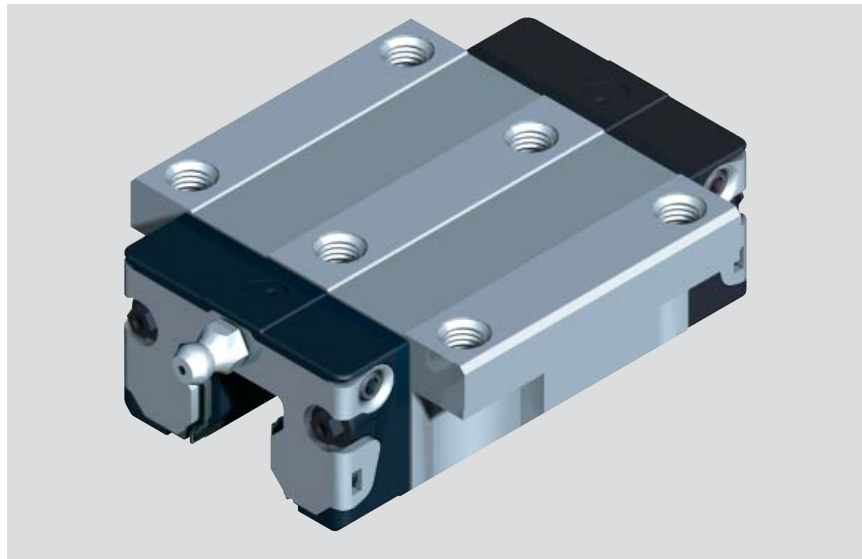

Precision Runner Blocks

- Pre-lubricated

Size	Accuracy Class	Part numbers for runner blocks for preload class C2
15	H	R2001 123 90
	P	R2001 122 90
20	H	R2001 823 90
	P	R2001 822 90
25	H	R2001 223 90
	P	R2001 222 90
30	H	R2001 723 90
	P	R2001 722 90
35	H	R2001 323 90
	P	R2001 322 90

Preload Class

C2 = Preload 8% C

For further technical information, please see chapter on "General Technical Data and Calculations".

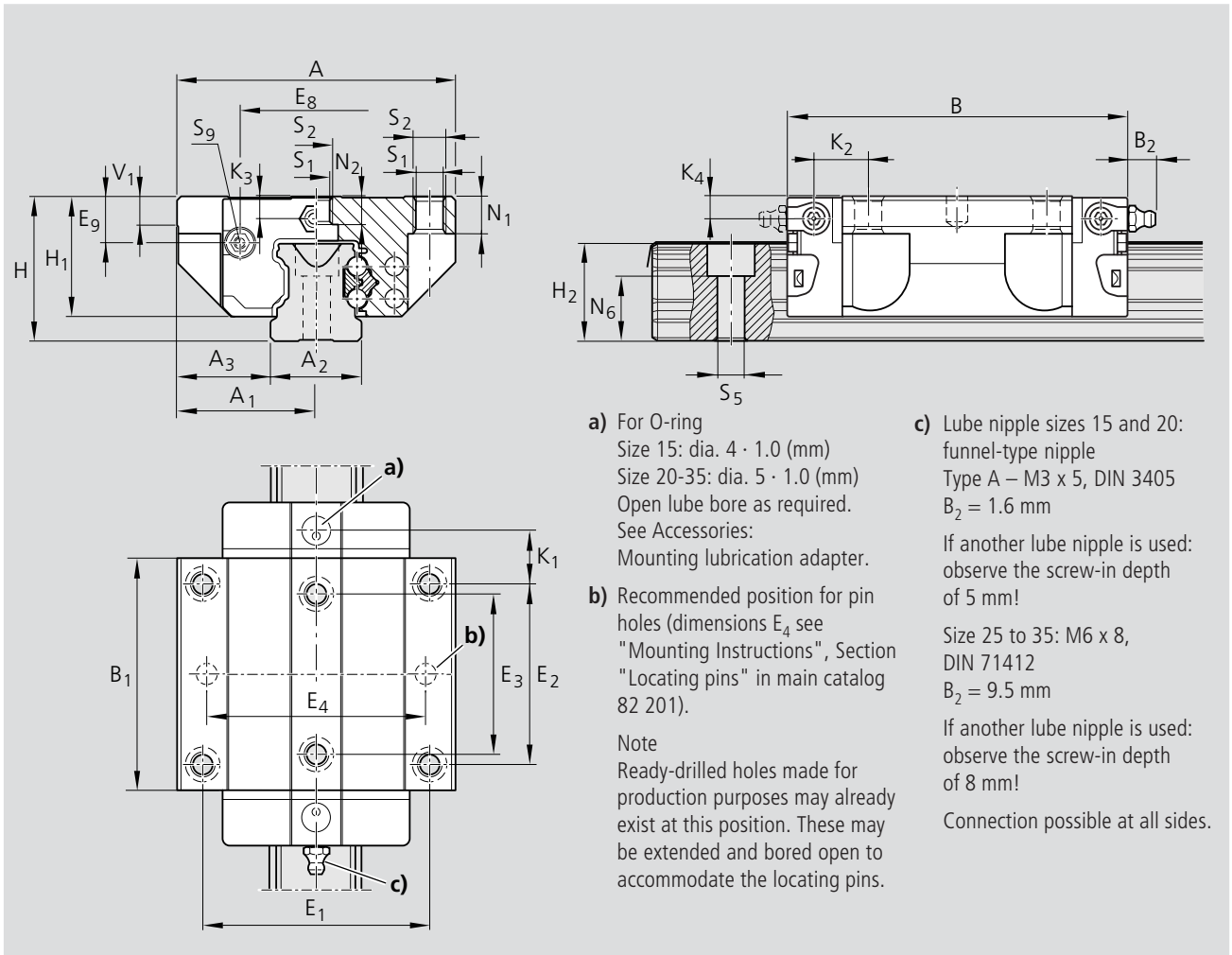

- a) For O-ring
 Size 15: dia. 4 · 1.0 (mm)
 Size 20-35: dia. 5 · 1.0 (mm)
 Open lube bore as required.
 See Accessories:
 Mounting lubrication adapter.
- b) Recommended position for pin holes (dimensions E₄ see "Mounting Instructions", Section "Locating pins" in main catalog 82 201).

 Note
 Ready-drilled holes made for production purposes may already exist at this position. These may be extended and bored open to accommodate the locating pins.
- c) Lube nipple sizes 15 and 20:
 funnel-type nipple
 Type A – M3 x 5, DIN 3405
 B₂ = 1.6 mm

 If another lube nipple is used:
 observe the screw-in depth of 5 mm!

 Size 25 to 35: M6 x 8, DIN 71412
 B₂ = 9.5 mm

 If another lube nipple is used:
 observe the screw-in depth of 8 mm!

 Connection possible at all sides.

Size	Dimensions (mm)																			
	A	A ₁	A ₂	A ₃	B	B ₁	H	H ₁	H ₂ ¹⁾	H ₂ ²⁾	V ₁	E ₁	E ₂	E ₃	E ₈	E ₉	K ₁	K ₂	K ₃	K ₄
15	47	23.5	15	16.0	58.2	39.2	24	19.90	16.30	16.20	5.0	38	30	26	24.55	6.70	8.00	9.6	3.20	3.20
20	63	31.5	20	21.5	75.0	49.6	30	25.35	20.75	20.55	6.0	53	40	35	32.50	7.30	11.80	11.8	3.35	3.35
25	70	35.0	23	23.5	86.2	57.8	36	29.90	24.45	24.25	7.5	57	45	40	38.30	11.50	12.45	13.6	5.50	5.50
30	90	45.0	28	31.0	97.7	67.4	42	35.35	28.55	28.35	7.0	72	52	44	48.40	14.60	14.00	15.7	6.05	6.05
35	100	50.0	34	33.0	110.5	77.0	48	40.40	32.15	31.85	8.0	82	62	52	58.00	17.35	14.50	16.0	6.90	6.90

1) Dimension H₂ with rail seal cover strip

2) Dimension H₂ without rail seal cover strip

Size	Dimensions (mm)								Mass (kg)	Load capacities (N)		Moments (Nm)			
	N ₁	N ₂	N ₆ ^{±0.5}	S ₁	S ₂	S ₅	S ₉	C dyn.		C ₀ stat.	M _t dyn.	M _{t0} stat.	M _L dyn.	M _{L0} stat.	
15	5.2	4.4	10.65	4.3	M5	4.4	M2.5-3.5 deep	0.20	5 300	9 100	50	88	27	48	
20	7.7	5.2	13.35	5.3	M6	6.0	M3-5 deep	0.45	12 700	16 500	160	210	88	110	
25	9.3	7.0	15.55	6.7	M8	7.0	M3-5 deep	0.60	15 500	20 600	210	290	120	160	
30	11.0	7.9	17.35	8.5	M10	9.0	M3-5 deep	1.05	21 500	28 000	360	490	190	250	
35	12.0	10.2	20.85	8.5	M10	9.0	M3-5 deep	1.50	28 500	36 700	600	780	300	380	

Determination of the dynamic of the load capacities and moments is based on 100,000 m of stroke travel, however, only 50,000 m are often actually stipulated. Comparison: Value C, M_t and M_L per table multiplied by 1.26.

High-speed Runner Block, Steel Version

Runner Block SNS R2011

Slimline Standard, high-speed version

- Runner block without ball chain:
for part numbers, see table

Dynamic characteristics

Speed	$v_{\max} = 10 \text{ m/s}$
Acceleration	$a_{\max} = 500 \text{ m/s}^2$

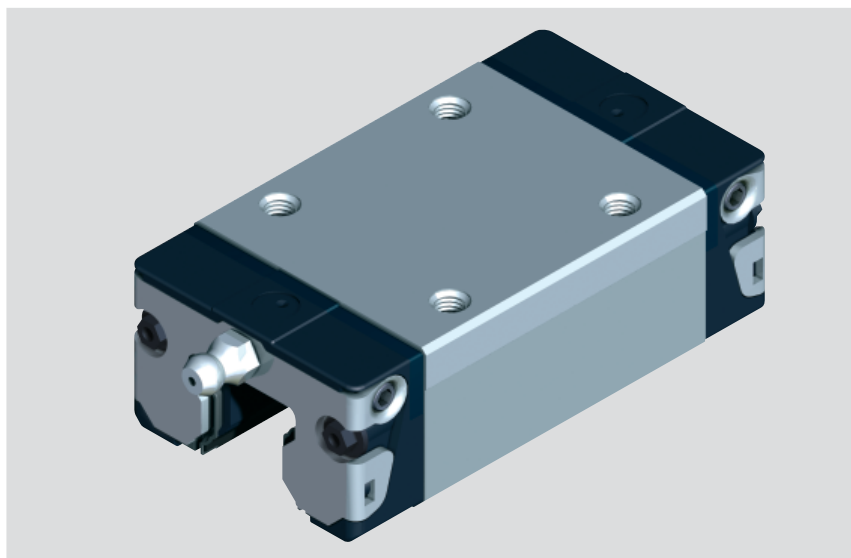

Precision Runner Blocks

- Pre-lubricated

Size	Accuracy Class	Part numbers for runner blocks for preload class C2
15	H	R2001 123 90
	P	R2001 122 90
20	H	R2001 823 90
	P	R2001 822 90
25	H	R2001 223 90
	P	R2001 222 90
30	H	R2001 723 90
	P	R2001 722 90
35	H	R2001 323 90
	P	R2001 322 90

Preload Class

C2 = Preload 8% C

For further technical information, please see chapter on "General Technical Data and Calculations".

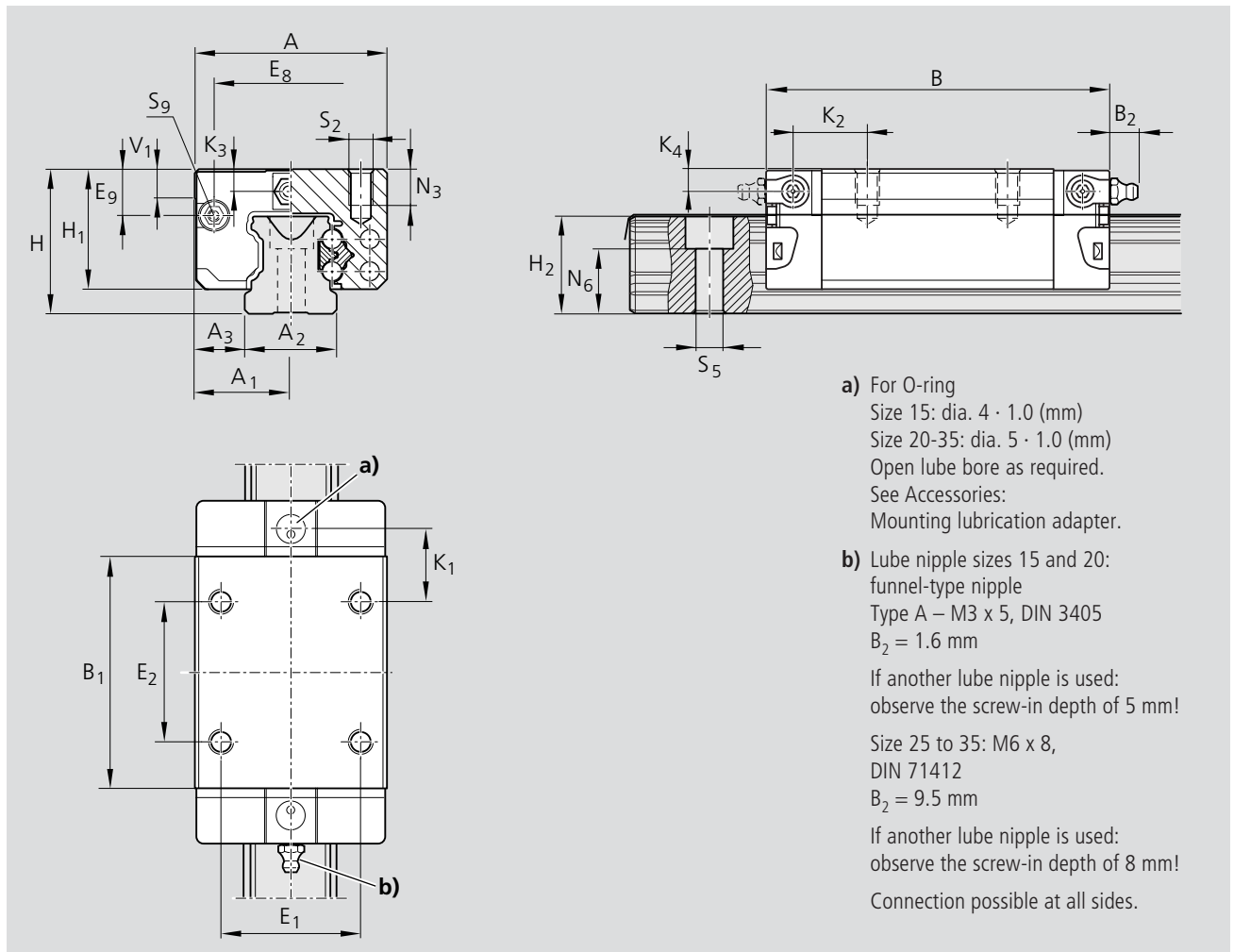

Size	Dimensions (mm)																		
	A	A ₁	A ₂	A ₃	B	B ₁	H	H ₁	H ₂ ¹⁾	H ₂ ²⁾	V ₁	E ₁	E ₂	E ₈	E ₉	K ₁	K ₂	K ₃	K ₄
15	34	17	15	9.5	58.2	39.2	24	19.90	16.30	16.20	5.0	26	26	24.55	6.70	10.00	11.60	3.20	3.20
20	44	22	20	12.0	75.0	49.6	30	25.35	20.75	20.55	6.0	32	36	32.50	7.30	13.80	13.80	3.35	3.35
25	48	24	23	12.5	86.2	57.8	36	29.90	24.45	24.25	7.5	35	35	38.30	11.50	17.45	18.60	5.50	5.50
30	60	30	28	16.0	97.7	67.4	42	35.35	28.55	28.35	7.0	40	40	48.40	14.60	20.00	21.70	6.05	6.05
35	70	35	34	18.0	110.5	77.0	48	40.40	32.15	31.85	8.0	50	50	58.00	17.35	20.50	22.00	6.90	6.90

¹⁾ Dimension H₂ with rail seal cover strip

²⁾ Dimension H₂ without rail seal cover strip

Size	Dimensions (mm)						Mass (kg)	Load capacities (N)				Moments (Nm)			
	N ₃	N ₆ ^{±0.5}	S ₂	S ₅	S ₉	C		M _t		M _L		M _{L0}			
						dyn.		C ₀ stat.	dyn.	M _{t0} stat.	dyn.	stat.	dyn.	stat.	
15	6.0	10.65	M4	4.4	M2.5-3.5 deep	0.15	5 300	9 100	50	88	27	48			
20	7.5	13.55	M5	6.0	M3-5 deep	0.35	12 700	16 500	160	210	88	110			
25	9.0	15.55	M6	7.0	M3-5 deep	0.45	15 500	20 600	210	290	120	160			
30	12.0	17.35	M8	9.0	M3-5 deep	1.80	21 500	28 000	360	490	190	250			
35	13.0	20.85	M8	9.0	M3-5 deep	1.15	28 500	36 700	600	780	300	380			

Determination of the dynamic of the load capacities and moments is based on 100,000 m of stroke travel, however, only 50,000 m are often actually stipulated. Comparison: Value C, M_t and M_L per table multiplied by 1.26.

Product Overview Standard Guide Rails

- Top rigidity in all load directions
- High torque load capacity
- Guide rails in accuracy class H also available as hard chromium-plated
- Proven rail seal cover strip for guide rail mounting holes:
- *One* cover for all holes
- Made of corrosion-resistant spring steel
- DIN EN 10088
- Easy, secure mounting
- Clip on and fasten

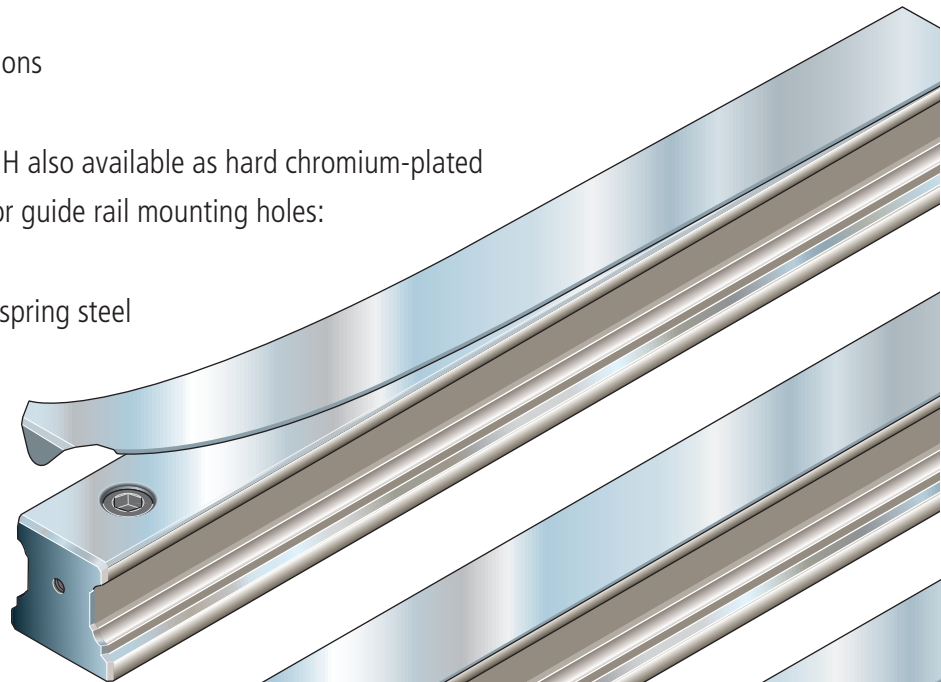

Guide rails with rail seal cover strip and aluminum strip holder

- Without front face threaded mounting holes (not required)

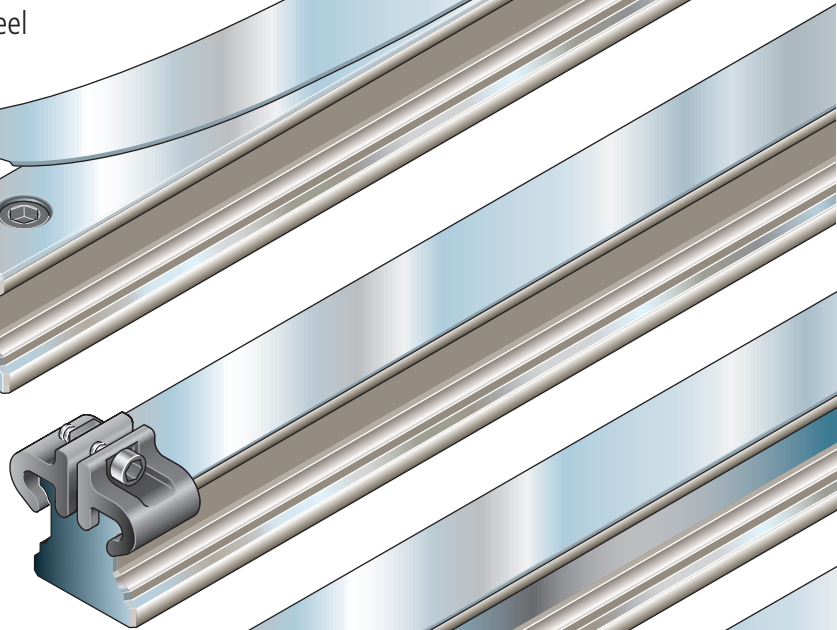

Guide rail seal cover strip and plastic protective caps

- With front face threaded mounting holes

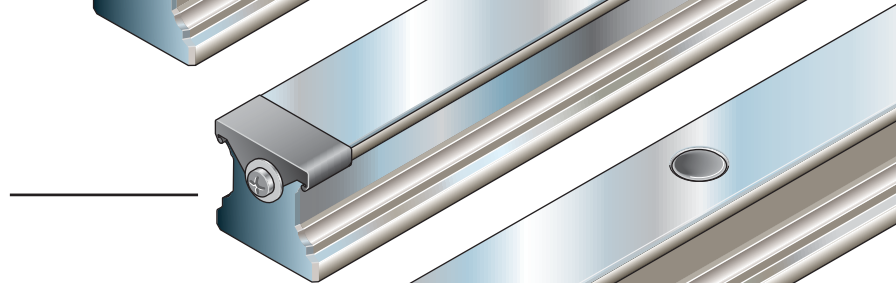

Guide rails with plastic hole plugs

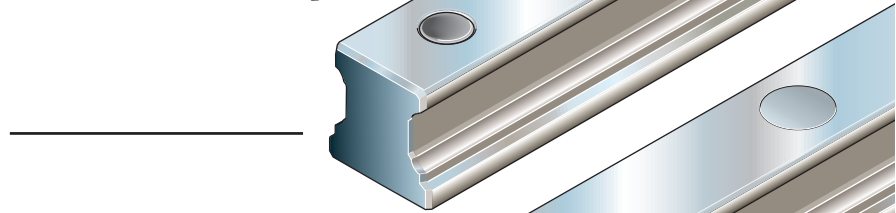

Guide rails with steel hole plugs

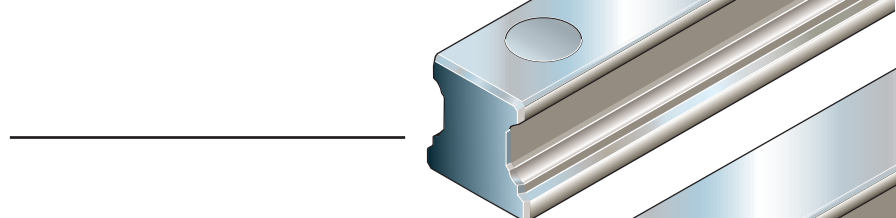

Guide rails for mounting from below



Ordering Example, Standard Guide Rails

Ordering guide rails with recommended rail length

The following examples apply to all guide rails.

Use the part numbers and dimensions from the corresponding tables.

From desired length to recommended length

$$L = \left(\frac{\text{Desired length } L}{\text{Division } T} \right)^* \cdot T - 4 \text{ mm}$$

* Round to whole numbers

Example:

$$L = \left(\frac{1660 \text{ mm}}{80 \text{ mm}} \right) \cdot 80 \text{ mm} - 4 \text{ mm}$$

$$L = 21 \cdot 80 \text{ mm} - 4 \text{ mm}$$

$$L = 1676 \text{ mm}$$

Size	Accuracy class	Guide rail		Spacing T (mm)	Recommended rail length Number of holes n_B / Rail length L (mm)
		one-part Part number, Rail length L (mm)	composite Part number, Number of sections Rail length L (mm)		
15	N	R1605 164 31,.....	R1605 164 3,.....	60	From 2/ 116 to 40/ 2396 per formula $L = n_B \cdot T - 4$ Additional: 2/ 84 2/ 90 2/ 100
	H	R1605 163 31,.....	R1605 163 3,.....		
	P	R1605 162 31,.....	R1605 162 3,.....		
	SP	R1605 161 31,.....	R1605 161 3,.....		
	UP	R1605 169 31,.....	R1605 169 3,.....		
20	N	R1605 864 31,.....	R1605 864 3,.....	60	From 2/ 116 to 55/ 3296 per formula $L = n_B \cdot T - 4$ Additional: 2/ 90 2/ 100
	H	R1605 863 31,.....	R1605 863 3,.....		
	P	R1605 862 31,.....	R1605 862 3,.....		
	SP	R1605 861 31,.....	R1605 861 3,.....		
	UP	R1605 869 31,.....	R1605 869 3,.....		
25	N	R1605 264 31,.....	R1605 264 3,.....	60	From 2/ 116 to 64/ 3836 per formula $L = n_B \cdot T - 4$
	H	R1605 263 31,.....	R1605 263 3,.....		
	P	R1605 262 31,.....	R1605 262 3,.....		
	SP	R1605 261 31,.....	R1605 261 3,.....		
	UP	R1605 269 31,.....	R1605 269 3,.....		
30	N	R1605 764 31,.....	R1605 764 3,.....	80	From 2/ 156 to 48/ 3836 per formula $L = n_B \cdot T - 4$
	H	R1605 763 31,.....	R1605 763 3,.....		
	P	R1605 762 31,.....	R1605 762 3,.....		
	SP	R1605 761 31,.....	R1605 761 3,.....		
	UP	R1605 769 31,.....	R1605 769 3,.....		
35	N	R1605 364 61,.....	R1605 364 6,.....	80	From 2/ 156 to 48/ 3836 per formula $L = n_B \cdot T - 4$
	H	R1605 363 61,.....	R1605 363 6,.....		
	P	R1605 362 61,.....	R1605 362 6,.....		
	SP	R1605 361 61,.....	R1605 361 6,.....		
	UP	R1605 369 61,.....	R1605 369 6,.....		

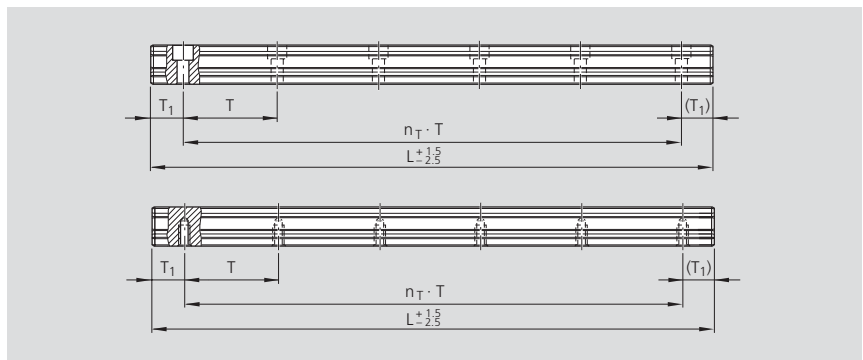

$L = n_B \cdot T - 4$ or $L = n_T \cdot T + 2 \cdot T_{1S}$	$L = \text{rail length (mm)}$ $T = \text{spacing}^*) \text{ (mm)}$ $T_{1S} = \text{preferred dimension}^*) \text{ (mm)}$ $n_B = \text{number of holes per row}$ $n_T = \text{number of spaces}$ *) values, see table
-------------------------------------------------------------------	-------------------------------------------------------------------------------------------------------------------------------------------------------------------------------------------------------------------------------------

Ordering guide rails with intermediate rail length

Calculation of rail length L and ordering examples:

- The preferred dimension is T_{1S}
- If preferred dimension T_{1S} is cannot be used:
 - Select an end space T_1 between T_{1S} and $T_{1 \min}$
 - Do not go below the minimum spacing $T_{1 \min}$!

Note

- $T_1, T_{1 \min}, T_{1S}$ are the same at either end of the rail.

Ordering example 1 (up to L_{\max}):

Guide rail size 35 with rail seal cover strip and strip holder, accuracy class H, rail length 1676 mm,

($20 \cdot T$, preferred dimension $T_{1S} = 38$ mm; number of holes $n_B = 21$)

Ordering data:

Part number, length (mm)

$T_1 / n_T \cdot T / T_1$ (mm)

R1605 333 61, 1676 mm

38 / 20 · 80 / 38 mm

Ordering example 2 (over L_{\max}):

Guide rail size 35 with rail seal cover strip and strip holder, accuracy class H, rail length 5036 mm, 2 sections

($62 \cdot T$, preferred dimension $T_{1S} = 38$ mm; number of holes $n_B = 63$)

Ordering data:

Part number and number of sections, length (mm)

$T_1 / n_T \cdot T / T_1$ (mm)

R1605 333 62, 5036 mm

38 / 62 · 80 / 38 mm

Rail lengths above L_{\max} are made up of fitted rail sections mounted end to end.

Standard Guide Rails

Guide rails R1605 .3. ..

For mounting from above,
with rail seal and strip holder

- Sturdy aluminum strip holder
- Guide rail without front face threaded mounting holes (threaded mounting holes not required for strip holder)

Note

The guide rails are also available as composite rails, see ordering examples.

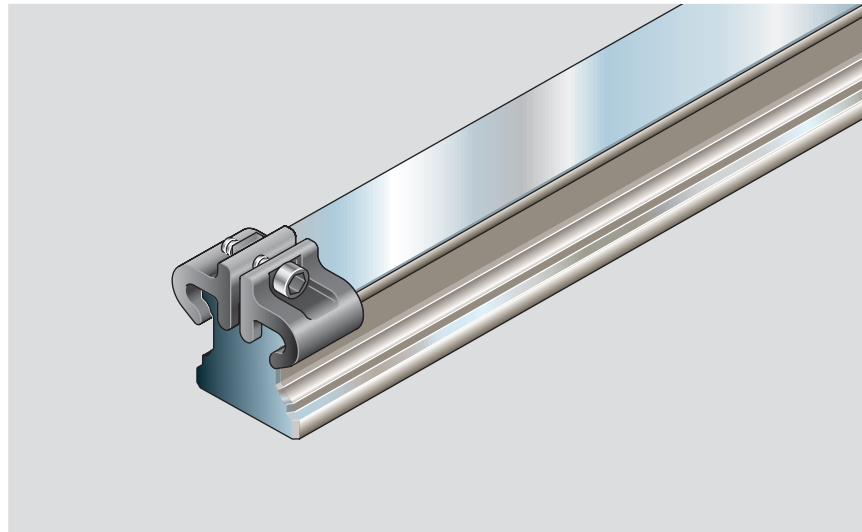

Part numbers and rail lengths

Size	Accuracy class	Guide Rail		Spacing T	Recommended Rail Length Number of holes nB / Rail Length L (mm)
		single part Part number, Rail length L (mm)	composite Part number, Number of sections, Rail length L (mm)		
15	N	R1605 134 31,....	R1605 134 3,....	60	From 2/ 116 to 40/ 2396 per formula L = nB · T – 4 Additional: 2/ 84 2/ 90 2/ 100
	H	R1605 133 31,....	R1605 133 3,....		
	P	R1605 132 31,....	R1605 132 3,....		
	SP	R1605 131 31,....	R1605 131 3,....		
	UP	R1605 139 31,....	R1605 139 3,....		
20	N	R1605 834 31,....	R1605 834 3,....	60	From 2/ 116 to 55/ 3296 per formula L = nB · T – 4 Additional: 2/ 90 2/ 100
	H	R1605 833 31,....	R1605 833 3,....		
	P	R1605 832 31,....	R1605 832 3,....		
	SP	R1605 831 31,....	R1605 831 3,....		
	UP	R1605 839 31,....	R1605 839 3,....		
25	N	R1605 234 31,....	R1605 234 3,....	60	From 2/ 116 to 64/ 3836 per formula L = nB · T – 4
	H	R1605 233 31,....	R1605 233 3,....		
	P	R1605 232 31,....	R1605 232 3,....		
	SP	R1605 231 31,....	R1605 231 3,....		
	UP	R1605 239 31,....	R1605 239 3,....		
30	N	R1605 734 31,....	R1605 734 3,....	80	From 2/ 156 to 48/ 3836 per formula L = nB · T – 4
	H	R1605 733 31,....	R1605 733 3,....		
	P	R1605 732 31,....	R1605 732 3,....		
	SP	R1605 731 31,....	R1605 731 3,....		
	UP	R1605 739 31,....	R1605 739 3,....		
35	N	R1605 334 61,....	R1605 334 6,....	80	From 2/ 156 to 48/ 3836 per formula L = nB · T – 4
	H	R1605 333 61,....	R1605 333 6,....		
	P	R1605 332 61,....	R1605 332 6,....		
	SP	R1605 331 61,....	R1605 331 6,....		
	UP	R1605 339 61,....	R1605 339 6,....		
45	N	R1605 434 61,....	R1605 434 6,....	105	From 4/ 416 to 37/ 3881 per formula L = nB · T – 4
	H	R1605 433 61,....	R1605 433 6,....		
	P	R1605 432 61,....	R1605 432 6,....		
	SP	R1605 431 61,....	R1605 431 6,....		
	UP	R1605 439 61,....	R1605 439 6,....		
55	N	R1605 534 61,....	R1605 534 6,....	120	From 6/ 716 to 32/ 3836 per formula L = nB · T – 4
	H	R1605 533 61,....	R1605 533 6,....		
	P	R1605 532 61,....	R1605 532 6,....		
	SP	R1605 531 61,....	R1605 531 6,....		
	UP	R1605 539 61,....	R1605 539 6,....		
65	N	R1605 634 61,....	R1605 634 6,....	150	From 8/ 1196 to 25/ 3746 per formula L = nB · T – 4
	H	R1605 633 61,....	R1605 633 6,....		
	P	R1605 632 61,....	R1605 632 6,....		
	SP	R1605 631 61,....	R1605 631 6,....		
	UP	R1605 639 61,....	R1605 639 6,....		

Dimensions and masses

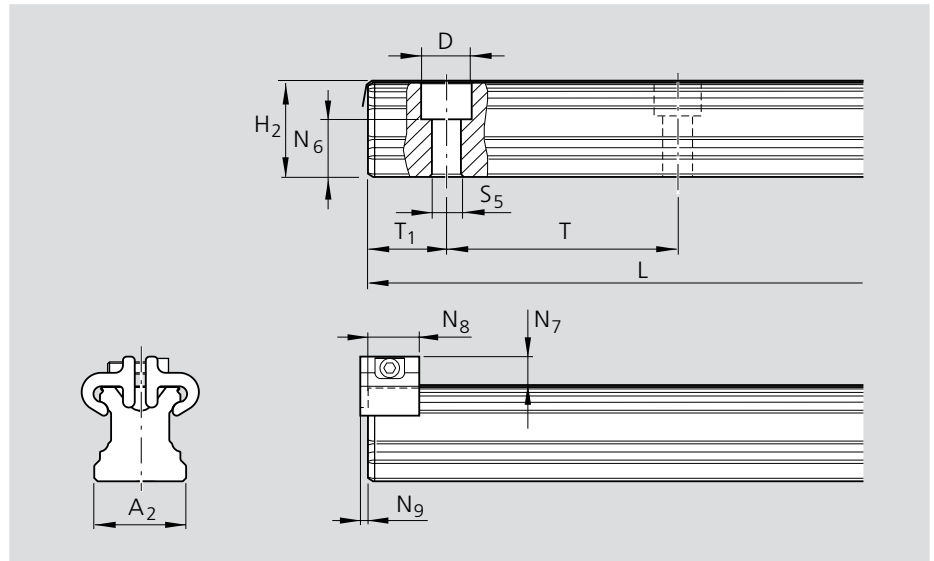

Size	Dimension (mm)											Mass (kg/m)	
	A ₂	H ₂ ¹⁾	N ₆ ^{±0.5}	N ₇ ²⁾	N ₈	N ₉	D	S ₅	T _{1S-1.0} ^{+0.5 3)}	T _{1 min}	T		L _{max} ⁴⁾
15	15	16.3	10.3	7.3	12.0	2.0	7.4	4.4	28.0	12	60	4000	1.4
20	20	20.7	13.2	7.1	12.0	2.0	9.4	6.0	28.0	13	60	4000	2.4
25	23	24.4	15.2	8.2	13.0	2.0	11.0	7.0	28.0	13	60	4000	3.2
30	28	28.5	17.0	8.7	13.0	2.0	15.0	9.0	38.0	16	80	4000	5.0
35	34	32.15	20.5	11.7	16.0	2.2	15.0	9.0	38.0	16	80	4000	6.8
45	45	40.15	23.5	12.5	18.0	2.2	20.0	14.0	50.5	18	105	4000	10.5
55	53	48.15	29.0	14.0	17.0	3.2	24.0	16.0	58.0	20	120	4000	16.2
65	63	60.15	38.5	15.0	17.0	3.2	26.0	18.0	73.0	21	150	4000	22.4

¹⁾ Dimension H₂ with rail seal cover strip

²⁾ Dimension N₇ with rail seal cover strip

³⁾ Preferred dimension

⁴⁾ For sizes 20 – 45, one-piece guide rails up to approx. 6000 mm in length can be supplied in special cases.

Standard Guide Rails

Guide rails R1605 .6. ...

For mounting from above,
with rail seal and screw-down
protective caps

- Plastic protective caps
- Guide rail with front face threaded mounting holes

Note

The guide rails are also available as composite rails, see ordering examples.

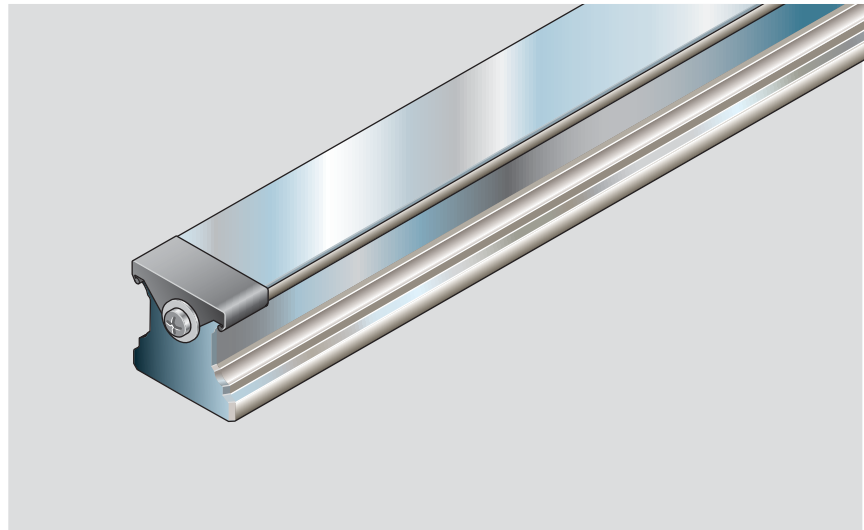

Part numbers and rail lengths

Size	Accuracy class	Guide rail		Spacing T (mm)	Recommended rail length Number of holes n _B / Rail length L (mm)
		one-part Part number, Rail length L (mm)	composite Part number, Number of sections Rail length L (mm)		
15	N	R1605 164 31,....	R1605 164 3,....	60	From 2/ 116 to 40/ 2396 per formula L = nB · T - 4 Additional: 2/ 84 2/ 90 2/ 100
	H	R1605 163 31,....	R1605 163 3,....		
	P	R1605 162 31,....	R1605 162 3,....		
	SP	R1605 161 31,....	R1605 161 3,....		
	UP	R1605 169 31,....	R1605 169 3,....		
20	N	R1605 864 31,....	R1605 864 3,....	60	From 2/ 116 to 55/ 3296 per formula L = nB · T - 4 Additional: 2/ 90 2/ 100
	H	R1605 863 31,....	R1605 863 3,....		
	P	R1605 862 31,....	R1605 862 3,....		
	SP	R1605 861 31,....	R1605 861 3,....		
	UP	R1605 869 31,....	R1605 869 3,....		
25	N	R1605 264 31,....	R1605 264 3,....	60	From 2/ 116 to 64/ 3836 per formula L = nB · T - 4
	H	R1605 263 31,....	R1605 263 3,....		
	P	R1605 262 31,....	R1605 262 3,....		
	SP	R1605 261 31,....	R1605 261 3,....		
	UP	R1605 269 31,....	R1605 269 3,....		
30	N	R1605 764 31,....	R1605 764 3,....	80	From 2/ 156 to 48/ 3836 per formula L = nB · T - 4
	H	R1605 763 31,....	R1605 763 3,....		
	P	R1605 762 31,....	R1605 762 3,....		
	SP	R1605 761 31,....	R1605 761 3,....		
	UP	R1605 769 31,....	R1605 769 3,....		
35	N	R1605 364 61,....	R1605 364 6,....	80	From 2/ 156 to 48/ 3836 per formula L = nB · T - 4
	H	R1605 363 61,....	R1605 363 6,....		
	P	R1605 362 61,....	R1605 362 6,....		
	SP	R1605 361 61,....	R1605 361 6,....		
	UP	R1605 369 61,....	R1605 369 6,....		
45	N	R1605 464 61,....	R1605 464 6,....	105	From 4/ 416 to 37/ 3881 per formula L = nB · T - 4
	H	R1605 463 61,....	R1605 463 6,....		
	P	R1605 462 61,....	R1605 462 6,....		
	SP	R1605 461 61,....	R1605 461 6,....		
	UP	R1605 469 61,....	R1605 469 6,....		
55	N	R1605 564 61,....	R1605 564 6,....	120	From 6/ 716 to 32/ 3836 per formula L = nB · T - 4
	H	R1605 563 61,....	R1605 563 6,....		
	P	R1605 562 61,....	R1605 562 6,....		
	SP	R1605 561 61,....	R1605 561 6,....		
	UP	R1605 569 61,....	R1605 569 6,....		
65	N	R1605 664 61,....	R1605 664 6,....	150	From 8/ 1196 to 25/ 3746 per formula L = nB · T - 4
	H	R1605 663 61,....	R1605 663 6,....		
	P	R1605 662 61,....	R1605 662 6,....		
	SP	R1605 661 61,....	R1605 661 6,....		
	UP	R1605 669 61,....	R1605 669 6,....		

Dimensions and masses

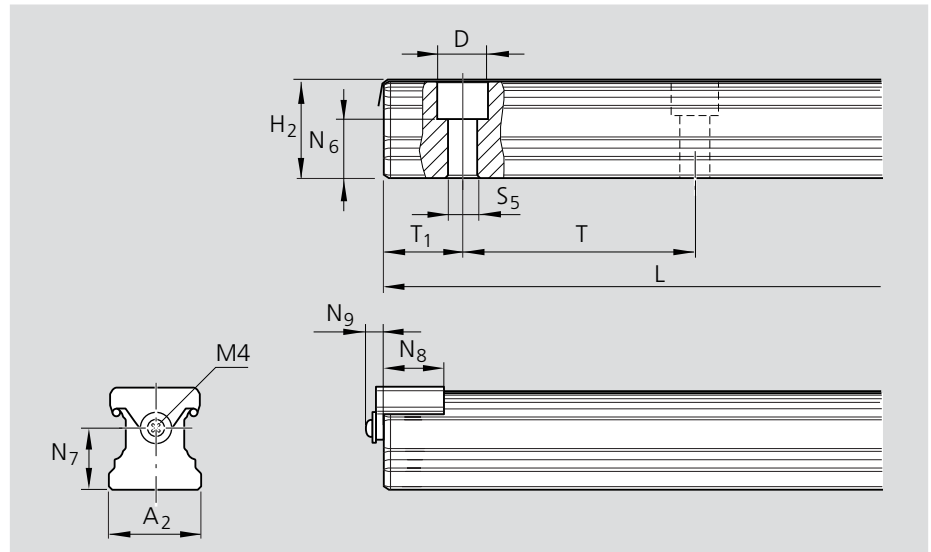

Size	Dimension (mm)												Mass (kg/m)
	A ₂	H ₂ ¹⁾	N ₆ ^{±0.5}	N ₇ ²⁾	N ₈	N ₉	D	S ₅	T ₁₅ ^{+0.5³⁾}	T _{1 min}	T	L _{max} ⁴⁾	
15	15	16.3	10.3	9.8	14.0	6.5	7.4	4.4	28.0	12	60	4000	1.4
20	20	20.7	13.2	13.0	14.0	6.5	9.4	6.0	28.0	13	60	4000	2.4
25	23	24.4	15.2	15.0	15.2	6.5	11.0	7.0	28.0	13	60	4000	3.2
30	28	28.5	17.0	18.0	15.2	7.0	15.0	9.0	38.0	16	80	4000	5.0
35	34	32.15	20.5	22.0	18.0	7.0	15.0	9.0	38.0	16	80	4000	6.8
45	45	40.15	23.5	30.0	20.0	7.0	20.0	14.0	50.5	18	105	4000	10.5
55	53	48.15	29.0	30.0	20.0	7.0	24.0	16.0	58.0	20	120	4000	16.2
65	63	60.15	38.5	40.0	20.0	7.0	26.0	18.0	73.0	21	150	4000	22.4

¹⁾ Dimension H₂ with rail seal cover strip

²⁾ Dimension N₇ with rail seal cover strip

³⁾ Preferred dimension

⁴⁾ For sizes 20 – 45, one-piece guide rails up to approx. 6000 mm in length can be supplied in special cases.

Standard Guide Rails

Guide rails R1605 .0. ..

For mounting from above,
with plastic mounting hole plugs
(supplied)

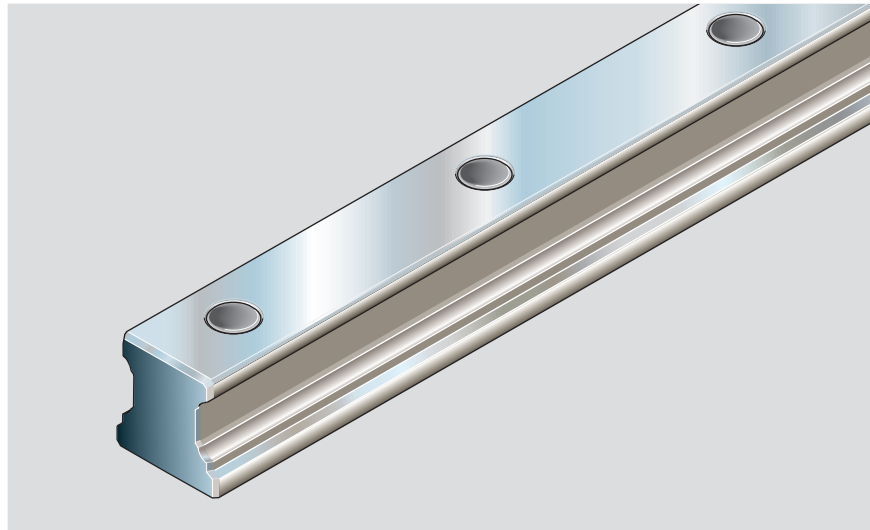

Part numbers and rail lengths

Size	Accuracy class	Guide rail		Spacing T (mm)	Recommended rail length Number of holes n _B / Rail length L (mm)
		one-part Part number, Rail length L (mm)	composite Part number, Number of sections Rail length L (mm)		
15	N	R1605 104 31,.....	R1605 104 3,.....	60	From 2/ 116 to 40/ 2396 per formula L = n_B · T - 4 Additional standard lengths: 2/ 80 2/ 90 2/ 100
	H	R1605 103 31,.....	R1605 103 3,.....		
	P	R1605 102 31,.....	R1605 102 3,.....		
	SP	R1605 101 31,.....	R1605 101 3,.....		
	UP	R1605 109 31,.....	R1605 109 3,.....		
20	N	R1605 804 31,.....	R1605 804 3,.....	60	From 2/ 116 to 55/ 3296 per formula L = n_B · T - 4 Additional standard lengths: 2/ 90 2/ 100 5/ 280 8/460
	H	R1605 803 31,.....	R1605 803 3,.....		
	P	R1605 802 31,.....	R1605 802 3,.....		
	SP	R1605 801 31,.....	R1605 801 3,.....		
	UP	R1605 809 31,.....	R1605 809 3,.....		
25	N	R1605 204 31,.....	R1605 204 3,.....	60	From 2/ 116 to 64/ 3836 per formula L = n_B · T - 4 Additional standard lengths: 2/ 100 5/ 280 6/ 340 7/400 8/460
	H	R1605 203 31,.....	R1605 203 3,.....		
	P	R1605 202 31,.....	R1605 202 3,.....		
	SP	R1605 201 31,.....	R1605 201 3,.....		
	UP	R1605 209 31,.....	R1605 209 3,.....		
30	N	R1605 704 31,.....	R1605 704 3,.....	80	From 2/ 156 to 48/ 3836 per formula L = n_B · T - 4 Additional standard lengths: 6/ 440 7/ 520 8/ 600
	H	R1605 703 31,.....	R1605 703 3,.....		
	P	R1605 702 31,.....	R1605 702 3,.....		
	SP	R1605 701 31,.....	R1605 701 3,.....		
	UP	R1605 709 31,.....	R1605 709 3,.....		
35	N	R1605 304 31,.....	R1605 304 3,.....	80	From 2/ 156 to 48/ 3836 per formula L = n_B · T - 4 Additional standard lengths: 9/ 680 10/ 760 13/ 1000 15/1160 16/1240 17/1320
	H	R1605 303 31,.....	R1605 303 3,.....		
	P	R1605 302 31,.....	R1605 302 3,.....		
	SP	R1605 301 31,.....	R1605 301 3,.....		
	UP	R1605 309 31,.....	R1605 309 3,.....		
45	N	R1605 404 31,.....	R1605 404 3,.....	105	From 4/ 416to 37/ 3881 per formula L = n_B · T - 4 Additional standard lengths: 9/ 885 11/ 1095 12/ 1200
	H	R1605 403 31,.....	R1605 403 3,.....		
	P	R1605 402 31,.....	R1605 402 3,.....		
	SP	R1605 401 31,.....	R1605 401 3,.....		
	UP	R1605 409 31,.....	R1605 409 3,.....		
55	N	R1605 504 31,.....	R1605 504 3,.....	120	From 6/ 716 to 32/ 3836 per formula L = n_B · T - 4 Additional standard lengths: 12/ 1380 13/1500
	H	R1605 503 31,.....	R1605 503 3,.....		
	P	R1605 502 31,.....	R1605 502 3,.....		
	SP	R1605 501 31,.....	R1605 501 3,.....		
	UP	R1605 509 31,.....	R1605 509 3,.....		
65	N	R1605 604 31,.....	R1605 604 3,.....	150	From 8/ 1196 to 25/ 3746 per formula L = n_B · T - 4
	H	R1605 603 31,.....	R1605 603 3,.....		
	P	R1605 602 31,.....	R1605 602 3,.....		
	SP	R1605 601 31,.....	R1605 601 3,.....		
	UP	R1605 609 31,.....	R1605 609 3,.....		

Dimensions and masses

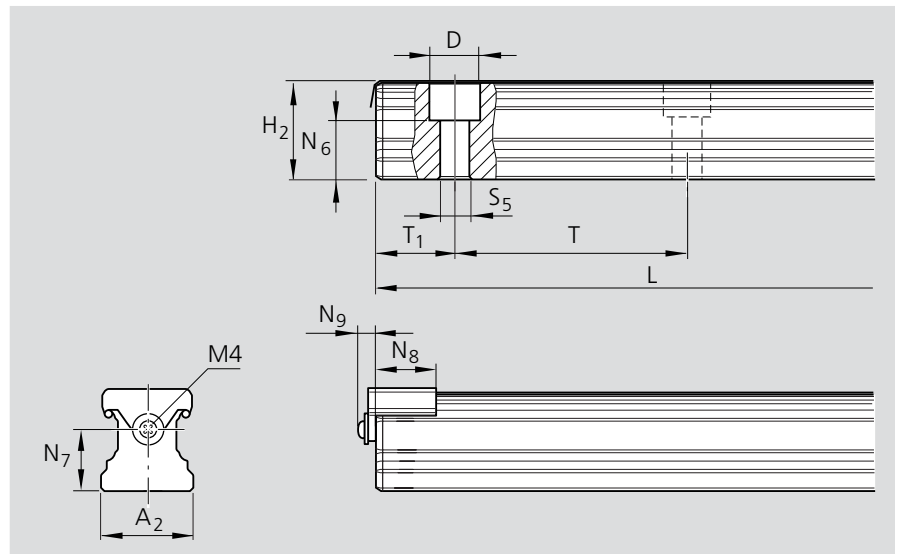

Size	Dimensions (mm)									Mass (kg/m)
	A ₂	H ₂ ¹⁾	N ₆ ^{±0.5}	D	S ₅	T ₁₅ ^{+0.5²⁾-1}	T _{1 min}	T	L _{max} ³⁾	
15	15	16.20	10.3	7.4	4.4	28.0	10	60	4000	1.4
20	20	20.55	13.2	9.4	6.0	28.0	10	60	4000	2.4
25	23	24.25	15.2	11.0	7.0	28.0	10	60	4000	3.2
30	28	28.35	17.0	15.0	9.0	38.0	12	80	4000	5.0
35	34	31.85	20.5	15.0	9.0	38.0	12	80	4000	6.8
45	45	39.85	23.5	20.0	14.0	50.5	16	105	4000	10.5
55	53	47.85	29.0	24.0	16.0	58.0	18	120	4000	16.2
65	63	59.85	38.5	26.0	18.0	73.0	20	150	4000	22.4

¹⁾ Dimension H₂ without rail seal cover strip

²⁾ Preferred dimension

³⁾ For sizes 20 – 45, one-piece guide rails up to approx. 6000 mm in length can be supplied in special cases.

Standard Guide Rails

Guide rails R1606 .5. ..

For mounting from above,
with steel mounting hole plugs
(not supplied)

Order steel mounting hole plugs and
mounting tool separately.

Observe the mounting instructions for
steel mounting hole plugs.

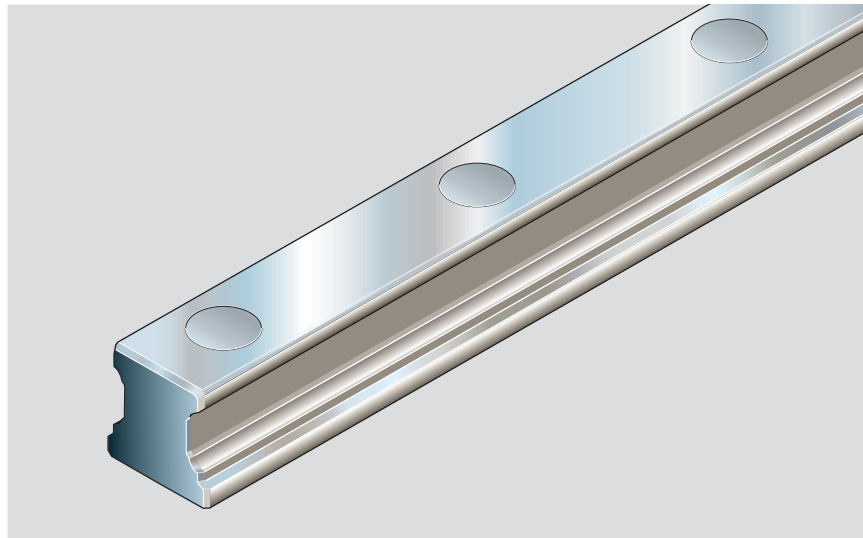

Part numbers and rail lengths

Size	Accuracy class	Guide rail		Spacing T (mm)	Recommended rail length Number of holes n_B / Rail length L (mm)
		one-part Part number, Rail length L (mm)	composite Part number, Number of sections Rail length L (mm)		
25	N	R1606 254 31,....	R1606 254 3,....	60	From 2/ 116 to 64/ 3836 per formula L = $n_B \cdot T - 4$
	H	R1606 253 31,....	R1606 253 3,....		
	P	R1606 252 31,....	R1606 252 3,....		
	SP	R1606 251 31,....	R1606 251 3,....		
30	N	R1606 754 31,....	R1606 754 3,....	80	From 2/ 156 to 48/ 3836 per formula L = $n_B \cdot T - 4$
	H	R1606 753 31,....	R1606 753 3,....		
	P	R1606 752 31,....	R1606 752 3,....		
	SP	R1606 751 31,....	R1606 751 3,....		
35	N	R1606 354 31,....	R1606 354 3,....	80	From 2/ 156 to 48/ 3836 per formula L = $n_B \cdot T - 4$
	H	R1606 353 31,....	R1606 353 3,....		
	P	R1606 352 31,....	R1606 352 3,....		
	SP	R1606 351 31,....	R1606 351 3,....		
45	N	R1606 454 31,....	R1606 454 3,....	105	From 4/ 416 to 37/ 3881 per formula L = $n_B \cdot T - 4$
	H	R1606 453 31,....	R1606 453 3,....		
	P	R1606 452 31,....	R1606 452 3,....		
	SP	R1606 451 31,....	R1606 451 3,....		
55	N	R1606 554 31,....	R1606 554 3,....	120	From 6/ 716 to 32/ 3836 per formula L = $n_B \cdot T - 4$
	H	R1606 553 31,....	R1606 553 3,....		
	P	R1606 552 31,....	R1606 552 3,....		
	SP	R1606 551 31,....	R1606 551 3,....		
65	N	R1606 654 31,....	R1606 654 3,....	150	From 8/ 1196 to 25/ 3746 per formula L = $n_B \cdot T - 4$
	H	R1606 653 31,....	R1606 653 3,....		
	P	R1606 652 31,....	R1606 652 3,....		
	SP	R1606 651 31,....	R1606 651 3,....		

Dimensions and masses

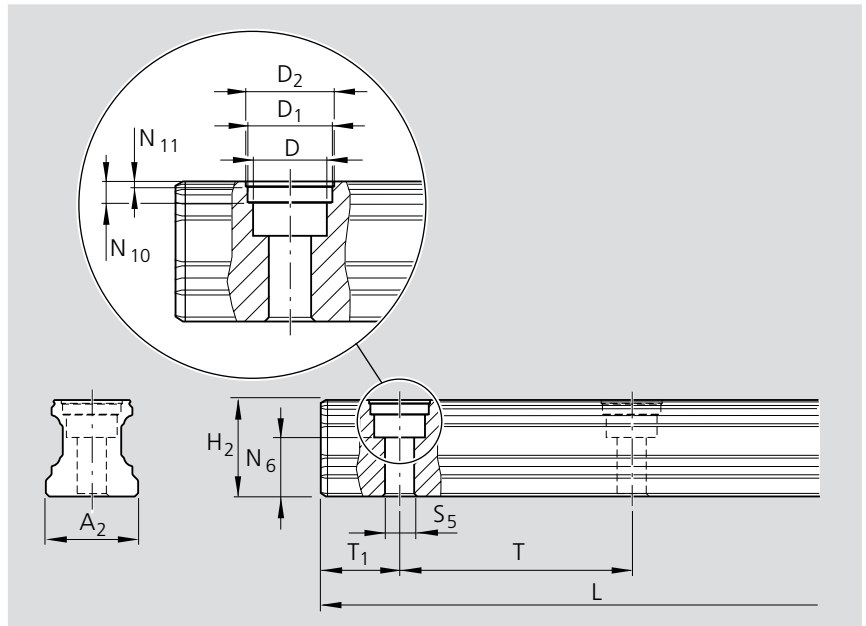

Size	Dimensions (mm)							
	A ₂	H ₂	N ₆ ^{±0.5}	D	N ₁₀	D ₁	N ₁₁	D ₂
25	23	24.25	15.2	11.0	3.7	12.55	0.9	13.0
30	28	28.35	17.0	15.0	3.6	17.55	0.9	18.0
35	34	31.85	20.5	15.0	3.6	17.55	0.9	18.0
45	45	39.85	23.5	20.0	8.0	22.55	1.45	23.0
55	53	47.85	29.0	24.0	8.0	27.55	1.45	28.0
65	63	59.85	38.5	26.0	8.0	29.55	1.45	30.0

Size	Dimensions (mm)					Mass (kg/m)
	S ₅	T ₁₅ ^{+0.5} _{-1.0} ¹⁾	T _{1 min}	T	L _{max}	
25	7.0	28.0	13	60	4000	3.2
30	9.0	38.0	16	80	4000	5.0
35	9.0	38.0	16	80	4000	6.8
45	14.0	50.5	18	105	4000	10.5
55	16.0	58.0	20	120	4000	16.2
65	18.0	73.0	21	150	4000	22.4

¹⁾ Preferred dimension

Steel mounting hole plugs

Size	Steel mounting hole plugs Part numbers
25	R1606 200 75
30	R1606 300 75
35	R1606 300 75
45	R1606 400 75
55	R1606 500 75
65	R1606 600 75

Standard Guide Rails

Guide rail R1607

For mounting from below

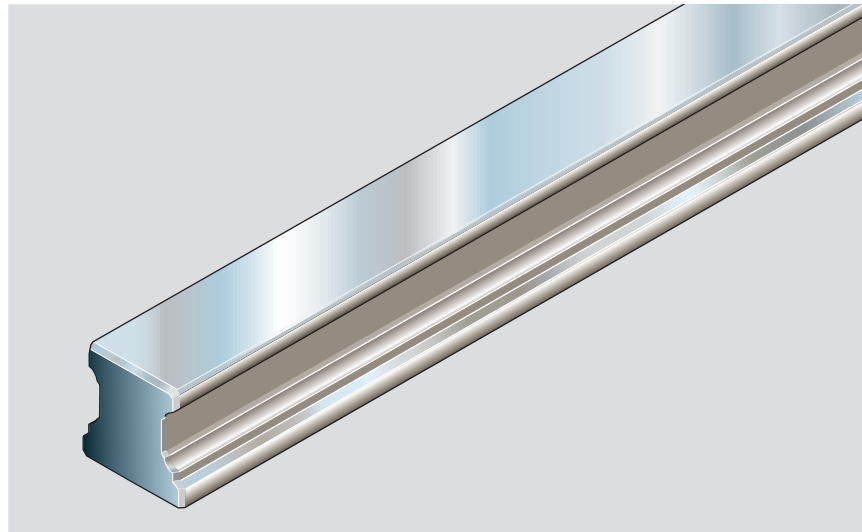

Part numbers and rail lengths

Size	Accuracy class	Guide rail		Spacing T (mm)	Recommended rail length Number of holes n _B / Rail length L (mm)
		one-part Part number, Rail length L (mm)	composite Part number, Number of sections Rail length L (mm)		
15	N	R1607 104 31,.....	R1607 104 3,.....	60	From 2/ 116 to 40/ 2396 per formula L = nB · T - 4 Additional: 2/ 80 2/ 90 2/ 100
	H	R1607 103 31,.....	R1607 103 3,.....		
	P	R1607 102 31,.....	R1607 102 3,.....		
	SP	R1607 101 31,.....	R1607 101 3,.....		
	UP	R1607 109 31,.....	R1607 109 3,.....		
20	N	R1607 804 31,.....	R1607 804 3,.....	60	From 2/ 116 to 55/ 3296 per formula L = nB · T - 4 Additional: 2/ 90 2/ 100
	H	R1607 803 31,.....	R1607 803 3,.....		
	P	R1607 802 31,.....	R1607 802 3,.....		
	SP	R1607 801 31,.....	R1607 801 3,.....		
	UP	R1607 809 31,.....	R1607 809 3,.....		
25	N	R1607 204 31,.....	R1607 204 3,.....	60	From 2/ 116 to 64/ 3836 per formula L = nB · T - 4
	H	R1607 203 31,.....	R1607 203 3,.....		
	P	R1607 202 31,.....	R1607 202 3,.....		
	SP	R1607 201 31,.....	R1607 201 3,.....		
	UP	R1607 209 31,.....	R1607 209 3,.....		
30	N	R1607 704 31,.....	R1607 704 3,.....	80	From 2/ 156 to 48/ 3836 per formula L = nB · T - 4
	H	R1607 703 31,.....	R1607 703 3,.....		
	P	R1607 702 31,.....	R1607 702 3,.....		
	SP	R1607 701 31,.....	R1607 701 3,.....		
	UP	R1607 709 31,.....	R1607 709 3,.....		
35	N	R1607 304 31,.....	R1607 304 3,.....	80	From 2/ 156 to 48/ 3836 per formula L = nB · T - 4
	SP	R1607 301 31,.....	R1607 301 3,.....		
	P	R1607 302 31,.....	R1607 302 3,.....		
	H	R1607 303 31,.....	R1607 303 3,.....		
	N	R1607 304 31,.....	R1607 304 3,.....		
45	N	R1607 404 31,.....	R1607 404 3,.....	105	From 4/ 416 to 37/ 3881 per formula L = nB · T - 4
	H	R1607 403 31,.....	R1607 403 3,.....		
	P	R1607 402 31,.....	R1607 402 3,.....		
	SP	R1607 401 31,.....	R1607 401 3,.....		
	UP	R1607 409 31,.....	R1607 409 3,.....		
55	N	R1607 504 31,.....	R1607 504 3,.....	120	From 6/ 716 to 32/ 3836 per formula L = nB · T - 4
	H	R1607 503 31,.....	R1607 503 3,.....		
	P	R1607 502 31,.....	R1607 502 3,.....		
	SP	R1607 501 31,.....	R1607 501 3,.....		
	UP	R1607 509 31,.....	R1607 509 3,.....		
65	N	R1607 604 31,.....	R1607 604 3,.....	150	From 8/ 1196 to 25/ 3746 per formula L = nB · T - 4
	H	R1607 603 31,.....	R1607 603 3,.....		
	P	R1607 602 31,.....	R1607 602 3,.....		
	SP	R1607 601 31,.....	R1607 601 3,.....		
	UP	R1607 609 31,.....	R1607 609 3,.....		

Dimensions and masses

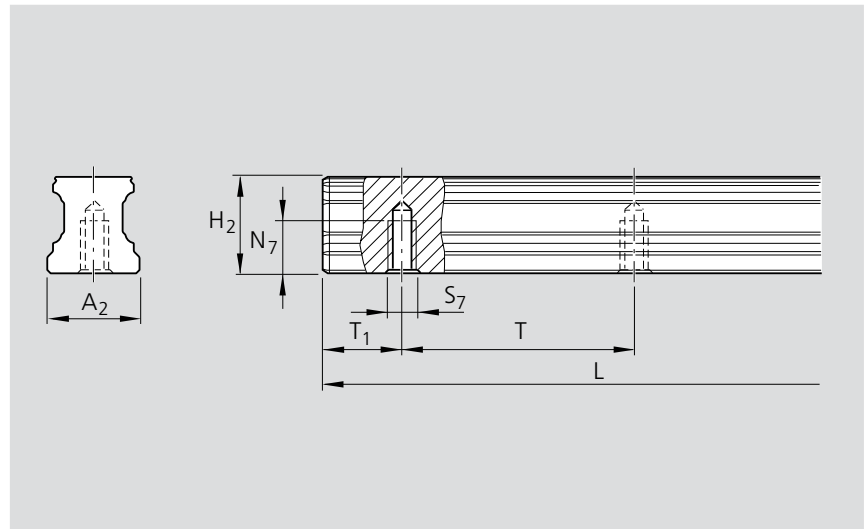

Size	Dimensions (mm)								Mass kg/m
	A_2	H_2	N_7	S_7	$T_{15}^{+0.5^1}_{-1.0}$	T_{1min}	T	$L_{max}^{2)}$	
15	15	16.20	7.5	M5	28.0	10	60	4000	1.4
20	20	20.55	9.0	M6	28.0	10	60	4000	2.4
25	23	24.25	12.0	M6	28.0	10	60	4000	3.2
30	28	28.35	15.0	M8	38.0	12	80	4000	5.0
35	34	31.85	15.0	M8	38.0	12	80	4000	6.8
45	45	39.85	19.0	M12	50.5	16	105	4000	10.5
55	53	47.85	22.0	M14	58.0	18	120	4000	16.2
65	63	59.85	25.0	M16	73.0	20	150	4000	22.4

¹⁾ Preferred dimension

²⁾ For sizes 20 – 45 in accuracy classes N, H and P one-piece guide rails up to approx. 6000 mm in length can be supplied in special cases.

Standard Guide Rails, Hard Chromium-plated

Guide rails

Resist CR

R1645 .33 ..

Hard chromium-plated,
matt silver

For mounting from above,
with rail seal and screw-down
protective caps

- The holes have a chrome coating.
- The end faces of composite rails are chromium-plated.

Versions:

- End faces not chromium-plated (except composite rails):
For part numbers, see table
- End faces chromium-plated:
Part numbers R1645 .33 41
- Composite guide rails are secured on both sides of the butt joint.

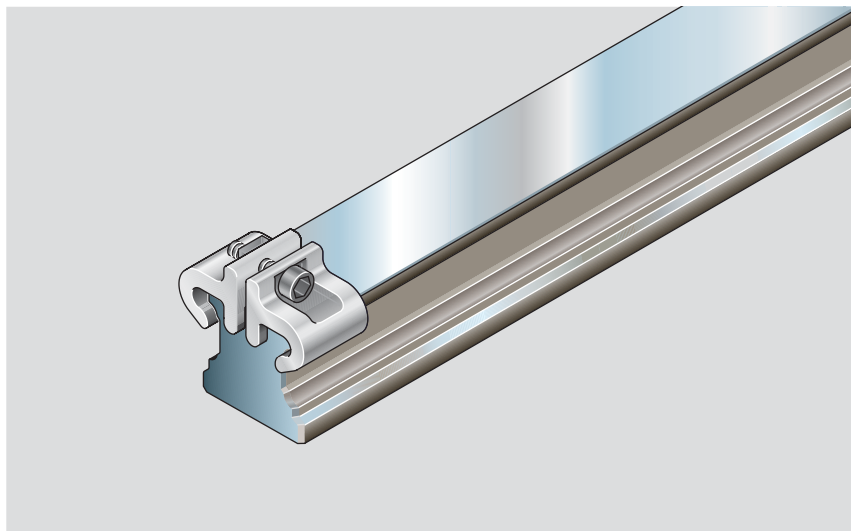

Part numbers and rail lengths

Size	Accuracy class	Guide rail		Spacing T (mm)	Recommended rail length Number of holes n _B / Rail length L (mm)
		one-part Part number, Rail length L (mm)	composite Part number, Number of sections Rail length L (mm)		
15	H	R1645 133 31,....	R1645 133 4,.....	60	From 2/ 116 to 40/ 2396 per formula L = n_B · T - 4 Additional: 2/ 84 2/ 90 2/ 100
20	H	R1645 833 31,....	R1645 833 4,.....	60	From 2/ 116 to 55/ 3296 per formula L = n_B · T - 4 Additional: 2/ 90 2/ 100
25	H	R1645 233 31,....	R1645 233 4,.....	60	From 2/ 116 to 64/ 3836 per formula L = n_B · T - 4
30	H	R1645 733 31,....	R1645 733 4,.....	80	From 2/ 156 to 48/ 3836 per formula L = n_B · T - 4
35	H	R1645 333 61,....	R1645 333 7,.....	80	From 2/ 156 to 48/ 3836 per formula L = n_B · T - 4
45	H	R1645 433 61,....	R1645 433 7,.....	105	From 4/ 416 to 37/ 3881 per formula L = n_B · T - 4
55	H	R1645 533 71,....	R1645 533 7,.....	120	From 6/ 716 to 32/ 3836 per formula L = n_B · T - 4
65	H	R1645 633 71,....	R1645 633 7,.....	150	From 8/ 1196 to 25/ 3746 per formula L = n_B · T - 4

Dimensions and masses

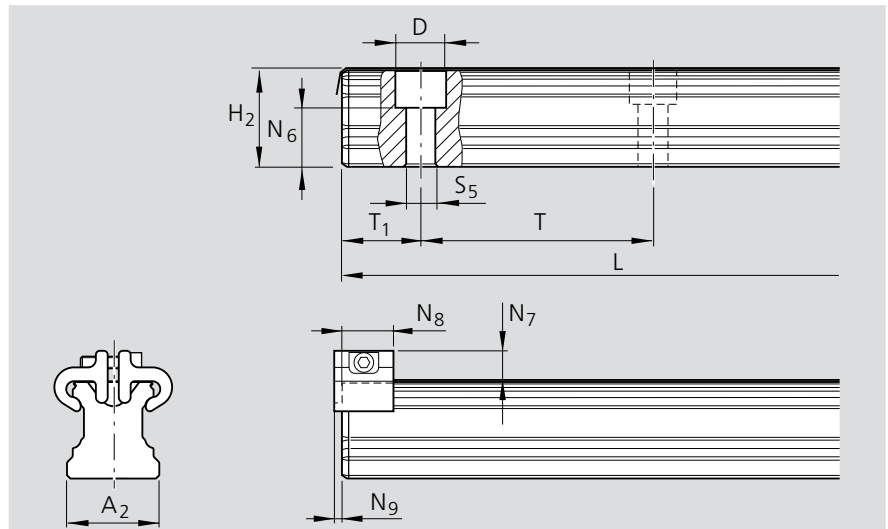

Size	Dimensions (mm)												Mass kg/m
	A ₂	H ₂ ¹⁾	N ₆ ^{±0,5}	N ₇ ²⁾	N ₈	N ₉	D	S ₅	T ₁₅ ^{+0,5} _{-1,0} ³⁾	T _{1 min}	T	L _{max}	
15	15	16.30	10.3	7.3	12.0	2.0	7.4	4.4	28.0	12	60	4000	1.4
20	20	20.75	13.2	7.1	12.0	2.0	9.4	6.0	28.0	13	60	4000	2.4
25	23	24.45	15.2	8.2	13.0	2.0	11.0	7.0	28.0	13	60	4000	3.2
30	28	28.55	17.0	8.7	13.0	2.0	15.0	9.0	38.0	16	80	4000	5.0
35	34	32.15	20.5	11.7	16.0	2.2	15.0	9.0	38.0	16	80	4000	6.8
45	45	40.15	23.5	12.5	18.0	2.2	20.0	14.0	50.5	18	105	4000	10.5
55	53	48.15	29.0	14.0	17.0	3.2	24.0	16.0	58.0	20	120	4000	16.2
65	63	60.15	38.5	15.0	17.0	3.2	26.0	18.0	73.0	21	150	4000	22.4

¹⁾ Dimension H₂ with rail seal cover strip

²⁾ Dimension N₇ without rail seal cover strip

³⁾ Preferred dimension

Recommended runner blocks

Recommended runner block:

Size 15 to 65:

- Runner blocks of accuracy class H to 10 µm clearance

Size 35 to 65:

- Runner blocks of accuracy class H to 0.02 C preload

When using a combination of guide rails and runners block of different accuracy classes, the tolerances for dimensions H and A₃ change.

(Dimensions H and A₃, see sections "Accuracy classes and their tolerances" at the technical data for runner blocks.) Exact values for the desired combinations are available on request.

Standard Guide Rails, Hard Chromium-Plated

Guide rail
Resist CR
R1645 .03 ..
Hard chromium-plated,
matt silver

for mounting from above,
complete with plastic mounting
hole plugs

- The holes have a chrome coating.
- The end faces of composite rails are chromium-plated.

Versions:

- End faces not chromium-plated (except composite rails):
For part numbers, see table
- End faces chromium-plated:
Part numbers 1645 ..3 41
- Composite guide rails are secured on both sides of the butt joint.

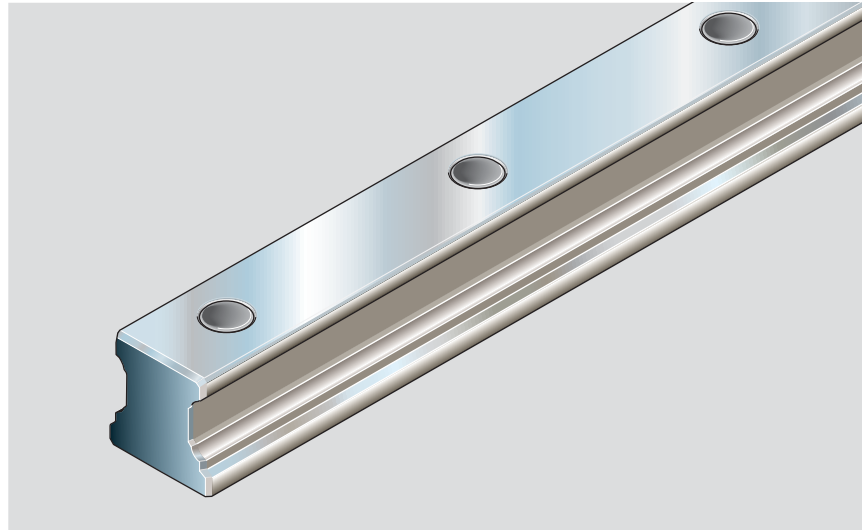

Part numbers and rail lengths

Size	Accuracy class	Guide rail		Spacing T (mm)	Recommended rail length Number of holes n_B / Rail length L (mm)
		one-part Part number, Rail length L (mm)	composite Part number, Number of sections Rail length L (mm)		
15	H	R1645 103 31,....	R1645 103 4,.....	60	From 2/ 116 to 40/ 2396 per formula $L = n_B \cdot T - 4$ Additional: 2/ 80 2/ 90 2/ 100
20	H	R1645 803 31,....	R1645 803 4,.....	60	From 2/ 116 to 55/ 3296 per formula $L = n_B \cdot T - 4$ Additional: 2/ 90 2/ 100
25	H	R1645 203 31,....	R1645 203 4,.....	60	From 2/ 116 to 64/ 3836 per formula $L = n_B \cdot T - 4$
30	H	R1645 703 31,....	R1645 703 4,.....	80	From 2/ 156 to 48/ 3836 per formula $L = n_B \cdot T - 4$
35	H	R1645 303 31,....	R1645 303 4,.....	80	From 2/ 156 to 48/ 3836 per formula $L = n_B \cdot T - 4$
45	H	R1645 403 31,....	R1645 403 4,.....	105	From 4/ 416 to 37/ 3881 per formula $L = n_B \cdot T - 4$
55	H	R1645 503 41,....	R1645 503 4,.....	120	From 6/ 716 to 32/ 3836 per formula $L = n_B \cdot T - 4$
65	H	R1645 603 41,....	R1645 603 4,.....	150	From 8/ 1196 to 25/ 3746 per formula $L = n_B \cdot T - 4$

Dimensions and masses

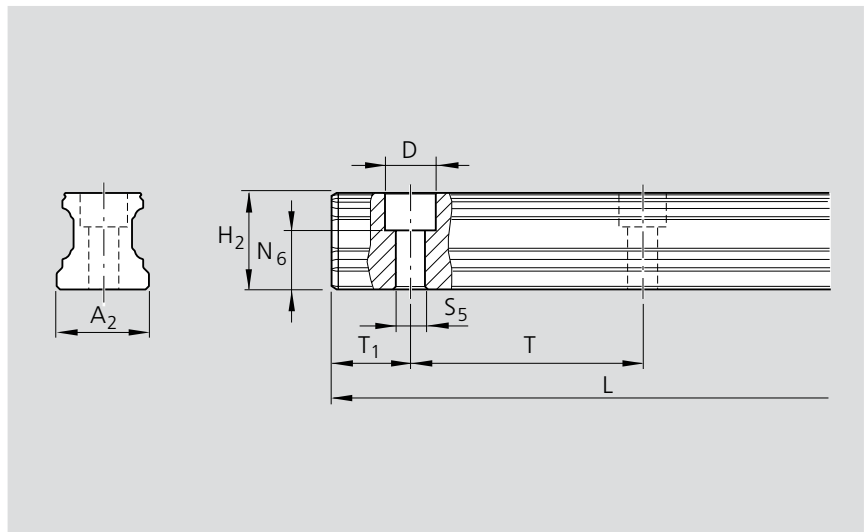

Size	Dimension (mm)									Mass (kg/m)
	A_2	H_2	$N_6^{\pm 0.5}$	D	S_5	$T_{15}^{+0.5/-1}$ ¹⁾	$T_{1\min}$	T	L_{\max}	
15	15	16.20	10.3	7.4	4.4	28.0	10	60	4000	1.4
20	20	20.55	13.2	9.4	6.0	28.0	10	60	4000	2.4
25	23	24.25	15.2	11.0	7.0	28.0	10	60	4000	3.2
30	28	28.35	17.0	15.0	9.0	38.0	12	80	4000	5.0
35	34	31.85	20.5	15.0	9.0	38.0	12	80	4000	6.8
45	45	39.85	23.5	20.0	14.0	50.5	16	105	4000	10.5
55	53	47.85	29.0	24.0	16.0	58.0	18	120	4000	16.2
65	63	59.85	38.5	26.0	18.0	73.0	20	150	4000	22.4

¹⁾ Preferred dimension

Recommended runner blocks

Recommended runner block:

Size 15 to 30:

- Runner blocks of accuracy class H to 10 μm clearance

Size 35 to 65:

- Runner blocks of accuracy class H to 0.02 C preload

Accuracy class H:

- Runner block optionally available as chromium-plated; part numbers available on request.

When using a combination of guide rails and runners block of different accuracy classes, the tolerances for dimensions H and A_3 change.

(Dimensions H and A_3 , see sections "Accuracy classes and their tolerances" at the technical data for runner blocks.) Exact values for the desired combinations are available on request.

Standard Guide Rails, Thin Dense Chrome Plated

Guide rail
Resist CR
R1647 .03 ..
Hard chromium-plated,
matt silver

For mounting from below

- The holes have a chrome coating.
- The end faces of composite rails are chromium-plated.

Versions:

- End faces not chromium-plated (except composite rails):
For part numbers, see table
- End faces chromium-plated:
Part numbers R1647 .3 41
- Composite guide rails are secured on both sides of the butt joint.

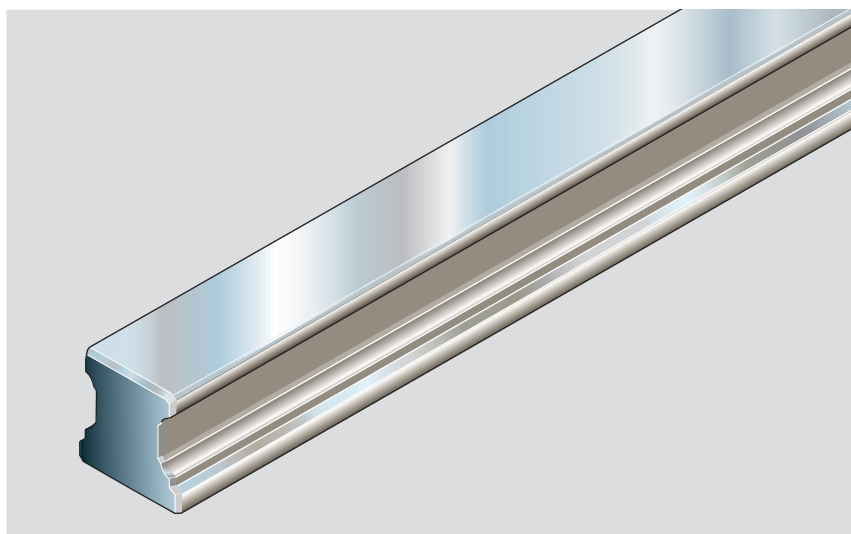

Part numbers and rail lengths

Size	Accuracy class	Guide rail		Spacing T (mm)	Recommended rail length Number of holes n _B / Rail length L (mm)
		one-part Part number, Rail length L (mm)	composite Part number, Number of sections Rail length L (mm)		
15	H	R1647 103 31,....	R1647 103 4,.....	60	From 2/ 116 to 40/ 2396 per formula L = nB · T - 4 Additional: 2/ 80 2/ 90 2/ 100
20	H	R1647 803 31,....	R1647 803 4,.....	60	From 2/ 116 to 55/ 3296 per formula L = nB · T - 4 Additional 2/ 90 2/ 100
25	H	R1647 203 31,....	R1647 203 4,.....	60	From 2/ 116 to 64/ 3836 per formula L = nB · T - 4
30	H	R1647 703 31,....	R1647 703 4,.....	80	From 2/ 156 to 48/ 3836 per formula L = nB · T - 4
35	H	R1647 303 31,....	R1647 303 4,.....	80	From 2/ 156 to 48/ 3836 per formula L = nB · T - 4
45	H	R1647 403 31,....	R1647 403 4,.....	105	From 4/ 416 to 37/ 3881 per formula L = nB · T - 4
55	H	R1647 503 41,....	R1647 503 4,.....	120	From 6/ 716 to 32/ 3836 per formula L = nB · T - 4
65	H	R1647 603 41,....	R1647 603 4,.....	150	From 8/ 1196 to 25/ 3746 per formula L = nB · T - 4

Dimensions and masses

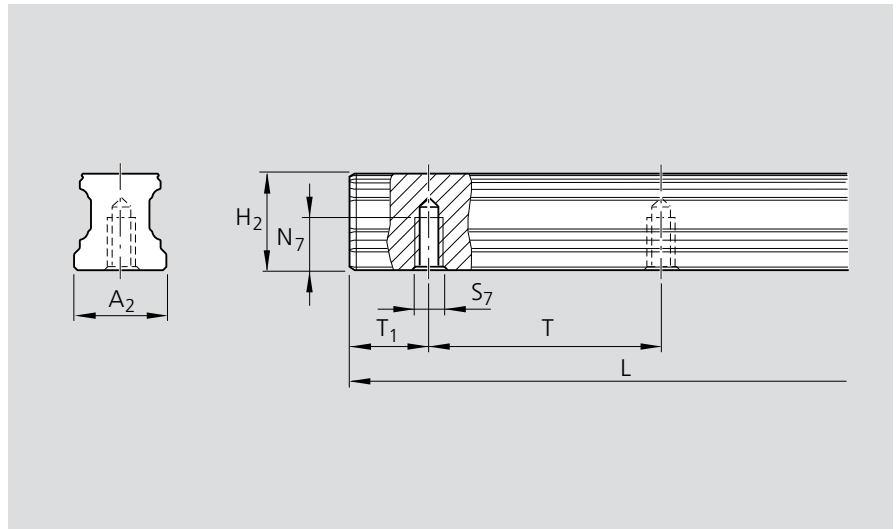

Size	Dimension (mm)								Mass (kg/m)
	A ₂	H ₂	N ₇	S ₇	T ₁₅₋₁ ^{+0.5¹⁾}	T _{1min}	T	L _{max}	
15	15	16.20	7.5	M5	28.0	10	60	4000	1.4
20	20	20.55	9.0	M6	28.0	10	60	4000	2.4
25	23	24.25	12.0	M6	28.0	10	60	4000	3.2
30	28	28.35	15.0	M8	38.0	12	80	4000	5.0
35	34	31.85	15.0	M8	38.0	12	80	4000	6.8
45	45	39.85	19.0	M12	50.5	16	105	4000	10.5
55	53	47.85	22.0	M14	58.0	18	120	4000	16.2
65	63	59.85	25.0	M16	73.0	20	150	4000	22.4

¹⁾ Preferred dimension

Recommended runner blocks

Recommended runner block:

Size 15 to 65:

- Runner blocks of accuracy class H to 10 µm clearance

Size 30 to 65:

- Runner blocks of accuracy class H to 0.02 C preload

Accuracy class H:

- Runner block optionally available as chromium-plated; part numbers available on request.

When using a combination of guide rails and runner blocks of different accuracy classes, the tolerances for dimensions H and A₃ change.

(Dimensions H and A₃, see sections "Accuracy classes and their tolerances" at the technical data for runner blocks.) Exact values for the desired combinations are available on request.

Product Overview Ball Rail Systems Resist NR II made of Corrosion-Resistant Steel

Ball rail systems Resist NR II made of corrosion-resistant steel* are used especially in conjunction with watery media, diluted acids, alkalis or salt solutions. These rail systems are extremely well suited for use at relative air humidity above 70% and temperatures above 30 °C.

Conditions like this are found above all in cleaning systems, galvanization and pickling systems, steam degreasing systems and also cooling machines.

As no additional corrosion protection is required, ball rail systems Resist NR II made of corrosion-resistant steel are very well suited for deployment in clean rooms and general printed circuit board production. Other possibilities for use are in the pharmaceuticals and food industries.

Excellent properties

- All metal parts are made of corrosion-resistant steel
- Available in 5 common sizes
- Excellent dynamic characteristics $v = 5 \text{ m/s}$; $a_{\text{max}} = 500 \text{ m/s}^2$
- Same load capacities in all 4 main load directions
- Available in accuracy classes N, H and P, up to preload class 0.08 C
- Long-term lubrication, up to several years possible
- Minimum quantity lubrication system with integrated reservoir for oil lubrication
- Lube ports with metal threads on all sides
- Unrestricted interchangeable design: can be combined with standard steel guide rails or standard and high-speed runner blocks made of steel or aluminum
- Optimum system rigidity through preloaded O-arrangement
- Existing range of accessories fully utilizable
- Runner block can be bolted from above or below
- Improved rigidity under lift-off and side loading conditions when additional mounting screws are used in holes provided at the center of the runner block
- Front face securing threads for all attachments
- High rigidity in all load directions – can therefore be used as an individual block
- Integral, all-round sealing
- Optimized entry-zone geometry reduces variation in elastic deflection
- Smooth and gentle running

Further Highlights

- Guide rails available with or without rail seal cover strip
- Guide rails available for mounting from above or below
- Runner blocks also available with chromium-plated guide rails

Optional

The same load capacities as standard runner blocks because of design with balls made of rolling bearing steel in conjunction with hard chromium-plated guide rail

* for roller bearing applications complying with DIN EN 10088

Material Specifications

- 1 Recirculation elements: POM
- 2 Lube nipple
- 3 Thread plates: 1.4303
- 4 Seals: TEE-E
- 5 Flange screws: 1.4303
- 6 Set screws: 1.4301
- 7 Balls: 1.4112
- 8 Housing: 1.4122
- 9 Strip holder: aluminum, black anodized
- 10 Clamping screw and nut: 1.4301
- 11 Guide rail: 1.4116
- 12 Rail seal cover strip: 1.4310

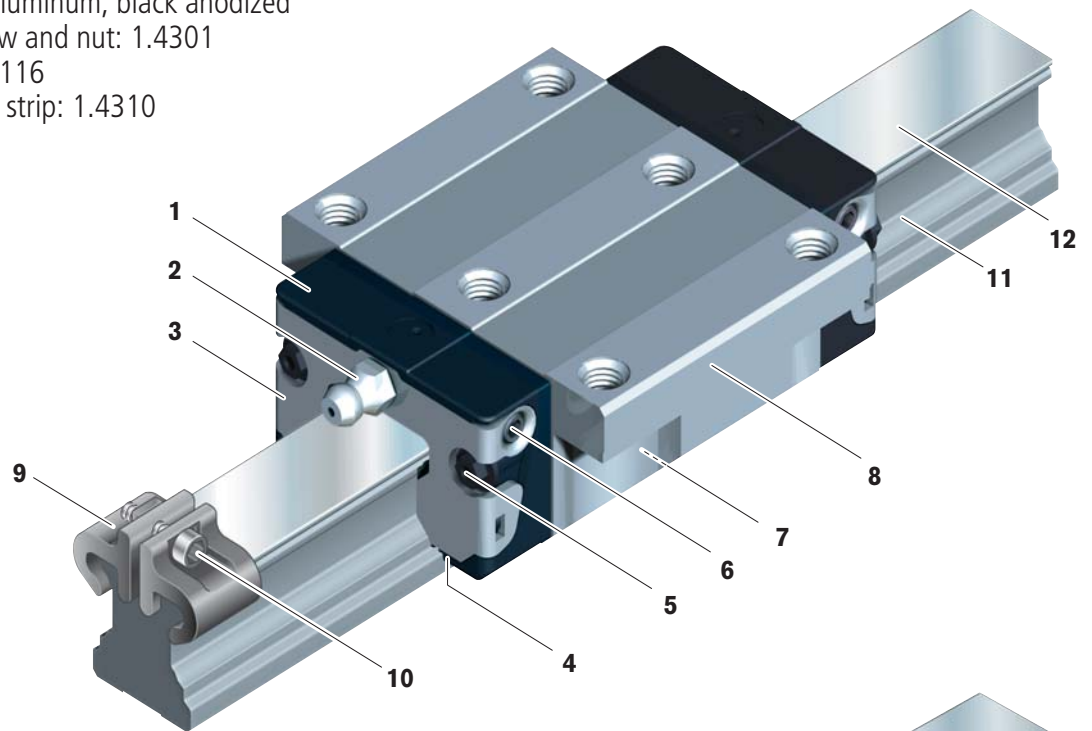

Proven rail seal cover strip for guide rail mounting holes

- One cover for all holes, saves time and costs
- Made of corrosion-resistant spring steel, DIN EN 10088
- Easy, secure mounting
- Clip on and fasten

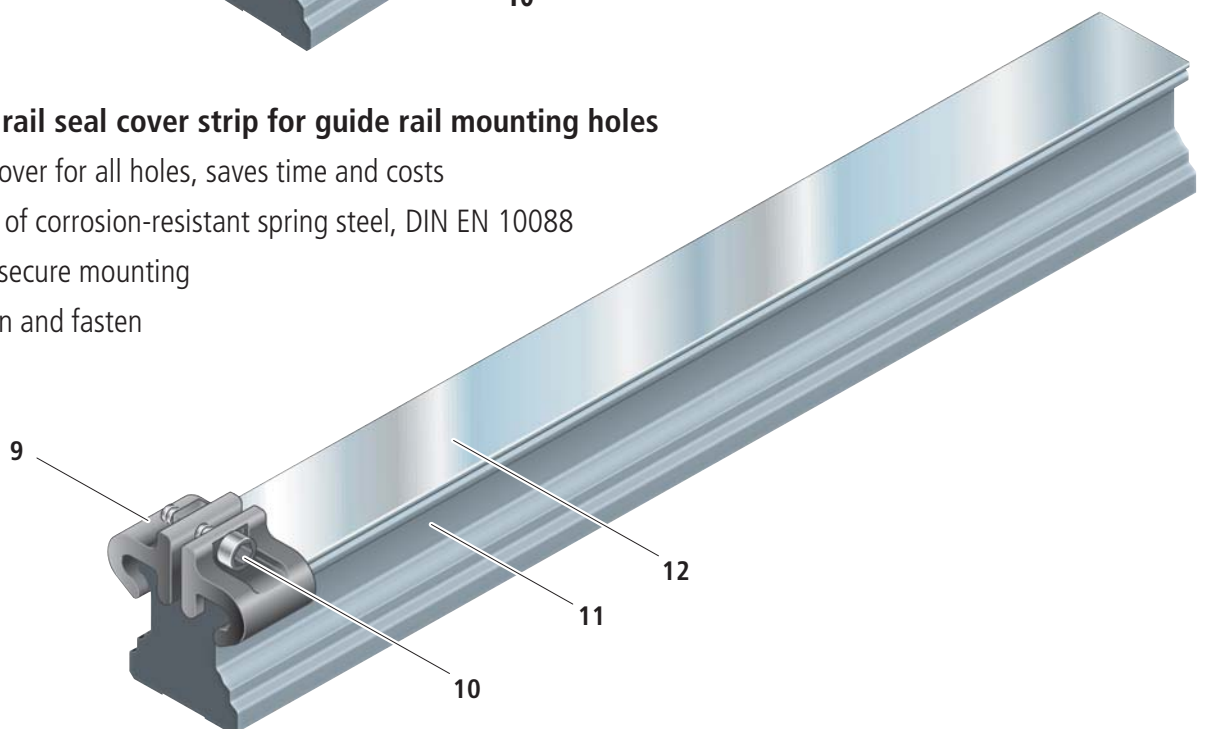

Resist NR II Runner Blocks Made of Corrosion-Resistant Steel*

Runner Block FNS R2001

Flange Standard With ball chain as an option

- Runner block without ball chain:
for part numbers, see table
- Runner block with low friction seal
without ball chain**:
Part numbers R2001 xxx 05
- Runner block with ball chain:
Part numbers R2001 xxx 06
- Runner block with low friction seal
with ball chain**:
Part numbers R2001 xxx 07

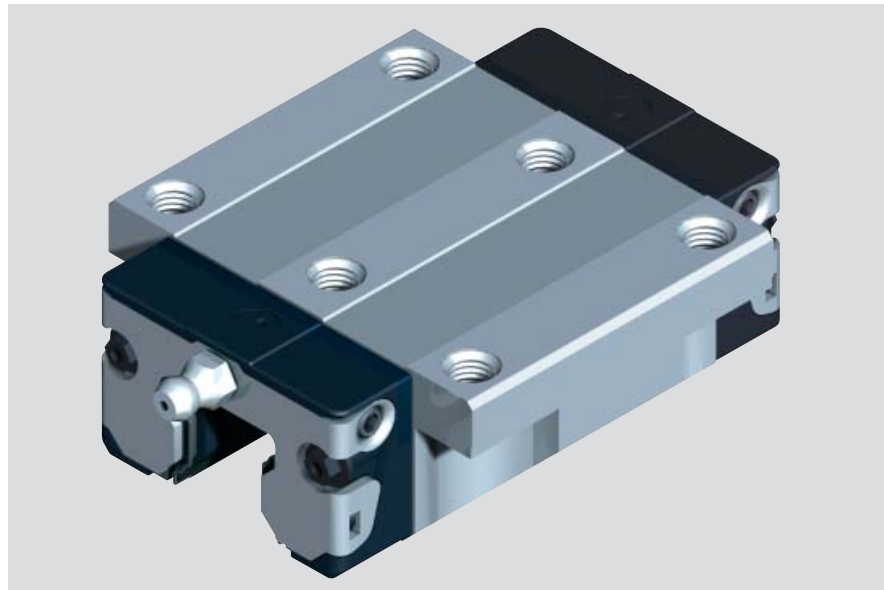

Dynamic characteristics

Speed $v_{max} = 5 \text{ m/s}$
 Acceleration $a_{max} = 500 \text{ m/s}^2$

Precision Runner Blocks

- No preservative oil
- Not pre-lubricated

Size	Accuracy Class	Part numbers for runner blocks for preload class		
		C0	C1	C2
15	N	R2001 194 04	R2001 114 04	R2001 124 04
	H	R2001 193 04	R2001 113 04	R2001 123 04
	P		R2001 112 04	R2001 122 04
20	N	R2001 894 04	R2001 814 04	R2001 824 04
	H	R2001 893 04	R2001 813 04	R2001 823 04
	P		R2001 812 04	R2001 822 04
25	N	R2001 294 04	R2001 214 04	R2001 224 04
	H	R2001 293 04	R2001 213 04	R2001 223 04
	P		R2001 212 04	R2001 222 04
30	N	R2001 794 04	R2001 714 04	R2001 724 04
	H	R2001 793 04	R2001 713 04	R2001 723 04
	P		R2001 712 04	R2001 722 04
35	N	R2001 394 04	R2001 314 04	R2001 324 04
	H	R2001 393 04	R2001 313 04	R2001 323 04
	P		R2001 312 04	R2001 322 04

**Low friction seal available for preloads C1 and C0 (only in accuracy classes N, H)

Preload Class

- C0 = without Preload
- C1 = Preload 2% C
- C2 = Preload 8% C

For further technical information, please see chapter on "General Technical Data and Calculations".

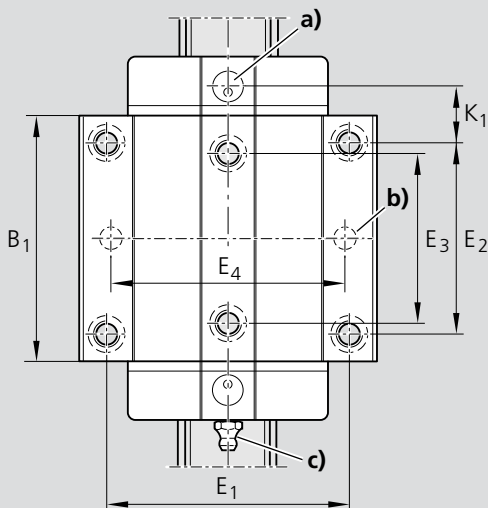
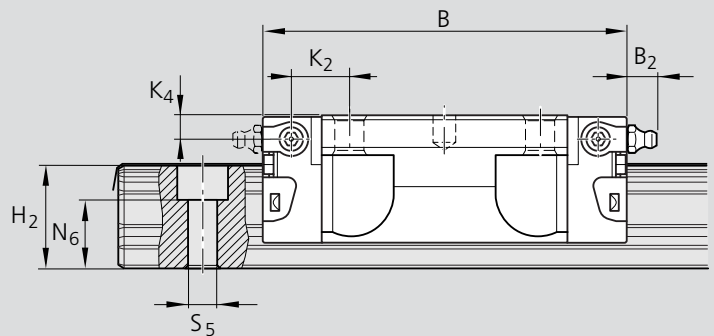
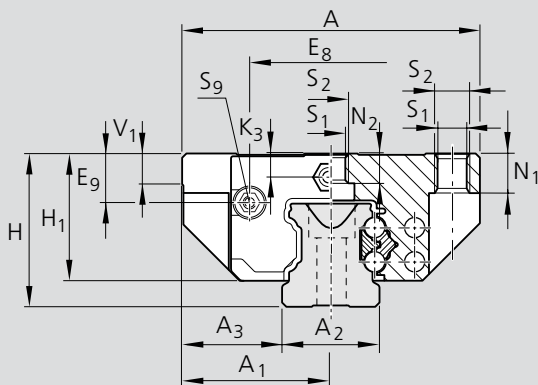

- a) For O-ring
Size 15: dia. 4 · 1.0 (mm)
Size 20-35: dia. 5 · 1.0 (mm)
Open lube bore as required.
See Accessories:
Mounting lubrication adapter.
- b) Recommended position for pin holes (dimensions E₄ see "Mounting Instructions", Section "Locating pins" in main catalog 82 201).
Note
Ready-drilled holes made for production purposes may already exist at this position. These may be extended and bored open to accommodate the locating pins.
- c) Lube nipple sizes 15 and 20: funnel-type nipple
Type A – M3 x 5, DIN 3405
B₂ = 1.6 mm
If another lube nipple is used: observe the screw-in depth of 5 mm!
Size 25 to 35: M6 x 8, DIN 71412
B₂ = 9.5 mm
If another lube nipple is used: observe the screw-in depth of 8 mm!
Connection possible at all sides.

Dimensions (mm)

Size	A	A ₁	A ₂	A ₃	B	B ₁	H	H ₁	H ₂ ¹⁾	H ₂ ²⁾	V ₁	E ₁	E ₂	E ₃	E ₈	E ₉	K ₁	K ₂	K ₃	K ₄
15	47	23.5	15	16.0	58.2	39.2	24	19.90	16.30	16.20	5.0	38	30	26	24.55	6.70	8.00	9.6	3.20	3.20
20	63	31.5	20	21.5	75.0	49.6	30	25.35	20.75	20.55	6.0	53	40	35	32.50	7.30	11.80	11.8	3.35	3.35
25	70	35.0	23	23.5	86.2	57.8	36	29.90	24.45	24.25	7.5	57	45	40	38.30	11.50	12.45	13.6	5.50	5.50
30	90	45.0	28	31.0	97.7	67.4	42	35.35	28.55	28.35	7.0	72	52	44	48.40	14.60	14.00	15.7	6.05	6.05
35	100	50.0	34	33.0	110.5	77.0	48	40.40	32.15	31.85	8.0	82	62	52	8.00	17.35	14.50	16.0	6.90	6.90

¹⁾ Dimension H₂ with rail seal cover strip

²⁾ Dimension H₂ without rail seal cover strip

Size	Dimensions (mm)								Mass (kg)	Load capacities (N) ³⁾				Moments (Nm)			
	N ₁	N ₂	N ₆ ±0.5	S ₁	S ₂	S ₅	S ₉	C dyn.		C ₀ stat.	M _t dyn.	M _{t0} stat.	M _L dyn.	M _{L0} stat.			
15	5.2	4.4	10.30	4.3	M5	4.4	M2.5-3.5 deep	0.20	5 100	9 300	63	90	34	49			
20	7.7	5.2	13.20	5.3	M6	6.0	M3-5 deep	0.45	12 300	16 900	205	215	110	115			
25	9.3	7.0	15.20	6.7	M8	7.0	M3-5 deep	0.65	15 000	21 000	270	295	150	165			
30	11.0	7.9	17.00	8.5	M10	9.0	M3-5 deep	1.10	20 800	28 700	460	500	245	265			
35	12.0	10.2	20.50	8.5	M10	9.0	M3-5 deep	1.60	27 600	37 500	760	805	375	390			

³⁾ Load capacities for version without ball chain. Load capacities for version without ball chain, see Product Overview with Load Capacities. Determination of the dynamic of the load capacities and moments is based on 100 000 m of stroke travel, however, only 50,000 m are often actually stipulated. Comparison: Value C, M_t and M_L per table multiplied by 1.26.

Resist NR II Runner Blocks Made of Corrosion-Resistant Steel

Runner Block SNS R2011

Slimline Standard With ball chain as an option

- Runner block without ball chain:
for part numbers, see table
- Runner block with low friction seal
without ball chain^{**}:
Part numbers R2011 xxx 05
- Runner block with ball chain:
Part numbers R2011 xxx 06
- Runner block with low friction seal
with ball chain^{**}:
Part numbers R2011 xxx 07

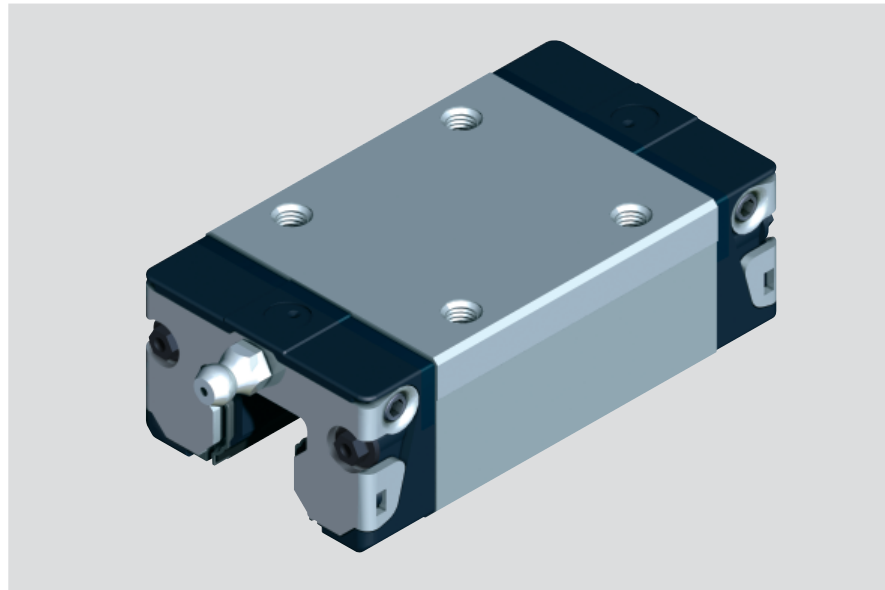

Dynamic characteristics

Speed $v_{max} = 5 \text{ m/s}$
 Acceleration $a_{max} = 500 \text{ m/s}^2$

Precision Runner Blocks

- No preservative oil
- Not pre-lubricated

Size	Accuracy Class	Part numbers for runner blocks for preload class		
		C0	C1	C2
15	N	R2011 194 04	R2011 114 04	R2011 124 04
	H	R2011 193 04	R2011 113 04	R2011 123 04
	P		R2011 112 04	R2011 122 04
20	N	R2011 894 04	R2011 814 04	R2011 824 04
	H	R2011 893 04	R2011 813 04	R2011 823 04
	P		R2011 812 04	R2011 822 04
25	N	R2011 294 04	R2011 214 04	R2011 224 04
	H	R2011 293 04	R2011 213 04	R2011 223 04
	P		R2011 212 04	R2011 222 04
30	N	R2011 794 04	R2011 714 04	R2011 724 04
	H	R2011 793 04	R2011 713 04	R2011 723 04
	P		R2011 712 04	R2011 722 04
35	N	R2011 394 04	R2011 314 04	R2011 324 04
	H	R2011 393 04	R2011 313 04	R2011 323 04
	P		R2011 312 04	R2011 322 04

^{**}Delivery available for low friction seal and preload C1 and C0 (only in accuracy classes N, H)

Preload Class

C0 = without Preload
 C1 = Preload 2% C
 C2 = Preload 8% C

For further technical information, please see chapter on "General Technical Data and Calculations".

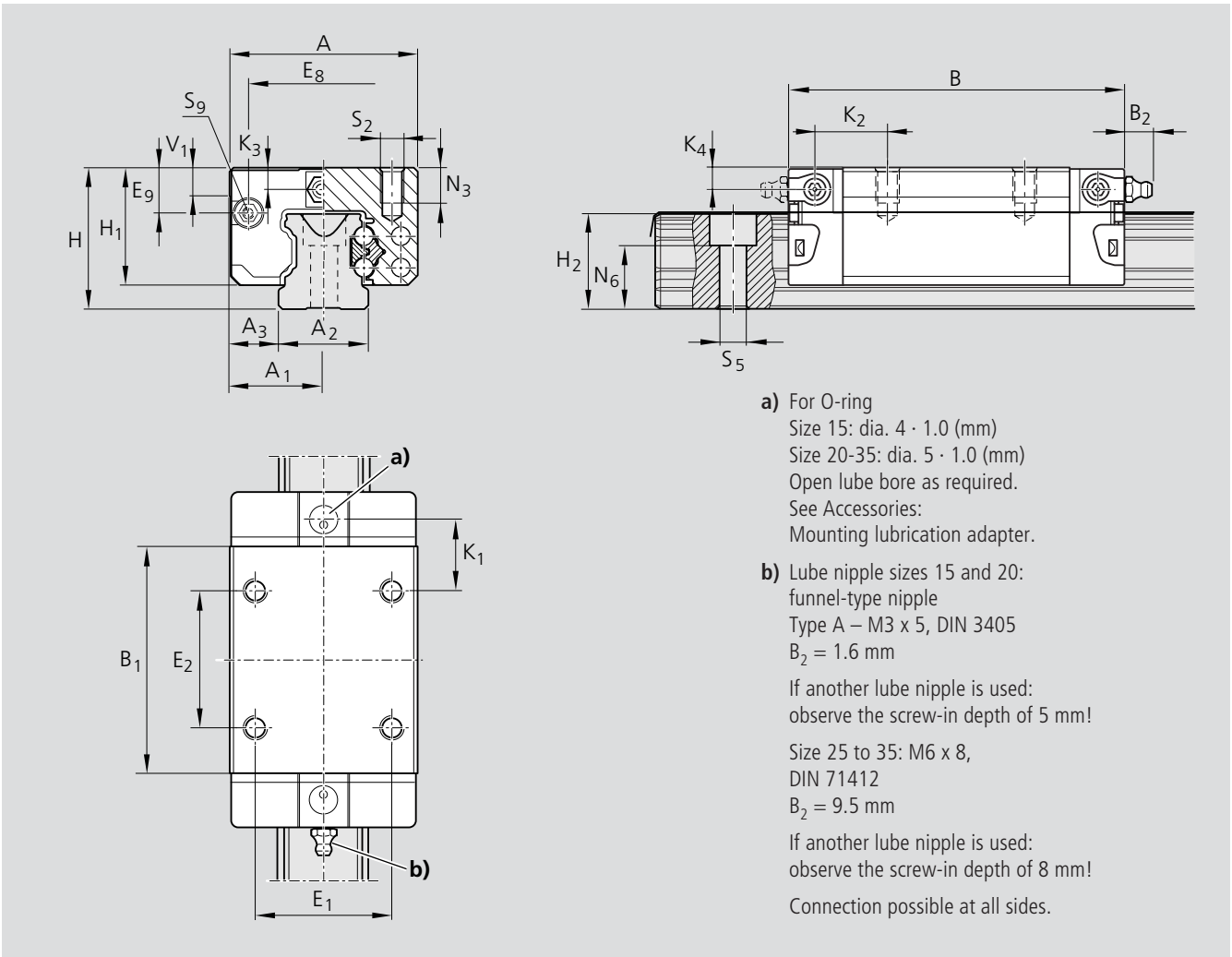

Dimensions (mm)																			
Size	A	A ₁	A ₂	A ₃	B	B ₁	H	H ₁	H ₂ ¹⁾	H ₂ ²⁾	V ₁	E ₁	E ₂	E ₈	E ₉	K ₁	K ₂	K ₃	K ₄
15	34	17	15	9.5	58.2	39.2	24	19.90	16.30	16.20	5.0	26	26	24.55	6.70	10.00	11.60	3.20	3.20
20	44	22	20	12.0	75.0	49.6	30	25.35	20.75	20.55	6.0	32	36	32.50	7.30	13.80	13.80	3.35	3.35
25	48	24	23	12.5	85.2	57.8	36	29.90	24.45	24.25	7.5	35	35	38.30	11.50	17.45	18.60	5.50	5.50
30	60	30	28	16.0	97.7	67.4	42	35.35	28.55	28.35	7.0	40	40	48.40	14.60	20.00	21.70	6.05	6.05
35	70	35	34	18.0	110.5	77.0	48	40.40	32.15	31.85	8.0	50	50	58.00	17.35	20.50	22.00	6.90	6.90

¹⁾ Dimension H₂ with rail seal cover strip

²⁾ Dimension H₂ without rail seal cover strip

Size	Dimensions (mm)					Mass (kg)	Load capacities (N) ³⁾		Moments (Nm)			
	N ₃	N ₆ ^{±0.5}	S ₂	S ₅	S ₉		C dyn.	C ₀ stat.	M _t dyn.	M _{t0} stat.	M _L dyn.	M _{L0} stat.
15	6.0	10.30	M4	4.4	M2.5-3.5 deep	0.15	5 100	9 300	63	90	34	49
20	7.5	13.20	M5	6.0	M3-5 deep	0.35	12 300	16 900	205	215	110	115
25	9.0	15.20	M6	7.0	M3-5 deep	0.50	15 000	21 000	270	295	150	165
30	12.0	17.00	M8	9.0	M3-5 deep	0.85	20 800	28 700	460	500	245	265
35	13.0	20.50	M8	9.0	M3-5 deep	1.25	27 600	37 500	760	305	375	390

³⁾ Load capacities for version without ball chain. Load capacities for version without ball chain, see Product Overview with Load Capacities. Determination of the dynamic of the load capacities and moments is based on 100 000 m of stroke travel, however, only 50,000 m are often actually stipulated. Comparison: Value C, M_t and M_L per table multiplied by 1.26.

Guide Rails Resist NR II¹⁾

Guide Rail R2045 .3. ...

For mounting from above, with rail seal and strip holder

Note

The guide rails are also available as composite rails.

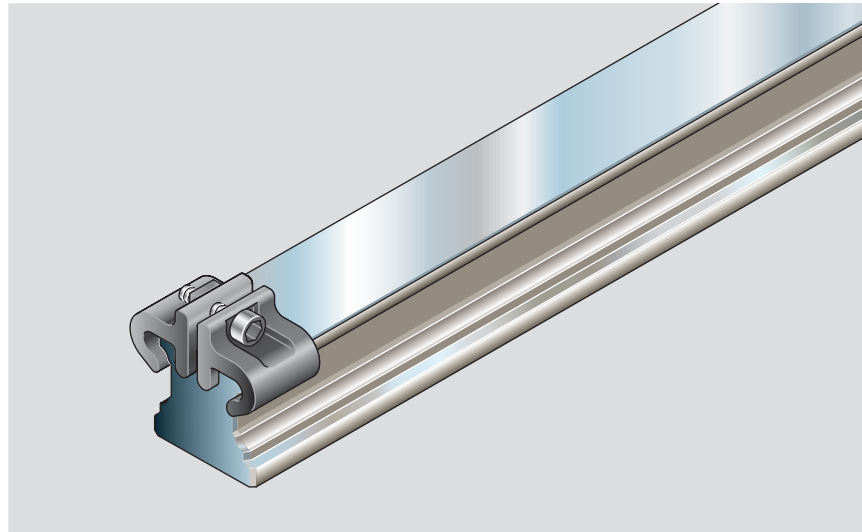

Part numbers and rail lengths

Size	Accuracy class	Guide rail		Spacing T (mm)	Recommended rail length Number of holes n _B / Rail length L (mm)
		one-part Part number, Rail length L (mm)	composite Part number, Number of sections Rail length L (mm)		
15 ²⁾	N	R2045 134 31,....	R2045 134 3,....	60	From: 2/ 116 to 40/ 2396 per formula L = n_B · T - 4 Additional: 2/ 84 2/ 90 2/ 100
	H	R2045 133 31,....	R2045 133 3,....		
	P	R2045 132 31,....	R2045 132 3,....		
20 ²⁾	N	R2045 834 31,....	R2045 834 3,....	60	From: 2/ 116 bis 55/ 3296 per formula L = n_B · T - 4 Additional: 2/ 90 2/ 100
	H	R2045 833 31,....	R2045 833 3,....		
	P	R2045 832 31,....	R2045 832 3,....		
25	N	R2045 234 31,....	R2045 234 3,....	60	From: 2/ 116 to 64/ 3836 per formula L = n_B · T - 4
	H	R2045 233 31,....	R2045 233 3,....		
	P	R2045 232 31,....	R2045 232 3,....		
30	N	R2045 734 31,....	R2045 734 3,....	80	From: 2/ 156 to 48/ 3836 per formula L = n_B · T - 4
	H	R2045 733 31,....	R2045 733 3,....		
	P	R2045 732 31,....	R2045 732 3,....		
35	N	R2045 334 61,....	R2045 334 6,....	80	From: 2/ 156 to 48/ 3836 per formula L = n_B · T - 4
	H	R2045 333 61,....	R2045 333 6,....		
	P	R2045 332 61,....	R2045 332 6,....		

1) Made from corrosion-resistant steel for roller bearing applications per DIN EN 10088

2) In Preparation

For ordering examples, see Standard Rail Guides

Dimensions and masses

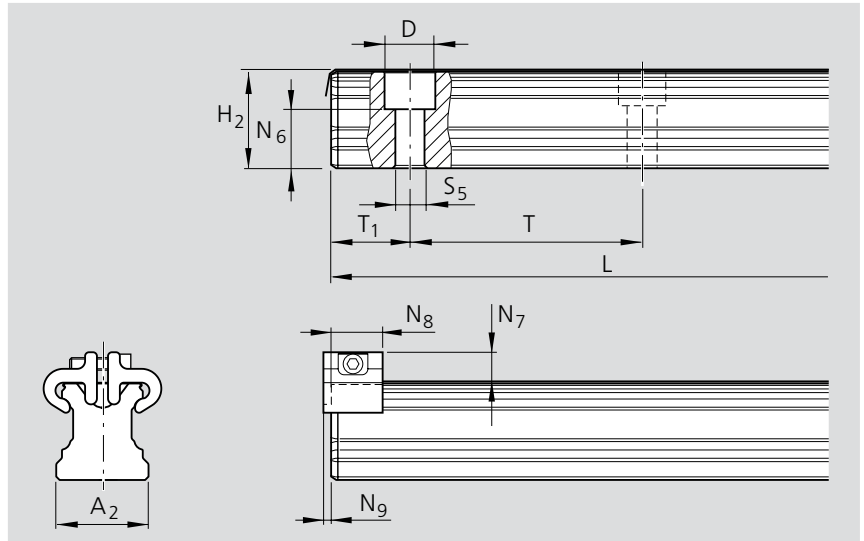

Size	Dimensions (mm)												Mass (kg/m)
	A ₂	H ₂ ¹⁾	N ₆ ^{±0.5}	N ₇ ²⁾	N ₈	N ₉	D	S ₅	T ₁₅ ^{+0.5³⁾-1}	T _{1 min}	T	L _{max}	
15	15	16.30	10.3	7.3	12	2.0	7.4	4.4	28.0	12	60	4000	1.4
20	20	20.75	13.2	7.1	12	2.0	9.4	6.0	28.0	13	60	4000	2.4
25	23	24.45	15.2	8.2	13	2.0	11.0	7.0	28.0	13	60	4000	3.2
30	28	28.55	17.0	8.7	13	2.0	15.0	9.0	38.0	16	80	4000	5.0
35	34	32.15	20.5	11.7	16	2.2	15.0	9.0	38.0	16	80	4000	6.8

¹⁾ Dimension H₂ with rail seal cover strip

²⁾ Dimension N₇ with rail seal cover strip

³⁾ Preferred dimension

Standard Guide Rails Resist NR II¹⁾

Guide rails R2045 .0. ..

For mounting from above,
with plastic mounting hole plugs
(supplied)

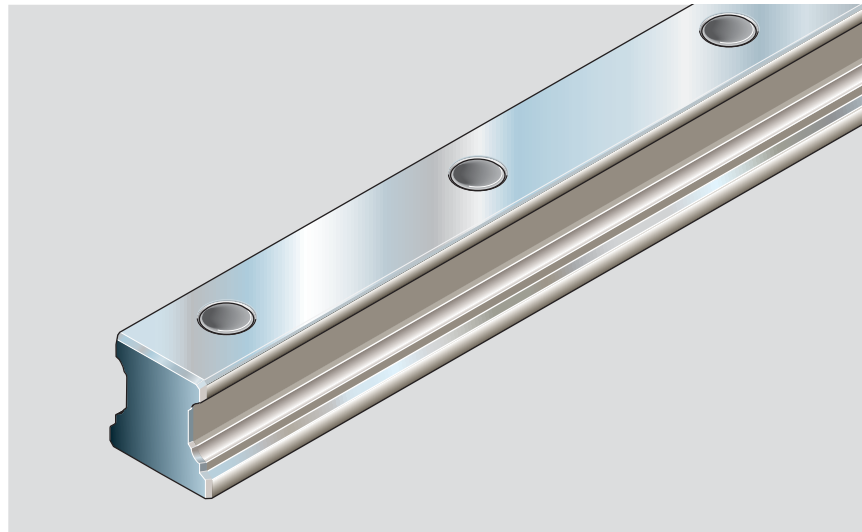

Part numbers and rail lengths

Size	Accuracy class	Guide rail		Spacing T (mm)	Recommended rail length Number of holes n _B / Rail length L (mm)
		one-part Part number, Rail length L (mm)	composite Part number, Number of sections Rail length L (mm)		
15 ²⁾	N	R2045 104 31,.....	R2045 104 3,.....	60	From 2/ 116 to 40/ 2396 per formula L = nB · T - 4 Additional: 2/ 80 2/ 90 2/ 100
	H	R2045 103 31,.....	R2045 103 3,.....		
	P	R2045 102 31,.....	R2045 102 3,.....		
20 ²⁾	N	R2045 804 31,.....	R2045 804 3,.....	60	From 2/ 116 to 55/ 3296 per formula L = nB · T - 4 Additional: 2/ 90 2/ 100
	H	R2045 803 31,.....	R2045 803 3,.....		
	P	R2045 802 31,.....	R2045 802 3,.....		
25	N	R2045 204 31,.....	R2045 204 3,.....	60	From 2/ 116 to 64/ 3836 per formula L = nB · T - 4
	H	R2045 203 31,.....	R2045 203 3,.....		
	P	R2045 202 31,.....	R2045 202 3,.....		
30	N	R2045 704 31,.....	R2045 704 3,.....	80	From 2/ 156 to 48/ 3836 per formula L = nB · T - 4
	H	R2045 703 31,.....	R2045 703 3,.....		
	P	R2045 702 31,.....	R2045 702 3,.....		
35	N	R2045 304 31,.....	R2045 304 3,.....	80	From 2/ 156 to 48/ 3836 per formula L = nB · T - 4
	H	R2045 303 31,.....	R2045 303 3,.....		
	P	R2045 302 31,.....	R2045 302 3,.....		

1) Made from corrosion-resistant steel for roller bearing applications per DIN EN 10088

2) In Preparation

For ordering examples, see Standard Rail Guides

Dimensions and masses

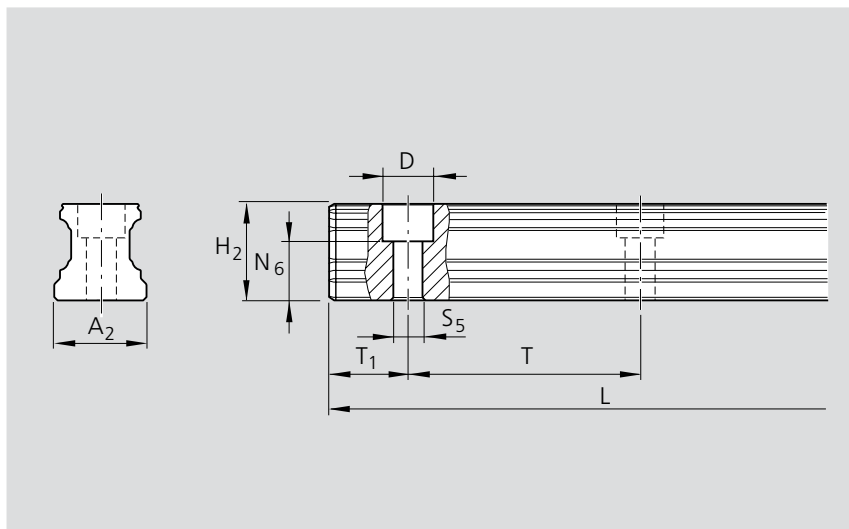

Size	Dimension (mm)									Mass (kg/m)
	A_2	$H_2^{1)}$	$N_6^{\pm 0.5}$	D	S_5	$T_{15}^{+0.5^{2)}$	$T_{1 \text{ min}}$	T	L_{max}	
15	15	16.20	10.3	7.4	4.4	28.0	12	60	4000	1.4
20	20	20.55	13.2	9.4	6.0	28.0	13	60	4000	2.4
25	23	24.25	15.2	11.0	7.0	28.0	13	60	4000	3.2
30	28	28.35	17.0	15.0	9.0	38.0	16	80	4000	5.0
35	34	31.85	20.5	15.0	9.0	38.0	16	80	4000	6.8

¹⁾ Dimension H_2 without rail seal cover strip

²⁾ Preferred dimension

Standard Guide Rails Made of Corrosion-Resistant Steel

Guide Rail 2047-
For mounting from below

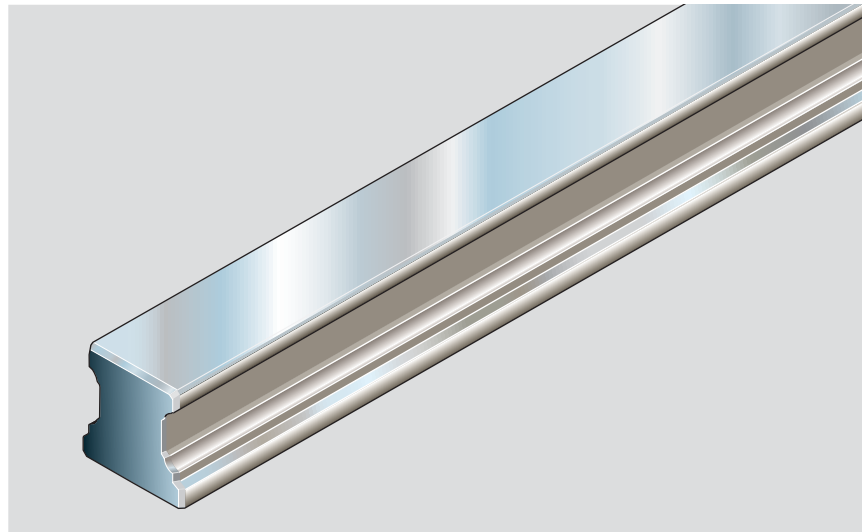

Part numbers and rail lengths

Size	Accuracy class	Guide rail		Spacing T (mm)	Recommended rail length Number of holes n _B / Rail length L (mm)
		one-part Part number, Rail length L (mm)	composite Part number, Number of sections Rail length L (mm)		
15 ²⁾	N	R2047 104 31,.....	R2047 104 3,.....	60	From 2/ 116 to 40/ 2396 per formula L = nB · T - 4 Additional: 2/ 80 2/ 90 2/ 100
	H	R2047 103 31,.....	R2047 103 3,.....		
	P	R2047 102 31,.....	R2047 102 3,.....		
20 ²⁾	N	R2047 804 31,.....	R2047 804 3,.....	60	From 2/ 116 to 55/ 3296 per formula L = nB · T - 4 Additional: 2/ 90 2/ 100
	H	R2047 803 31,.....	R2047 803 3,.....		
	P	R2047 802 31,.....	R2047 802 3,.....		
25	N	R2047 204 31,.....	R2047 204 3,.....	60	From 2/ 116 to 64/ 3836 per formula L = nB · T - 4
	H	R2047 203 31,.....	R2047 203 3,.....		
	P	R2047 202 31,.....	R2047 202 3,.....		
30	N	R2047 704 31,.....	R2047 704 3,.....	80	From 2/ 156 to 48/ 3836 per formula L = nB · T - 4
	H	R2047 703 31,.....	R2047 703 3,.....		
	P	R2047 702 31,.....	R2047 702 3,.....		
35	N	R2047 304 31,.....	R2047 304 3,.....	80	From 2/ 156 to 48/ 3836 per formula L = nB · T - 4
	H	R2047 303 31,.....	R2047 303 3,.....		
	P	R2047 302 31,.....	R2047 302 3,.....		

1) Made from corrosion-resistant steel for roller bearing applications per DIN EN 10088

2) In Preparation

For ordering examples, see Standard Rail Guides

Dimensions and masses

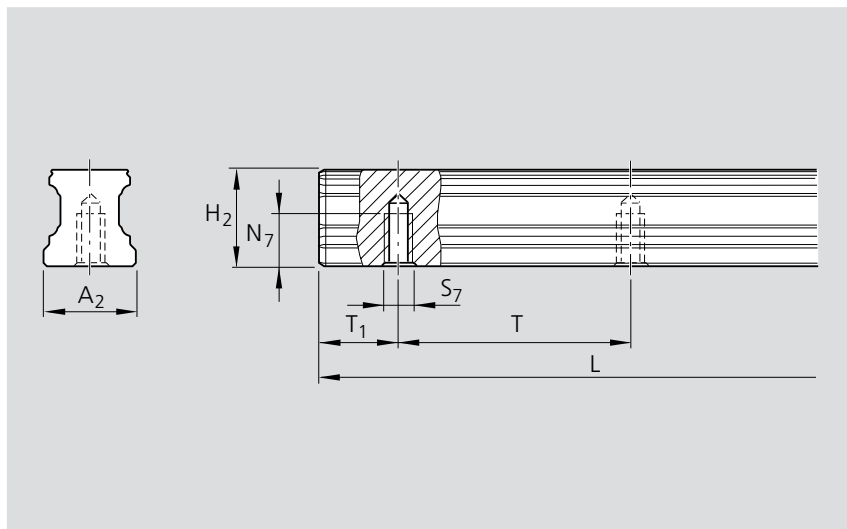

Size	Dimension (mm)								Mass (kg/m)
	A_2	H_2	N_7	S_7	$T_{15}^{+0.5^1}$	T_{1min}	T	L_{max}	
15	15	16.20	7.5	M5	28.0	10	60	4000	1.4
20	20	20.55	9.0	M6	28.0	10	60	4000	2.4
25	23	24.25	12.0	M6	28.0	10	60	4000	3.2
30	28	28.35	15.0	M8	38.0	12	80	4000	5.0
35	34	31.85	15.0	M8	38.0	12	80	4000	6.8

¹⁾ Preferred dimension

Accessories for Standard Runner Blocks

Rexroth offers suitable accessories for virtually all special requirements. The complete program at one stop. Perfectly geared for excellent performance.

Two-piece front seal

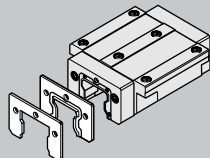

Scraper Plates

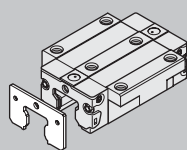

Lubrication plate

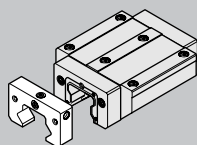

Viton scraper plates

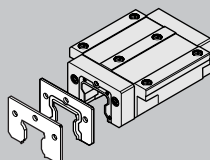

Protective bellows

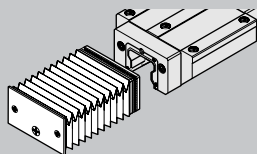

Lubrication Adapter (only for runner blocks SNH, SLH)

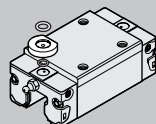

Front lube unit

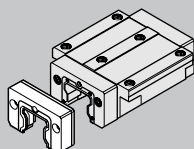

suitable for

Mounting Accessories

For Mounting accessories, see Mounting Instructions for Ball Rail Systems RE 82 270

Standard Runner Blocks

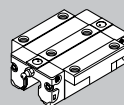

Runner Block
Flange Standard FNS
R1651
R2001
R1631

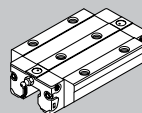

Runner Block
Flange long FLS
R1653
R2002

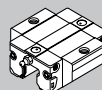

Runner Block
Flange short FKS
R1665
 **R1661**

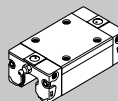

Runner Block
Slimline Standard SNS
R1622
R2011
R1632

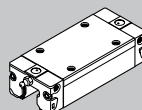

Runner Block
Slimline Long SLS
R1623
R2012

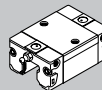

Runner Block
Slimline Short SKS
R1666
 **R1662**

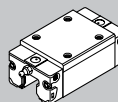

Runner Block
Slimline High SNH
R1621

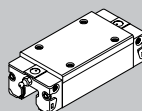

Runner Block
Slimline Long High SLH
R1624

Accessories for Standard Runner Blocks

Two-piece front seal

Note:

The mounting screws are supplied.

Observe minimum screw-in depth for front lube connector.

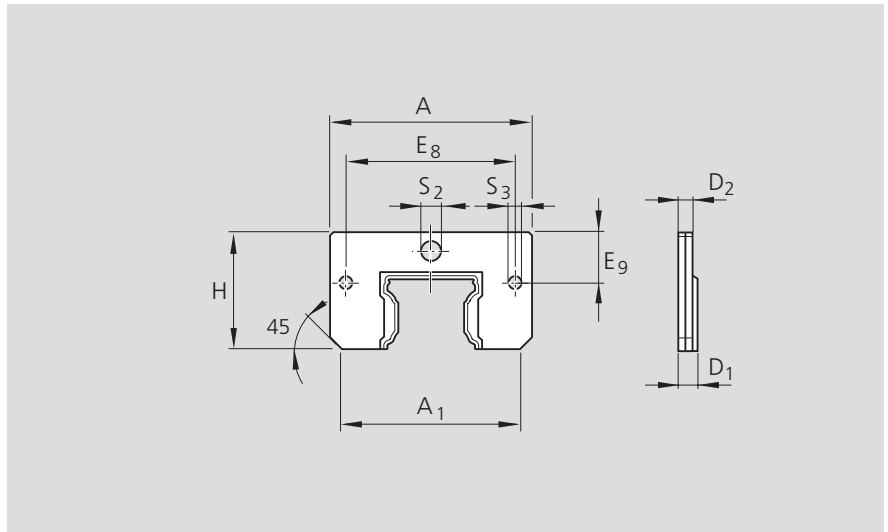

Size	Part numbers	Dimensions (mm)										Mass (g)
		A	A ₁	H	E ₈	E ₉	S ₂	S ₃	D ₁	D ₂		
15	R1619 121 20	32	27	19.0	24.55	6.3	∅4.3	∅3.5	3.0	2.2	6	
20	R1619 821 20	42	39	24.3	32.4	6.8	∅5.1	∅4	3.3	2.5	8	
25	R1619 221 30	47	42	29.0	38.3	11.0	∅7	∅4	3.3	2.5	10	
30	R1619 721 30	59	53	34.5	48.4	14.1	∅7	∅4	4.5	3.3	18	
35	R1619 321 30	69	61	39.5	58.0	17.0	∅7	∅4	4.5	3.3	25	
45	R1619 421 30	85	77	49.5	69.8	20.5	∅7	∅5	5.5	4.0	55	
55	R1619 521 30	98	90	56.0	80.0	21.5	∅7	∅6	5.5	4.0	65	

Set of seals

The set of seals consists of the following components:

- 1 Scraper plate
- 2 Supporting plate
- 3 Two-piece front seal

Note:

For end lubrication, observe minimum screw-in depth.

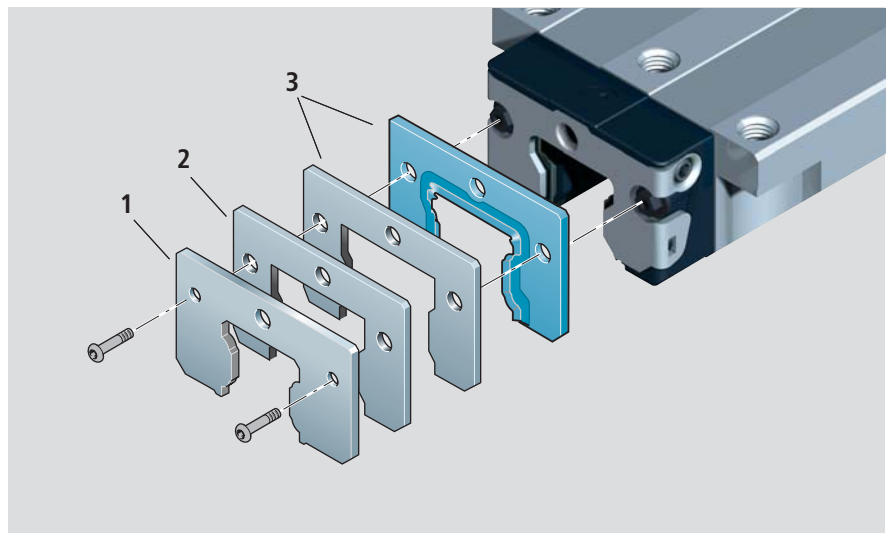

Size	Part numbers. set of seals	
	For guide rail Without rail seal cover strip	For guide rail With rail seal cover strip
15	R1619 120 50	R1619 120 50
20	R1619 820 50	R1619 120 50
25	R1619 220 50	R1619 120 50
30	R1619 720 50	R1619 120 50
35	R1619 320 40	R1619 320 50
45	R1619 420 40	R1619 420 50
55	R1619 520 40	R1619 520 50

Accessories for Standard Runner Blocks

Scraper plate

- Material: corrosion-resistant spring steel complying with DIN EN 10088
- Finish: bright
- Precision version with 0.2 to 0.3 mm maximum gap dimension

Mounting:

The mounting screws are supplied with the scraper plate.

When mounting, ensure that there is a uniform gap between runner block and scraper plate.

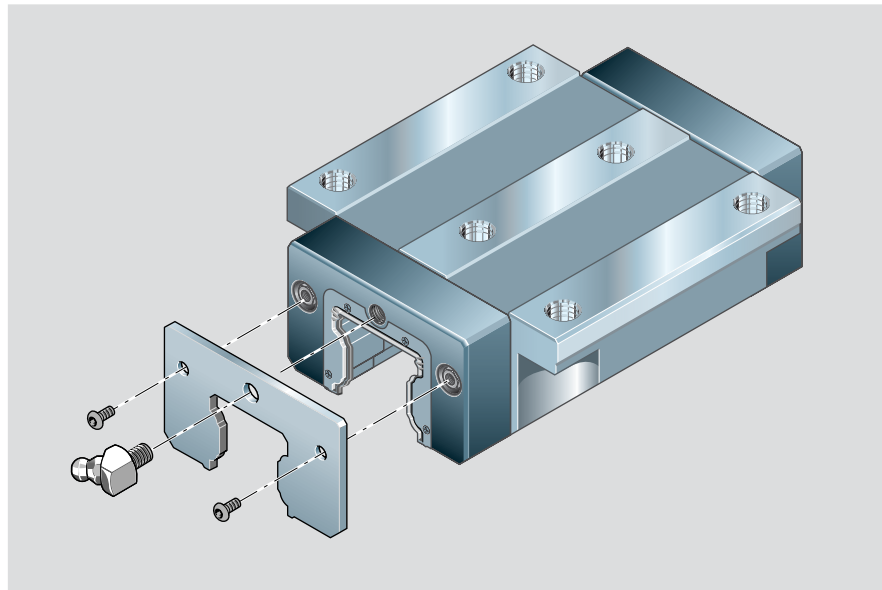

Scraper plates for guide rails with and without rail seal cover strips

Note:

When used with two-piece front seal, use set of seals R1619 .20 40/50.

Note:

For end side lubrication, observe minimum screw-in depth.

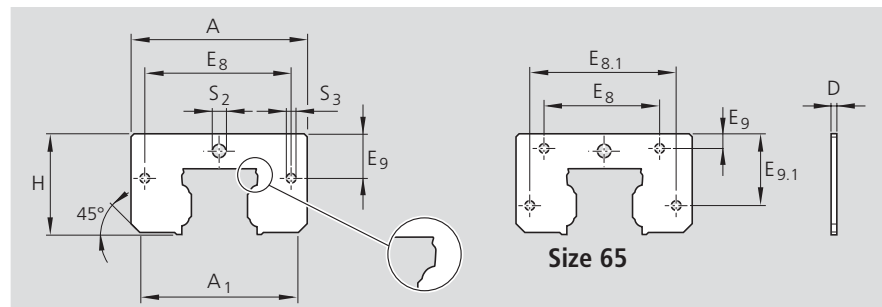

Size	Part numbers	Dimensions (mm)										Mass (g)
		A	A ₁	H	E ₈	E _{8.1}	E ₉	E _{9.1}	S ₂	S ₃	D	
15	R1620 110 30	33	26.4	19.2	24.55	–	6.3	–	∅4.6	∅3.5	1.0	5
20	R1620 810 30	42	40.0	24.8	32.4	–	6.8	–	∅5.1	∅4	1.0	6
25	R1620 210 30	47	41.6	29.5	38.3	–	11.0	–	∅7	∅4	1.0	8
30	R1620 710 30	59	52.8	34.7	48.4	–	14.1	–	∅7	∅4	1.0	12
35*	R1620 310 40	69	60.9	40.1	58.0	–	17.0	–	∅7	∅4	1.0	16
45*	R1620 410 40	85	76.7	50.0	69.8	–	20.5	–	∅7	∅5	2.0	50
55*	R1620 510 40	98	89.8	56.4	80.0	–	21.8	–	∅7	∅6	2.0	65
65*	R1620 610 40	124	113.2	74.7	76.0	100	10.0	52.5	∅9	∅5	2.5	140
20	R1620 810 35	41	38.0	22.8	30.5	–	5.1	–	∅4	∅4	1.0	5
25	R1620 210 35	47	41.6	26.5	38.3	–	8.0	–	∅4	∅4	1.0	7

Runner blocks, low profile

* Scraper plates for runner blocks without a rail seal cover strip start at size 35 Part numbers: R1620 .10 30

Accessories for Standard Runner Blocks

Lubrication Plate

– Material: Aluminum

Versions:

- Standard (for standard lube nipple)
- G 1/8 Connection

Mounting instructions:

The parts required to mount the optional attachments on the runner block are supplied together with the standard parts.

Size 25 - 65:

The runner block lube nipple can be used.

Size 15 and 20:

A funnel-type lube nipple with a knock-in spigot is supplied ready for insertion.

For mounting details, see "Mounting Instructions for Ball Rail Systems".

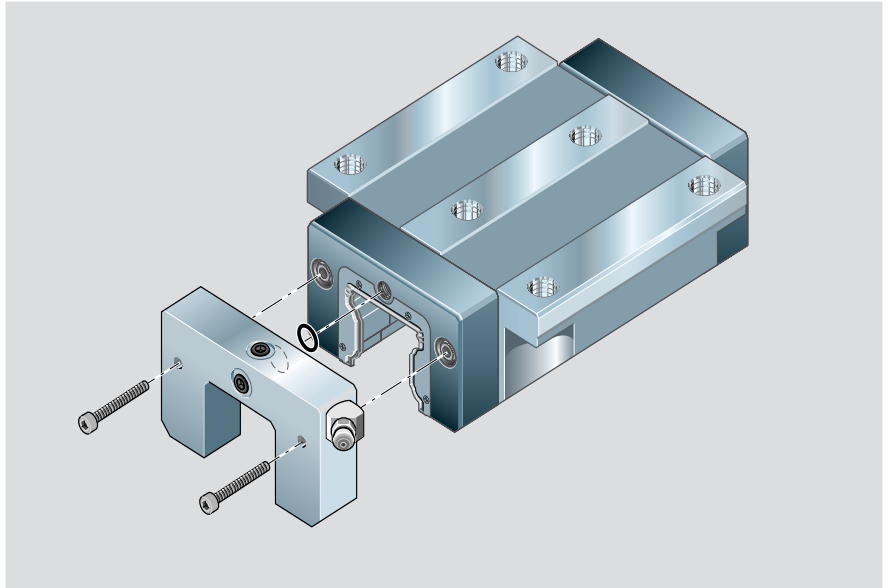

Standard lubrication plate

Part numbers, dimensions and masses.

Size	Part numbers	Dimensions (mm)								Mass (g)
		A ₄	B ₃	H	H ₃	N ₈	N ₉	S ₈	S ₉	
15	R1620 111 20	32	11	24	19.0	3.4	5.5	ø3	M3	15
20	R1620 811 20	42	12	30	24.8	3.5	6.0	ø3	M3	25
25	R1620 211 20	47	12	36	28.3	6.0	6.0	M6	M3	30
30	R1620 711 20	59	12	42	33.8	8.0	6.0	M6	M6	45
35	R1620 311 20	69	12	48	39.1	8.0	6.0	M6	M6	60
45	R1620 411 20	85	12	60	48.5	8.0	6.0	M6	M6	85
55	R1620 511 20	98	12	70	56.0	9.0	6.0	M6	M6	115
65	R1620 611 20	124	14	90	75.7	18.0	7.0	M8x1	M8x1	250

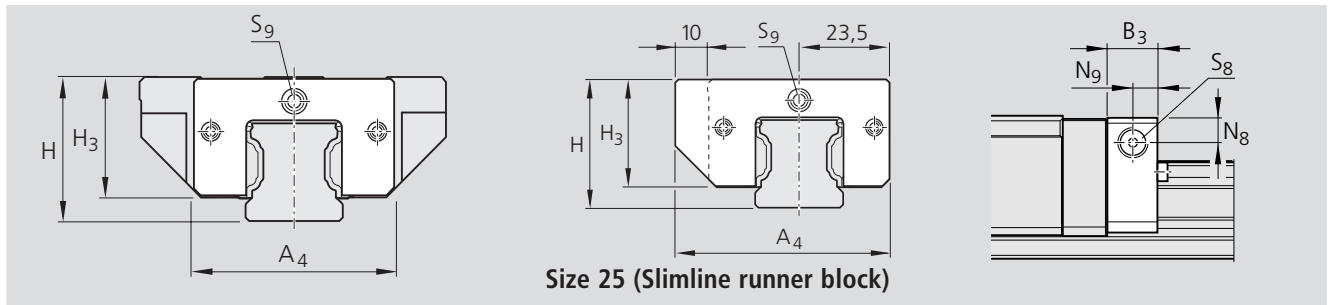

Size 25 (Slimline runner block)

Lubrication plate G 1/8

Part numbers, dimensions and masses.

With slimline runner block size 25, remember that the lubrication plate will project at the side.

Size	Part numbers	Dimensions (mm)								Mass (g)
		A ₄	B ₃	H	H ₃	N ₈	N ₉	S ₈		
25	R1620 211 30	57	16	36	28.3	7.0	8	G 1/8 - 8 deep	40	
30	R1620 711 30	59	16	42	33.8	7.0	8	G 1/8 - 8 deep	59	
35	R1620 311 30	69	16	48	39.1	8.0	8	G 1/8 - 8 deep	79	
45	R1620 411 30	85	16	60	48.5	8.0	8	G 1/8 - 8 deep	112	
55	R1620 511 30	98	16	70	56.0	9.0	8	G 1/8 - 8 deep	152	
65	R1620 611 30	124	16	90	75.7	18.0	8	G 1/8 - 8 deep	285	

Accessories for Standard Runner Blocks

Two-piece Viton seal

- Material:
corrosion-resistant steel plus Viton seal

Mounting:

The mounting screws as well as the longer lube nipple are supplied.

Simple mounting and removal if guide rail secured.

Observe the mounting instructions.

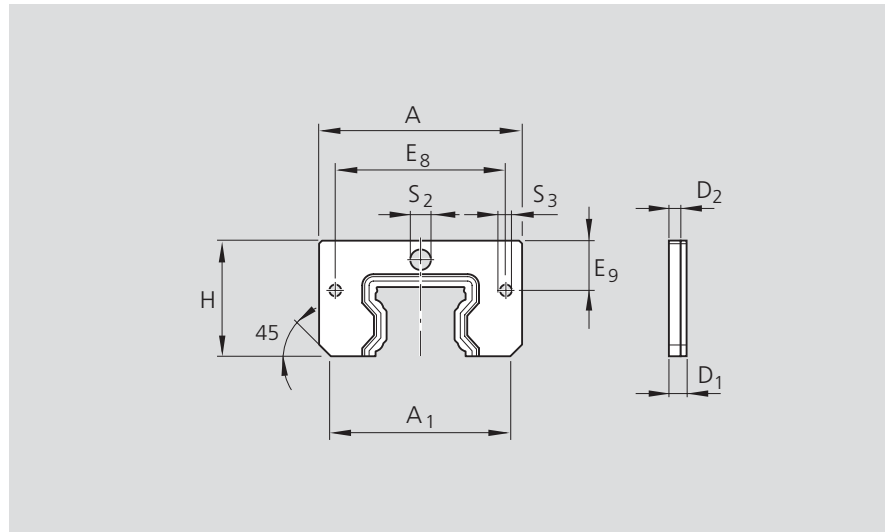

Size	Part numbers	Dimensions (mm)									Mass (g)
		A	A ₁	H	E ₈	E ₉	S ₂	S ₃	D ₁	D ₂	
35	R1619 320 30	69	61	39.5	58.0	17.0	ø7	ø4	6.0	4.0	39.0
45	R1619 420 30	85	77	49.5	69.8	20.5	ø7	ø5	6.0	4.0	61.0
55	R1619 520 30	85	77	56.4	80.0	21.8	ø7	ø6	6.0	4.0	80.5

One-piece Viton seal for mounting on the runner block

- Material:
Corrosion-resistant steel in fixed combination with Viton seal

Mounting:

The mounting screws as well as the longer lube nipple are supplied.

Observe the mounting instructions.

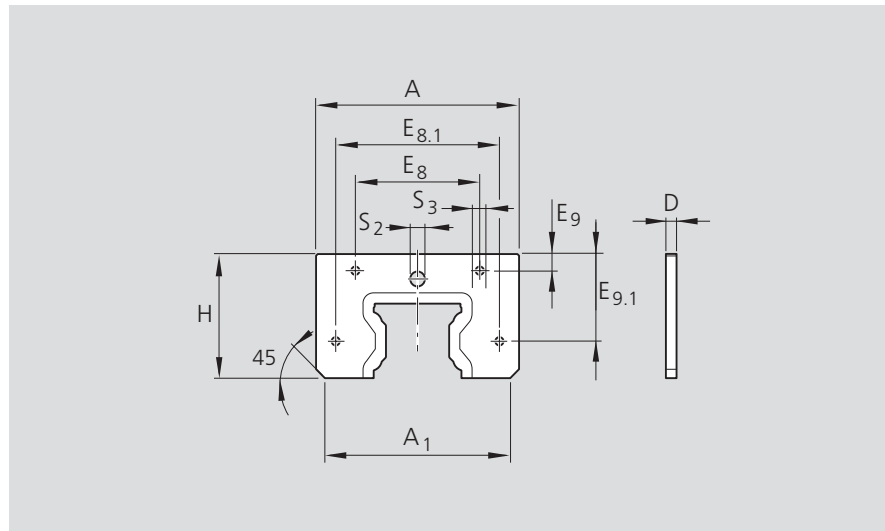

Size	Part numbers	Dimensions (mm)									Mass (g)
		A	A ₁	H	E _{8.1}	E ₉	E _{9.1}	S ₂	S ₃	D	
65	R1619 620 30	124	113.2	74.7	76	100	10	52.5	ø9	ø6.5	65

Accessories for Standard Runner Blocks

Protective bellows

- Material: bellows-type protective cover of polyurethane-coated polyester fabric
 - Aluminum lubrication plates
- The runner block lube nipple can be used.

Heat resistant bellows

- Material: bellows made of Nomex fabric, metallized on both sides.
 - Non combustible, non flammable
 - Resistant to sparks, welding splashes and hot chips
 - Temperature resistance:
The protective metal coating can withstand temperatures of up to 200°C
Operating temperature for the entire bellows: 100°C.
- Available in sizes 25-65.
The runner block lube nipple can be used.

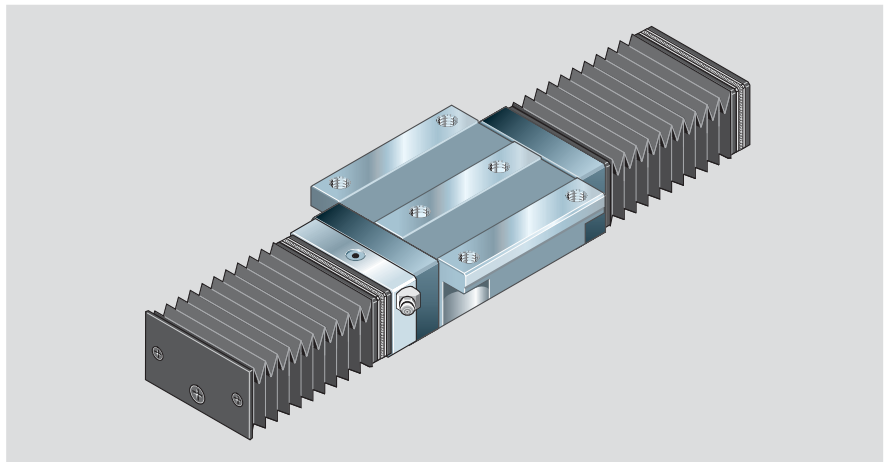

Part numbers, Bellows

Example: **R1620 306 00. 36**
folds

Standard = 0
Fire resistant = 5

Type 1 to 9
Bellows size 35, standard version.
type 6 (with FLU* and end plate).
number of folds: 36

* FLU = front lube unit

Size	Type 1 with lubrication plate and end plate		Type 2 with mounting frame and end plate		Type 3 with 2 lubrication plates	
	Type 6 with FLU* and end plate	Number of folds		Number of folds	Type 7 with 2 FLU*	Number of folds
15	R1620 10. 00	...	R1620 102 00	...	R1620 10. 00	...
20	R1620 80. 00	...	R1620 802 00	...	R1620 80. 00	...
25	R1620 20. 00	...	R1620 202 00	...	R1620 20. 00	...
30	R1620 70. 00	...	R1620 702 00	...	R1620 70. 00	...
35	R1620 30. 00	...	R1620 302 00	...	R1620 30. 00	...
45	R1620 40. 00	...	R1620 402 00	...	R1620 40. 00	...
55	R1620 50. 00	...	R1620 502 00	...	R1620 50. 00	...
65	R1620 60. 00	...	R1620 602 00	...	R1620 60. 00	...
25	R1620 25. 00	...	R1620 252 00	...	R1620 25. 00	...
30	R1620 75. 00	...	R1620 752 00	...	R1620 75. 00	...
35	R1620 35. 00	...	R1620 352 00	...	R1620 35. 00	...
45	R1620 45. 00	...	R1620 452 00	...	R1620 45. 00	...
55	R1620 55. 00	...	R1620 552 00	...	R1620 55. 00	...
65	R1620 65. 00	...	R1620 652 00	...	R1620 65. 00	...
Size	Type 4 with 2 mounting frames		Type 5 with lubrication plate and mounting frame (MF)		Type 9 Bellows. loose supply (spare part)	
		Number of folds	Typ 8 mit VSE* und BR	Number of folds		Number of folds
15	R1620 104 00	...	R1620 10. 00	...	R1600 109 00	...
20	R1620 804 00	...	R1620 80. 00	...	R1600 809 00	...
25	R1620 204 00	...	R1620 20. 00	...	R1600 209 00	...
30	R1620 704 00	...	R1620 70. 00	...	R1600 709 00	...
35	R1620 304 00	...	R1620 30. 00	...	R1600 309 00	...
45	R1620 404 00	...	R1620 40. 00	...	R1600 409 00	...
55	R1620 504 00	...	R1620 50. 00	...	R1600 509 00	...
65	R1620 604 00	...	R1620 60. 00	...	R1600 609 00	...
25	R1620 254 00	...	R1620 25. 00	...	R1600 259 00	...
30	R1620 754 00	...	R1620 75. 00	...	R1600 759 00	...
35	R1620 354 00	...	R1620 35. 00	...	R1600 359 00	...
45	R1620 454 00	...	R1620 45. 00	...	R1600 459 00	...
55	R1620 554 00	...	R1620 55. 00	...	R1600 559 00	...
65	R1620 654 00	...	R1620 65. 00	...	R1600 659 00	...

Accessories for Standard Runner Blocks

Mounting Instructions

The bellows are delivered preassembled ready for installation, complete with the screws required for attachment to the guide rail.

In types 1 and 2, thread size M4 10 mm deep and countersunk 2 x 45° must be tapped in each end face of the rail.

Size 25 - 65: The runner block lube nipple can be used.

Size 15 and 20: A funnel-type lube nipple with knock-in spigot is supplied.

For mounting details, see "Mounting Instructions for Lubrication Plates and Bellows".

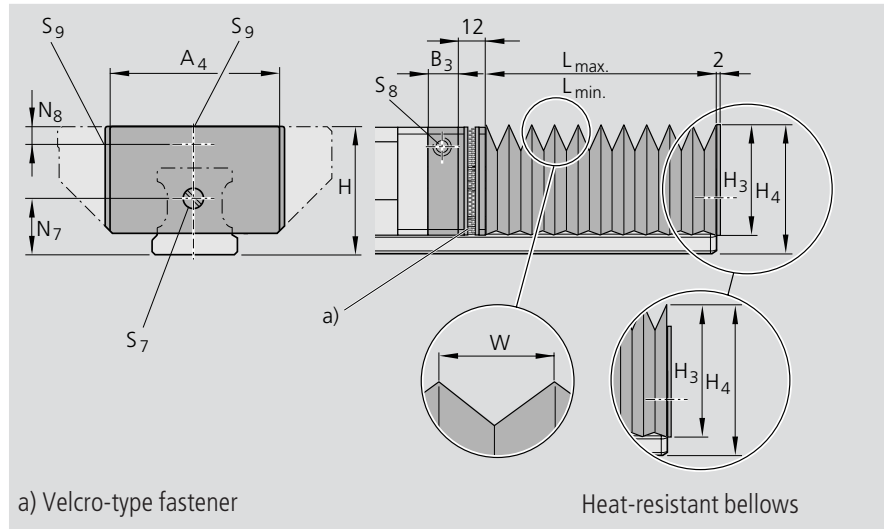

Dimensions: Bellows

Size	Dimensions (mm)											Factor	
	A ₄	B ₃	H	H ₃	H ₄	N ₇	N ₈	S ₇	S ₈	S ₉	W	U	
15	45	11	24	26.5	31.5	11	3.4	M4	∅3	M3	19.9	1.18	
20	42	12	30	24.0	29.2	13	3.5	M4	∅3	M3	10.3	1.33	
25	45	12	36	28.5	35.0	15	6.0	M4	M6	M3	12.9	1.32	
30	55	12	42	34.0	41.0	18	8.0	M4	M6	M6	15.4	1.25	
35	64	12	48	39.0	47.0	22	8.0	M4	M6	M6	19.9	1.18	
45	83	12	60	49.0	59.0	30	8.0	M4	M6	M6	26.9	1.13	
55	96	12	70	56.0	69.0	30	9.0	M4	M6	M6	29.9	1.12	
65	120	14	90	75.0	89.0	40	18.0	M4	M8x1	M8x1	40.4	1.08	

Dimensions: Heat-resistant bellows

Size	Dimensions (mm)											Factor	
	A ₄	B ₃	H	H ₃	H ₄	N ₇	N ₈	S ₇	S ₈	S ₉	W	U	
25	62	12	36	39.0	44.5	15	6.0	M4	M6	M3	25.9	1.25	
30	67	12	42	42.0	47.5	18	8.0	M4	M6	M6	25.9	1.25	
35	76	12	48	47.0	54.0	22	8.0	M4	M6	M6	29.9	1.21	
45	90	12	60	55.0	64.0	30	8.0	M4	M6	M6	32.9	1.18	
55	104	12	70	63.0	75.0	30	9.0	M4	M6	M6	37.9	1.16	
65	134	14	90	86.0	99.0	40	18.0	M4	M8x1	M8x1	37.9	1.16	

Bellows design formulas

$$L_{max} = (\text{Stroke} + 30) \cdot U$$

$$L_{min} = L_{max} - \text{Stroke}$$

$$\text{No. of folds} = \frac{L_{max}}{W} + 2$$

L_{max} = Bellows extended

L_{min} = Bellows compressed

Stroke = Stroke (mm)

U = Calculation factor

W = Maximum extension (mm)

Rail length formula

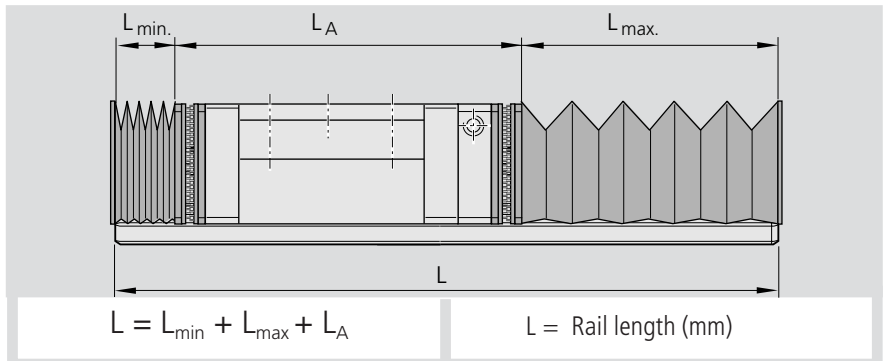

Accessories for Standard Runner Blocks

Lubrication adapter

For high runner blocks:

R1621-...-2./-7./-8.

R1624-...-2./-7./-8.

- Material: plastic
- Content: 1 unit

Mounting instructions:

The parts required to mount the optional attachments on the runner block are supplied together with the standard parts.

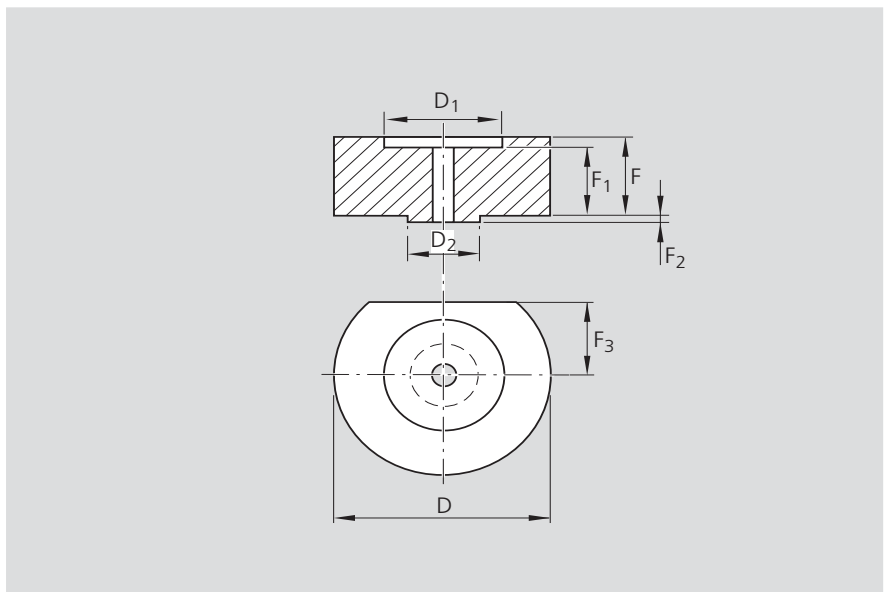
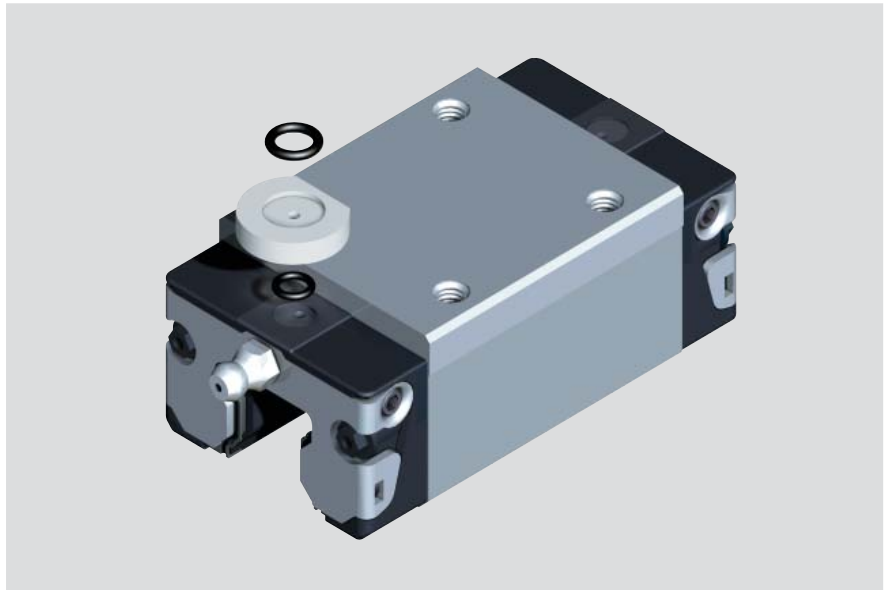

Part numbers and dimensions

Size	Part numbers	Dimensions (mm)						
		D	D ₁	D ₂	F	F ₁	F ₂	F ₃
15	R1621 100 05	12	6.2	3.4	3.70	3.10	0.50	3.20
25	R1621 200 05	15	7.2	4.4	3.80	3.20	0.50	5.85
30	R1621 700 05	16	7.2	4.4	2.80	2.20	0.50	6.10
35	R1621 300 05	18	7.2	4.4	6.80	6.20	0.50	6.80
45	R1621 400 05	20	7.2	4.4	9.80	9.20	0.50	8.30

Accessories for Standard Runner Blocks

Mounting lubrication adapter

A lubrication adapter is required for high runner blocks if lubrication is to be carried out from the table section.

⚠ In the recess for the O-ring, a further small recess (1) has been pre-formed. Do not open this with a drill bit. Danger of contamination!

- Preheat the metal tip (2) with a diameter of 0.8 mm.
- Carefully open the recess (1) with the metal tip and pierce through it. Observe the maximum permissible depth T_{max} indicated in the table!
- Insert O-ring (3) in the recess.
- Insert lubrication adapter at an angle in the recess and press the flattened side (4) against the steel section (5). Use grease when locating.
- Insert O-ring (6) in the lubrication adapter.

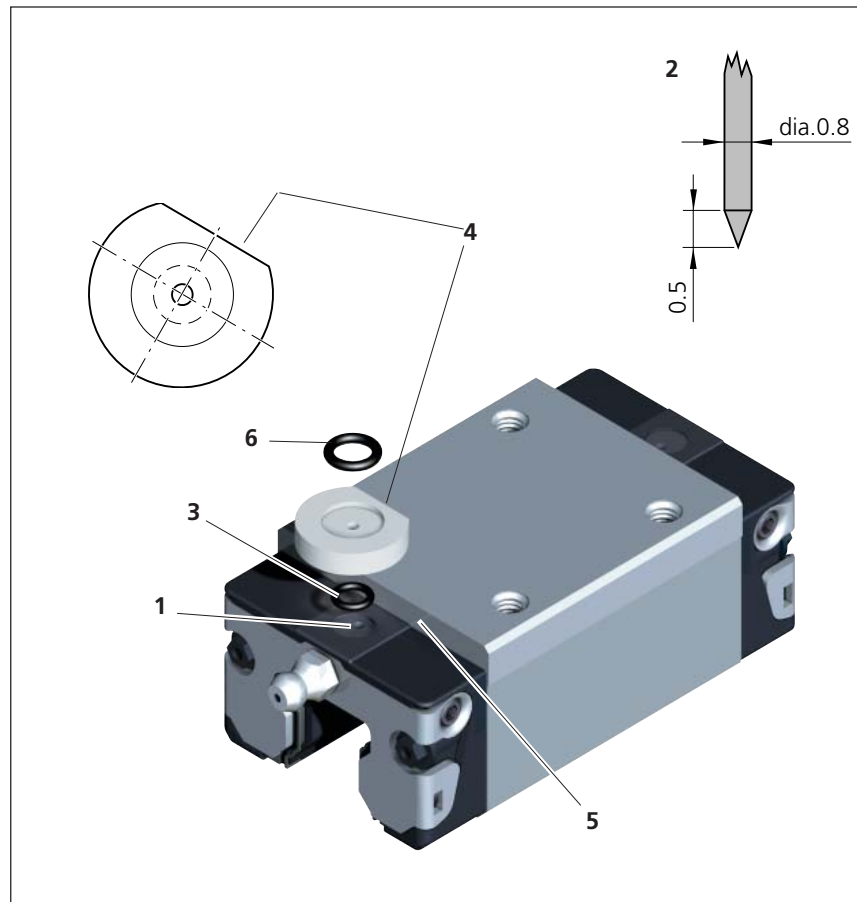

Size	Lube hole at top: max. perm. depth for piercing T_{max} (mm)
15	3.6
20	3.9
25	3.3
30	6.6
35	7.5
45	8.8

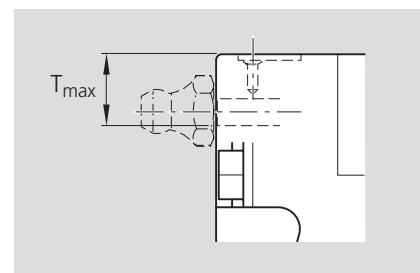

Accessories for Standard Runner Blocks

Front Lube Unit

Advantages during mounting and in service:

- Only initial lubrication of the runner block necessary
- Up to 10 000 km travel life without in-service lubrication
- Front lube units at both runner block ends
- Minimal lubricant loss
- Reduced oil consumption
- No lubricant lines
- Max. operating temperature 60C°
- With lube nipple, side filling option of front lube unit
- Lube port on end face suitable for lubricating runner block with grease

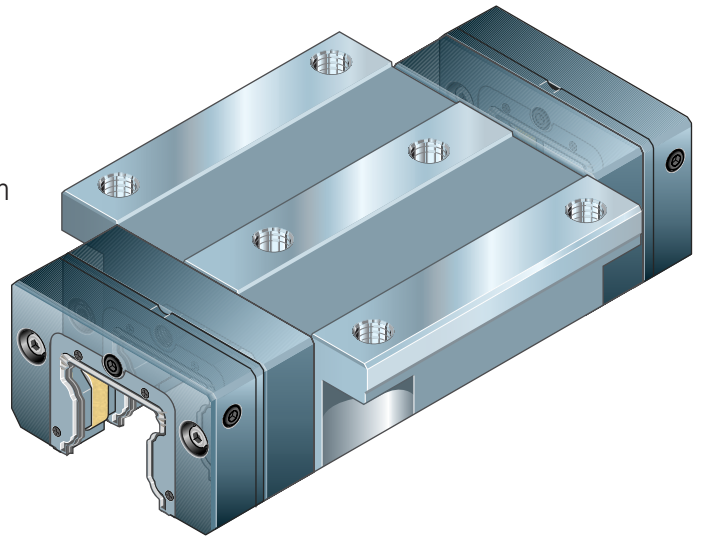

Runner block with two front lubrication units

Size	Travel under normal operating conditions
	Travel (km)
	Load ≤ 0.15 C
15	10 000
20	10 000
25	10 000
30	10 000
35	10 000
45	2 500
55	1 500
65	1 000

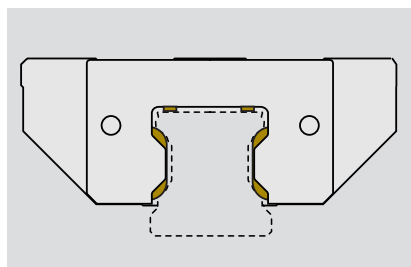
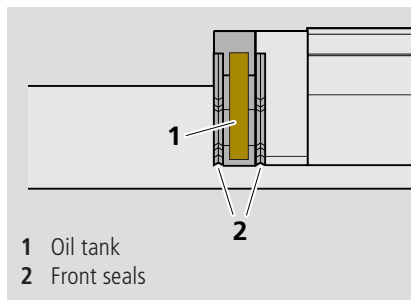

Specially designed oil distribution channels ensure that lubricant is applied only where needed: directly to the ball tracks and the guide rail surfaces.

Oil consumption comparison (ball rail system size 25)

Front lubrication units	Lubricant quantity per lubrication cycle (cm ³)	Travel (m)	Consumption (cm ³ /km)
without	1.2	20 000	0.06 → 100 %
with	5.2	5 000 000	0.00104 → 1.73 %

Accessories for Standard Runner Blocks

Front Lube Units for Ball Rail Systems

– Material: special plastic.

Mounting:

Comes complete with coated mounting screws and lubricating nipple.

Front lube units with the part numbers stated below: ...-00 are supplied ready-filled with oil and can be mounted immediately after greasing the runner block.

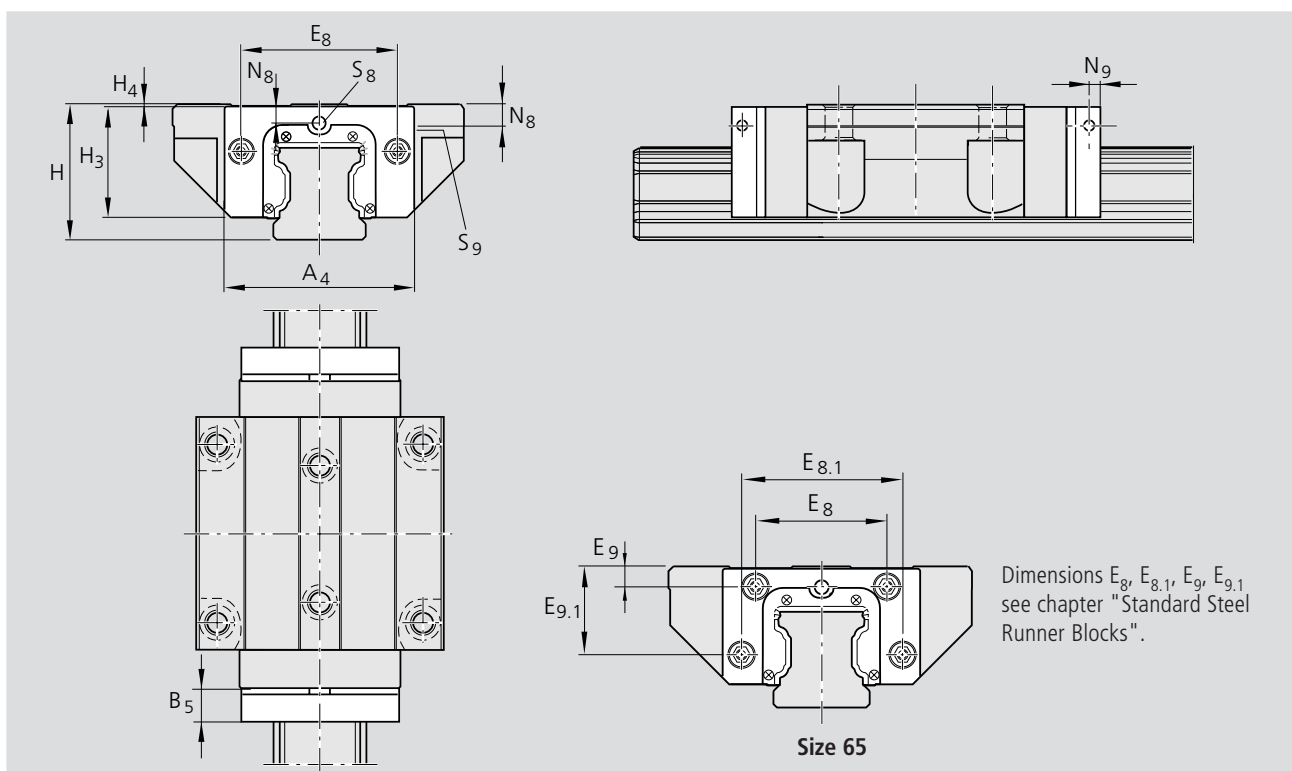
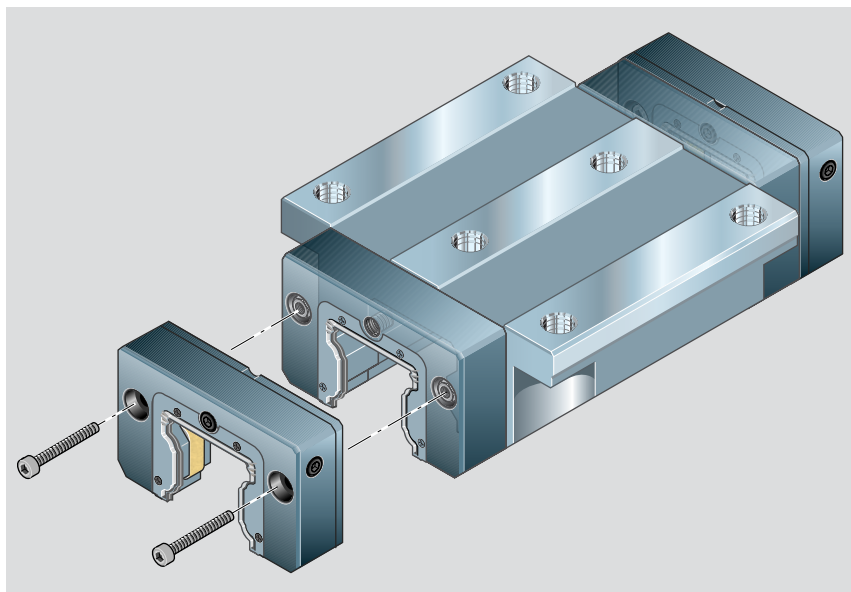

Part numbers, dimensions

Size	Part numbers	Dimensions (mm)										Oil (cm ³)
		A ₄	B ₅	H	H ₃	H ₄	N ₈	N ₉	S ₈	S ₉		
15	R1619 125 00	31.8	11.5	24	19.2	0.20	3.4	5	M3	M3	1.00	
20	R1619 825 00	43.0	12.5	30	24.4	0.50	3.4	5	M3	M3	2.20	
25	R1619 225 00	47.0	13.0	36	28.8	0.50	5.2	5	M6	M6	2.60	
30	R1619 725 00	58.8	14.5	42	34.3	0.75	5.5	6	M6	M6	3.85	
35	R1619 325 00	69.0	16.0	48	39.3	0.55	6.6	6	M6	M6	5.70	
45	R1619 425 00	84.0	17.0	60	49.3	0.50	8.0	7	M6	M6	9.60	
55	R1619 525 00	99.0	18.0	70	56.3	0.75	8.5	8	M6	M6	14.50	
65	R1619 625 00	124.2	19.0	90	74.7	1.00	15.2	8	M8	M8	30.00	
20	R1619 826 00	41.0	12.5	28	22.4	0.50	2.4	–	M3	–	1.8	
25	R1619 226 00	47.0	13.0	33	25.8	0.50	3.8	5	M6	M3	2.5	

Ball rail systems, low profile

Accessories for Standard Runner Blocks

Initial Lubrication of the Runner Blocks

! Prior to mounting the front lube units, initial lubrication of the runner block **with lubrication grease** may be required!

Recommended lubrication greases:

- Paragon EP 1. DEA. KP 1 N-30
- Optimol Longtime PD 1. [made by] Optimol Ölwerke. KP 1 N-40
- Optimol Longtime PD 2. [made by] Optimol Ölwerke. KP 2 N-40
- Klüber Isoflex NCA 15
- Klüber Polylub GLY 151
- Klüber Microlube GL 261

Lubrication of the runner blocks

☞ If there is already lubricant in the runner block, or if other lubrication greases other than those recommended have to be used: see "Compatibility of Lubricants".

1. Lubricate runner blocks according to table.
2. Slide runner block back and forth over at least three times the block length for three full cycles.
3. Repeat steps 1. and 2. two more times
4. Check whether a film of lubricant is visible on the guide rail.

Size	Partial lubricant quantity for initial lubrication of the runner block (cm ³)
15	0.4
20	0.7
25	1.4
30	2.2
35	2.2
45	4.7
55	9.4
65	15.4

Front Lube Unit

Shipped Condition

There are two versions of front lube units. The part numbers mean:

.....-00: ready for mounting, filled with lubrication oil

.....-10: without lubrication oil

Initial filling of a front lube unit without oil (part numbers-10)

Recommended lubrication oil:

- Mobil SHC 639 (viscosity 1000 mm²/s at 40 °C)

☞ If other lubricants have to be used: see "Compatibility of Lubricants".

- Remove the set screw from the lube bore (1) and keep in a safe place.
- Screw in the lube nipple (2).
- Lay the front lube units (3) out flat; fill the oil quantity listed in the table; leave to settle for approx. 36 hours.

- Check whether the lube insert is completely soaked in oil. If necessary, add oil.
- Remove the lube nipple. Tighten the set screw.

Size	Oil quantity for initial filling of front lube unit (cm ³)
15	0.9
20	2.0
25	2.4
30	3.85
35	5.7
45	9.6
55	14.5
65	30.0

- For size 20 low profile: place the front lube units in 10 cm of oil for approx. 36 hours (☞ Fig. B).

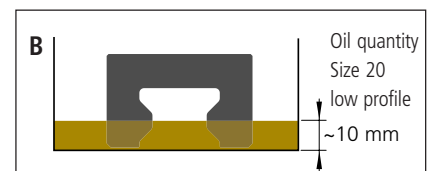
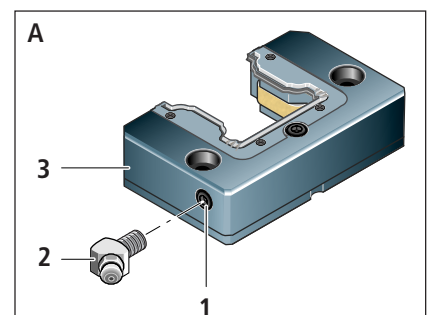

Compatibility of Lubricants

Synthetic lubricants are superior to those based on mineral oils., especially paraffin oils.

The standard oil filling in the front lube units is Mobil SHC 639.

This oil is a fully synthetic lubricant based on synthetic hydrocarbons (polyalphaolefine).

Mobil SHC 639 can be mixed with mineral oils in any ratio. Compatibility with Rexroth corrosion-protection oil is ensured.

Mobil SHC 639 is also chemically compatible with lubrication greases whose base oil is synthetic hydrocarbon oil, polyalphaolefin, mineral oil or ester oil.

! If other lubricants are used. check the compatibility of lubrication oil and lubrication grease.

Minimum requirements for lubrication oils: oils of the ISO viscosity class 1000, in accordance with DIN 51519, without solid lubricant content e.g.: lubrication oil CLP according to DIN 51517, part 3.

☞ The lubrication oils must be chemically and physically comparable with Mobil SHC 639.

! Incompatibilities are to be expected in particular with lubrication greases whose base oil is silicone oil, polyglycol oil, polyphenylether oil or perfluoralkylether oil.

Accessories for Standard Runner Blocks

Mounting Front Lube Units

Comes complete with coated mounting screws, additional front seals and lubricating nipple.

⚠ Mount one front lube unit (3) on each side of the runner block!

⚠ Do not take the runner block off the guide rail!

- Push on the front lube units (3).
- Remove set screws (5) and insert O-rings (6) between the runner block and front lube units.
- Tighten the screws (4) with tightening torque M_A .

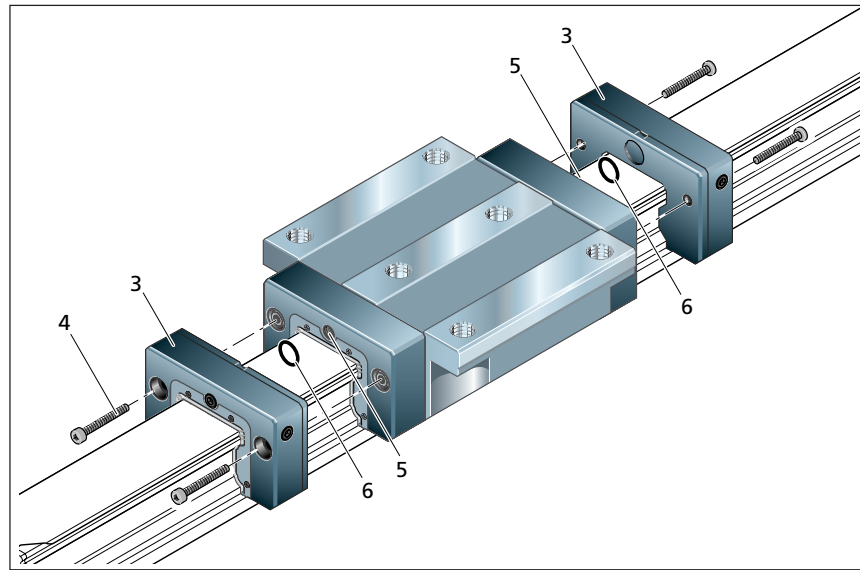

		MA (Nm)
15	M2.5 x 12	0.3
20	M3 x 14	0.4
25	M3 x 14	0.7
30	M3 x 14	0.7
35	M3 x 16	0.7
45	M4 x 18	1.0
55	M5 x 18	1.3
65	M4 x 20	1.0

In-service lubrication intervals for runner blocks

- Check front lube units if travel life does not match that in table.

The travel life applies with:

- Normal operating conditions and load in accordance with table.

On reaching the travel life in the table or at the latest after 3 years, we recommend that you replace the front lube units and grease the runner block before mounting the new front lube unit. Under clean operating conditions, the runner block front faces can be lubricated by the front lube unit with grease. The front lube units can be filled with oil.

Lubrication quantities, see "Initial Lubrication of the Runner Block" and "Initial Filling of a Front Lube Unit Without Oil".

 In ongoing service life tests, longer travel lives have already been achieved. Please ask for information if required!

Size	Travel life under normal operating conditions
	Travel (km)
	Load $\leq 0.15 C$
15	10 000
20	10 000
25	10 000
30	10 000
35	10 000
45	2 500
55	1 500
65	1 000

⚠ The intervals of the in-service lubrication recommendation depend on the ambient influences, load and type of load.

Ambient influences are, for example, fine swarf, mineral and similar abrasion, solvents and temperature.

Load and the type of load are, for example, vibrations, bumps and tilts.

⚠ The manufacturer is unaware of the conditions of use. Security with regard to in-service lubrication intervals can only result from the user's own tests or precise observations.

⚠ Do not use diluted cooling lubricant on guide rails and runner blocks!

Accessories for Standard Guide Rails

Overview of Accessories and Allocation

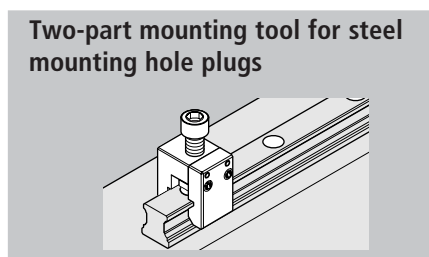
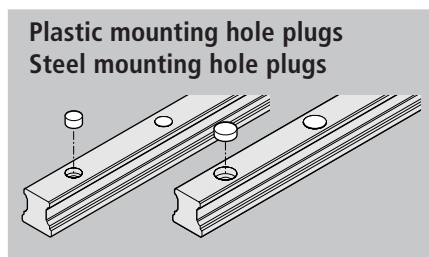
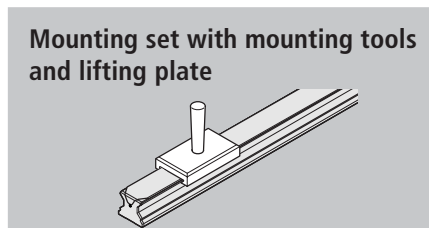
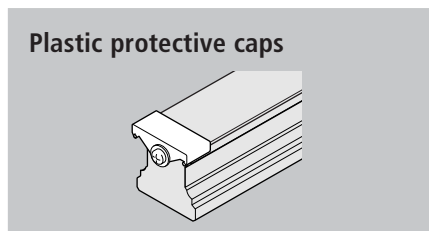
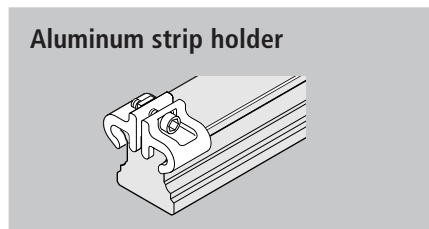
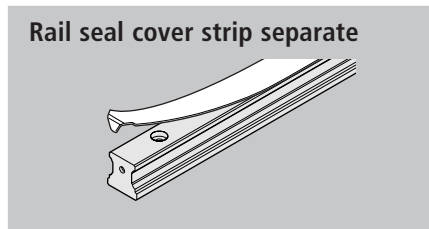
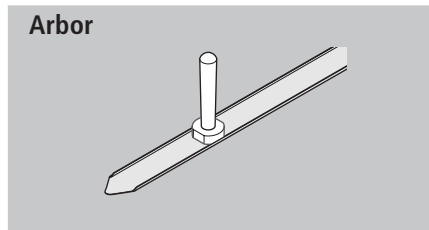

Standard Guide Rails

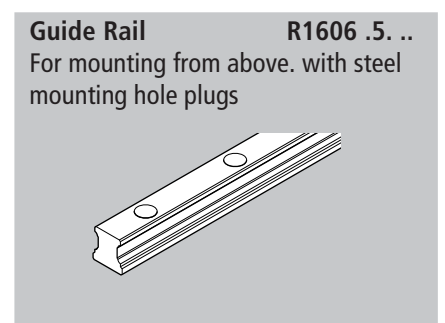
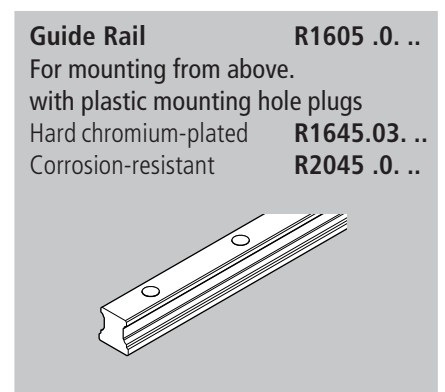
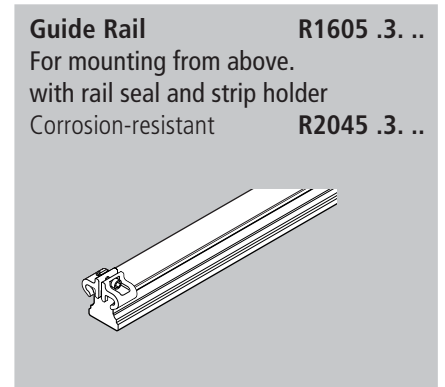

Mounting Accessories

Mounting accessories, see Mounting Instructions for Ball Rail Systems RE 82 270

Notes on rail seal cover strip

Advantages of the rail seal

The rail seal is easy to clip on and remove.

- This considerably facilitates and speeds up the mounting process:
 - no need to plug each single hole
 - no time delay while waiting for adhesive to harden when using adhesive tape
- The rail seal can be mounted and removed (up to 4 times)

The rail seal is a precision-machined part that must be handled with great care. It must on no account be bent.

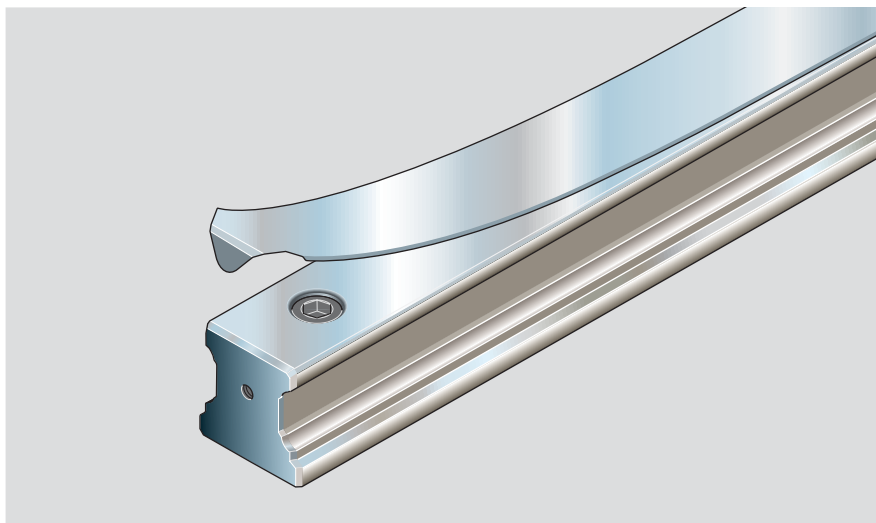

Versions/Functions

A Snap-fit rail seal (standard)

- The rail seal is clipped on before the runner block is mounted and fits tightly.

B Sliding-fit rail seal

- For mounting or replacing a rail seal when the runner block or superstructure cannot be removed.
- A section of the snap-fit rail seal is very slightly widened and can then be easily slid under the runner block.

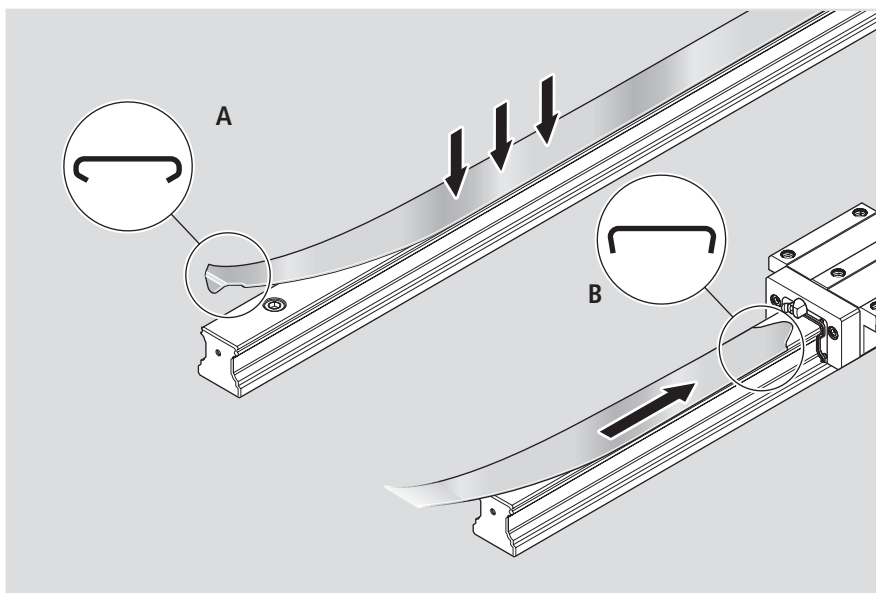

An arbor (available as an option) for 0.15 mm rail seals or a special expanding tool for 0.3 mm rail seals can be used to create the sliding fit after installation in order to be able to remove a rail seal.

The main advantage is that the length **X** of the sliding fit can be optimized to suit the installation conditions.

Observe the detailed mounting instructions!

Part numbers, see chapter "Accessories for Standard Guide Rails".

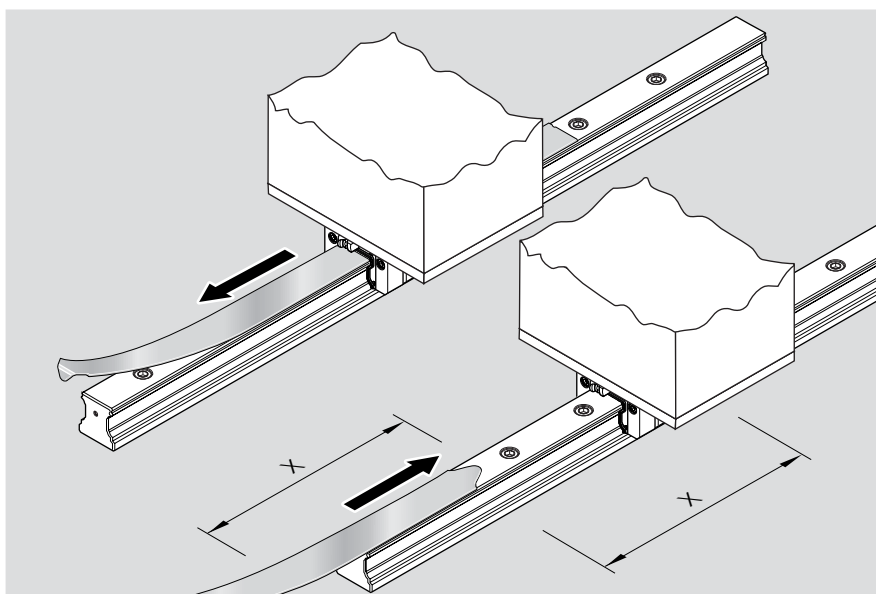

Accessories for Guide Rails

Rail seal cover strip separate for initial mounting/storage/ replacement

A suitable rail seal cover strip with firm seating or rail seal cover strip with sliding fit is available for every guide rail length.

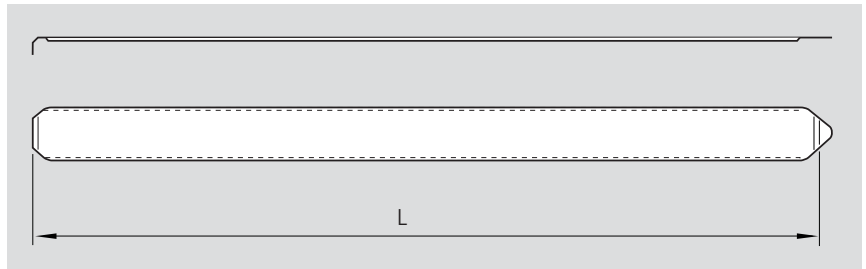

Ordering a standard rail seal cover strip with firm seating

Ordering example:

Guide rail, size 35.
Rail length $L = 2696$ mm

Ordering data:

Part number, length L (mm)

R1619 330 20, 2696 mm

(part numbers, see product table)

Size	Standard rail seal Part numbers, length (mm)
15	R1619 130 00, ...
20	R1619 830 00, ...
25	R1619 230 00, ...
30	R1619 730 00, ...
35	R1619 330 20, ...
45	R1619 430 20, ...
55	R1619 530 20, ...
65	R1619 630 20, ...

Ordering a rail seal cover strip with firm seating and sliding fit

Ordering example:

Guide rail, size 35.
Rail length $L = 2696$ mm
Length of the sliding fit $L_S = 1200$ mm

Ordering data:

Part number, length L (mm),
length of the sliding fit L_S (mm)

R1619 330 30, 2696, 1200 mm

(Part numbers, see product table)

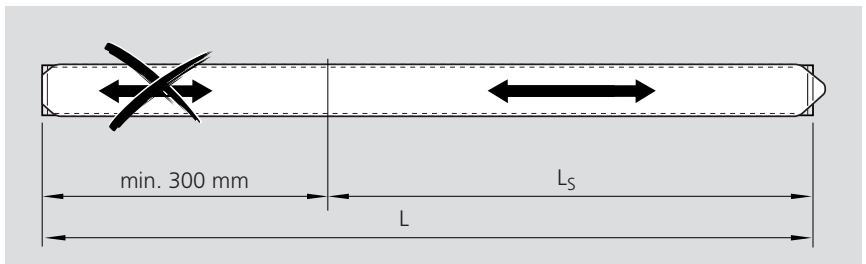

L_S = length of the sliding fit
 L = rail length

Size	Rail seals with sliding fit Part numbers, length (mm)
15	R1619 130 10, ...
20	R1619 830 10, ...
25	R1619 230 10, ...
30	R1619 730 10, ...
35	R1619 330 30, ...
45	R1619 430 30, ...
55	R1619 530 30, ...
65	R1619 630 30, ...

Accessories for Guide Rails

Mounting Rail Seals

Mounting Tool Set for rail seal cover strip 0.3 mm

For clipping on the rail seal cover strip, there is a mounting tool (A); for removal, there is a lifting plate (B).

For more detailed information on how to mount cover strips, see "Mounting instructions for rail seal cover strip" RDEFI 82 070.

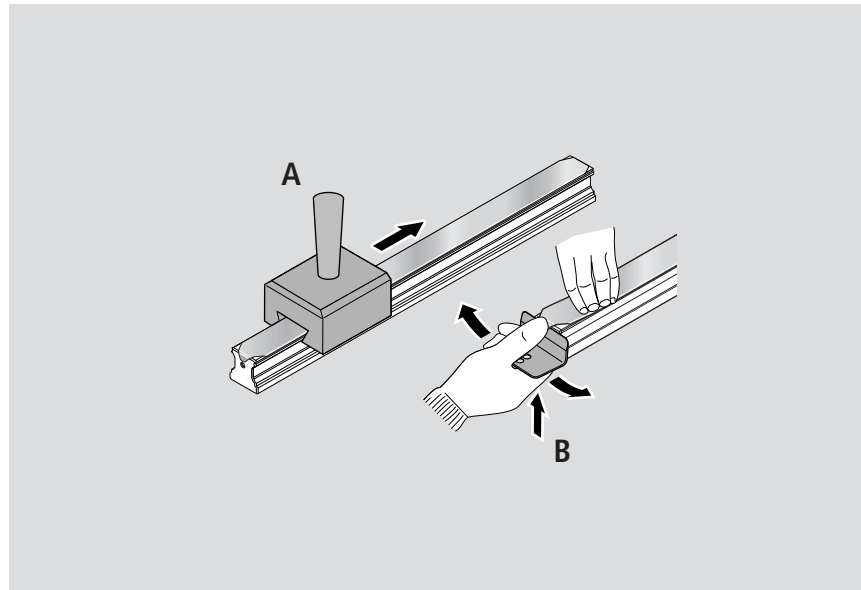

Strip holders

Rexroth uses strip holders to secure the rail seal cover strip.

Strip holders can:

- Prevent injuries
- Prevent inadvertent lifting of the strip and penetration of dirt
- Attach the rail seal cover strip

For part numbers, see chapter "Accessories for Standard Guide Rails".

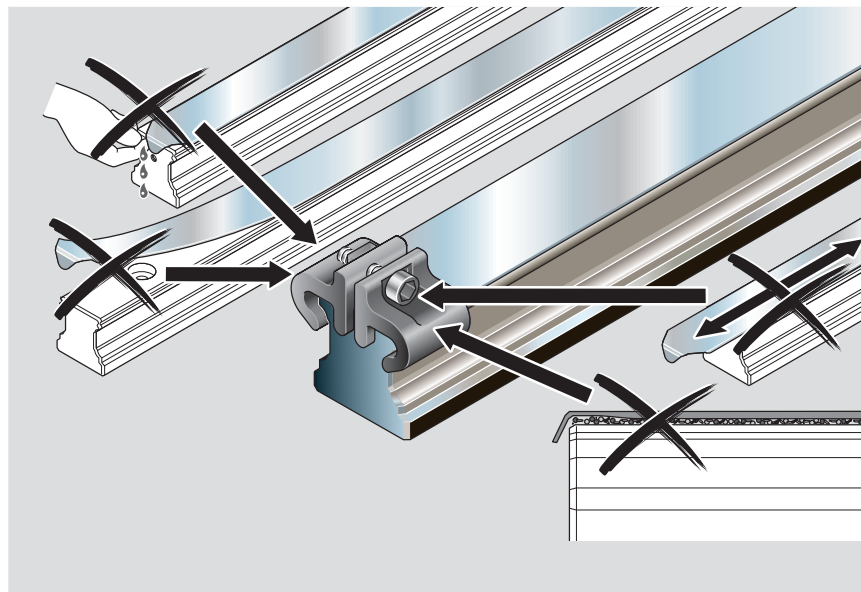

Mounting hole plugs

For more detailed information on how to mount hole plugs, see "Mounting instructions for rail seal cover strip" RDEFI 82 270.

For Part numbers of hole plugs, see chapter "Accessories for Standard Guide Rails".

Accessories for Guide Rails

Mounting tool set for rail seal cover strip

For clipping on the rail seal cover strip, there is a mounting tool (A); for removal, there is a lifting plate (B).

Size	Part number Mounting tool + lifting plate
25	R1619 210 80
30	R1619 710 80
35	R1619 310 60
45	R1619 410 60
55	R1619 510 60
65	R1619 610 60

For more detailed information on how to mount cover strips, see "Mounting instructions for rail seal cover strip" RDEFI 82 070.

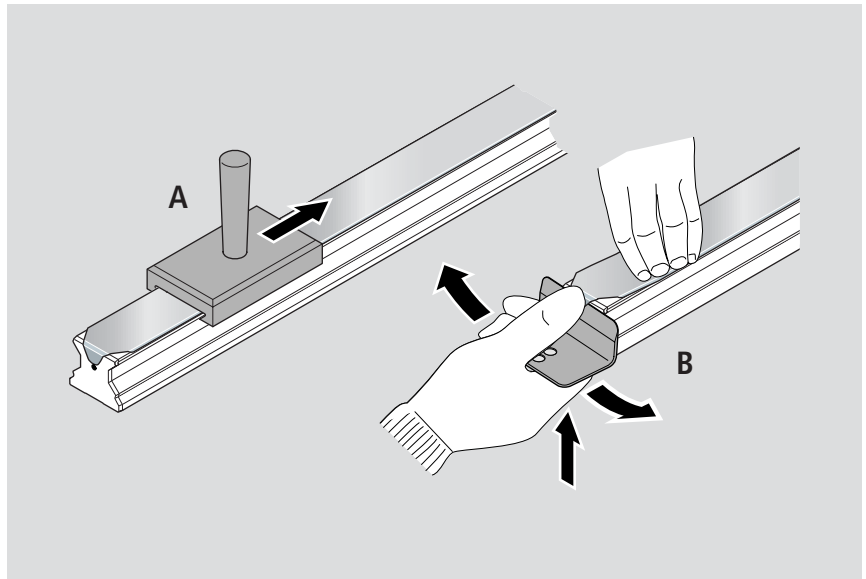

Arbor for creation of a sliding fit on rail seal cover strip

For part numbers, see product table

For more detailed information on manufacturing and mounting cover strips with sliding fit, see "Mounting instructions for the rail seal cover strip" RDEFI 82 070.

Size	Part numbers Arbor
15	R1619 115 10
20	R1619 815 10
25	R1619 215 10
30	R1619 715 10
35	R1619 315 30
45	R1619 415 30
55	R1619 515 30
65	R1619 615 30

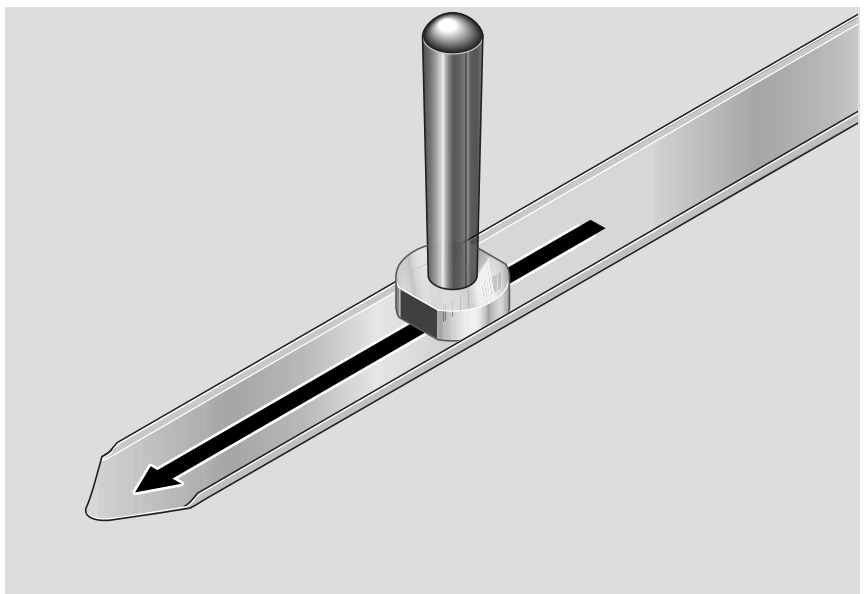

Accessories for Guide Rails

Strip holder

For guide rails without front face threaded mounting holes.

Rexroth recommends the use of a strip holder.

Strip holders can:

- Prevent inadvertent lifting of the strip and penetration of dirt
- Attach the rail seal cover strip

Materials:

Aluminum strip holder, anodized
Clamping screw and nut made of corrosion-resistant steel

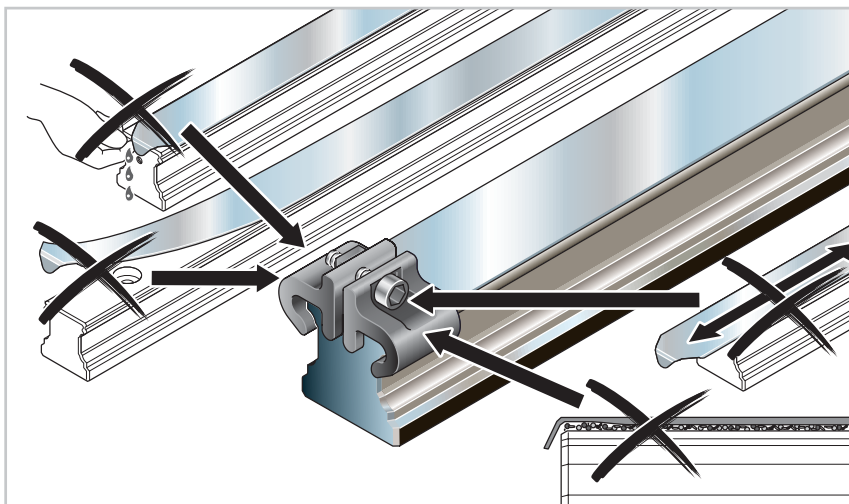

Part numbers for strip holder

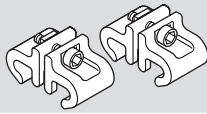
Size	Strip holder (2 per unit) Part numbers	
		
15	R1619 139 50	
20	R1619 839 50	
25	R1619 239 50	
30	R1619 739 50	
35	R1619 339 50	
45	R1619 439 50	
55	R1619 539 50	
65	R1619 639 50	

Protective caps

For guide rails with front face threaded mounting holes.

Material: Black plastic

Size	Protective caps Part numbers	
	individual	Set with screws
15	R1619 139 00	R1619 139 20
20	R1619 839 00	R1619 839 20
25	R1619 239 00	R1619 239 20
30	R1619 739 00	R1619 739 20
35	R1619 339 00	R1619 339 20
45	R1619 439 00	R1619 439 20
55	R1619 539 00	R1619 539 20
65	R1619 639 00	R1619 639 20

Accessories for Guide Rails

Plastic hole plugs

Size	Part numbers Plastic hole plugs
15	R1605 100 80
20	R1605 800 80
25	R1605 200 80
30	R1605 300 80
35	R1605 300 80
45	R1605 400 90
55	R1605 500 90
65	R1605 600 90

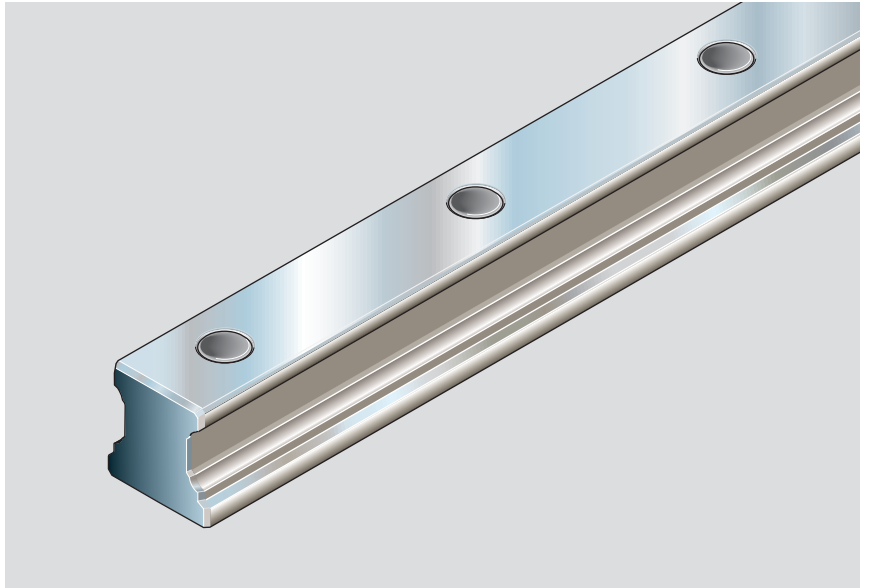

Steel mounting hole plugs

Size	Part numbers for Mounting Hole plugs made of steel
25	R1606 200 75
30	R1606 300 75
35	R1606 300 75
45	R1606 400 75
55	R1606 500 75
65	R1606 600 75

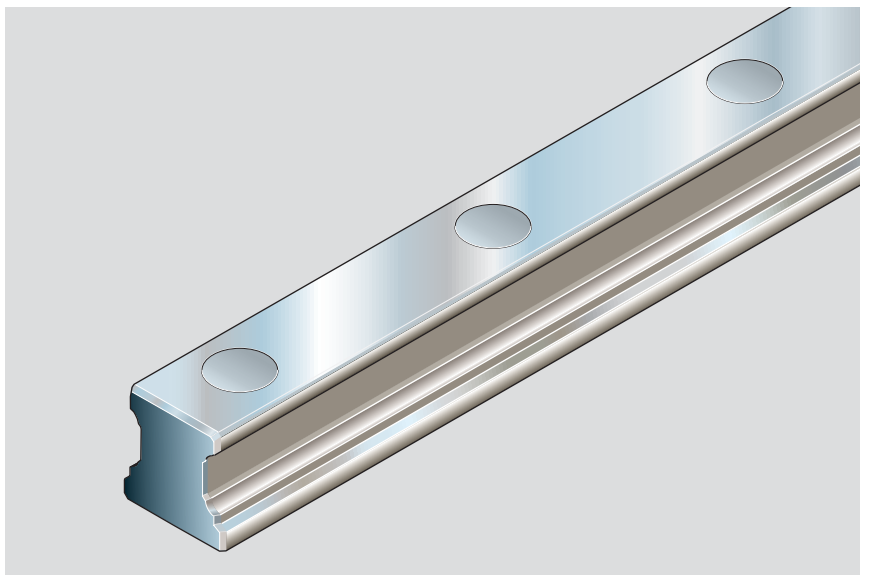

Mounting tool for steel mounting hole plugs

Two-piece

A mounting tool with instruction leaflet is available for mounting steel mounting hole plugs.

Size	Part numbers Two-piece mounting tool
25	R1619 210 00
30	R1619 710 00
35	R1619 310 10
45	R1619 410 10
55	R1619 510 10
65	R1619 610 00

-00: one-piece

-10: two-piece

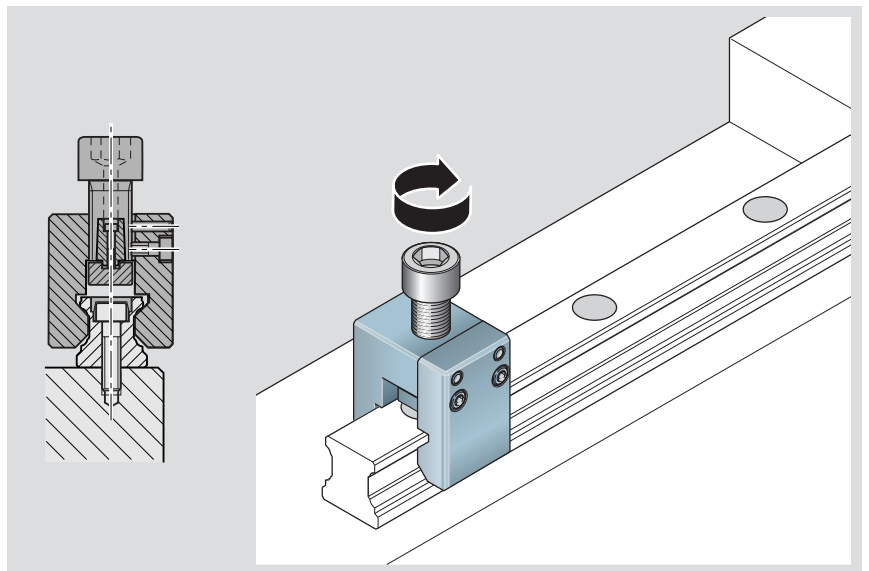

Product Description, Wide Ball Rail Systems

Excellent properties

- Due to very high moment and torsional rigidity, particularly suitable for single rail applications
- High torque load capacity
- Optimized entry-zone geometry and the high number of balls per track greatly reduce fluctuation in elastic deflection

Further Highlights

- Integral, all-round sealing
- Innovative cage design allows for longer lubrication intervals
- At both end faces, 4 lubrication connections each, making it extremely easy to maintain
- End face mounting holes for attachment of bellows or scraper plates
- Guide rails and runner blocks in accuracy class H
also available as Hard Chrome Plated Resist CR
- Guide rail with low clearance or light preload
- Smooth, light running due to optimized ball recirculation and ideal ball/track geometry
- Improved rigidity under lift-off and side loading conditions when additional mounting screws are used at the center of the runner block
- Attachments can be mounted to runner block from above or below

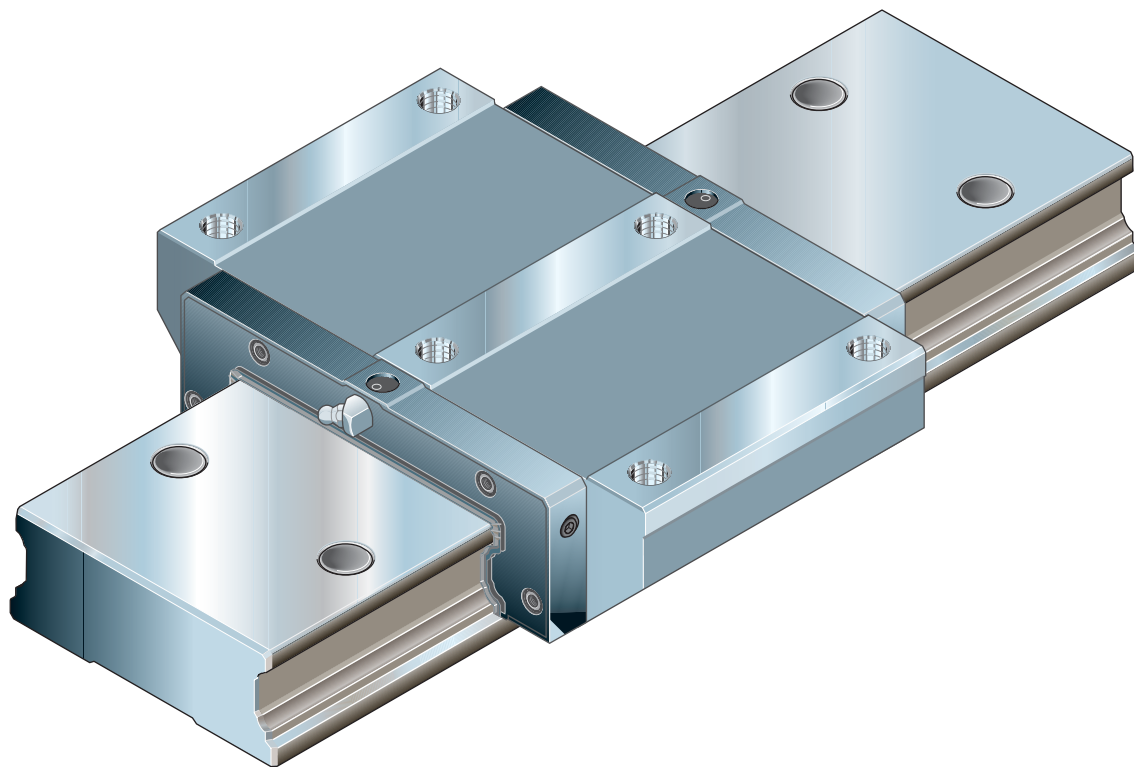

Make up your own compact linear motion guideways from interchangeable standard stock elements...

Rexroth manufactures its guide rails and runner blocks with such high precision, especially in the ball track zone, that each individual component element can be replaced by another at any time. This makes infinite combinations possible within each accuracy class.

Wide Runner Block, Steel Version

Runner Blocks BNN R1671

Wide Low Profile

Dynamic characteristics

Speed $v_{max} = 3 \text{ m/s}$
 Acceleration $a_{max} = 250 \text{ m/s}^2$

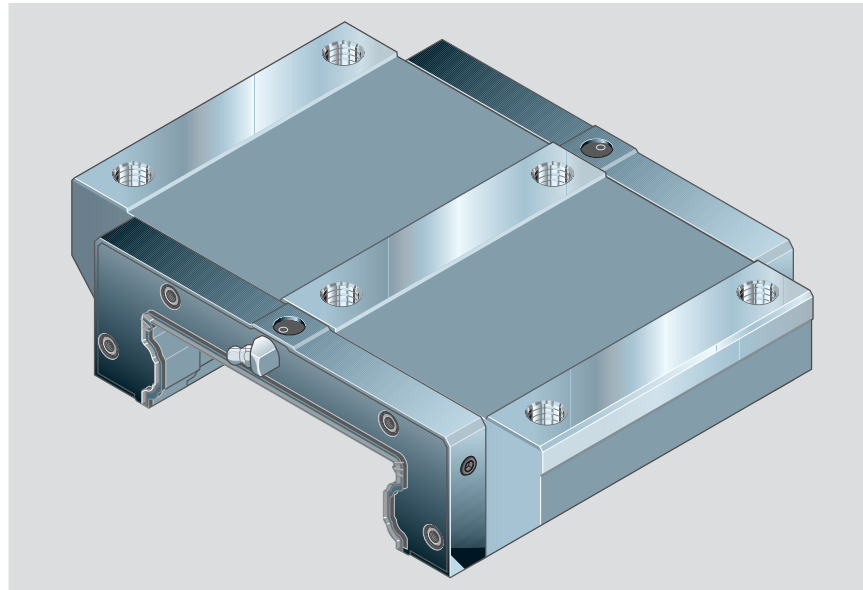

Part numbers

Size	Accuracy class	Part numbers for preload class	
		C0	C1
20/40	N	R1671 894 10	R1671 814 10
	H	R1671 893 10	R1671 813 10
	P		R1671 812 10
25/70	N	R1671 294 10	R1671 214 10
	H	R1671 293 10	R1671 213 10
	P		R1671 212 10
35/90	N	R1671 394 10	R1671 314 10
	H	R1671 393 10	R1671 313 10
	P		R1671 312 10

Note on dynamic load capacities and moments (see table)

Determination of dynamic load capacities and moments is based on a travel life of 100 000 m. However, frequently this is determined on the basis of only 50,000 m. In this case for comparison: multiply values **C**, **Mt** and **ML** by 1.26 in accordance with Rexroth table.

Preload Class

C0 = without Preload
 C1 = Preload 2% C

For further technical information, please see chapter on "General Technical Data and Calculations".

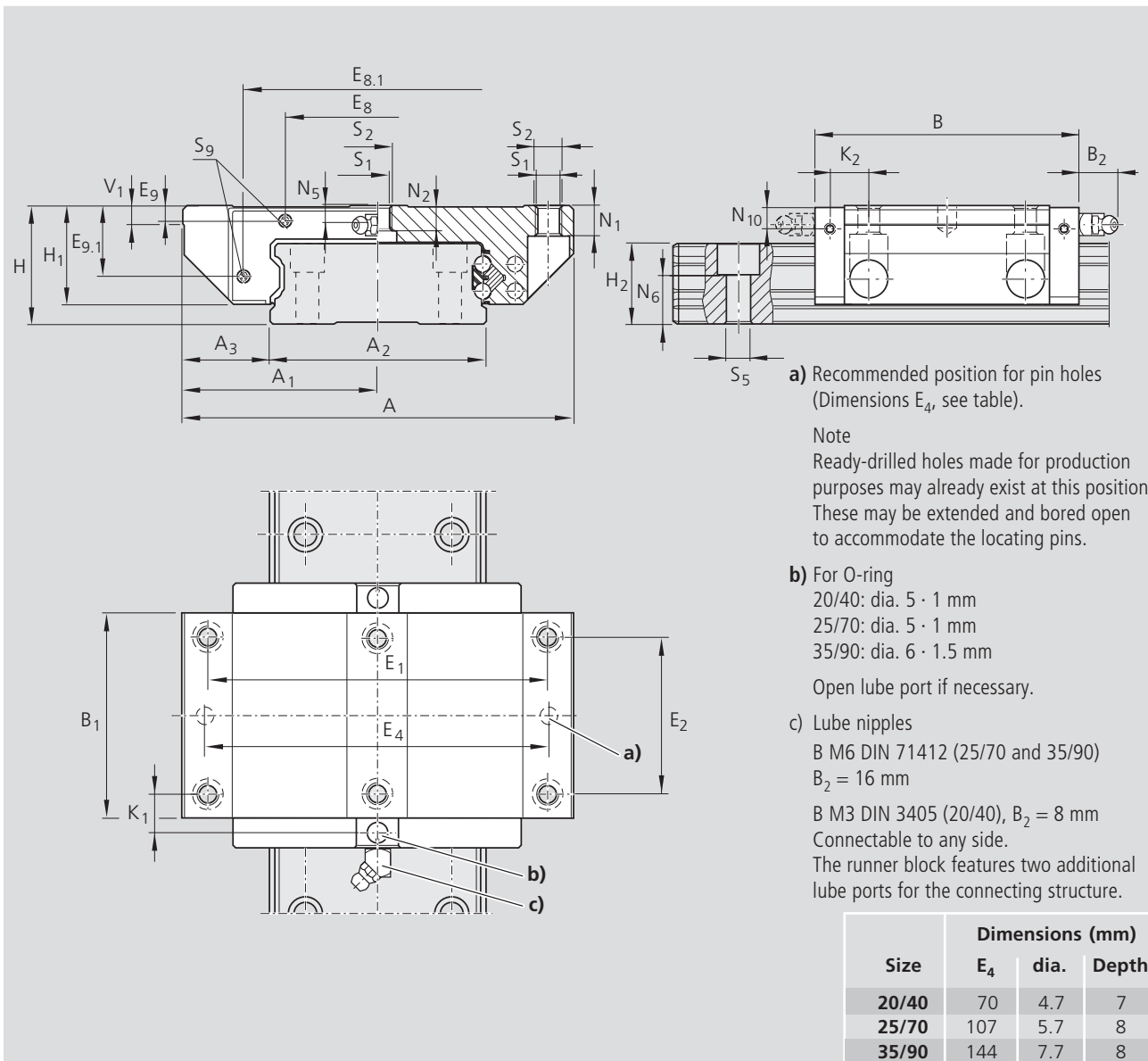

Size	Dimensions (mm)																		
	A	A ₁	A ₂	A ₃	B	B ₁	H	H ₁	H ₂	V ₁	E ₁	E ₂	E ₈	E _{8.1}	E ₉	E _{9.1}	N ₁	N ₂	N ₅
20/40	80	40	42	19.0	73	52.0	27	23.5	19.05	6.0	70	40	36.0	57.5	3.55	15.5	7.7	3.7	4.0
25/70	120	60	69	25.5	105	79.5	35	30.0	23.40	7.5	107	60	70.2	90.7	5.6	20.3	9.0	7.0	5.5
35/90	162	81	90	36.0	142	113.6	50	42.5	32.00	8.0	144	80	79.0	116.0	6.8	29.9	14.0	12.0	9.0

Size	Dimensions (mm)							Mass (kg)	Load capacities (N)		Moments (Nm)			
	$N_6^{\pm 0.5}$	N_{10}	S ₁	S ₂	K ₁	K ₂	S ₉		C dyn.	C ₀ stat.	M_t dyn.	M_{t0} stat.	M_L dyn.	M_{L0} stat.
	20/40	13.2	5.5	5.4	M6	10.6	11.0		M2.5-3.5 deep	0.45	15 600	24 100	370	640
25/70	14.4	8.0	6.4	M8	15.4	16.3	M3-5 deep	1.70	30 400	45 500	1 130	1 690	345	510
35/90	20.5	9.0	8.4	M10	22.8	24.8	M3-5 deep	3.70	58 200	86 300	2 880	4 270	920	1 370

Wide Guide Rails

Guide Rail R1675

Wide, for mounting from above

- Plastic mounting hole plugs are supplied along with the rail.
Reordering data: see table inset on right for part numbers.
- For special applications:
Guide rails for steel mounting hole plugs,
Part numbers: **R1676 .5. ..**
(Not for size 20/40)

Steel mounting hole plugs to be ordered separately.

A mounting jig with instruction leaflet is available for mounting steel mounting hole plugs.

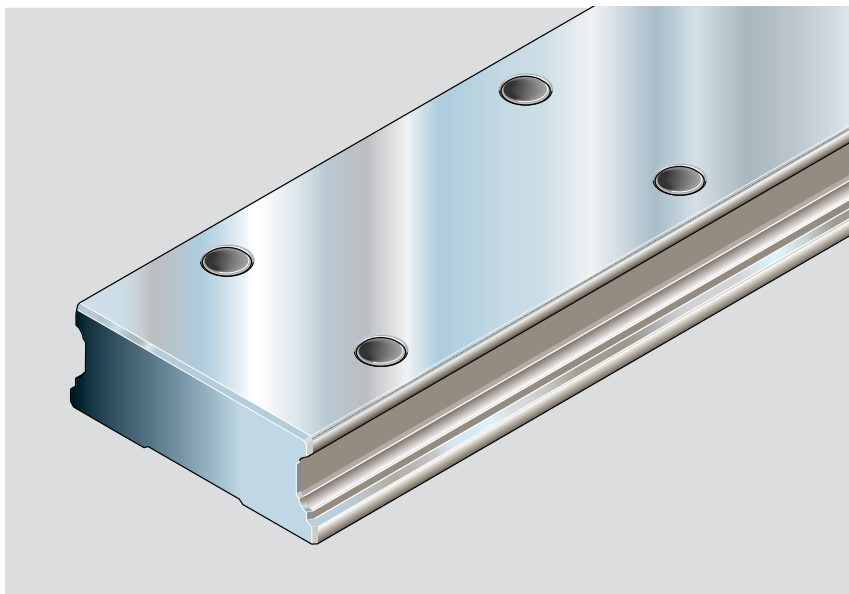

Special versions

Guide rails in accuracy classH are available as:

- Resist CR (matt silver)
Part number **R1673.03.4.**

Assembly Note

A mounting jig with assembly instructions is available for installing steel end caps.

Size	Part numbers Mounting jig
25/70	R1619 210 40
35/90	R1619 310 40

Part numbers and rail lengths

ize	Accuracy class	Guide Rail		Spacing T (mm)	Recommended rail length Number of holes n _B / Rail length L (mm) per row
		One-piece Part number, Rail length L (mm)	Composite Part number, Number of sections Rail length L (mm)		
20/40	N	R1675 804 31,....	R1675 804 3,....	60	From 2/ 116 to 64/ 3836 per formula L = n_B · T – 4
	H	R1675 803 31,....	R1675 803 3,....		
	P	R1675 802 31,....	R1675 802 3,....		
25/70	N	R1675 204 31,....	R1675 204 3,....	80	From 2/ 156 to 48/ 3836 per formula L = n_B · T – 4
	H	R1675 203 31,....	R1675 203 3,....		
	P	R1675 202 31,....	R1675 202 3,....		
35/90	N	R1675 304 31,....	R1675 304 3,....		
	H	R1675 303 31,....	R1675 303 3,....		
	P	R1675 302 31,....	R1675 302 3,....		

Mounting hole plugs

Size	Plastic mounting hole plugs
	Part numbers
20/40	R1605 100 80
25/70	R1605 200 80
35/90	R1605 300 80

Size	Steel mounting hole plugs
	Part numbers
25/70	R1606 200 75
35/90	R1606 300 75

Ordering guide rails at recommended lengths

The following examples are applicable to all guide rails.

Recommended and standard guide rail lengths have preferable delivery times (normally in warehouse stock).

From desired length to preferred length

$$L = \left(\frac{\text{desired length } L}{\text{division } T} \right)^* \cdot T - 4 \text{ mm}$$

* Rounded up to whole numbers

Example:

$$L = \left(\frac{1660 \text{ mm}}{80 \text{ mm}} \right) \cdot 80 \text{ mm} - 4 \text{ mm}$$

$$L = 21 \cdot 80 \text{ mm} - 4 \text{ mm}$$

$$L = 1676 \text{ mm}$$

Intermediate lengths

Example 1 (up to L_{max}):

- Rail guide size 35/90,
- Accuracy class H,
- Calculated rail length 1676 mm, ($20 \cdot T$, preferred dimension $T_{15} = 38 \text{ mm}$;
- Number of holes $n_B = 21$)

Ordering data:

Part number, length (mm)

$T_1 / n_T \cdot T / T_1$ (mm)

R1675 303 31, 1676 mm

38 / 20 · 80 / 38 mm

Note on examples:

- If the preferred dimension T_{15} cannot be used:
 - Select an end space T_1 between T_{15} and T_{1min} .
 - Do not go below minimum spacing of T_{1min} !
- T_1, T_{1min}, T_{15} are the same at either end of the guide rail

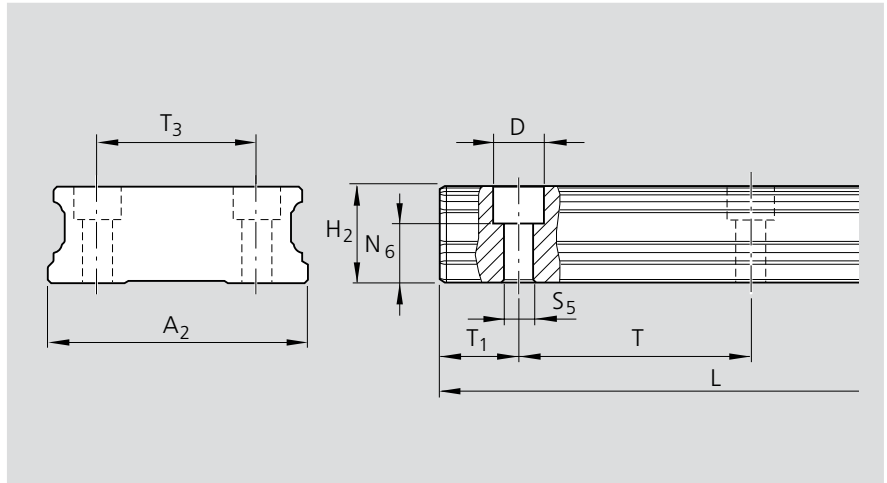

Size	Dimension (mm)										Mass (kg/m)
	A ₂	H ₂	N ₆ ^{±0.5}	D	S ₅	T ₁₅ ^{+0.5/-1.0}	T _{1min}	T	T ₃	L _{max}	
20/40	42	19.05	13.2	7.4	4.4	28	10	60	24	4 000	5.3
25/70	69	23.40	14.4	11.0	7.0	38	10	80	40	4 000	11.6
35/90	90	32.00	20.5	15.0	9.0	38	12	80	60	4 000	21.0

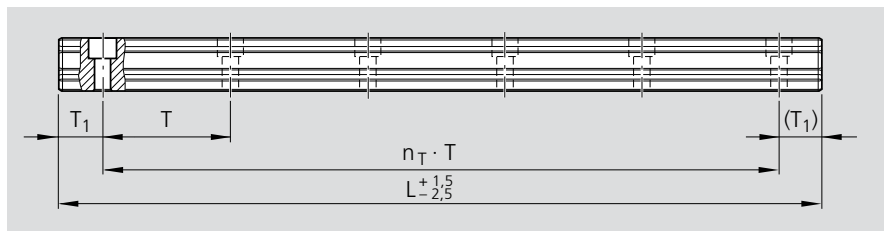

$$L = n_B \cdot T - 4$$

or

$$L = n_T \cdot T + 2 \cdot T_{15}$$

L = rail length (mm)

T = hole spacing*) (mm)

T₁₅ = preferred dimension*) (mm)

n_B = number of holes per row

n_T = number of spaces

*) see tables for values

Example 2 (over L_{max}):

- Guide rail size 35/90
- Accuracy class H,
- Rail length 5036 mm, 2 sections ($62 \cdot T$, preferred dimension $T_{15} = 38 \text{ mm}$;
- Number of holes $n_B = 63$)

Ordering data:

Part numbers and number of sections, length (mm)

$T_1 / n_T \cdot T / T_1$ (mm)

R1675 303 32, 5036 mm

38 / 62 · 80 / 38 mm

For rails longer than L_{max} , matched sections are put together at the factory.

Wide Guide Rails

Guide rail R1677

Wide, for mounting from below

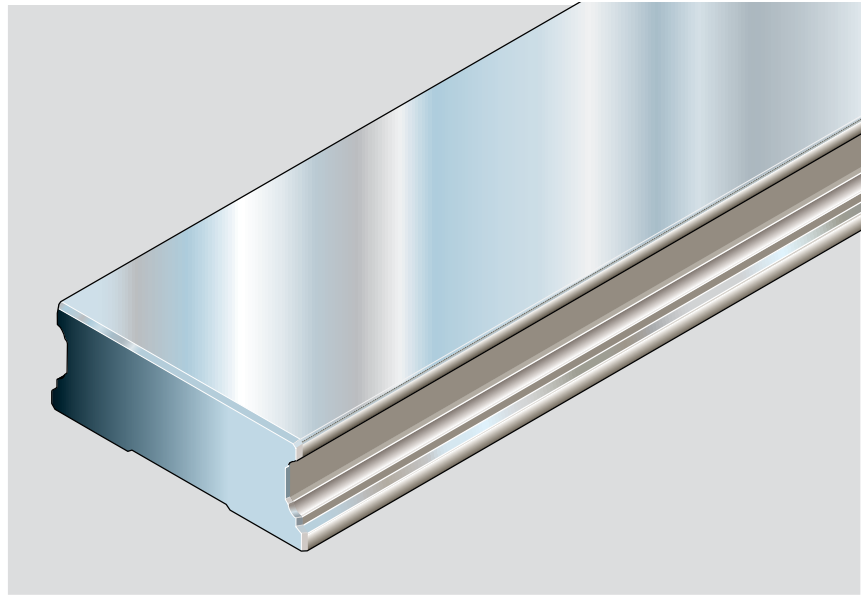

Part numbers and rail lengths

Size	Accuracy class	Guide Rail		Spacing T (mm)	Recommended rail length Number of holes n_B / Rail length L (mm) per row
		One-piece Part number, Rail length L (mm)	Composite Part number, Number of sections Rail length L (mm)		
20/40	N	R1677 804 31,....	R1677 804 3,....	60	From 2/ 116 to 64/ 3836 per formula $L = n_B \cdot T - 4$
	H	R1677 803 31,....	R1677 803 3,....		
	P	R1677 802 31,....	R1677 802 3,....		
25/70	N	R1677 204 31,....	R1677 204 3,....	80	From 2/ 156 to 48/ 3836 per formula $L = n_B \cdot T - 4$
	H	R1677 203 31,....	R1677 203 3,....		
	P	R1677 202 31,....	R1677 202 3,....		
35/90	N	R1677 304 31,....	R1677 304 3,....	80	From 2/ 156 to 48/ 3836 per formula $L = n_B \cdot T - 4$
	H	R1677 303 31,....	R1677 303 3,....		
	P	R1677 302 31,....	R1677 302 3,....		

Ordering guide rails at recommended lengths

The following examples are applicable to all guide rails.

Recommended and standard guide rail lengths have preferable delivery times (normally in warehouse stock).

From desired length to preferred length

$$L = \left(\frac{\text{desired length } L}{\text{division } T} \right)^* \cdot T - 4 \text{ mm}$$

* Rounded up to whole numbers

Example:

$$L = \left(\frac{1660 \text{ mm}}{80 \text{ mm}} \right) \cdot 80 \text{ mm} - 4 \text{ mm}$$

$$L = 21 \cdot 80 \text{ mm} - 4 \text{ mm}$$

$$L = 1676 \text{ mm}$$

Intermediate lengths

Example 1 (up to L_{\max}):

- Rail guide size 35/90,
- Accuracy class H,
- Calculated rail length 1676 mm, ($20 \cdot T$, preferred dimension $T_{15} = 38$ mm; Number of holes $n_B = 21$)

Ordering data:

Part number, length (mm)

$T_1 / n_T \cdot T / T_1$ (mm)

R1675 303 31, 1676 mm

38 / 20 · 80 / 38 mm

Note on examples:

- If the preferred dimension T_{15} cannot be used:
 - Select an end space T_1 between T_{15} and $T_{1\min}$.
 - Do not go below minimum spacing of $T_{1\min}$!
- T_1 , $T_{1\min}$, T_{15} are the same at either end of the guide rail

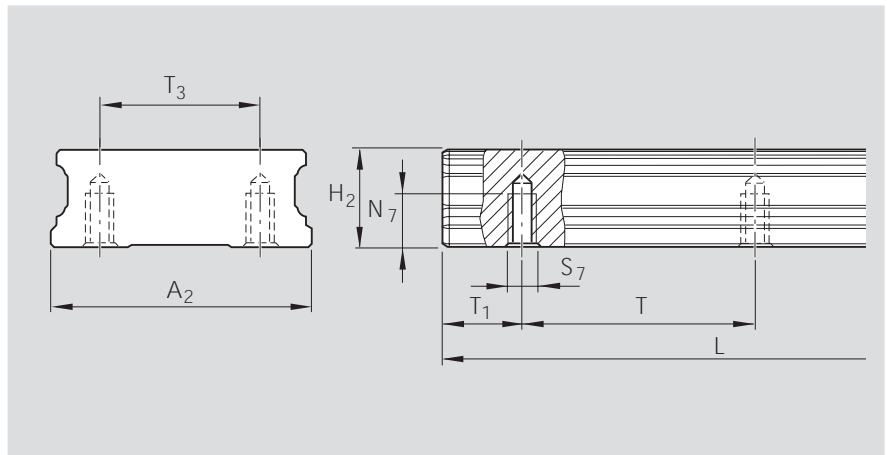

Size	Dimension (mm)									Mass (kg/m)
	A_2	H_2	N_7	S_7	$T_{15}^{+9.5}_{-1.0}$	$T_{1\min}$	T	T_3	L_{\max}	
20/40	42	19.05	7.5	M5	28	10	60	24	4 000	5.3
25/70	69	23.40	12.0	M6	38	10	80	40	4 000	11.6
35/90	90	32.00	15.0	M8	38	12	80	60	4 000	21.0

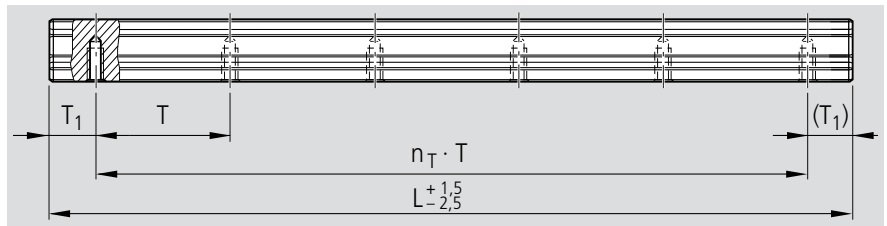

$$L = n_B \cdot T - 4$$

or

$$L = n_T \cdot T + 2 \cdot T_{15}$$

L = rail length (mm)
 T = hole spacing*) (mm)
 T_{15} = preferred dimension*) (mm)
 n_B = number of holes per row
 n_T = number of spaces
 *) see tables for values

Example 2 (over L_{\max}):

- Guide rail size 35/90
- Accuracy class H,
- Rail length 5036 mm, 2 sections ($62 \cdot T$, preferred dimension $T_{15} = 38$ mm; Number of holes $n_B = 63$)

Ordering data:

Part numbers and number of sections, length (mm)

$T_1 / n_T \cdot T / T_1$ (mm)

R1677 303 32, 5036 mm

38 / 62 · 80 / 38 mm

For rails longer than L_{\max} , matched sections are put together at the factory.

Accessories for Wide Ball Rail Systems

Wide lubrication plate, G 1/8

– Material: aluminum

Mounting instructions:

The parts required to mount the optional attachments on the runner block are supplied together with the standard parts.

The runner block lube nipple can be used.

For mounting details, see "Mounting Instructions for Ball Rail Systems".

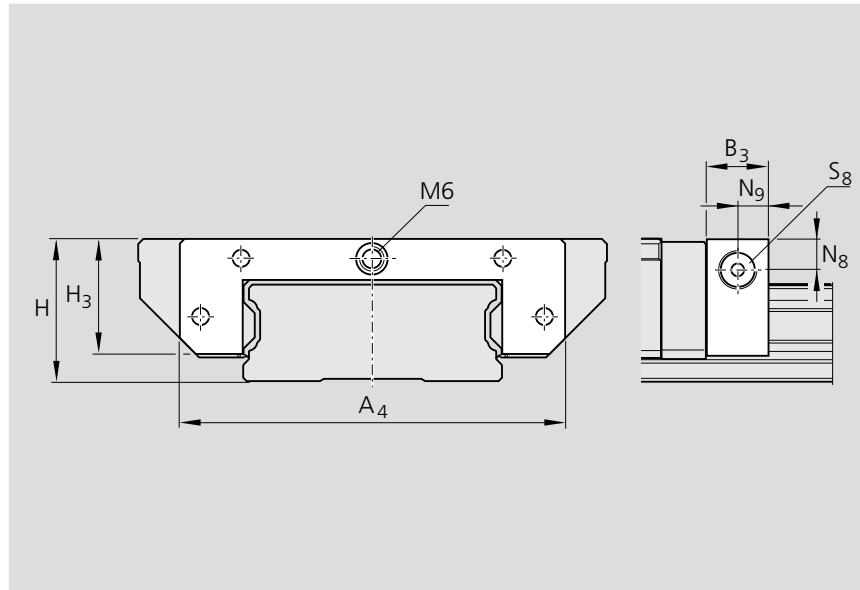

Size	Part numbers	Dimensions (mm)							S ₈	Mass (g)
		A ₄	B ₃	H	H ₃	N ₈	N ₉			
25/70	R1670 211 30	101	16	35	29	7.7	8	G 1/8 - 8 deep	65	
35/90	R1670 311 30	129	16	50	41	8.3	8	G 1/8 - 8 deep	120	

Wide scraper plate

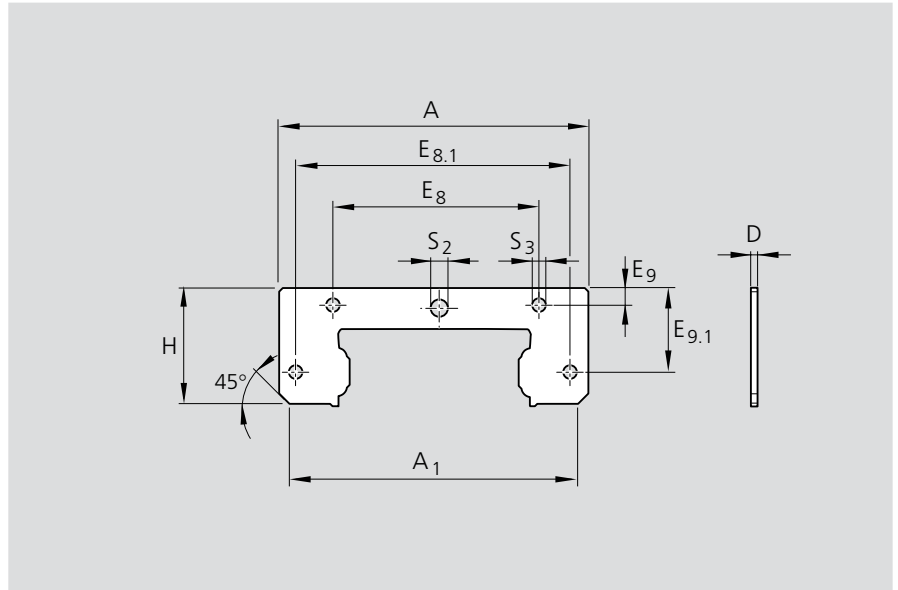

Size	Part numbers	Dimensions (mm)										Mass (g)
		A	A ₁	H	E ₈	E _{8.1}	E ₉	E _{9.1}	S ₂	S ₃	D	
20/40	R1670 810 00	64.5	61.5	22.8	36.0	57.5	3.0	15.0	∅4	∅4	1.0	10
25/70	R1670 210 00	101.0	92.7	28.6	70.2	90.7	5.1	19.7	∅7	∅4	1.0	14
35/90	R1670 310 00	129.0	124.2	40.8	79.0	116	5.6	28.7	∅7	∅4	1.0	25

Two-piece front seal

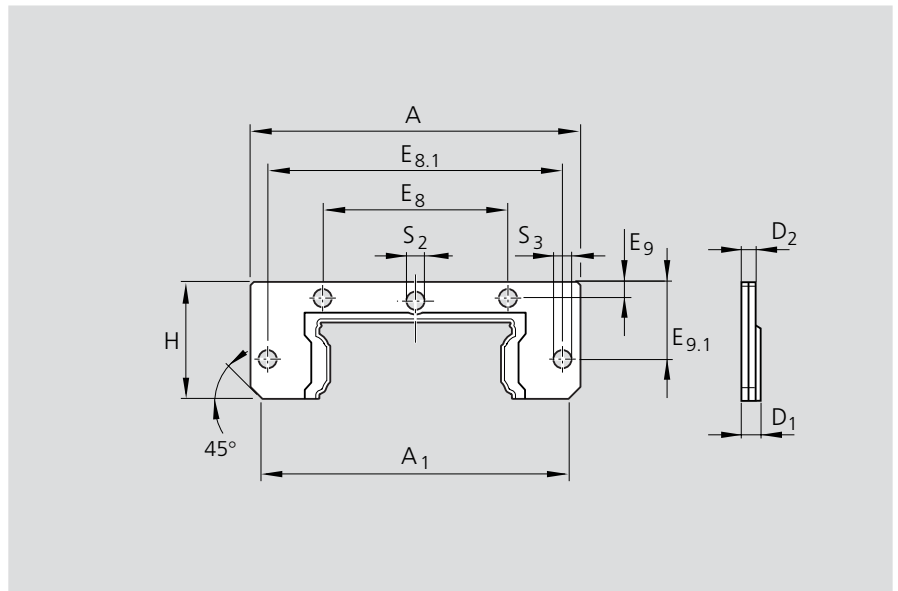

Size	Part numbers	Dimensions (mm)										Mass (g)	
		A	A ₁	H	E ₈	E _{8.1}	E ₉	E _{9.1}	S ₂	S ₃	D		D ₂
20/40	R1619 822 20	64.5	61.5	22.8	36.0	57.5	3.05	15.0	∅ 3.5	∅ 3.5	3.3	2.5	7.5
25/70	R1619 222 20	101.0	96.6	28.6	70.2	90.7	5.00	19.7	∅ 7	∅ 4	3.3	2.5	14.5
35/90	R1619 322 20	128.6	124.2	41.0	79.0	116.0	5.80	28.9	∅7	∅ 4	4.5	3.3	40.0

Accessories for Wide Ball Rail Systems

Wide bellows

– Material: bellows-type protective cover of polyurethane-coated polyester fabric
The runner block lube nipple can be used.

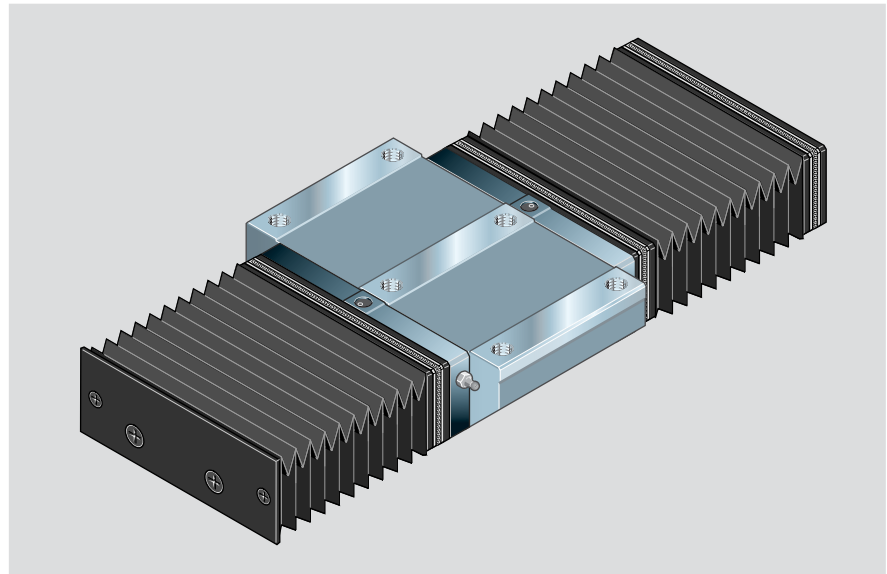

Part numbers, bellows

Ordering example for bellows

Size 35/90, Type 2,
Number of folds: 36
1670-302-00, 36 folds

Size	Type 2		Type 4		Type 9	
	with mounting frame and end plate	Number of folds	with 2 mounting frames	Number of folds	Bellows, loose supply (spare part)	Number of folds
20/40	R1670 802 00	...	R1670 804 00	..	R1670 809 00	...
25/70	R1670 202 00	...	R1670 204 00	...	R1670 209 00	...
35/90	R1670 302 00	...	R1670 304 00	...	R1670 309 00	...

Mounting instructions

The bellows are delivered preassembled ready for installation, complete with the screws required for attachment to the guide rail.

For type 2, two threads size M4-8 10 mm deep and countersunk 2 x 45° must be tapped in each end face of the rail. *

The runner block lube nipple can be used.

* with size 20/40, only one thread in the rail center

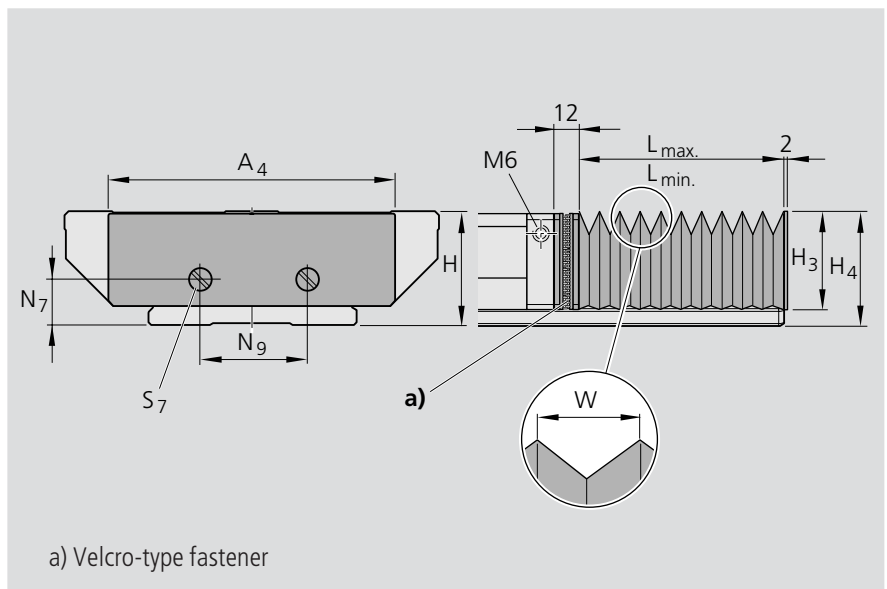

Dimensions: bellows

Size	Dimensions (mm)								Factor U
	A ₄	H	H ₃	H ₄	N ₇	N ₉	S ₇	W	
20/40	73	27	31	35	11.5	–	M4	19.9	1.12
25/70	101	35	29	35	14.0	26	M4	12.9	1.25
35/90	128	50	42	49	21.5	40	M4	19.9	1.18

Accessories for Wide Ball Rail Systems

Bellows design formulas

$$L_{\max} = (\text{Stroke} + 30) \cdot U$$

$$L_{\min} = L_{\max} - \text{Stroke}$$

$$\text{No. of folds} = \frac{L_{\max}}{W} + 2$$

L_{\max} = Bellows extended

L_{\min} = Bellows compressed

Stroke = Stroke (mm)

U = Calculation factor

W = Maximum extension (mm)

Rail length formula

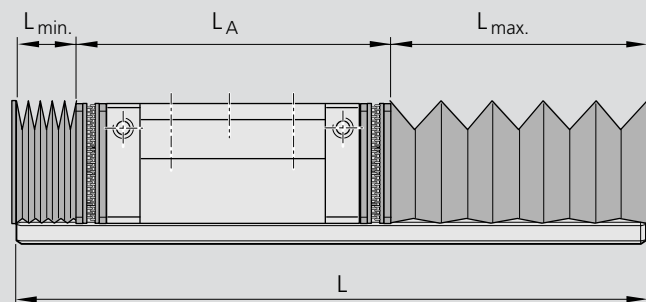

$$L = L_{\min} + L_{\max} + L_A$$

L = Rail length (mm)

Mounting Accessories

For details of how to mount accessories such as the lubrication plate, bellows etc, see "Mounting Instructions for Ball Rail Systems" RE 82 270.

Overview of Accessories and Allocation

General Accessories – for Runner Blocks

Lube nipple



Lubrication connections

- Reduction pieces
- Swiveling screw fittings
- Plug-in connectors (NEW)
- Extensions

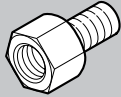

Plastic hose for lubrication connection

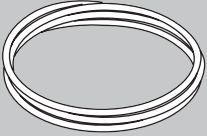
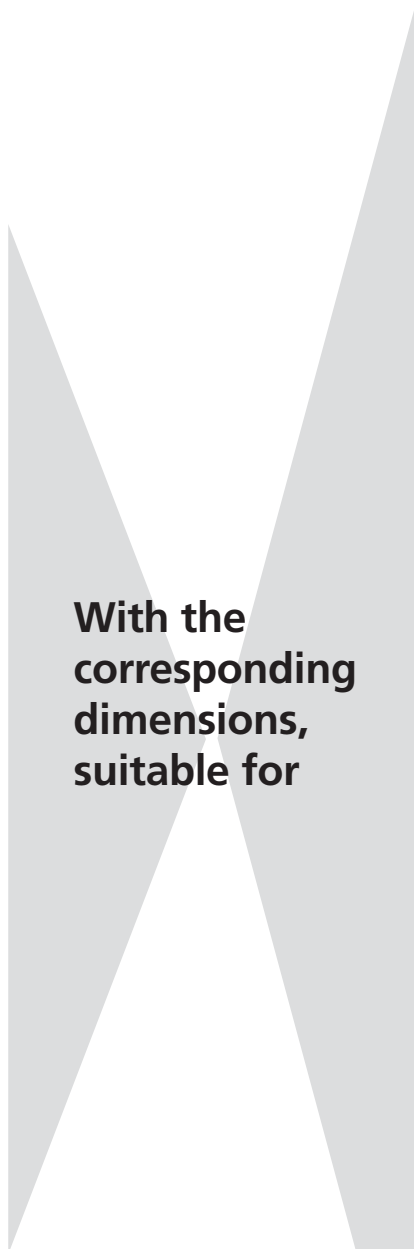
With the corresponding dimensions, suitable for

Mounting Accessories

Mounting accessories, see Mounting Instructions for Ball Rail Systems RE 82 270

General Accessories – for Guide Rails

Wedge-profile retaining strip

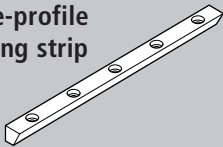

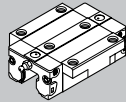

suitable for

Standard Runner Blocks

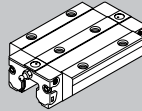

Runner Block
Flange Standard FNS
R1651
R2001
R1631



Runner Block
Flange long FLS
R1653
R2002

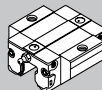

Runner Block
Flange short FKS
R1665
R1661
R2000

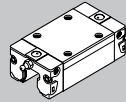

Runner Block
Slimline Standard SNS
R1622
R2011
R1632

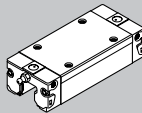

Runner Block
Slimline Long SLS
R1623
R2012

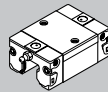

Runner Block
Slimline Short SKS
R1666
R1662
R2010

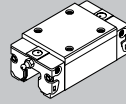

Runner Block
Slimline High SNH
R1621

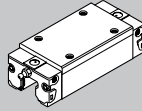

Runner Block
Slimline Long High SLH
R1624

Wide Runner Blocks

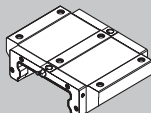

Runner Block
Wide Low Profile BNN
R1671

all guide rails

General Accessories – for Runner Blocks

Funnel-type lube nipple

Part number
R3417 004 09

Part number
R3417 029 09
Resist NR II: R3417 032 09

Part number
R3417 005 01

Hydraulic-type lube nipple

Part number
R3417 007 02

Part number
R3417 008 02
Resist NR II: R3417 013 02

Reducing adapters

Part number
R3455 030 34

Part number
R3455 030 37

Part number
R3455 030 38

General Accessories – for Runner Blocks

Extension

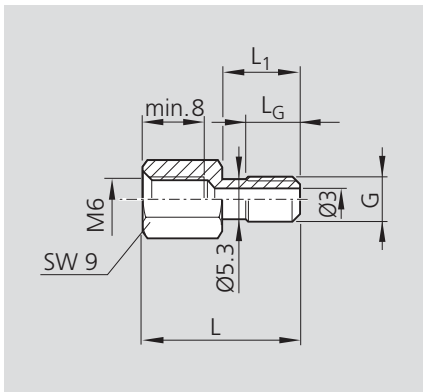

Part numbers	Dimensions (mm)			
	L	L1	G	LG
R3455 030 69	21.0	10.5	M6	7.0
R3455 030 87	25.0	14.5	M6	8.0
R3455 030 85	26.5	16.0	M6	7.0

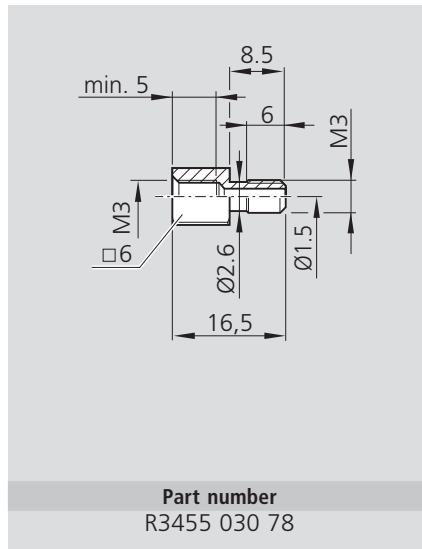

Part number
R3455 030 78

Swivel fitting

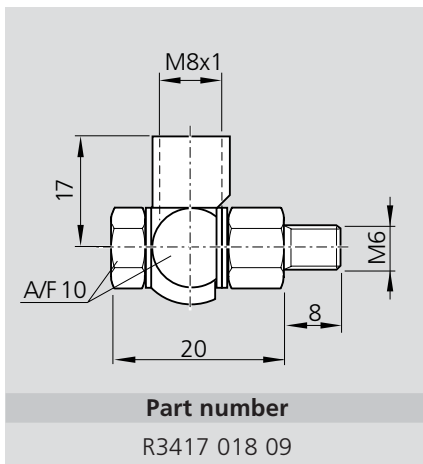

Part number
R3417 018 09

Push in fittings for plastic tubing for runner blocks without accessories

Straight connector

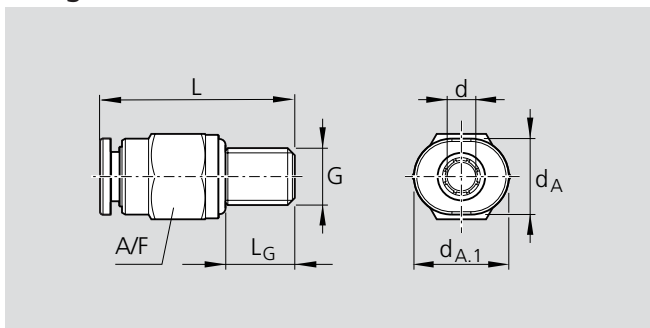

Part numbers	Dimensions (mm)						
	dA	dA.1	d	L	SW	G	LG
R3417 033 09	6.0	7.0	3	15.5	6*	M3	5.0
R3417 034 09	8.0	9.0	3	18.0	8	M5	5.0
R3417 035 09	8.5	10.0	4	20.5	9	M6	8.0
R3417 036 09	10.0	12.0	6	21.5	10	M6	8.0

* Maximum tightening torque: 0.5 Nm

General Accessories – for Runner Blocks

Angle coupling, rotating¹⁾

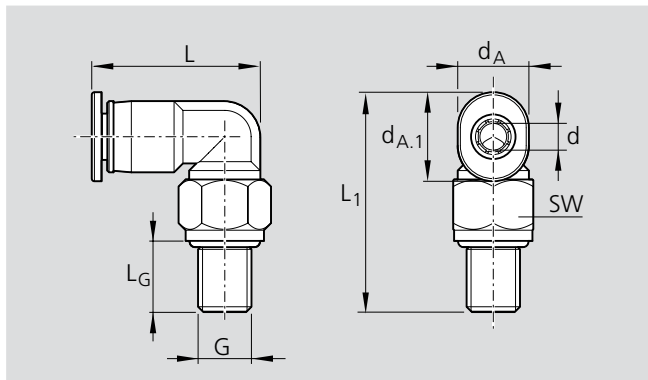

Part numbers	Dimensions (mm)							
	dA	dA.1	d	L	L1	SW	G	LG
R3417 037 09	6.0	7	3	13.7	18.0	6 ²⁾	M3	5.0
R3417 038 09	8.0	10	4	19.5	24.7	9	M6	8.0
R3417 039 09	10.5	12	6	20.0	25.0	9	M6	8.0

¹⁾ Maximum lubricant pressure: 30 bar

²⁾ Maximum tightening torque: 0.5 Nm

Plastic hose, ø 3 mm



Part numbers	ø outside (mm)	ø inside (mm)	length (m)
R3499 287 00	3	1.7	50

O-Rings

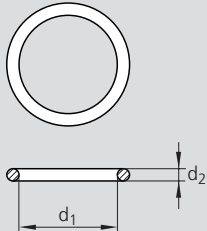
	O-Ring	
	Part numbers	d1 x d2 (mm)
	R3411 130 01	4 x 1.0
	R3411 131 01	5 x 1.0
	R3411 003 01	6 x 1.5

General Accessories – for Guide Rails

Wedge profile for ball rail systems – Lateral retention

- Material: steel
- Version: gunmetal finish

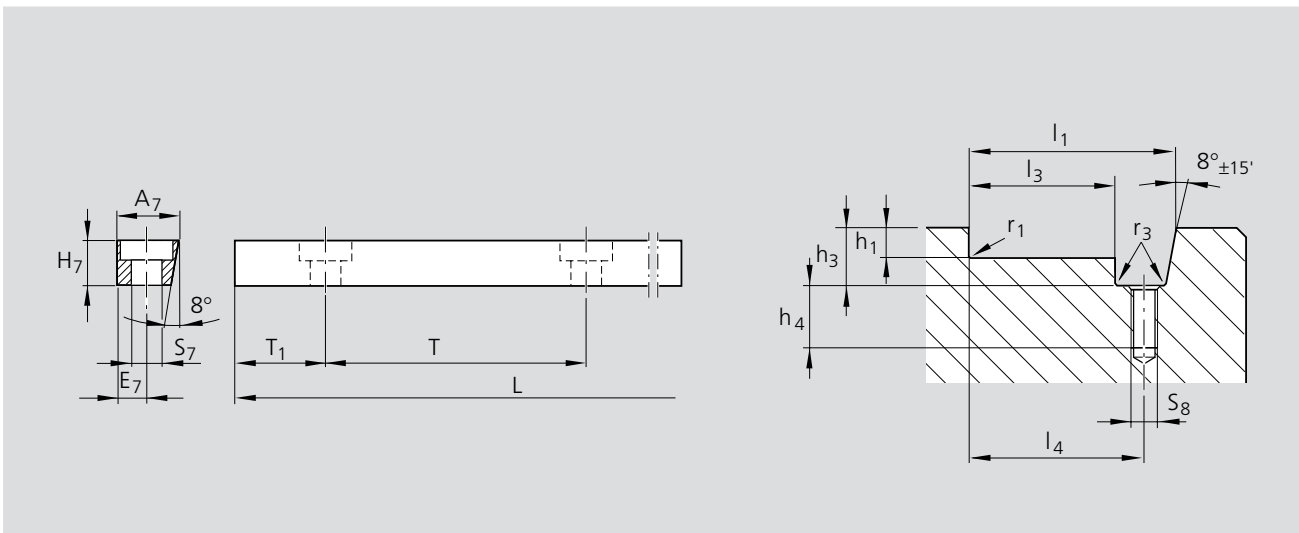
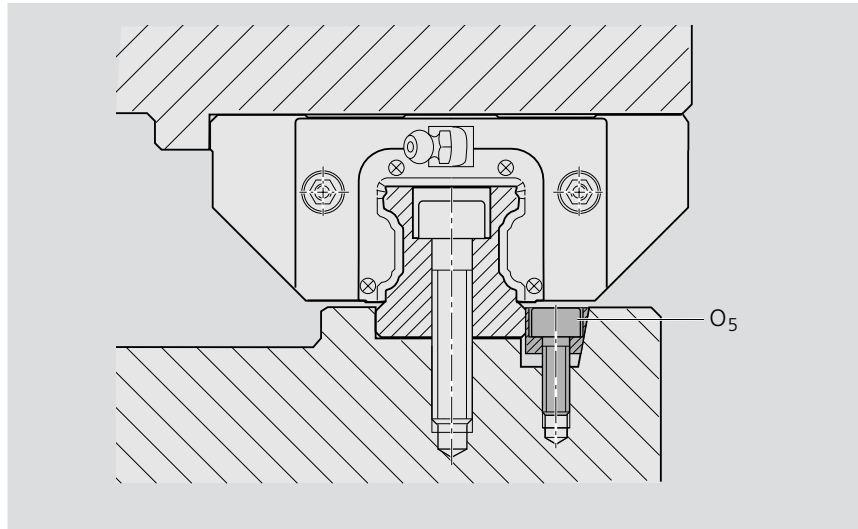

Part numbers and dimensions

Size	Part numbers	Wedge profile							Wedge profile groove									
		A ₇	E ₇	H ₇	S ₇	T	T ₁	L	O ₅	h ₁	h ₃	h ₄	l ₁	l ₃	l ₄	S ₈	r ₁	r ₃
									DIN 6912	-0.2	+1	+2	±0.05	-0.1	±0.1		max.	max.
15	R1619 200 01	12	6	10	6.0	60	28.5	957	M5x20	3.5	12.5	15	27	15	21	M5	0.4	0.5
20										4	12.5	15	32	20	26	M5	0.5	0.5
25										5	12.5	15	35	23	29	M5	0.8	0.5
30										5	12.5	15	40	28	34	M5	0.8	0.5
35										6	12.5	15	46	34	40	M5	0.8	0.5
45	R1619 400 01	19	9	16	9.0	105	51.0	942	M8x25	8	19.0	16	64	45	54	M8	0.8	0.5
55										10	19.0	16	72	53	62	M8	1.2	0.5
65										10	19.0	16	82	63	72	M8	1.2	0.5

General Mounting Instructions

General Notes

The following notes relating to mounting apply to all ball rail systems.

However, different specifications exist with regard to the parallelism of the guide rails and to mounting the runner blocks with locating pins.

This information is provided separately alongside the descriptions of the individual types. Rexroth Ball Rail Systems are high-grade quality products.

Particular care must be taken during transportation and subsequent mounting.

All steel components are protected with anti-corrosion oil. Preservative substances do not need to be removed provided the recommended lubricants are used.

⚠ During overhead assembly, the runner block may be damaged causing loss or breakage of balls. Secure the runner block to prevent it from falling!

Mounting examples

Guide rails:

☞ Each guide rail has ground reference surfaces on both sides.

Possibilities for side fixing:

- 1 Reference edges
- 2 Retaining strips
- 3 Wedge-profile retaining strip

Note

Guide rails without side fixing have to be aligned straight and parallel when mounting, preferably to an auxiliary strip. (recommended limits for side load if no additional lateral retention is provided, see individual types)

Runner Blocks:

☞ Each runner block has a ground reference edge on one side (→ Dimension V_1 in the dimension drawings).

Possibilities for additional fixing:

- 1 Reference edges
- 2 Retaining strips
- 4 Locating pins

Note

After mounting, it should be possible to move the runner block easily.

Mounting Instructions

For detailed mounting steps, see "Mounting Instructions for Ball Rail Systems" RDEFI 82 270.

Mounting with fixation of both guide rails and runner blocks

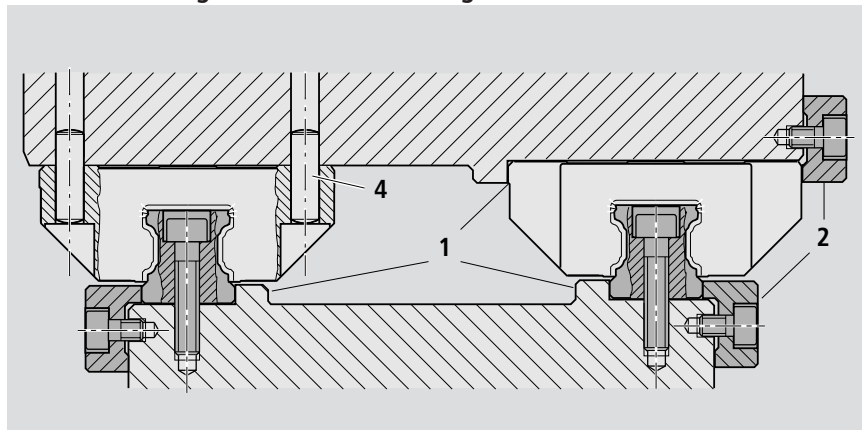

Mounting with fixation of a guide rail and runner block

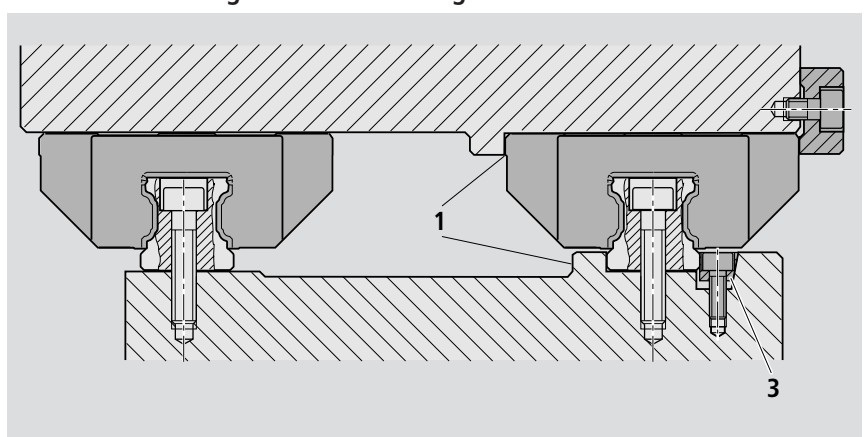

Mounting Instructions

Reference edges, corner radii, mounting screw sizes and tightening torque

Runner Blocks Fxx

- Flange type

Guide Rails

- left:
- For mounting from above R1605, R1645, R2045
- right:
- For mounting from below R1607, R1647, R2047

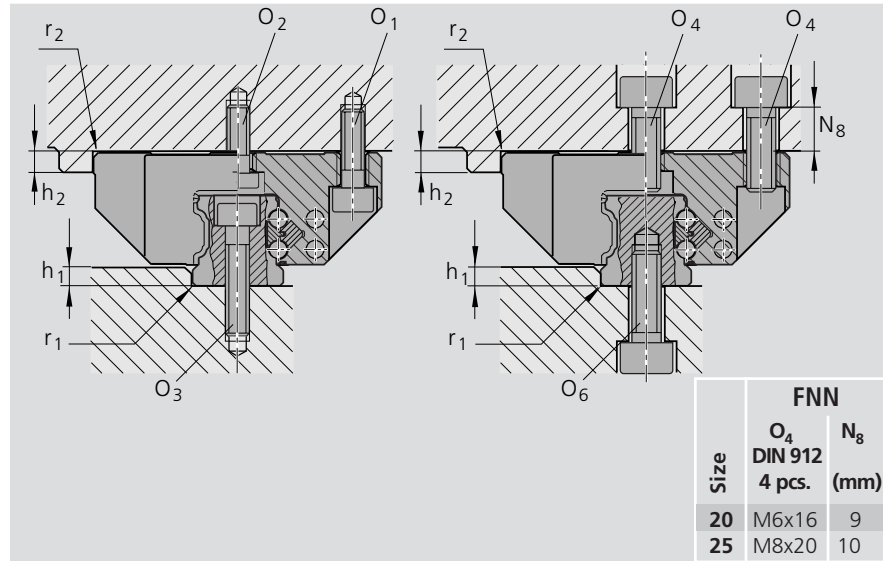

Runner Blocks Sxx

- Slimline

Guide rail

- For mounting from above R1605, R1645, R2045

Note

The indicated combinations represent examples. It is basically possible to combine any runner block with all the offered guide rail types.

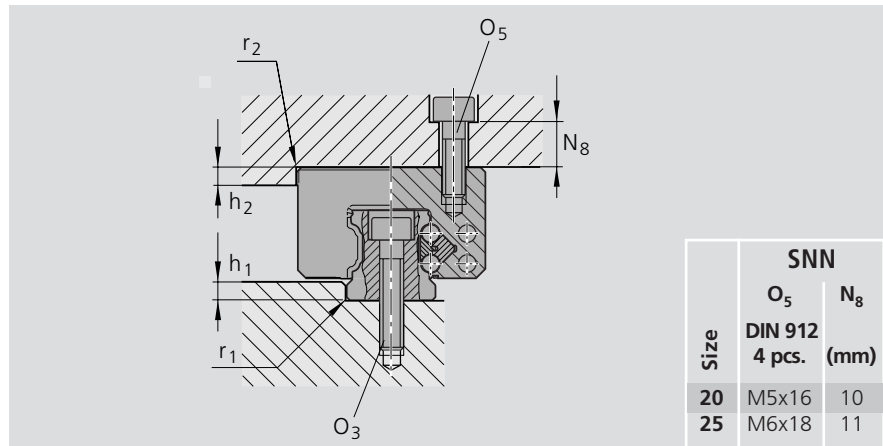

Dimensions and recommended limits for side load if no additional lateral retention is provided

- When mounting the runner block from above using only 4 O₄ screws:
 - Permissible side force 1/3 lower
 - Lower rigidity
- For runner block mounting with 6 screws:
 - Tighten screws with torque of strength class 8.8.
- When mounting with 2 O₂ screws and 4 O₁ screws

Size	h ₁	r ₁	h ₂	r ₂	O ₁	O ₂ ²⁾	O ₄ ¹⁾²⁾	O ₅	O ₃	O ₆	N ₈ (mm)	
	min. (mm)	max. (mm)	max. (mm)	max. (mm)	DIN 912 4 pcs.	DIN 6912 2 pcs.	DIN 912 6 pcs.	DIN 912 4 pcs.	DIN 912	DIN 912		
15	2.5	3.5	0.4	4	0.6	M4x12	M4x10	M5x12	M4x12	M4x20	M5x12	6
20	2.5	4.0	0.6	5	0.6	M5x16	M5x12	M6x16	M5x16	M5x25	M6x16	9
25	3.0	5.0	0.8	5	0.8	M6x20	M6x16	M8x20	M6x18	M6x30	M6x20	10
30	3.0	5.0	0.8	6	0.8	M8x25	M8x16	M10x20	M8x20	M8x30	M8x20	10
35	3.5	6.0	0.8	6	0.8	M8x25	M8x20	M10x25	M8x25	M8x35	M8x25	13
45	4.5	8.0	0.8	8	0.8	M10x30	M10x25	M12x30	M10x30	M12x45	M12x30	14
55	7.0	10.0	1.2	10	1.0	M12x40	M12x30	M14x40	M12x35	M14x50	M14x40	20
65	7.0	10.0	1.2	14	1.0	M14x45	M14x35	M16x45	M16x40	M16x60	M16x45	22

Runner Blocks FNS, SNS, SNN, SNH, FNN

Screw strength class	Runner blocks			Guide rails		
8.8	0.11 C	0.15 C ³⁾	0.23 C	0.11 C	0.06 C	0.06 C
12.9	0.18 C	0.22 C ³⁾	0.35 C	0.18 C	0.10 C	0.10 C
8.8	0.08 C	0.13 C ³⁾	0.18 C	0.08 C	0.04 C	0.04 C
12.9	0.14 C	0.18 C ³⁾	0.26 C	0.14 C	0.07 C	0.07 C

Runner Blocks FLS, SLS, SLH

	M4	M5	M6	M8	M10	M12	M14	M16
8.8	2.7	5.5	9.5	23	46	80	125	195
12.9	4.6	9.5	16	39	77	135	215	330

Tightening torque of the mounting screws

Mounting Instructions

Locating pins

If the recommended values for permissible side forces are exceeded (see table), the runner block must be additionally fixed by means of locating pins or reference edges.

Recommended dimensions for the pin holes are indicated in the drawings and table.

Possible pin types:

- Taper pin (hardened) or
- Straight pin DIN ISO 8734

Note

Ready-drilled holes made for production reasons may exist at the recommended pin hole positions (dia. < S_{10}).

These may be extended and bored open to accommodate the locating pins.

If the locating pins have to be driven in at another point (e.g. when the lube port is central), dimension E_2 must not be exceeded in the longitudinal direction (for dimension E_2 , see the tables for the individual types).

Observe dimensions E_1 and E_4 !

Only prepare the pin holes after the installation is complete (see also "General Mounting Instructions").

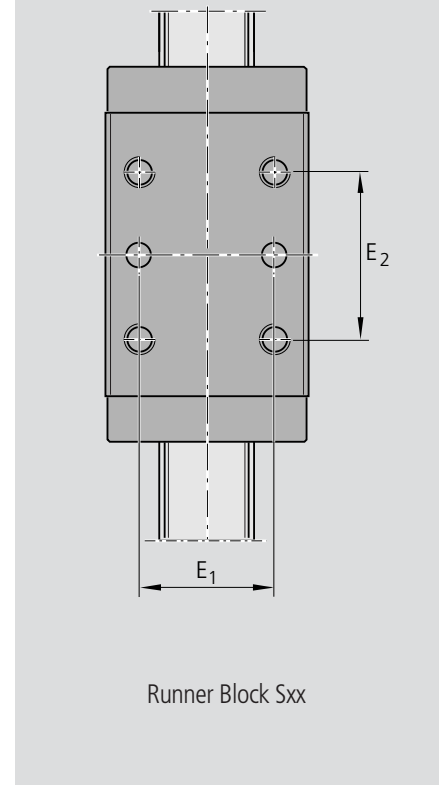
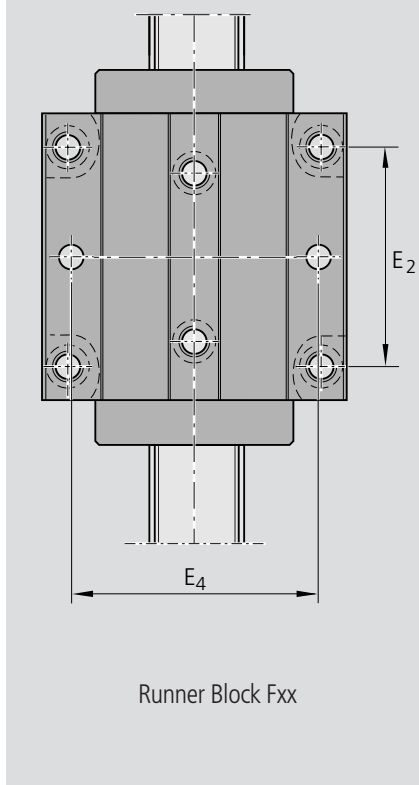
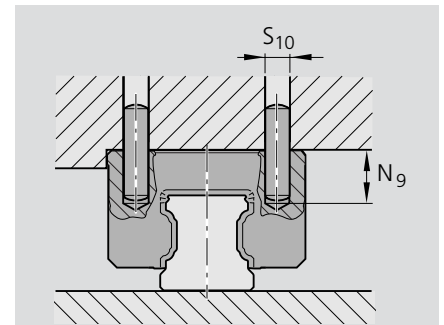
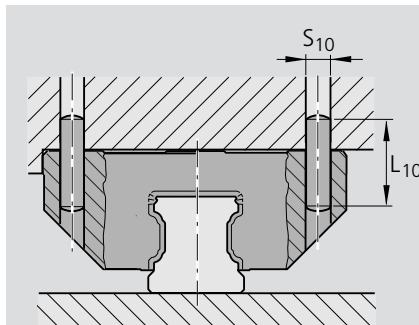

Size	Dimensions (mm)						
	Taper pin (hardened) Straight pin (DIN 6325)					R1693 R1694	
	S_{10}	L_{10}	E_1	E_4	N_9 (max)	E_4	N_9 (max)
15	4	18	26	38	6.0	-	-
20	5	24	32	53	7.5	49	6.5
25	6	32	35	55	9.0	60	7.0
30	8	36	40	70	12.0	-	-
35	8	40	50	80	13.0	-	-
45	10	50	60	98	18.0	-	-
55	12	60	75	114	19.0	-	-
65	14	60	76	140	22.0	-	-

Mounting Instructions

Reference edges, corner radii, mounting screw sizes and tightening torque

Runner Blocks FKx

– Flange Short

Guide Rails

- left:
 – For mounting from above R1605
- right:
 – For mounting from below R1607

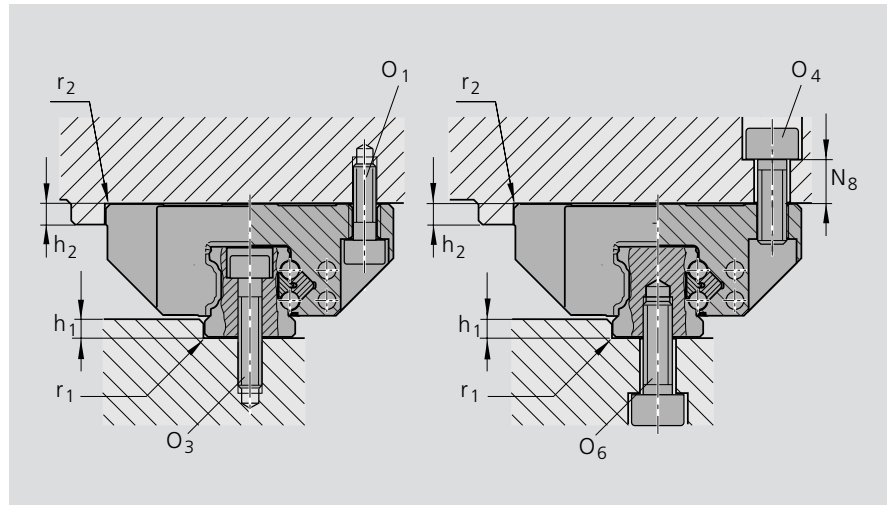

Runner Blocks SKx

– Slimline Short

Guide Rails

– For mounting from above R1605

Note

The indicated combinations represent examples. It is basically possible to combine any runner block with all the offered guide rail types.

Screw mounting of runner blocks using two screws is fully sufficient up to maximum load.

(See maximum permissible force and moment loads indicated under the individual types.)

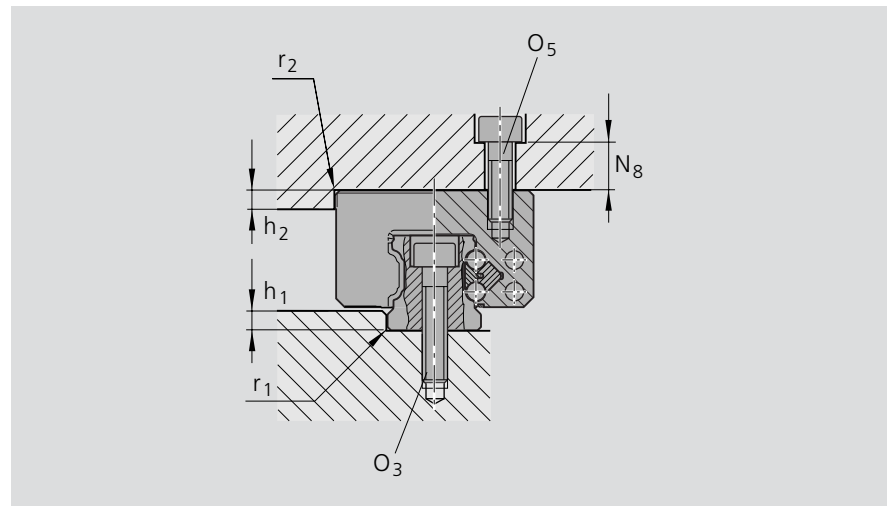

Dimensions and recommended limits for side load if no additional lateral retention is provided (Runner Blocks FKN, SKN, FKS, SKS)

Size	h ₁		r ₁	h ₂	r ₂	O ₁	O ₄	O ₅	O ₃	O ₆	N ₈
	min. (mm)	max. (mm)	max. (mm)	(mm)	max. (mm)	DIN 912 2 pcs.	DIN 912 2 pcs.	DIN 912 2 pcs.	DIN 912 (rail)	DIN 912 (rail)	(mm)
15	2.5	3.5	0.4	4	0.6	M4x12	M5x12	M4x12	M4x20	M5x12	6
20	2.5	4.0	0.6	5	0.6	M5x16	M6x16	M5x16	M5x25	M6x16	9
25	3.0	5.0	0.8	5	0.8	M6x20	M8x20	M6x18	M6x30	M6x20	10
30	3.0	5.0	0.8	6	0.8	M8x25	M10x20	M8x20	M8x30	M8x20	10
35	3.5	6.0	0.8	6	0.8	M8x25	M10x25	M8x25	M8x35	M8x25	13
Screw strength class						Runner blocks			Guide rails		
8.8						0.08 C	0.12 C	0.08 C	0.09 C	0.09 C	
12.9						0.13 C	0.21 C	0.13 C	0.15 C	0.15 C	

Tightening torque of the mounting screws

Nm	Screw							
	M4	M5	M6	M8	M10	M12	M14	M16
8.8	2.7	5.5	9.5	23	46	80	125	195
12.9	4.6	9.5	16	39	77	135	215	330

Mounting Instructions

Locating pins

If the recommended values for permissible side forces are exceeded, the runner block must be additionally fixed by means of locating pins or reference edges.

Recommended dimensions for the pin holes are indicated in the drawings and table.

Possible pin types:

- Taper pin (hardened) or
- Straight pin DIN ISO 8734

Note

Ready-drilled holes made for production reasons may exist at the recommended pin hole positions (dia. < S_{10}).

These may be extended and bored open to accommodate the locating pins.

Only prepare the pin holes after the installation is complete (see also "General Mounting Instructions").

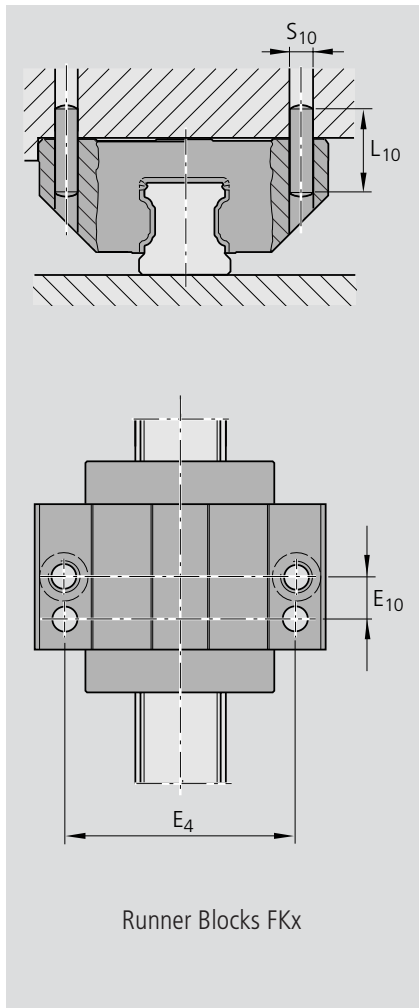

Runner Blocks FKx

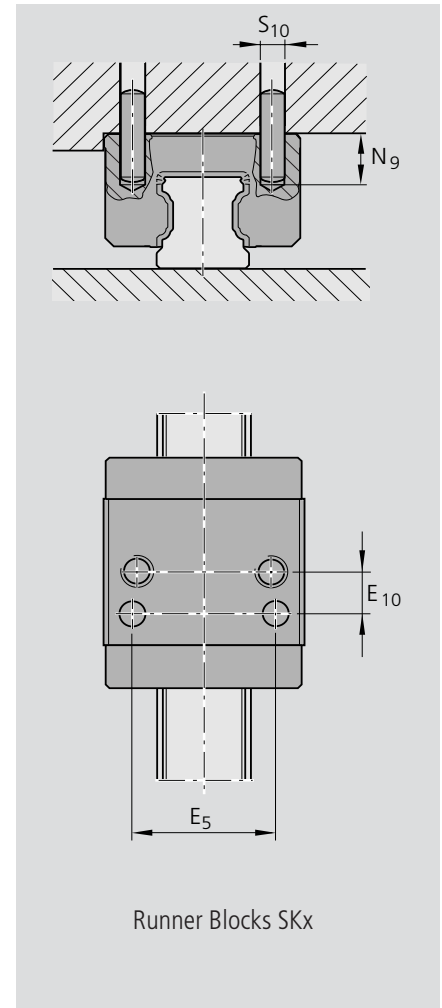

Runner Blocks SKx

Size	Dimensions (mm)						R1663 R1664	
	Taper pin (hardened) Straight pin (DIN 6325)		E_4	E_5	E_{10}	N_9 (max)	E_4	N_9 (max)
S_{10}	L_{10}							
15	4	18	38	26	9	3.0	-	-
20	5	24	53	32	10	3.5	49	2
25	6	32	55	35	11	7.0	60	5
30	8	36	70	40	14	10.0	-	-
35	8	40	80	50	15	12.0	-	-

Permitted alignment error for Super Runner Blocks at the guide rail and at the runner block

at the guide rail and at the runner block

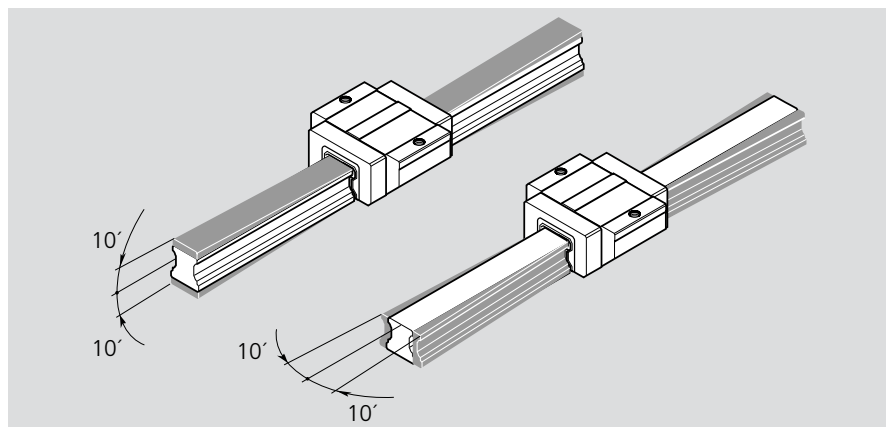

Mounting Instructions

Reference edges, corner radii, mounting screw sizes and tightening torque

Runner Block BNN

– Wide Low Profile

Guide rail:

– Wide, for mounting from above R1675

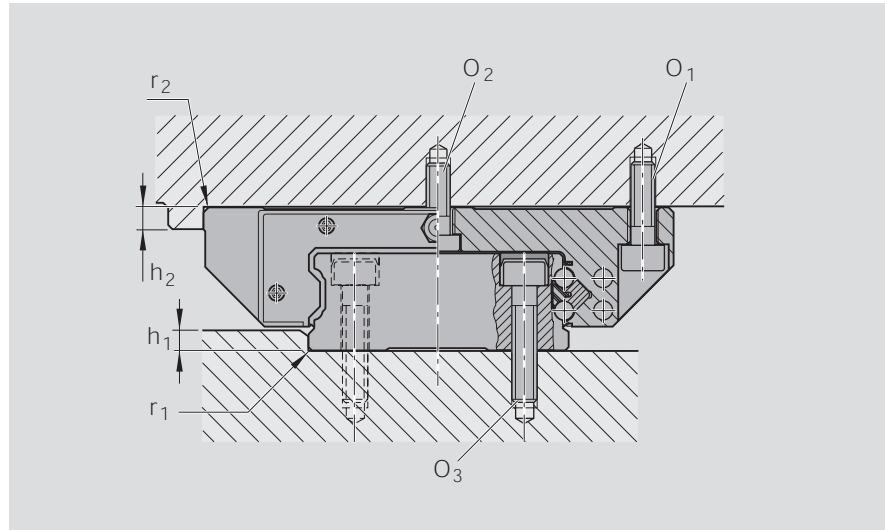

Runner Block BNN

– Wide Low Profile

Guide rail:

– wide, for mounting from below R1677

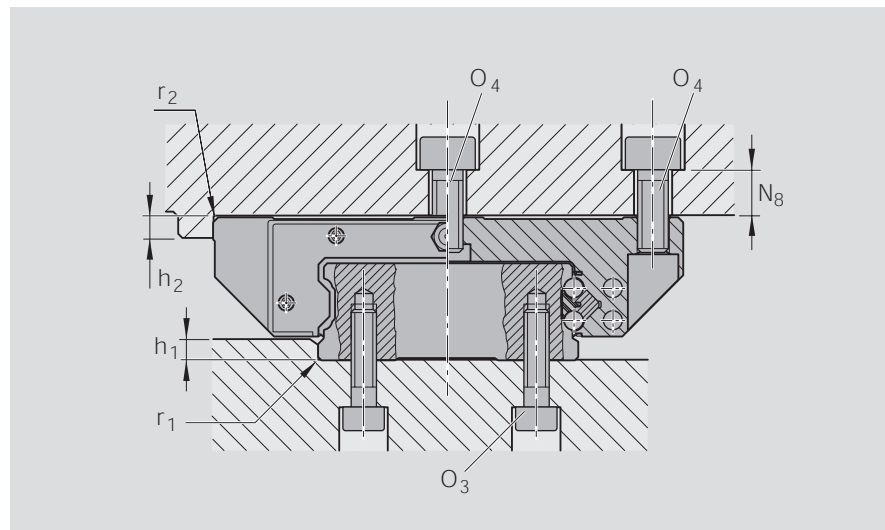

Dimensions and recommended limits for side load if no additional lateral retention is provided



1) When mounting the runner block from above using only 4 O₄ screws:
 – Permissible side force 1/3 lower
 – Lower stiffness

2) For runner block mounting with 6 screws:
 – Tighten the centerline screws with the torque for strength class 8.8

3) When mounting with 2 O₂ screws and 4 O₁ screws

Size	h ₁		r ₁	h ₂		r ₂	O ₁	O ₂ ²⁾	O ₄ ¹⁾²⁾	O ₃	O ₆	N ₈ (mm)
	min. (mm)	max. (mm)	max. (mm)	max. (mm)	max. (mm)	DIN 912 4 pcs.	DIN 6912 2 pcs.	DIN 912 6 pcs.	DIN 912	DIN 912		
20/40	2.0	2.5	0.5	4	0.5	M5x16	M5x12	M6x16	M4x20	M5x12	9.5	
25/70	3.0	4.5	0.8	5	0.8	M6x20	M6x16	M8x20	M6x30	M6x20	10.0	
35/90	3.5	6.0	0.8	6	0.8	M8x25	M8x20	M10x25	M8x35	M8x25	13.0	
Screw strength class		Runner blocks			Rails							
8.8		0.08 C	0.11 ³⁾ C	0.16 C	0.08 C							
12.9		0.13 C	0.16 ³⁾ C	0.24 C	0.13 C							

Tightening torque of the mounting screws

		M4	M5	M6	M8	M10
 Nm	8.8	2.7	5.5	9.5	23	46
	12.9	4.6	9.5	16	39	77

Mounting Instructions

Load on the screwed connection between guide rail and base

The screw connections specified in the standard DIN 645-1 can be subjected to excessive loads due to the performance capability of the profile guide rails. The mounting screws between guide rail and base are critical. If the lifting loads (F) or moments (M_t) are higher than the applicable load values in the table, the screw connections must be re-calculated separately.

The data applies to the following conditions:

- Mounting screws, quality 12.9
- Screws tightened using a torque wrench
- Screws lightly oiled
(for screws of quality 8.8, an approximate break factor of 0.6 can be applied)

Lift-off Loads and Moments

Guide rail mounted from above

Runner Blocks	R1663, R1664, R1665 R1666		R1621, R1622, R1651, R1693, R1694, R2001, R2011		R1623, R1624, R1653	
	$F_{max.}$ (N)	$Mt_{max.}$ (Nm)	$F_{max.}$ (N)	$Mt_{max.}$ (Nm)	$F_{max.}$ (N)	$Mt_{max.}$ (Nm)
15	6 040	41	7 050	47	8 060	54
20	10 000	90	11 700	106	13 400	121
25	14 600	154	17 100	180	19 500	205
30	–	360	32 400	420	37 100	480
35	27 500	440	32 100	510	36 700	580
45			78 100	1 680	89 300	1 920
55			107 800	2 690	123 200	3 080
65			152 300	4 490	174 100	5 130

Guide rail mounted from below

Runner Blocks	R1663, R1664, R1665 R1666		R1621, R1622, R1651, R1693, R1694, R2001, R2011		R1623, R1624, R1653	
	$F_{max.}$ (N)	$Mt_{max.}$ (Nm)	$F_{max.}$ (N)	$Mt_{max.}$ (Nm)	$F_{max.}$ (N)	$Mt_{max.}$ (Nm)
15	–	67	11 600	78	13 300	89
20	–	128	16 500	149	18 900	170
25	14 300	150	16 700	170	19 100	200
30	–	350	31 700	410	36 200	470
35	27 100	430	31 600	500	36 200	570
45			77 700	1 670	88 800	1 900
55			106 800	2 670	122 100	3 050
65			150 850	4 450	172 400	5 080

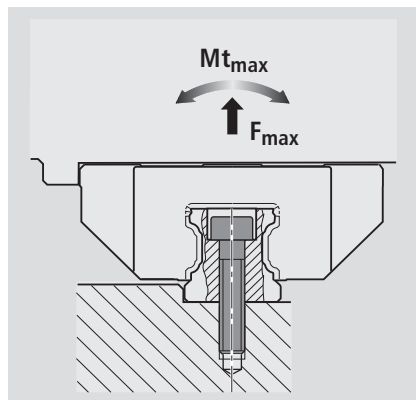

Wide Ball Rail Systems

Size	R1671	
	$F_{max.}$ (N)	$Mt_{max.}$ (Nm)
R1675	20/40	14 100
	25/70	33 500
	35/90	64 800
R1677	20/40	13 800
	25/70	33 700
	35/90	3 700

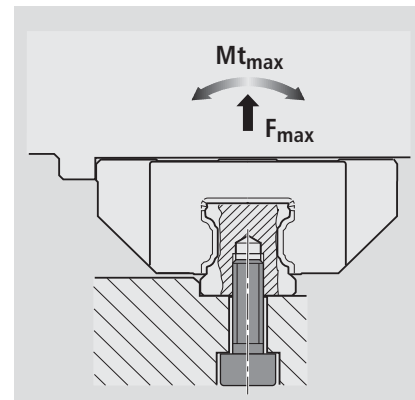

Mounting Instructions

Vertical offset

The vertical offset values apply to all runner blocks of the standard program. Values around 20% higher are permissible for the runner block R1665 (Standard Width, short) and R1666 (slimline, short).

If the admissible vertical offset S_1 and S_2 is not exceeded, reduction in travel life will as a rule be negligible.

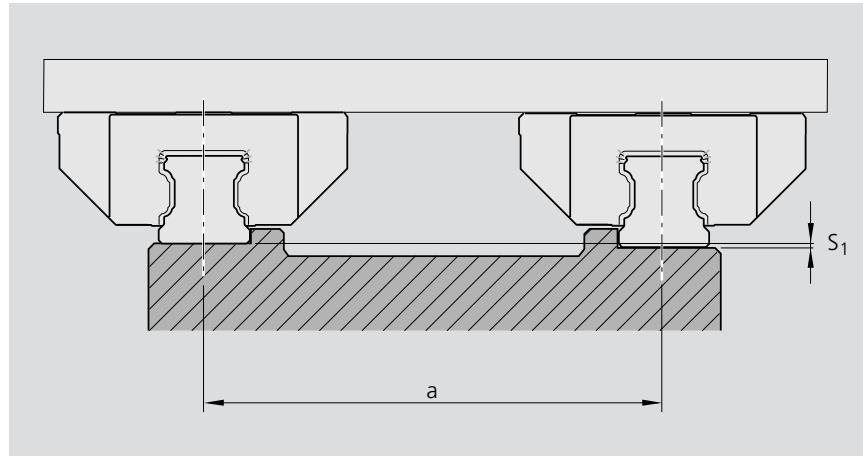

Permissible vertical offset in the transverse direction

The permissible offset S_1 includes the tolerance for dimension H as given in the table under "Technical Data".

$S_1 = a \cdot Y$	S_1 = Permissible vertical offset (mm) a = Distance between rails (mm) Y = Calculation factor
-------------------	-----------------------------------------------------------------------------------------------------------

Calculation factor Y for steel runner blocks

Calculation factor	for preload class			
	C0	C1	C2	C3
Y	$4.3 \cdot 10^{-4}$	$2.8 \cdot 10^{-4}$	$1.7 \cdot 10^{-4}$	$1.2 \cdot 10^{-4}$

Calculation factor Y for Super Runner Blocks

Calculation factor	for preload class	
	C0	C1
Y	$8 \cdot 10^{-4}$	$6 \cdot 10^{-4}$

Calculation factor Y for aluminum runner blocks

Calculation factor	for preload class	
	C0	C1
Y	$7 \cdot 10^{-4}$	$5 \cdot 10^{-4}$

Preload Class

- C0 = without Preload
- C1 = Preload 2% C
- C2 = Preload 8% C
- C3 = Preload 13% C

Mounting Instructions

Permissible vertical offset in the longitudinal direction

For steel and aluminum runner blocks

The permissible vertical offset S_2 takes into account the tolerance for the "max. difference in dimensions H on the same rail" according to the table given in the "Technical Data" section.

Values around 40% higher are permissible for the runner block R1665 (Standard Width, short) and R1666 (Slimline, short).

Values around 30% lower are permissible for runner block R1653 (standard width long), R1623 (slimline, long) and R1624 (slimline, high, long).

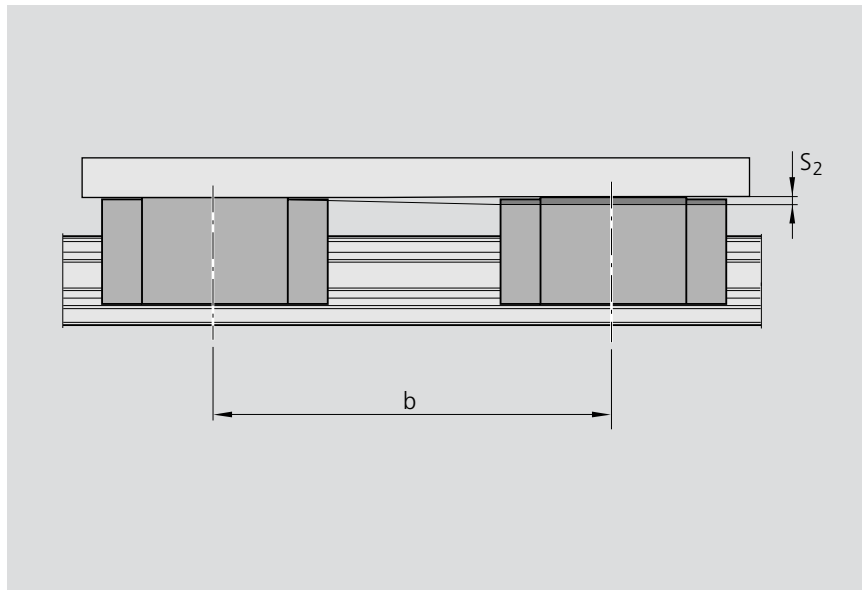

Permitted deviation S_2 for steel runner blocks

$S_2 = b \cdot 4.3 \cdot 10^{-5}$	S_2 = Permissible vertical offset (mm) b = Distance between runner blocks (mm)
-----------------------------------	---------------------------------------------------------------------------------------

Permitted deviation S_2 for aluminum runner blocks

$S_2 = b \cdot 6 \cdot 10^{-5}$	S_2 = Permissible vertical offset (mm) b = Distance between runner blocks (mm)
---------------------------------	---------------------------------------------------------------------------------------

Permissible deviation from straightness in the longitudinal direction with two consecutive Super Runner Blocks

The runner blocks can automatically compensate for a nonlinearity of 10' in the longitudinal direction.

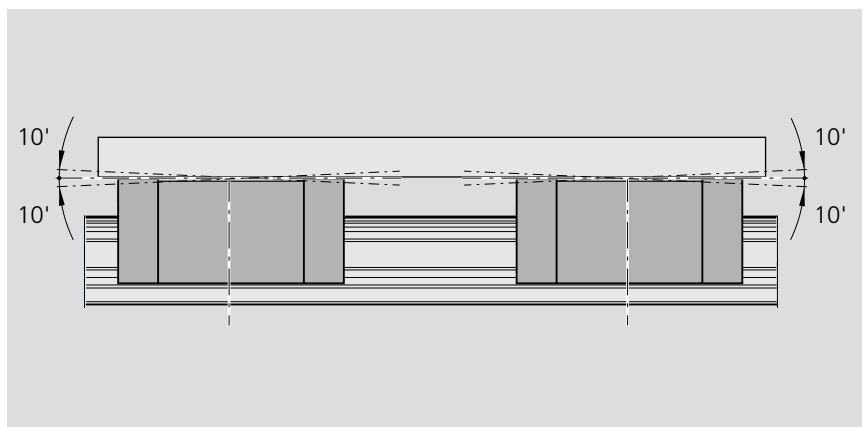

Mounting Instructions

Parallelism of the rails after mounting

measured at the guide rails and at the runner blocks

The values for parallelism offset P_1 apply to all runner blocks of the standard range.

Values around 20% higher are permissible for the runner block R1665 (Standard Width, short) and R1666 (slimline, short).

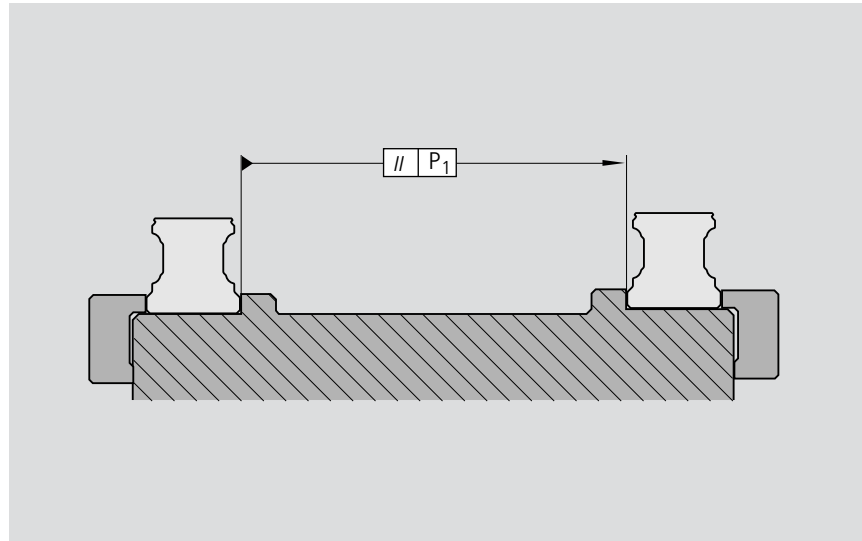

Parallelism offset P_1 for steel runner blocks

The parallelism offset P_1 causes a slight increase in preload on one side of the assembly.

If the tolerances given in the table are not exceeded, reduction in travel life will as a rule be negligible.

The given values apply to precision mounting. For standard mounting, double the stated values can be used.

Size	Parallelism offset P_1 (mm) for precision mounting			
	C0	C1	C2	C3
15	0.015	0.009	0.005	0.004
20	0.018	0.011	0.006	0.004
25	0.019	0.012	0.007	0.005
30	0.021	0.014	0.009	0.006
35	0.023	0.015	0.010	0.007
45	0.028	0.019	0.012	0.009
55	0.035	0.025	0.016	0.011
65	0.048	0.035	0.022	0.016

Parallelism offset P_1 for Super Runner Blocks

Size	Parallelism offset P_1 (mm)	
	C0	C1
15	0.025	0.017
20	0.029	0.021
25	0.032	0.023
30	0.035	0.026
35	0.040	0.030

Parallelism offset P_1 for aluminum runner blocks

Size	Parallelism offset P_1 (mm)	
	C0	C1
15	0.021	0.014
25	0.026	0.017
30	0.029	0.019
35	0.035	0.022

Preload Class

C0 = without Preload

C1 = Preload 2% C

C2 = Preload 8% C

C3 = Preload 13% C

Mounting Instructions

Composite guide rails

Guide rails made up of two sections

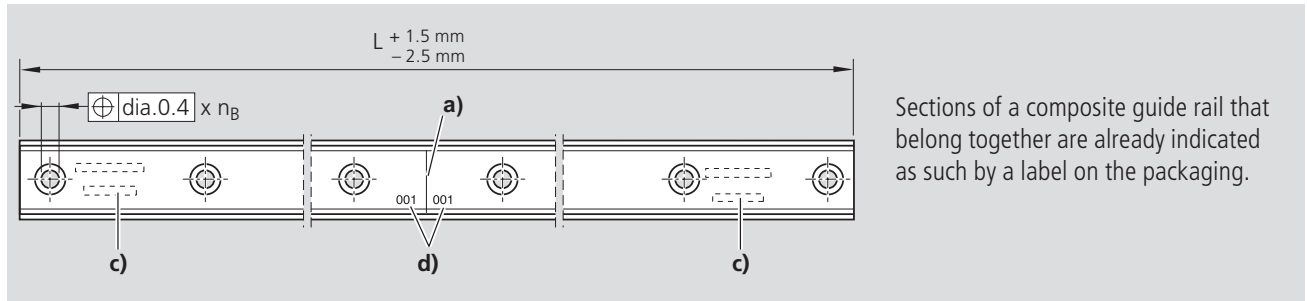

Guide rails made up of three or more sections

All sections of the same rail have the same number.

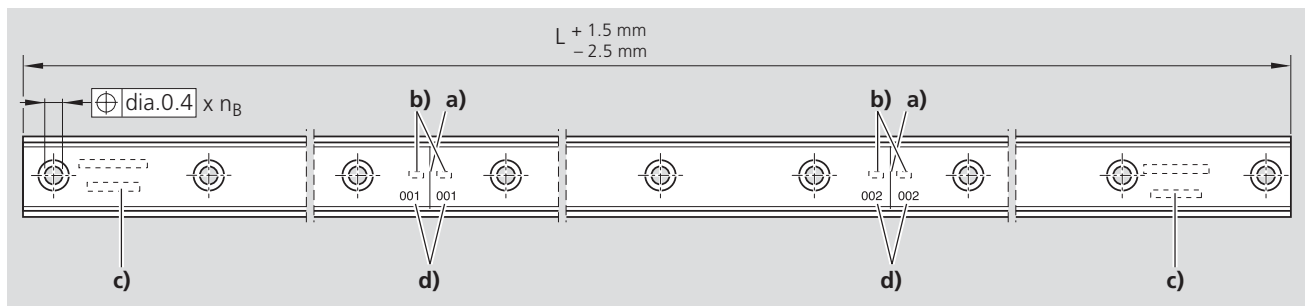

n_B Number of holes

- a) Joint
- b) Counter number
- c) Complete rail identification on first and last section
- d) Code number of the joint

Note on rail seal cover strip

For composite guide rails, a one-piece rail seal to cover the total length L is supplied separately.

Maintenance and Lubrication

Maintenance

Dirt can settle and encrust on guide rails, especially when these are not enclosed.

To ensure that seals and rail seal cover strips retain their functionality, this dirt must be removed at regular intervals.

It is advisable to run the machine through a full "cleaning cycle" over the entire installed rail length at least twice a day, but no later than at the end of every 8-hour shift.

Always run a cleaning cycle before shutting down the machine.

Rexroth Ball Rail Systems are delivered filled with an anti-corrosion agent. Either oil or grease can be used as a lubricant.

We recommend a lubricant grease to DIN 51825:

- K2K with normal loads
 - KP2K with higher loads
- with DIN 51818 can be purchased through Rexroth (cartridge content 400 g). Part number: 8416-037-00

Before start-up, make sure the system has sufficient initial lubrication.

Observe the information provided by the manufacturers, in particular with regard to incompatibilities.

 Greases with solid lubricant content (such as graphite or MoS₂) must not be used!

Lubrication

Grease Lubrication

Always lubricate runner blocks before start-up (initial lubrication)

Initial lubrication requires a total of three times the partial quantity given in table 1:

1. Apply the first partial quantity of lubricant as per table 1 to runner block.
2. Slide runner block back and forth over at least three times the block length for three full cycles.
3. Repeat steps 1. and 2. two more times
4. Check whether a film of lubricant is visible on the guide rail.

Size	Grease lubrication	
	Initial lubrication partial quantity lubrication (cm ³)	In-service (cm ³)
15	0.4 (x 3)	0.4 (x 2)
20	0.7 (x 3)	0.7 (x 2)
25	1.4 (x 3)	1.4 (x 2)
30	2.2 (x 3)	2.2 (x 2)
35	2.2 (x 3)	2.2 (x 2)
45	4.7 (x 3)	4.7 (x 2)
55	9.4 (x 3)	9.4
65	15.4 (x 3)	15.4
20/40	1.0 (x 3)	1.0
25/70	1.4 (x 3)	1.4
35/90	2.7 (x 3)	2.7

Table 1

Short stroke

Stroke < 2 · Runner block length

- Allow for 2 lubrication connections per runner block and lubricate each one.

Stroke < 0,5 · Runner block length

- Allow for 2 lubrication connections per runner block and lubricate each one.
- For each lubrication cycle, run the runner block 2x the runner block length. If this is not possible, please consult us.

lubricant quantity as stated in table 1 (maintenance lubrication). Supply the listed quantity of lubricant to each lubrication connection.

Size	Grease lubrication			
	Lubrication intervals under normal operating conditions, v ≤ 1 m/s			
	Part numbers R16.. ... 10; R16.. ... 11 Stroke (km)		Part numbers R16.. ... 20; R16.. ... 22 Stroke (km)	
	load ≤ 0,15 C	≤ 0,3 C	load ≤ 0,15 C	≤ 0,3 C
15	1000	240	5000	1200
20	1000	240	5000	1200
25	1000	240	10000	2400
30	1000	240	10000	2400
35	500	120	10000	2400
45	250	80		
55	150	35		
65	100	25		
20/40	1000	240		
25/70	1000	240		
35/90	500	120		

Table 2

* When using lubrication NLGI 00, the lubrication interval is reduced to 75 % of the listed values in table 2.

Maintenance and Lubrication

Oil lubrication

Oil quantities for initial and in-service lubrication

 Add the entire oil quantity in one go!

Runner blocks that have been initially lubricated at the plant can be re-lubricated with oil.

If the equipment is to operate in an environment subject to contamination, vibration, shock loads, etc., or where cooling lubricants are used, we recommend shortening the in-service lubrication interval.

* If a runner block is not initially lubricated at the plant, perform initial lubrication with double the oil quantity.

One-point oil lubrication

Oil quantities and lubrication intervals of central lubrication

Notes:

Recommended interval between two pulses: 10 seconds.

Example for size 45:

4 pulses of 0.6 cm³ each in 30 seconds.

If the equipment is to operate in an environment subject to contamination, vibration, shock loads, etc., or where cooling lubricants are used, we recommend shortening the in-service lubrication interval.

* If a runner block is not initially lubricated at the plant, perform initial lubrication with double the number of pulses.

Size	Oil Lubrication	
	Initial lubrication Quantity (cm ³)	In-service lubrication Quantity (cm ³)
15	0.4 (x 2)	0.4
20	0.7 (x 2)	0.7
25	1.0 (x 2)	1.0
30	1.1 (x 2)	1.1
35	1.2 (x 2)	1.2
45	2.2 (x 2)	2.2
55	3.6 (x 2)	3.6
65	6.0 (x 2)	6.0
20/40	0.7 (x 2)	0.7
25/70	1.1 (x 2)	1.1
35/90	1.8 (x 2)	1.8

Table 3

Size	Oil Lubrication			
	Lubrication intervals under normal operating conditions, v ≤ 1 m/s			
	Part numbers R16.. ... 10; R16.. ... 11		Part numbers R16.. ... 20; R16.. ... 22	
	Travel (km)		Travel (km)	
	Load ≤ 0.15 C	≤ 0.3 C	Load ≤ 0.15 C	≤ 0.3 C
15	600	120	2500	600
20	500	120	2500	600
25	500	120	5000	1200
30	500	120	5000	1200
35	250	60	5000	1200
45	125	30		
55	75	17		
65	50	12		
20/40	500	120		
25/70	500	120		
35/90	250	60		

Table 4

Size	Oil lubrication	Oil Lubrication
	quantity/pulse (cm ³)	Pulses per lubrication (cm ³)
15	0.6	1
20	0.6	1
25	0.6	2
30	0.6	2
35	0.6	2
45	0.6	4
55	1.5	3
65	1.5	4
20/40	0.6	1
25/70	0.6	2
35/90	0.6	3

Table 5

Maintenance and Lubrication

Dependency on the travel length

Stroke > 2 · runner block length

- Provide 1 lube port per runner block.
- Oil lubrication to ISO VG 220.
Lubricant quantities as per previous page.

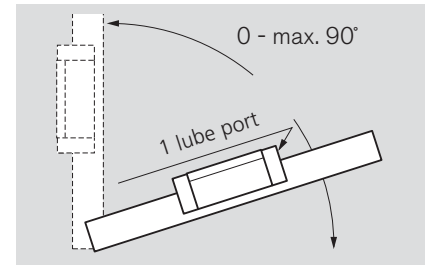
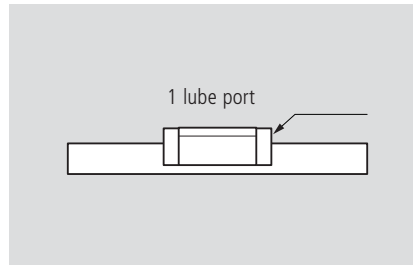

Stroke < 2 · runner block length:

- Provide 2 lube ports per runner block.
- Apply the specified lubricant quantity per lube port.
- Oil lubrication to ISO VG 220.
Lubricant quantities as per previous page.

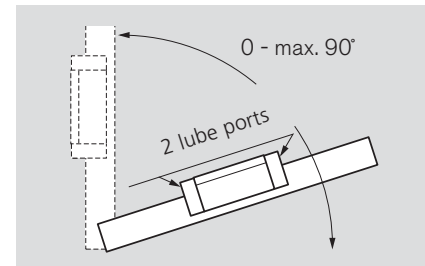
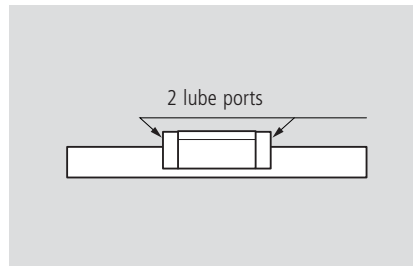

Installation at an angle about the centerline (wall mounting)

Stroke > 2 · runner block length:

- Provide 1 lube port per runner block.
- Add the lubricant quantity as specified in table in one pulse.
- If the lubrication quantity cannot be added in one pulse, please consult us.

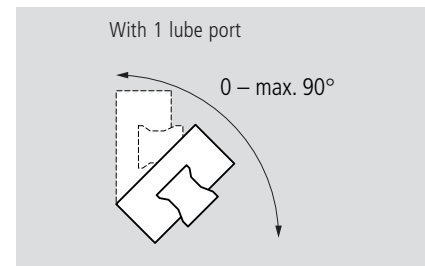
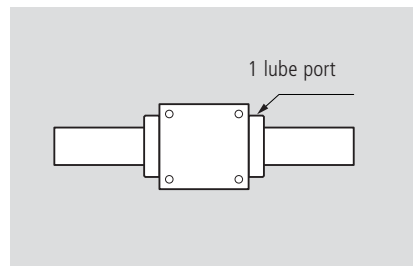

Stroke < 2 · runner block length:

- Provide 2 lube ports per runner block.
- Add the lubricant quantity as specified in table in one pulse.
- If the lubrication quantity cannot be added in one pulse, please consult us.

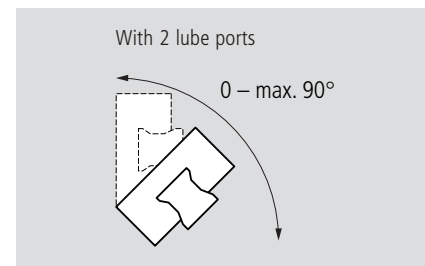
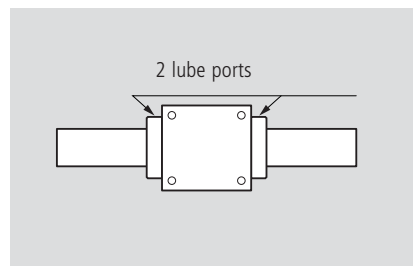

Maintenance and Lubrication

Lubricating from above

Lubricating from above without lubrication adapter

For all runner blocks with preparation for lubrication from above (exceptions: standard runner blocks R1621... and R1624...).

⚠ In the recess for the O-ring, a further small recess (1) has been pre-formed. Do not open this with a drill bit. Danger of contamination!

- Preheat the metal tip (2) with a diameter of 0.8 mm.
- Carefully open the recess (1) with the metal tip and pierce through it. Observe the maximum permissible depth T_{max} indicated in the table!
- Insert round sealing ring (3) in the recess (the round sealing ring is not supplied with the runner block).

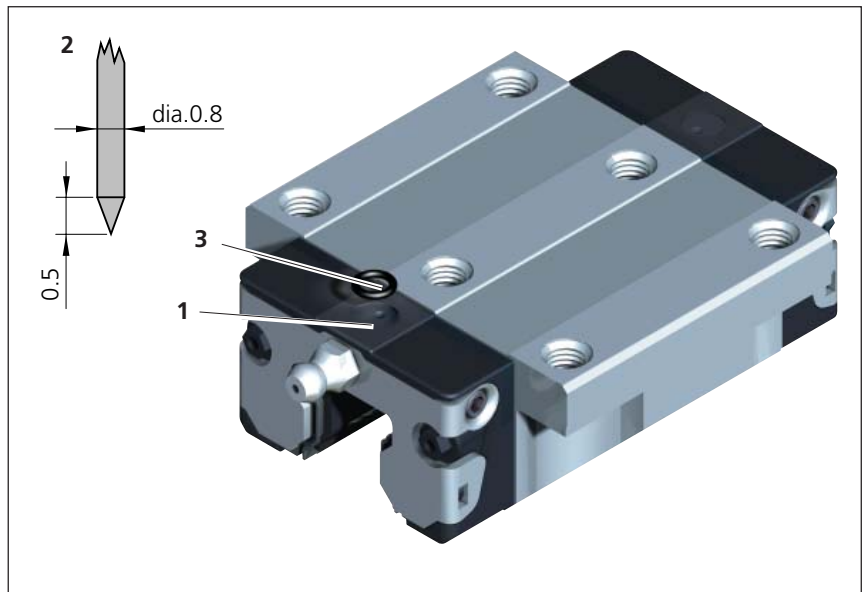

Size	Lube hole at top: max. perm. depth for piercing T_{max} (mm)
15	3.6
20	3.9
25	3.3
30	6.6
35	7.5
45	8.8

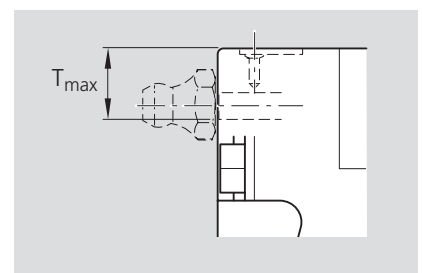

Special Lube Ports

Lube ports mounted on the top (1) or on the sides (2) are available on request.

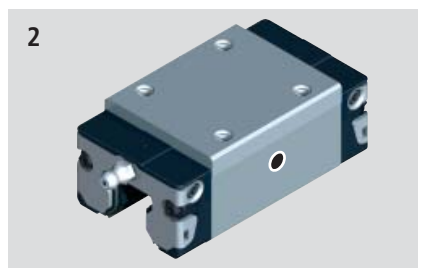
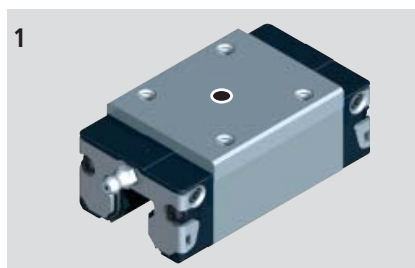

Recommended Lubricants

Manufacturer	Name	Specification NLGI	Part numbers 400 g-Cartridge
Rexroth	Dynalub 510	2	R3416 037 00
	Dynalub 520	00	R3416 043 00

Bosch Rexroth AG
Linear Motion and
Assembly Technologies
Ernst-Sachs-Straße 100
97424 Schweinfurt, Germany
Telephone +49 97 21 9 37-0
Telefax +49 97 21 9 37-2 75 (general)
Telefax +49 97 21 9 37-2 50 (direct)
Internet www.boschrexroth.com/brl
E-Mail info.brl@boschrexroth.de

Subject to technical modifications