

# Roller Rail Systems

RE 82 302/2003-04

The Drive & Control Company

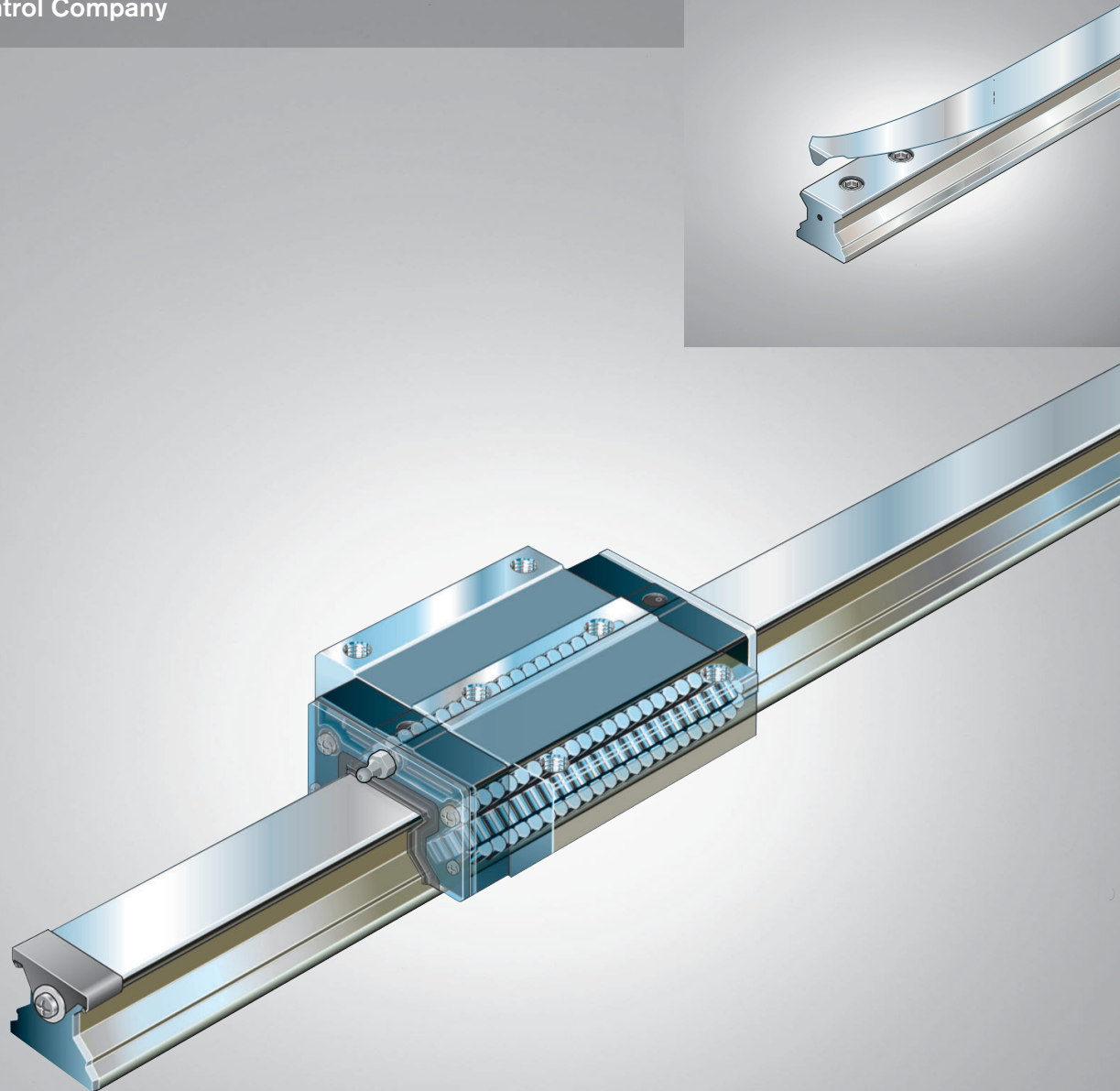

# Rexroth Linear Motion Technology

## Ball Rail Systems

Standard Ball Rail Systems  
Super Ball Rail Systems  
Ball Rail Systems with Aluminum Runner Blocks  
High Speed Ball Rail Systems  
Corrosion-Resistant Ball Rail Systems  
Wide Ball Rail Systems

---

Ball Rail Systems with Integrated Measuring System  
Braking and Clamping Units for Ball Rail Systems  
Rack and Pinion for Ball Rail Systems  
Miniature Ball Rail Systems  
Cam Roller Guides

## Roller Rail Systems

Standard Roller Rail Systems  
Wide Roller Rail Systems  
Heavy Duty Roller Rail Systems  
Roller Rail Systems with Integrated Measuring System  
Braking and Clamping Units for Roller Rail Systems  
Rack and Pinion for Roller Rail Systems

## Linear Bushings and Shafts

Linear Bushings, Linear Sets  
Shafts, Shaft Support Rails, Shaft Support Blocks

---

Ball Transfer Units  
Traditional Engineering Components

## Screw Drives

### Linear Motion Systems

Linear Motion Slides

- Ball Screw Drive
- Toothed Belt Drive

Linear Modules

- Ball Screw Drive
- Toothed Belt Drive
- Rack and Pinion Drive
- Pneumatic Drive
- Linear Motor

Compact Modules

- Ball Screw Drive
- Toothed Belt Drive
- Linear Motor

Precision Modules

- Ball Screw Drive

Ball Rail Tables

- Ball Screw Drive
- Linear Motor

---

Controllers, Motors, Electrical Accessories  
Linear Actuators

# Rexroth Roller Rail Systems

## Contents

<b>General Product Description</b>			
New Features at a Glance	4		
General Product Overview	6		
Product Overview with Load Capacities and Rail Lengths	8		
Combination Options	14		
General Technical Data	16		
Calculations	17		
Notes on Seals and Scrapers	19		
General Mounting Instructions	20		
Mounting Instructions for the Cover Strip	24		
<b>Standard Steel Runner Blocks</b>			
Product Overview	26		
Product Description	28		
Technical Data	29		
Mounting Instructions	38		
Standard Steel Runner Blocks	40		
Standard Steel Runner Blocks for Wall Mounting	48		
Standard Steel Runner Blocks with Aluminum End Caps	50		
Standard Steel Runner Blocks, Hard Chrome-Plated	54		
<b>Standard Guide Rails</b>			
Product Overview and Ordering Examples	56		
Standard Guide Rails	58		
Standard Guide Rails, Hard Chrome-Plated	70		
<b>Wide Steel Runner Blocks</b>			
Product Overview	78		
Product Description	80		
Technical Data	81		
Mounting Instructions	86		
Wide Steel Runner Blocks	88		
Wide Guide Rails	90		
Wide Guide Rails, Hard Chrome-Plated	92		
<b>Heavy Duty Steel Runner Blocks</b>			
Product Overview	94		
Product Description	96		
Technical Data	97		
Mounting Instructions	100		
Heavy Duty Steel Runner Blocks	102		
Heavy Duty Guide Rails	106		
Heavy Duty Guide Rails, Hard Chrome-Plated	108		
<b>Accessories</b>			
Product Overview –			
Accessories and Combination Options		110	
Accessories for Standard Runner Blocks		114	
Metal scraper		114	
One-piece Viton wiper seal		115	
Standard lube plate		118	
Lube adaptor		120	
Front lube units		121	
Protective bellows		126	
Accessories for Guide Rails		129	
Cover strip, separate		129	
Cover strip mounting kit		130	
Expanding tool		130	
Protective caps, strip clamp		131	
Mounting hole plugs		132	
Mounting tool for steel mounting hole plugs		132	
General Accessories – Runner Blocks		133	
Tapered lube nipple		133	
Lube fittings		133	
Tube connectors		134	
O-rings		134	
Mounting handle		135	
General Accessories – Guide Rails		135	
Adjusting shafts		135	
Mounting runner block		136	
Wedge profile for lateral retention of the guide rails		138	
<b>Spare Parts</b>			
End seal		139	
Set of end caps with end seals		140	
Set of aluminum end caps with end seals		140	
Transport and mounting arbor for runner blocks		140	
<b>Lubrication</b>			
Dry axes and axes with minimal use of coolants		141	
Wet axes with liberal use of coolants		144	
<b>Maintenance</b>			
Cleaning cycle		145	
Checking accessories		145	

# Rexroth Roller Rail Systems

## New Features at a Glance

### New Roller Rail Systems

For high moment load capacities and maximum rigidity:

#### Rexroth Wide Roller Rail Systems

Sizes 55/85 and 65/100

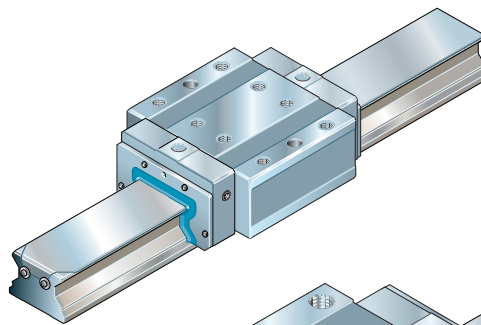

For heavy duty applications:

#### Rexroth Heavy Duty Roller Rail Systems

Size 125

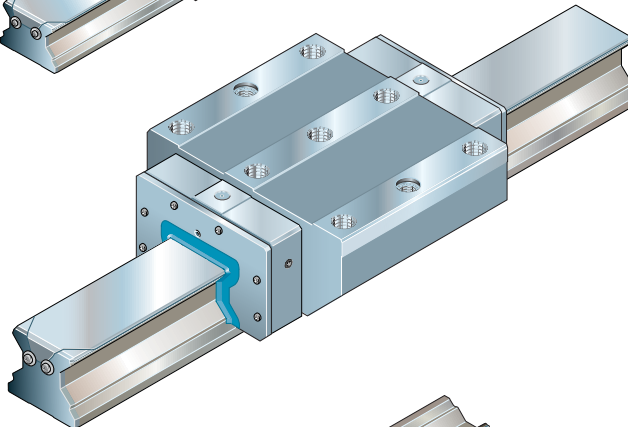

For special applications and environments:

#### Standard steel runner blocks for wall mounting

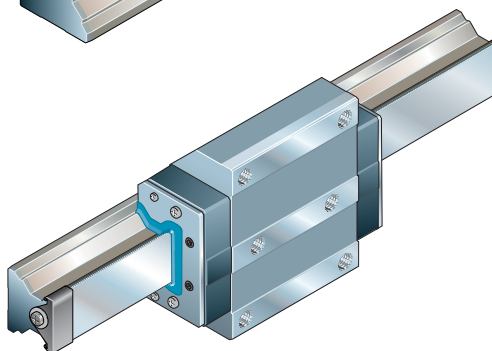

For hostile environments:

#### Standard steel runner blocks with aluminum end caps

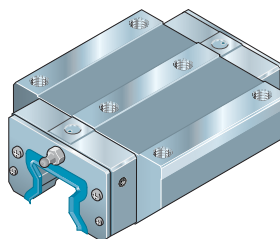

### Coatings

In certain accuracy classes, the runner blocks and guide rails are available with:

- hard chrome-plating (replaces zinc-iron coating)

### Sizes

Standard-width runner block now also available in size 65.

### Preload classes

Runner blocks in preload class 0.03 C on request.  
Runner blocks in preload class 0.08 C are preferred.

Recommended preload-accuracy combination:

Preload class 0.08 C: H and P

Preload class 0.13 C: P and SP

## **New accessories for runner blocks**

- Metal scraper with spacer plate
- Viton/NBR wiper seal
- Lubrication plate
- Front lubrication unit
- O-rings
- Mounting handle
- Set of end seals
- Set of end caps with end seals
- Set of aluminum end caps with end seals
- Transport and mounting arbor

## **New lubrication fittings:**

- Reducers
- Connectors
- Extension pieces
- Swivel fittings
- Tube connectors

## **New accessories for guide rails**

- Cover strip
- Mounting kit: tool and lift-off plate
- Expanding tool
- Strip clamp
- Two-piece mounting tool for fitting steel mounting hole plugs
- Adjusting shafts
- Mounting runner block

# Rexroth Roller Rail Systems

## General Product Overview

Rexroth Roller Rail Systems were specially developed for use in machine tools and industrial robots calling for compact, rolling-element linear motion guideways. They are available in various accuracy classes, each with extremely high load capacity and high rigidity.

These space-saving assemblies in 5 common sizes afford the same high load capacities in all four major planes of load application.

### **Make up your own compact linear motion guideways from interchangeable standard stock elements...**

Rexroth fabricates its guide rails and runner blocks with such high precision that each individual component element can be replaced by another at any time. This makes infinite combinations possible. Each element can be individually ordered and separately stocked.

Both sides of the guide rail can be used as reference edges.

Accessories can be simply attached to the ends of the runner block.

- Uniform guide rail profile with or without cover strip allows unrestricted interchangeability of components across all runner block variants.
- Lube ports on all sides for maximum ease of maintenance.
- Novel lube duct design minimizes lubricant consumption.
- Innovative cage design allows for longer lubrication intervals.
- Smooth running thanks to optimized roller recirculation and guidance.
- Mounting of attachments to runner block from above or below.
- Improved rigidity under lift-off and side loading conditions through additional mounting screw holes at the center of the runner block.
- Optimized entry-section geometry and high number of rollers per track minimizes variation in elastic deflection.
- The roller block simply slides off its arbor and onto the rail.

For all applications:

### **Standard Roller Rail Systems**

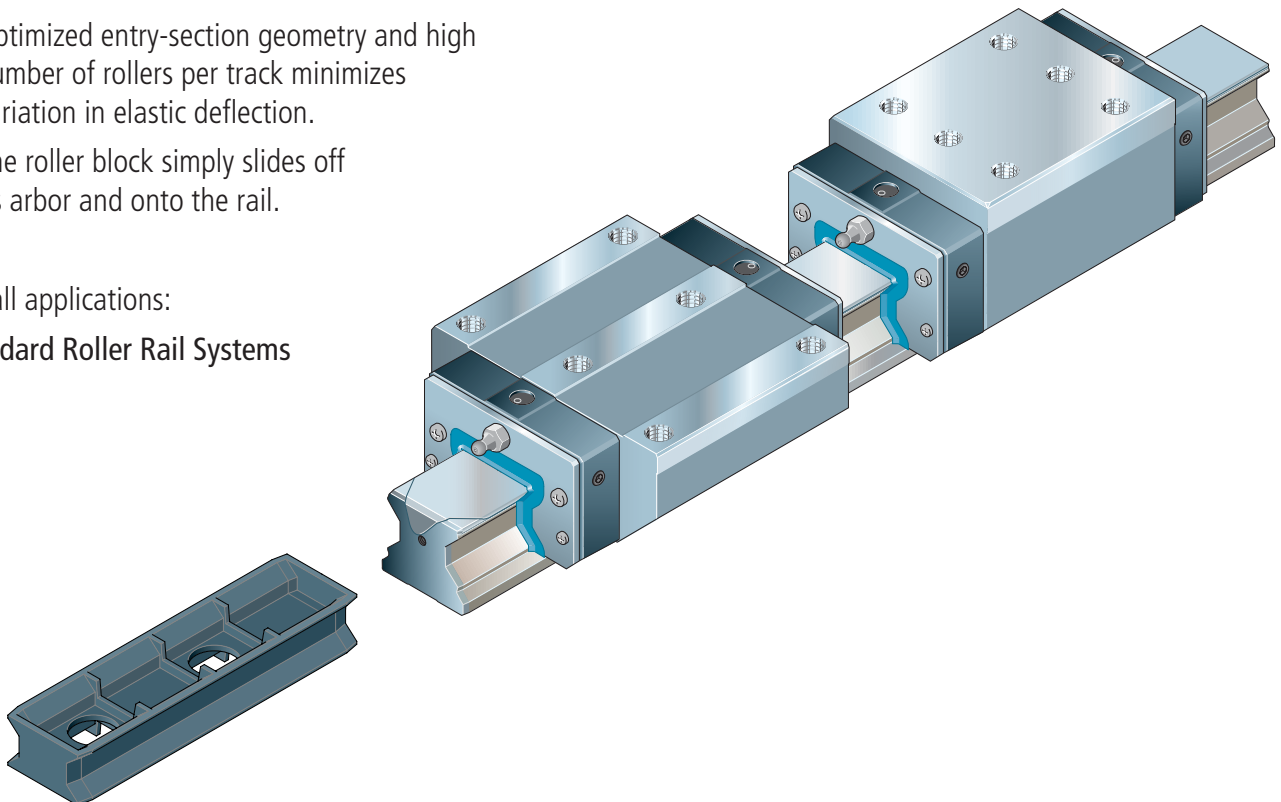

## General Product Overview

- Maximum rigidity under load from all directions
- High torque capacity
- Integrated all-round sealing
- End seal as standard
- Guide rails and runner blocks also available hard chrome-plated

Proven cover strip for guide rail mounting holes:

- A *single* cover for all holes
- Stainless spring steel to EN 10088
- Easy to fit – simply clip on and secure

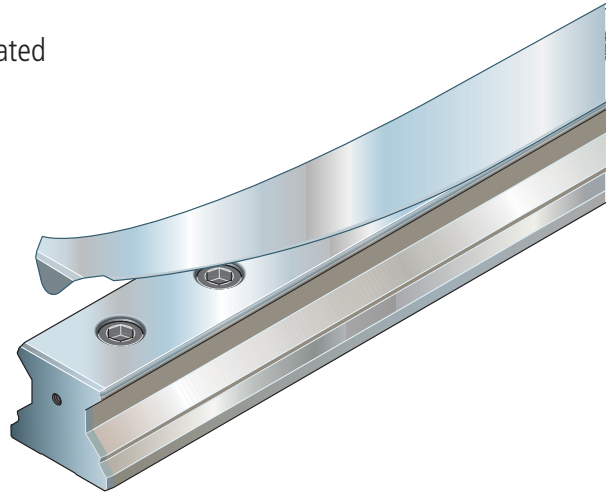

For high moment load capacities and maximum rigidity:

**Rexroth Wide Roller Rail Systems**

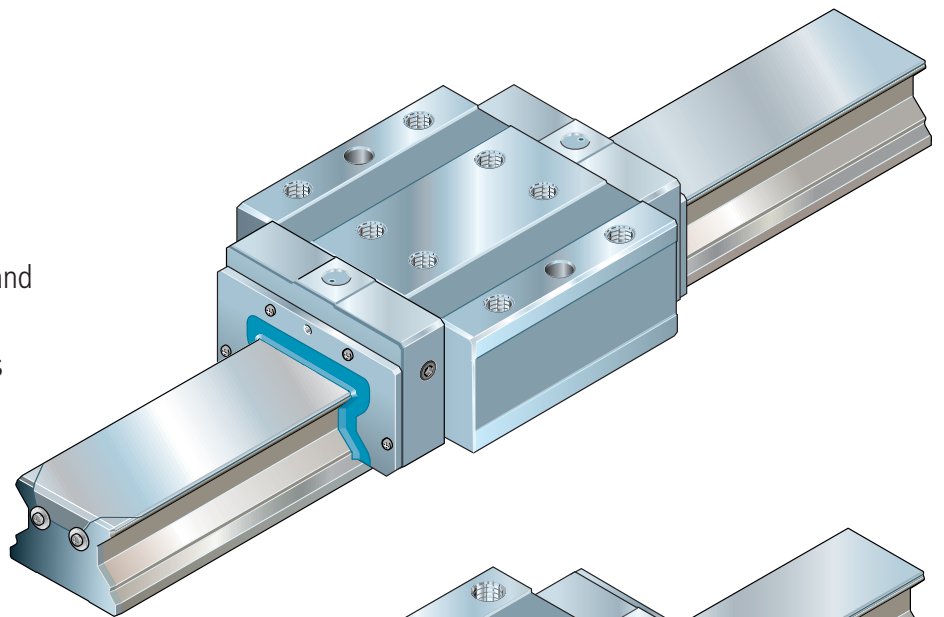

For heavy duty applications:

**Rexroth Heavy Duty Roller Rail Systems**

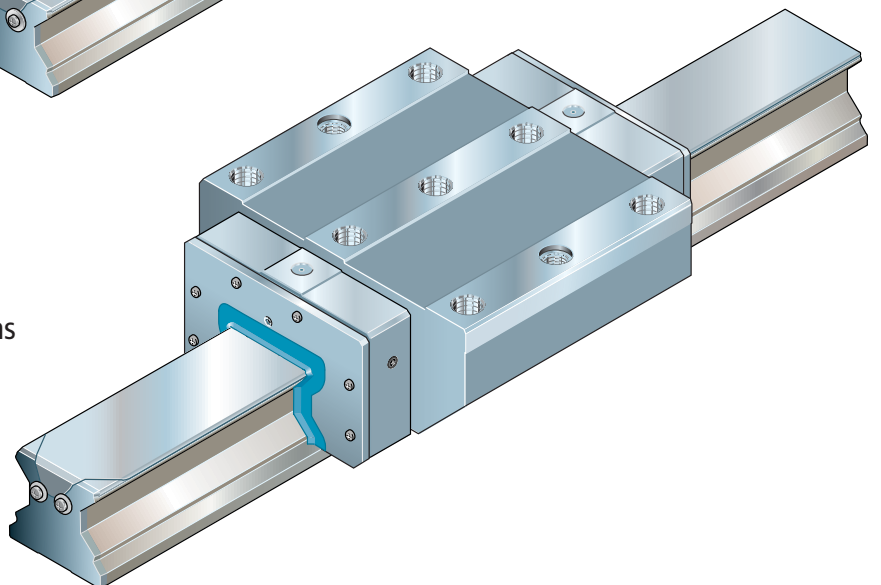





Size	25	35	45	55	65	
<b>Load capacities</b>						
C (N)	26900	56300	92300	128900	207000	
C <sub>0</sub> (N)	53200	113500	184800	248600	382000	
C (N)	33300	69700	119200	165000	265500	
C <sub>0</sub> (N)	70000	149300	256600	345300	525600	
C (N)	26900	56300	92300	128900	–	
C <sub>0</sub> (N)	53200	113500	184800	248600	–	
C (N)	33300	69700	119200	165000	265500	
C <sub>0</sub> (N)	70000	149300	256600	345300	525600	

# Rexroth Roller Rail Systems

## Product Overview with Load Capacities and Rail Lengths

### Standard Roller Rail Systems

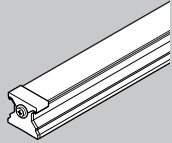
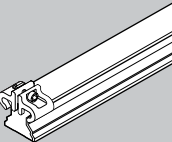
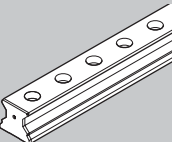
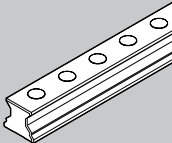
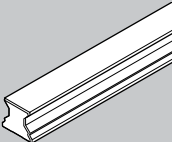
		Page		
<p><b>Standard guide rails</b></p> <p>* For special applications. Standard length up to 4000 mm</p>	<p>For mounting from above, with cover strip and screw-down protective caps <b>1805-.6.-</b></p> <p>Special versions: hard chrome-plated <b>1845-.5.-</b></p> 	<p><b>58</b></p> <p><b>70</b></p>		
	<p>For mounting from above, with cover strip and strip clamp <b>1805-.3.-</b></p> 	<p><b>60</b></p>		
	<p>For mounting from above, for cover strip <b>1805-.2.-</b></p> <p>Special versions: hard chrome-plated <b>1845-.8.-</b></p> 	<p><b>62</b></p> <p><b>72</b></p>		
	<p>For mounting from above, with plastic mounting hole plugs <b>1805-.5.-</b> for steel mounting hole plugs <b>1806-.5.-</b></p> <p>Special versions: hard chrome-plated <b>1845-.1.-</b></p> 	<p><b>64</b></p> <p><b>66</b></p> <p><b>74</b></p>		
	<p>For mounting from below <b>1807-.0.-</b></p> <p>Special versions: hard chrome-plated <b>1847-.1.-</b></p> 	<p><b>68</b></p> <p><b>76</b></p>		

	Size	25	35	45	55	65
	Maximum length per one-piece section (mm)					
		4000	6000*	6000*	6000*	6000*
		4000	4000	4000	4000	4000
		4000	6000*	6000*	6000*	6000*
		4000	6000*	6000*	6000*	6000*
		4000	4000	4000	4000	4000
		4000	6000*	6000*	6000*	6000*
		4000	4000	4000	4000	4000
		4000	4000	4000	4000	4000
		4000	4000	4000	4000	4000

# Rexroth Roller Rail Systems

## Product Overview with Load Capacities and Rail Lengths

### Wide Roller Rail Systems

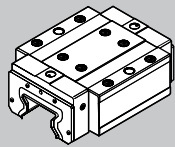
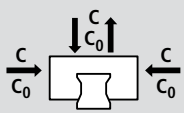
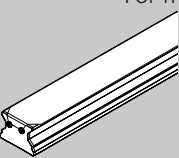
		Page		
Wide steel runner blocks	 <p>Wide runner block <b>1872-</b></p> <p>Special versions: hard chrome-plated <b>1872-...-60</b></p>	88		
Wide guide rails	 <p>For mounting from above, with cover strip <b>1875-.6.-</b></p> <p>Special versions: hard chrome-plated <b>1873-.53-</b></p>	90		
		92		

### Heavy Duty Roller Rail Systems

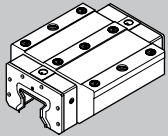
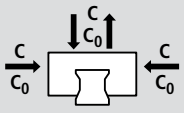
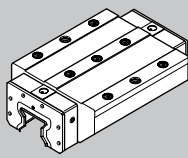
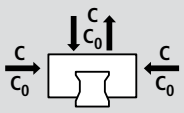
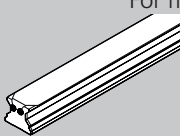
		Page		
Heavy duty steel runner blocks	 <p>Standard width <b>1861-</b></p> <p>Special versions: hard chrome-plated <b>1861-...-60</b></p>	102		
Heavy duty steel runner blocks	 <p>Standard width, long <b>1863-</b></p> <p>Special versions: hard chrome-plated <b>1863-...-60</b></p>	104		
Heavy duty guide rails	 <p>For mounting from above, with cover strip <b>1835-.6.-</b></p> <p>Special versions: hard chrome-plated <b>1865-35.-</b></p>	106		
		108		

Size	55/85	65/100
------	-------	--------

Load capacities						
-----------------	--	--	--	--	--	--

$C_0$ (N)				165000	265500	
$C_0$ (N)				345300	525600	

Maximum length per one-piece section (mm)						
---	--	--	--	--	--	--

				4000	6000	
				4000	4000	

Size	125
------	-----

Load capacities						
-----------------	--	--	--	--	--	--

$C$ (N)				603000		
$C_0$ (N)				1324000		

$C$ (N)				1020000		
$C_0$ (N)				1941900		

Maximum length per one-piece section (mm)						
---	--	--	--	--	--	--

				2634		
				2634		

# Rexroth Roller Rail Systems

## Combination Options

Rexroth profiled rail systems are no "off-the-peg" products. They can be assembled in any desired combination for optimal customization to the user's specific application, true to our motto:

**Make up your own compact linear motion guideways from interchangeable standard stock elements...**

Modular design at its best.

### Standard runner blocks

**Runner block** 1851...-10  
standard width  
for wall mounting 1851...-18  
with aluminum end caps 1851...-13  
hard chrome-plated 1851...-60

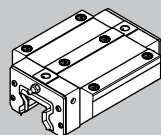

**Runner block** 1853...-10  
standard width, long  
for wall mounting 1853...-18  
with aluminum end caps 1853...-13  
hard chrome-plated 1853...-60

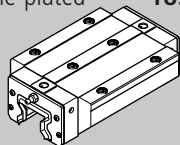

**Runner block** 1821...-10  
slimline, high  
for wall mounting 1821...-18  
with aluminum end caps 1821...-13  
hard chrome-plated 1821...-60

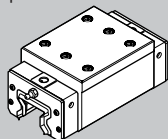

**Runner block** 1824...-10  
slimline, high, long  
for wall mounting 1824...-18  
with aluminum end caps 1824...-13  
hard chrome-plated 1824...-60

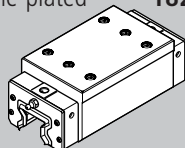

... can be combined with...  
to form a complete guideway unit.

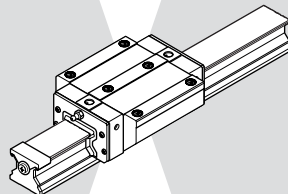

### Standard guide rails

**Guide rail** 1805-.6.-  
for mounting from above, with  
cover strip and protective caps  
hard chrome-plated 1845-.5.-

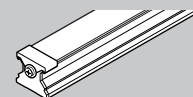

**Guide rail** 1805-.3.-  
for mounting from above, with  
cover strip and strip clamp

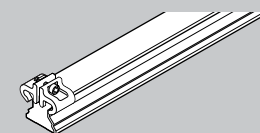

**Guide rail** 1805-.2.-  
for mounting from above,  
for cover strip  
hard chrome-plated 1845-.8.-

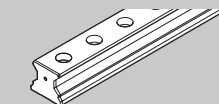

**Guide rail** 1805-.5.-  
for mounting from above, with  
plastic mounting hole plugs  
hard chrome-plated 1845-.1.-

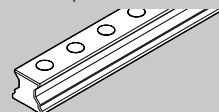

**Guide rail** 1806-.5.-  
for mounting from above, for steel  
mounting hole plugs

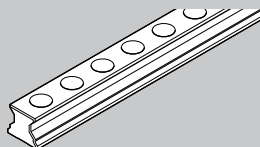

**Guide rail** 1807-.0.-  
for mounting from below  
hard chrome-plated 1847-.1.-

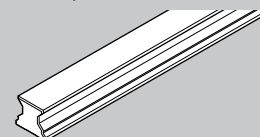

# Combination Options

## Wide runner blocks

**Runner block** 1872-...-10  
wide  
hard chrome-plated 1872-...-60

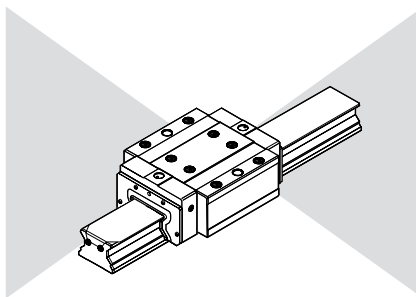
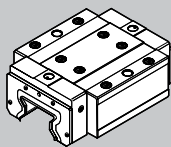

**Guide rail** 1875-.6.-  
wide, for mounting from  
above, with cover strip  
hard chrome-plated 1873-.53-

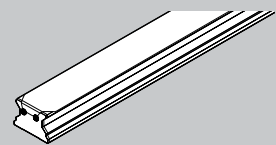

## Heavy duty runner blocks

**Runner block** 1861-3..-10  
heavy duty, standard width  
hard chrome-plated 1861-3..-60

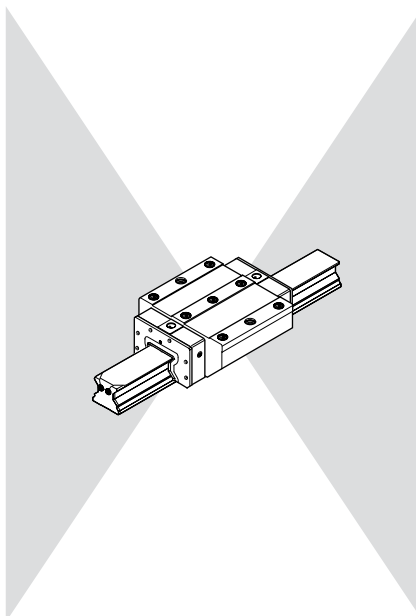
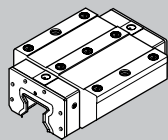

**Guide rail** 1835-36.-  
heavy duty, for mounting  
from above, with cover strip  
hard chrome-plated 1865-353-

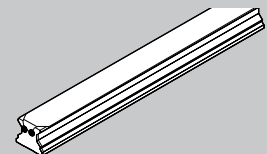

**Runner block** 1863-3..-10  
heavy duty, standard width, long  
hard chrome-plated 1863-3..-60

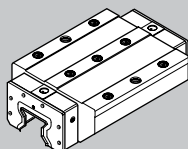

# Rexroth Roller Rail Systems

## General Technical Data

### Preload classes

To cater for the widest possible range of applications Rexroth Roller Rail Systems are provided in three different preload classes.

To prevent any shortening of service life, the preload should not exceed 1/3 of the bearing load F.

The following preload classes are available as standard:

0.08 C      0.13 C  
0.03 C on request

### General data

#### Velocity

$$v_{\max} = 2 \text{ m/s}$$

Speeds of up to 3 m/s are possible. Service life is limited by wear of plastic parts.

#### Acceleration

$$a_{\max} = 50 \text{ m/s}^2$$

Requirement: The Roller Rail System must always be preloaded, even when operated under load!

#### Operating temperature

$$t_{\max} = 100^{\circ}\text{C}$$

### Friction

The friction coefficient  $\mu$  is approx. **0.001** (excluding seal friction).

Reference values for the frictional force in a sealed and lubricated complete runner block.

The values apply to all runner blocks in all preload classes.

Size	$F_f$ [N]
25	30.0
35	40.0
45	60.0
55	70.0
65	90.0
55/85	70.0
65/100	90.0
125	600

$F_f$  = frictional force



# Calculations

## Nominal life

Calculate the nominal travel life  $L$  or  $L_h$  according to formula (1), (2) or (3):

### - at constant speeds

$(1) \quad L = \left(\frac{C}{F}\right)^{\frac{10}{3}} \cdot 10^5$	$L$ = nominal life (m) $L_h$ = nominal life (h) $C$ = dynamic load capacity (N) $F$ = equivalent dynamic load (N)
$(2) \quad L_h = \frac{L}{2 \cdot s \cdot n \cdot 60}$	$s$ = stroke length (m) $n$ = stroke repetition rate (full cycles) ( $\text{min}^{-1}$ )

### - at variable speeds

$(3) \quad L_h = \frac{L}{60 \cdot v_m}$	$L$ = nominal life (m) $L_h$ = nominal life (h) $v_m$ = average speed (m/min)
$(4) \quad v_m = \frac{t_1 \cdot v_1 + t_2 \cdot v_2 + \dots + t_n \cdot v_n}{100}$	$v_1, v_2, \dots, v_n$ = discrete speed steps (m/min) $t_1, t_2, \dots, t_n$ = percentage of stroke covered at $v_1, v_2, \dots, v_n$ (%)

## Equivalent dynamic loads on bearings for calculation of nominal life

If the bearings are subjected to variable loads, calculate the equivalent dynamic load  $F$  according to formula (5):

### - under variable loads

$(5) \quad F = \sqrt[10]{F_1^{\frac{10}{3}} \cdot \frac{q_1}{100} + F_2^{\frac{10}{3}} \cdot \frac{q_2}{100} + \dots + F_n^{\frac{10}{3}} \cdot \frac{q_n}{100}}$	$F$ = equivalent dynamic load (N) $F_1, F_2, \dots, F_n$ = discrete dynamic load steps (N) $q_1, q_2, \dots, q_n$ = percentage of stroke covered under $F_1, F_2, \dots, F_n$ (%)
---	---

### - under combined loads

If the bearings are subjected to combined loads (vertical and horizontal), calculate the equivalent dynamic load  $F$  according to formula (6):

Note:  
The structure of Roller Rail Systems allows this simplified calculation.

$(6) \quad F =  F_V  +  F_H $	$F$ = equivalent dynamic load (N) $F_V$ = external dynamic load, vertical (N) $F_H$ = external dynamic load, horizontal (N)
-------------------------------	---

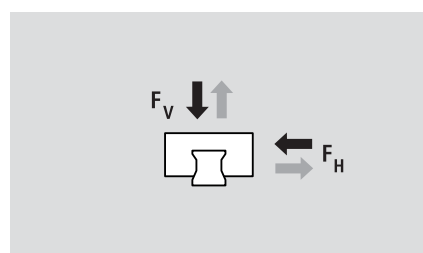

### Notes

If  $F_V$  and  $F_H$  involve several different load levels, they have to be calculated separately using formula (5).

An external load acting at an angle on the runner block is to be broken down into its  $F_V$  and  $F_H$  components, whose values are then to be used in formula (6).

# Rexroth Roller Rail Systems

## Calculations

### Equivalent dynamic loads on bearings for calculation of nominal life

- under combined loads in combination with a moment

If the bearings are subjected to combined external loads (vertical and horizontal) in combination with a moment, calculate the equivalent dynamic load  $F$  according to formula (7):

Formula (7) is only applicable if a single guide rail is used.

$(7) F =  F_V  +  F_H  + C \cdot \frac{ M }{M_t}$	$F$ = equivalent dynamic load (N) $F_V, F_H$ = external dynamic loads (N) $M$ = dynamic moment (Nm) $C$ = dynamic load capacity * (N) $M_t$ = permissible dynamic moment * (Nm) * see load capacity tables
---	---

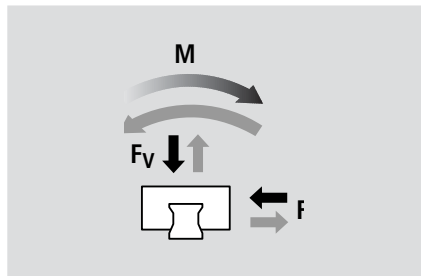

#### Notes

If  $F_V$  and  $F_H$  involve several different load levels, they have to be calculated separately using formula (5).

An external load acting at an angle on the runner block is to be broken down into its  $F_V$  and  $F_H$  components, whose values are then to be used in formula (7).

### Equivalent static load on bearing

If bearings are subjected to combined static loads (vertical and horizontal) in combination with a static moment, calculate the equivalent static load  $F_0$  according to formula (8).

The equivalent static load  $F_0$  must not exceed the static load capacity  $C_0$ .

Formula (8) is only applicable if a single guide rail is used.

$(8) F_0 =  F_{V0}  +  F_{H0}  + C_0 \cdot \frac{ M_0 }{M_{t0}}$	$F_0$ = equivalent static load (N) $F_{V0}, F_{H0}$ = external static loads (N) $M_0$ = static moment (Nm) $C_0$ = static load capacity * (N) $M_{t0}$ = permissible static moment * (Nm) * see load capacity tables
--	---

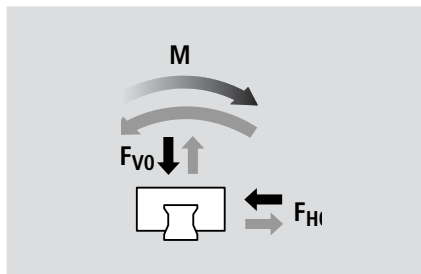

#### Note

An external load acting at an angle on the runner block is to be broken down into its  $F_{V0}$  and  $F_{H0}$  components, whose values are then to be used in formula (8).

## Notes on Seals and Scrapers

### Seals / scrapers

Additional seals and scrapers are intended to prevent dirt, chips, etc. from entering the runner block and to avoid premature termination of its useful life.

### Standard version:

#### Internal universal seal and end seal

Universal seals and end seals are standard built-in features of Rexroth runner blocks.

They provide uniform sealing efficiency on guide rails with and without cover strip.

#### Wiper seals

Viton or NBR seals are optional accessories to be fitted by the customer.

For use in environments heavily soiled with fine dirt or metal particles, or where coolants and cutting fluids are used.

Replaceable.

A two-piece version is also available.

#### Metal scrapers

Metal scrapers with spacer plates are optional accessories to be fitted by the customer.

For use in environments with hot metal chips or welding splash.

# Rexroth Roller Rail Systems

## General Mounting Instructions

### Parallelism offset of mounted rails (tolerance)

measured on the guide rails and the runner blocks

The parallelism offset  $P_1$  causes a slight rise in the preload on one side.

As long as the values specified in the table are met, the effect of this on the service life can generally be neglected.

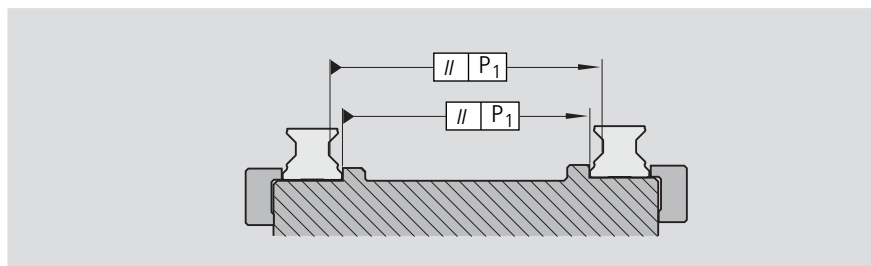

Size	Parallelism offset $P_1$ (mm)	
	0.08 C	0.13 C
25	0.007	0.005
35	0.010	0.007
45	0.012	0.009
55	0.016	0.011
65	0.022	0.016
55/85	0.016	0.011
65/100	0.022	0.016
125	–	0.026

### Vertical offset

Provided the vertical offset is kept within the stated tolerances for  $S_1$  and  $S_2$ , its influence on the service life can generally be neglected.

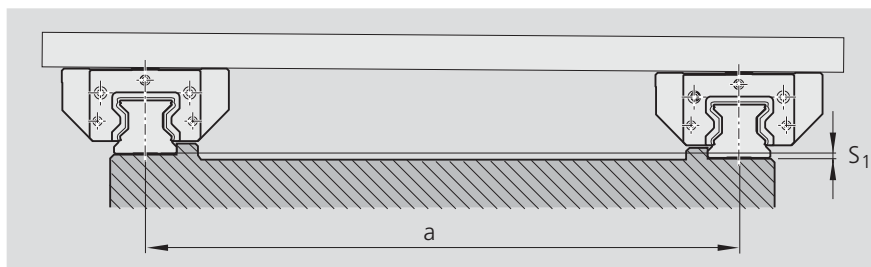

### Permissible vertical offset in transverse direction $S_1$

$$S_1 = a \cdot Y$$

$S_1$  = permissible vertical offset (mm)  
 $a$  = distance between guide rails (mm)  
 $Y$  = calculation factor

Calculation factor	for preload classes	
	Preload 0.08 C	Preload 0.13 C
Y	$1.7 \cdot 10^{-4}$	$1.2 \cdot 10^{-4}$

### Permissible vertical offset in longitudinal direction $S_2$

The permissible vertical offset  $S_2$  includes the tolerance max. difference in dimension  $H$  on the same guide rail, as given in the table on page 29.

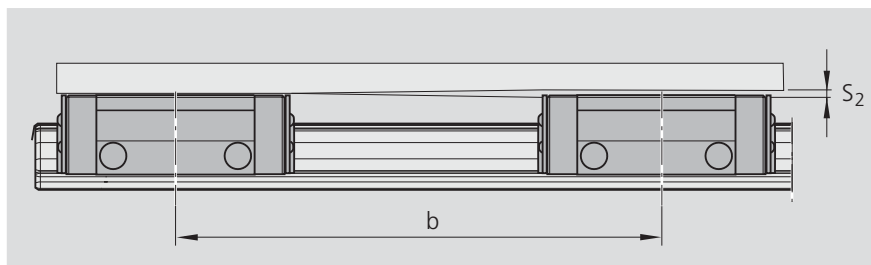

### Runner blocks 1851-, 1821-, 1861-

$$S_2 = b \cdot 4.3 \cdot 10^{-5}$$

### Runner blocks 1853-, 1824-, 1863-, 1872- (long version)

$$S_2 = b \cdot 3.0 \cdot 10^{-5}$$

$S_2$  = permissible vertical offset (mm)  
 $b$  = distance between runner blocks (mm)

## General notes

The following installation notes apply to all Roller Rail Systems.

Rexroth roller rail systems are high quality, precision manufactured products and must therefore be handled with the utmost care in transit and during subsequent installation.

The same care must be taken with cover strips (see the relevant mounting instructions).

All steel parts are treated with anti-corrosion oil prior to shipment. It is not necessary to remove this oil provided the recommended lubricants are used.

## Mounting instructions

### Mounting the guide rails:

Guide rail with lateral retention:

- If a cover strip is fitted, unclip it. (Observe the mounting instructions!)
- Push both rails into contact with the reference edges (1) and tighten the screws lightly.
- Fix the rails in place with retaining strips (2) or wedge profiles (3).
- Apply the specified torque to tighten the guide rail screws.
- Mount the cover strip or the mounting hole plugs. (Observe the mounting instructions!)

### Note

For guide rails without lateral retention, we recommend using a straightedge to make sure the rails are properly aligned and parallel during assembly.

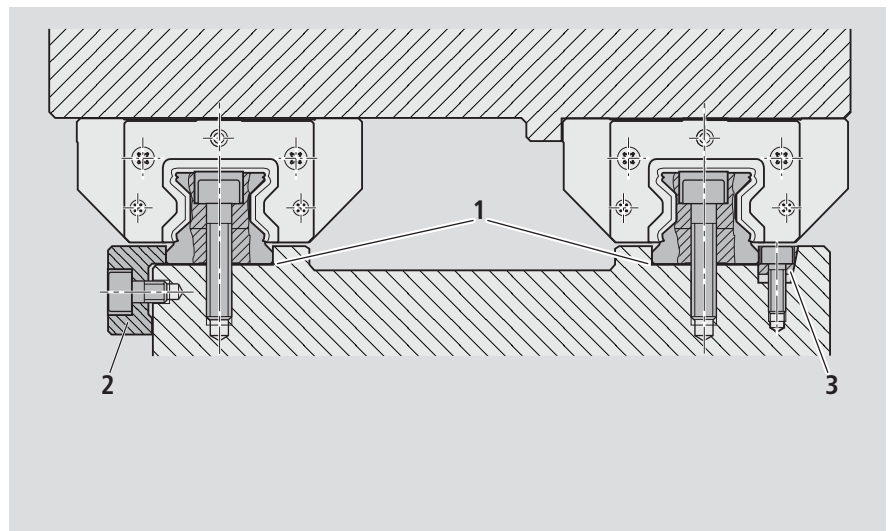

# Rexroth Roller Rail Systems

## General Mounting Instructions

### Mounting the runner block:

**⚠** Before mounting the runner block, oil or grease the bevel on the end face of the guide rail and the sealing lips of the runner block.

- Carefully slide the runner block onto the guide rail.
- Press the runner block on the first rail against the reference edge (1) and screw down.
- Screw down the runner block on the second rail and pin if required.

Do not drill holes for locating pins until after mounting.

If the system has been properly installed, the runner block should slide easily on the rail.

- Now apply the initial lubrication (see chapter "Lubrication").

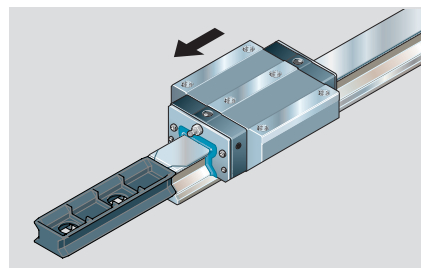
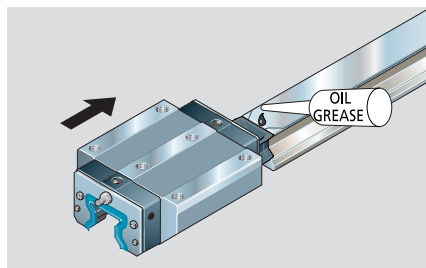
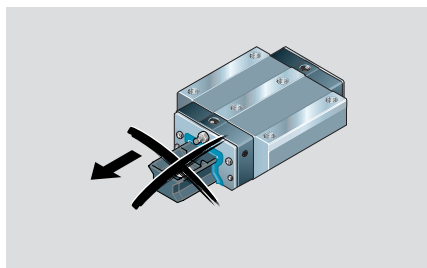
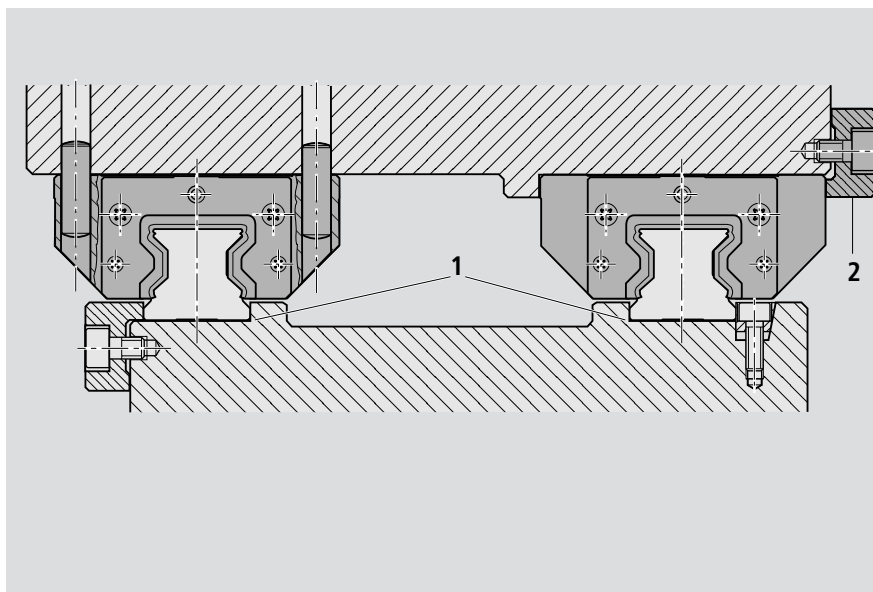

**⚠** Do not remove the transport and mounting arbor from the runner block until the runner is safely on the rail! Otherwise, the rollers may fall out!

**⚠** Use the mounting arbor again to remove runner blocks from the rail! When not installed on the guide rails, the runner blocks should always be kept on the arbor!

### Inserting the mounting hole plugs:

**A** After mounting the guide rails, tap the plastic mounting hole plugs (2) into the screw holes with the aid of a plastic pad (1) until flush with the surface of the rail.

**B** Steel mounting hole plugs: Always use the special mounting tool. The plugs must be flush with the rail surface before mounting the runner block! See mounting instructions.

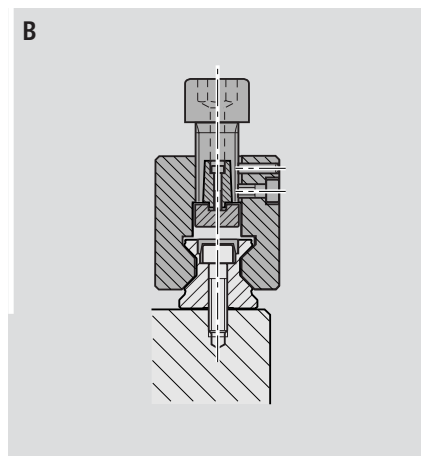
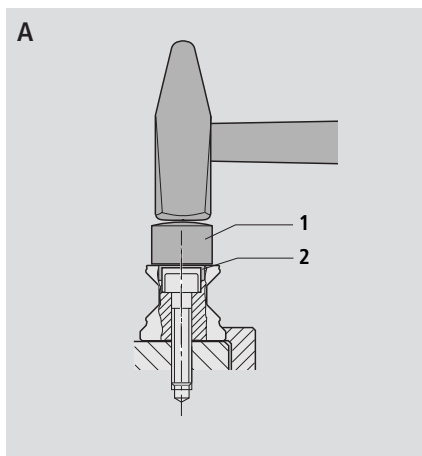

## Load on the screw connections between the guide rail and the mounting base

Rexroth high-performance profiled rail guideways permit the load limits for screw connections as specified in DIN 645-1 to be exceeded. The most critical point is the screw connection between the guide rail and the mounting base. Joints for which the lift-off loads ( $F$ ) or moments ( $M_t$ ) exceed the relevant load limits in the table must be separately recalculated.

The values shown here apply under the following conditions:

- Mounting screw quality 12.9
- Screws tightened with a torque wrench
- Screws lightly oiled (for screws in quality 8.8, an approximation factor of 0.6 can be applied).

Standard roller rail systems					
Guide rail	Size	Runner block			
		1821, 1851		1824, 1853	
		$F_{max}$ (N)	$M_{t max}$ (Nm)	$F_{max}$ (N)	$M_{t max}$ (Nm)
1805	25	34300	360	39200	410
	35	64500	1030	73800	1180
1806	45	157800	3390	180400	3870
1845	55	216800	5400	247800	6100
	65			339400	10100
1807	25	34300	360	39200	410
	35	64500	1030	73800	1180
1847	45	157800	3390	180400	3870
	55	216800	5400	247800	6100
	65			339400	10100

Wide roller rail systems			
Guide rail	Size	Runner block	
		1872	
		$F_{max}$ (N)	$M_{t max}$ (Nm)
1875	55/85	360000	10100
1873	65/100	494000	16500

Heavy duty roller rail systems					
Guide rail	Size	Runner block			
		1861		1863	
		$F_{max}$ (N)	$M_{t max}$ (Nm)	$F_{max}$ (N)	$M_{t max}$ (Nm)
1835	125	1102500	66150	1260000	75600
1865					

Guide rail mounted from above

1805-, 1806-, 1845-, 1835-, 1865-, 1875-, 1873-

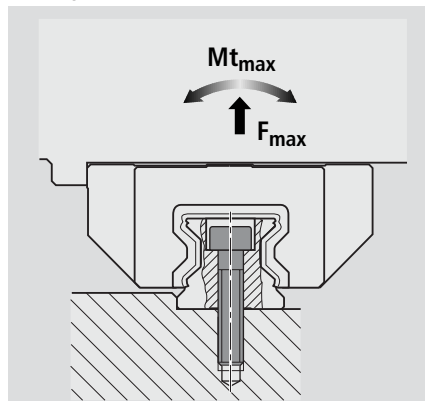

Guide rail mounted from below

1807-, 1847-

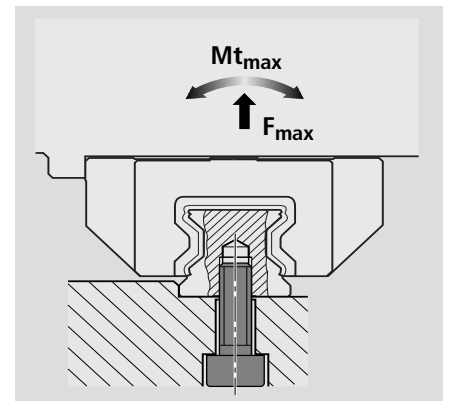

# Rexroth Roller Rail Systems

## Mounting Instructions for the Cover Strip

Detailed information on mounting cover strips can be found in our "Mounting Instructions for the Cover Strip", RDEFI 82 070.

### Advantages of the cover strip

The cover strip is easy to clip on and remove.

- This considerably facilitates and speeds up the mounting process.
- The cover strip can be mounted and removed several times.

The cover strip is a precision-machined part that must be handled with great care. It must on no account be bent.

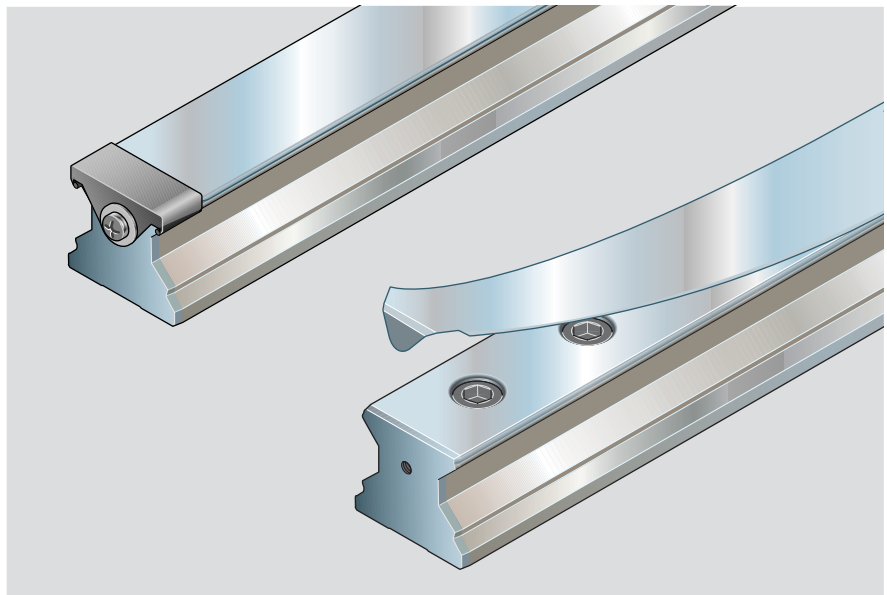

### Versions / functions

#### A Snap-fit cover strip (standard)

- The cover strip is clipped on before the runner block is mounted and fits tightly.

#### B Sliding-fit cover strip

- For mounting or replacing a cover strip when the runner block or superstructure cannot be removed.
- A section of the snap-fit cover strip is very slightly widened and can then be easily slid under the runner block.

Observe the detailed mounting instructions.

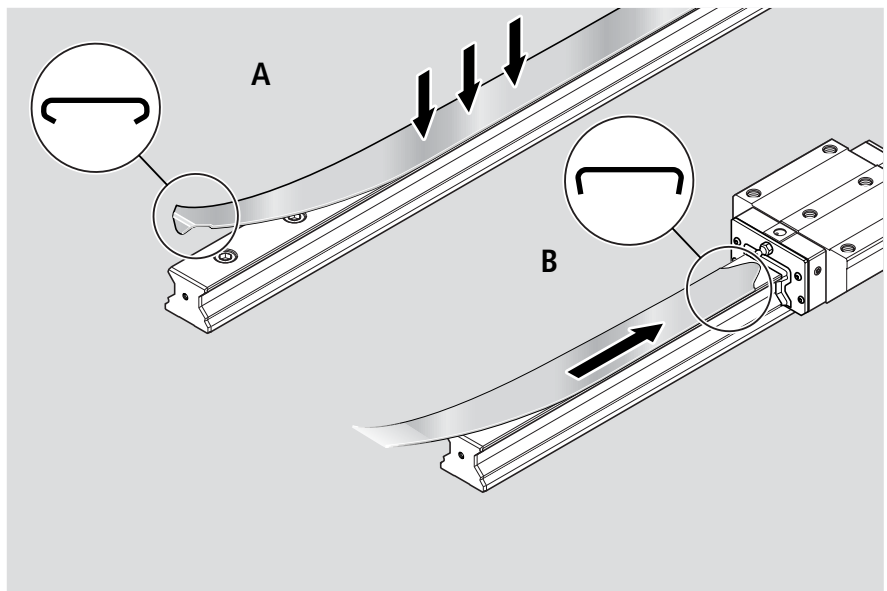

A special expanding tool for cover strips can be used to create the sliding fit after installation in order to be able to remove a cover strip.

The main advantage is that the length **X** of the sliding fit can be optimized to suit the installation conditions.

Observe the detailed mounting instructions!

For part numbers see sections "Cover strip, Protective caps, Mounting hole plugs".

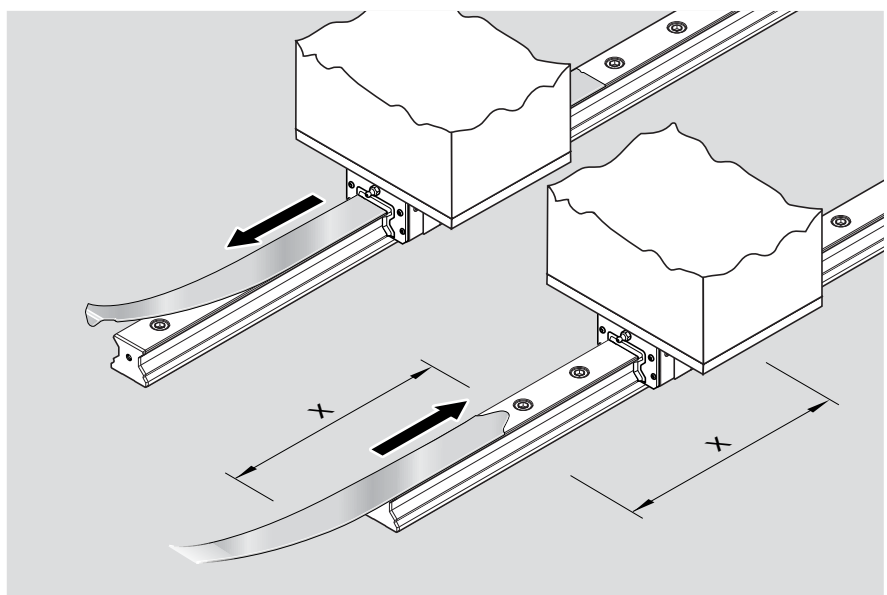



## Shipment

### For one-piece guide rails:

Standard: One-piece roller guide rails are shipped with the cover strip clipped on, both ends angled down and with protective caps screwed on.

If required, guide rails can also be supplied with a separate cover strip.

### For composite guide rails:

A one-piece cover strip to cover the total length is supplied, together with the protective caps and matching screws and washers, in a separate packing unit. The packing unit is marked with the same manufacturing job number as the labels on the guide rails. The cover strips have one angled-down and one straight end (strip tongue).

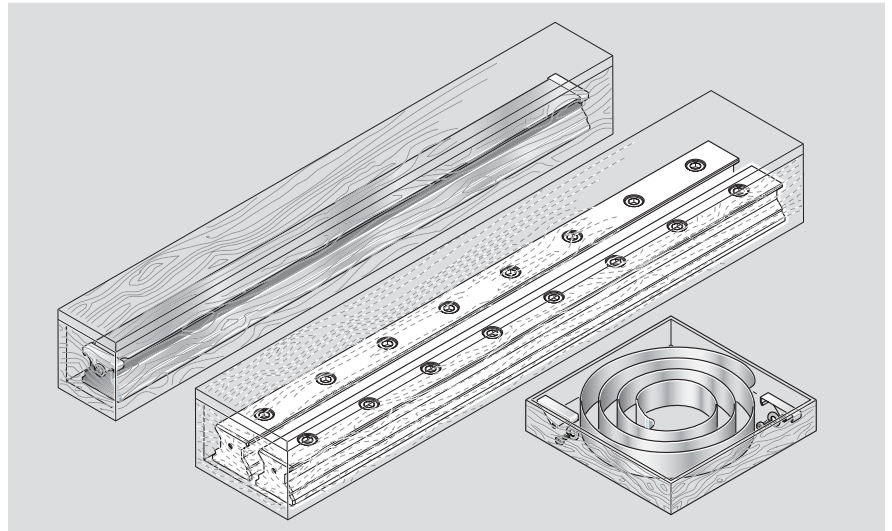

## Securing the cover strip

The following options are available for securing the cover strip:

- Protective cap
- Screw and washer
- Strip clamp (new)
- For further cover strip securing options see "Mounting Instructions for the Cover Strip" RDEFI 82 070.

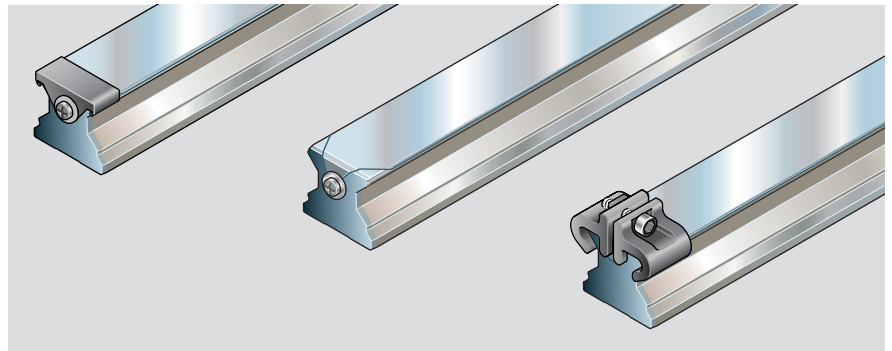

**⚠** Limit the stroke to ensure the runner block will not run right to the rail end (bevel cut of the cover strip), otherwise the seals could be damaged.

- Observe dimension  $L_5$  (minimum distance from the rail end)!

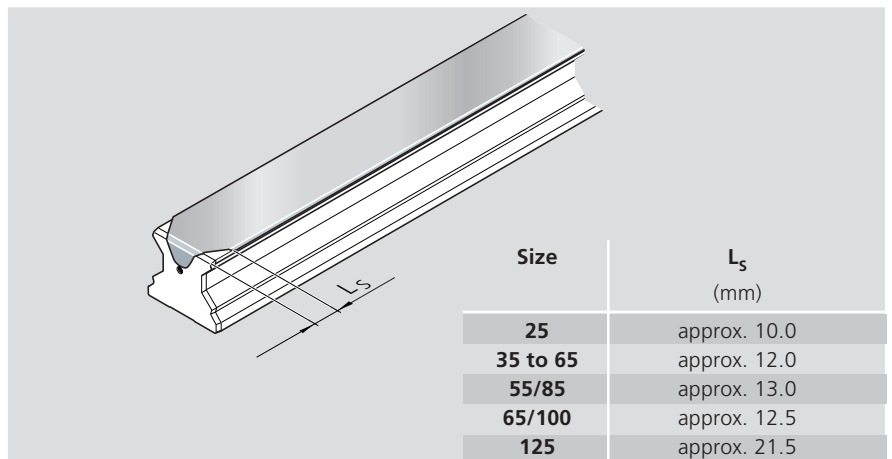

## Mounting kit for the cover strip

The mounting kit contains a mounting tool (A) as well as a lift-off plate (B) for removing the cover strip.

New: Mounting kits are now also available for wide and heavy duty guide rails.

For more detailed information and part number see section "Accessories for Guide Rails".

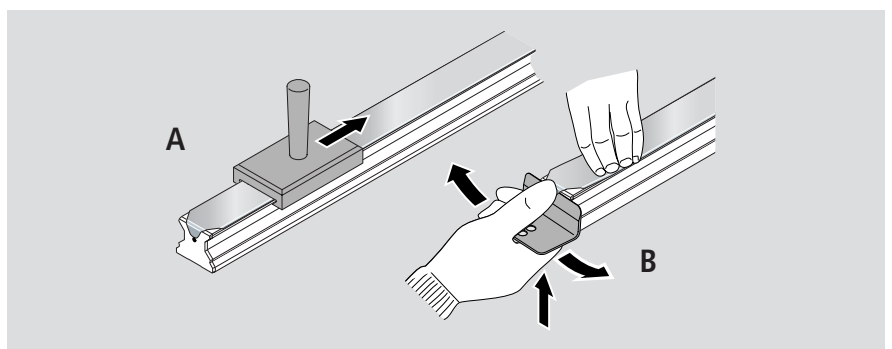

# Rexroth Roller Rail Systems

## Product Overview – Standard Steel Runner Blocks

Rexroth Roller Rail Systems were specially developed for use in machine tools and industrial robots calling for compact, rolling-element linear motion guideways. They are available in various accuracy classes, each with extremely high load capacity and high rigidity.

These space-saving assemblies in 5 common sizes afford the same high load capacities in all four major planes of load application.

### **Make up your own compact linear motion guideways from interchangeable standard stock elements...**

Rexroth fabricates its guide rails and runner blocks with such high precision that each individual component element can be replaced by another at any time. This makes infinite combinations possible. Each element can be individually ordered and separately stocked.

Both sides of the guide rail can be used as reference edges.

Accessories can be simply attached to the ends of the runner block.

- Uniform guide rail profile with or without cover strip allows unrestricted interchangeability of components across all runner block variants.
- Lube ports on all sides for maximum ease of maintenance.
- Novel lube duct design minimizes lubricant consumption.
- Innovative cage design allows for longer lubrication intervals.
- Smooth running thanks to optimized roller recirculation and guidance.
- Mounting of attachments to runner block from above or below.
- Improved rigidity under lift-off and side loading conditions through additional mounting screw holes at the center of the runner block.
- Optimized entry-section geometry and high number of rollers per track minimizes variation in elastic deflection.
- The roller block simply slides off its arbor and onto the rail.

For all applications:

### **Standard Roller Rail Systems**

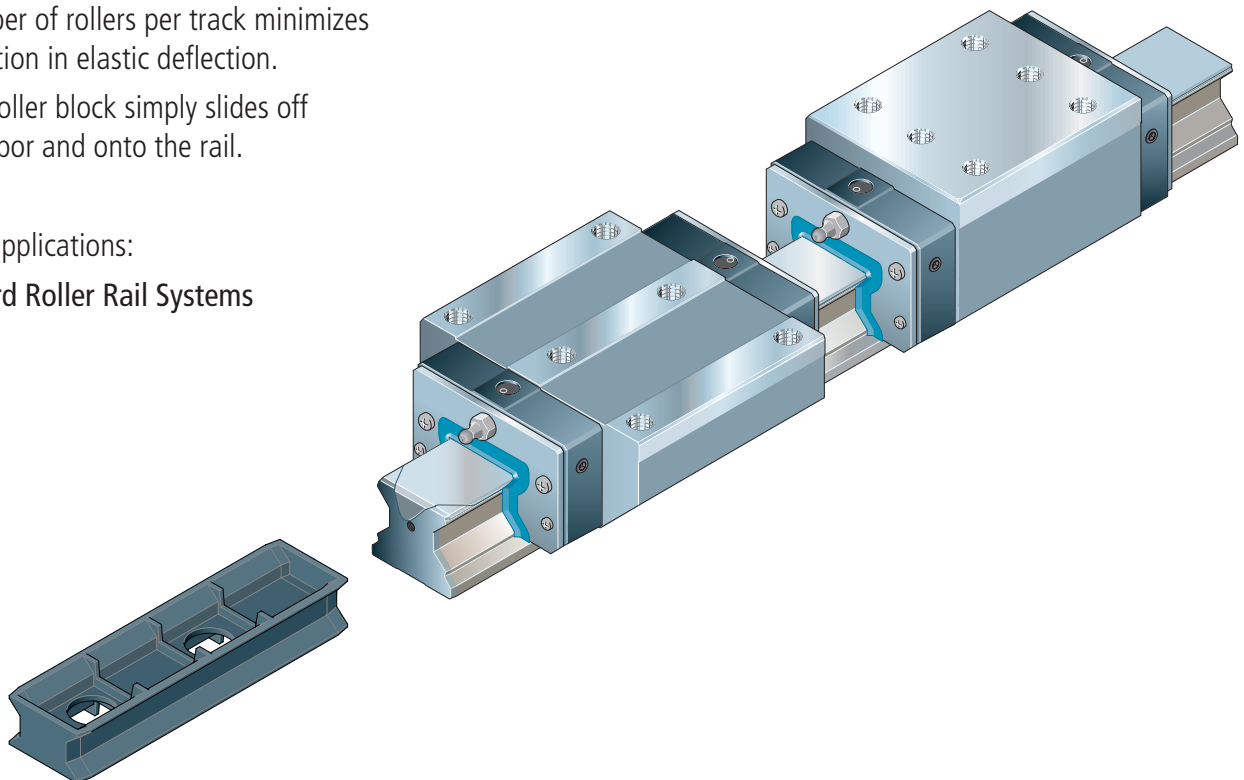

- Maximum rigidity under load from all directions
  - High torque capacity
  - Integrated all-round sealing
  - End seal as standard
- 
- Runner blocks in accuracy class H (preload 0.08 C) also available with surface protection:
    - hard chrome-plated

For special applications  
and environments:

**Standard steel runner block  
for wall mounting**

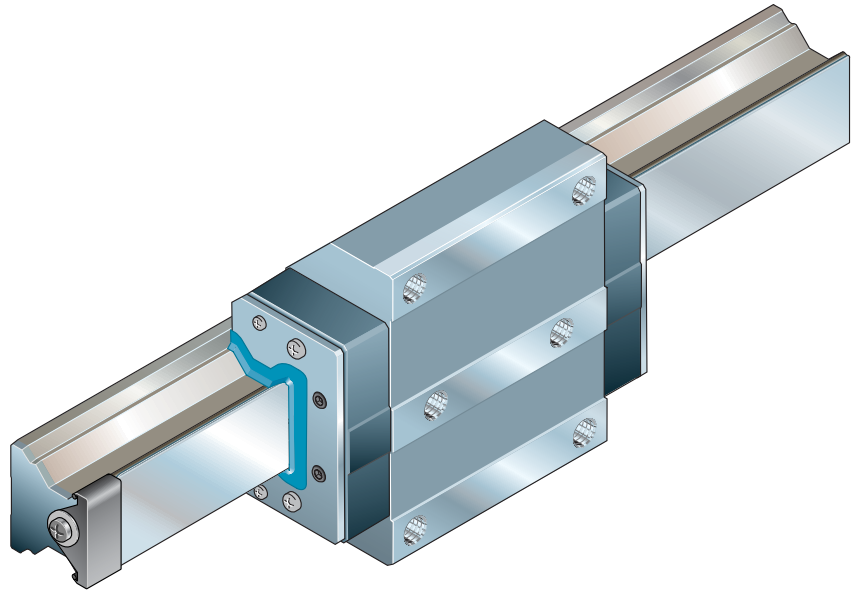

**NEW**

For hostile environments:

**Standard steel runner block  
with aluminum end caps**

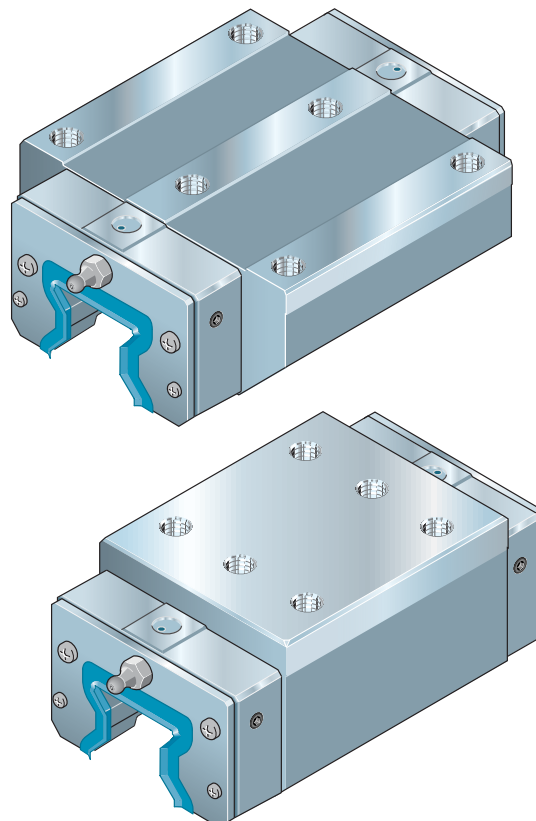

# Rexroth Roller Rail Systems

## Product Description – Standard Steel Runner Blocks

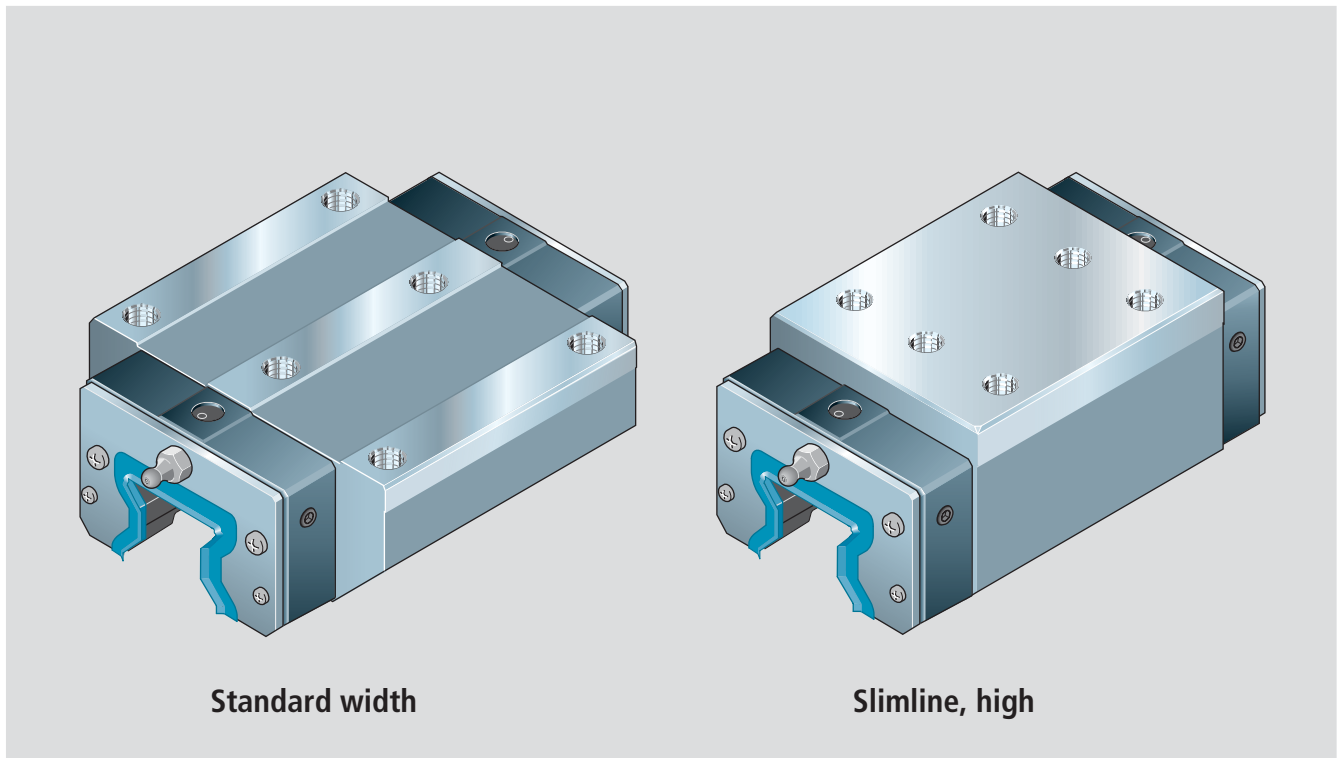

### The Roller Rail Systems consist of:

- guide rail, all surfaces ground, hardened bearing surfaces
- runner block of anti-friction bearing steel, hardened and ground raceways, with:
  - rollers made of anti-friction bearing steel
  - cage designed for optimum roller recirculation
  - fully sealed roller raceways
  - two end seals for better sealing and to protect plastic parts.

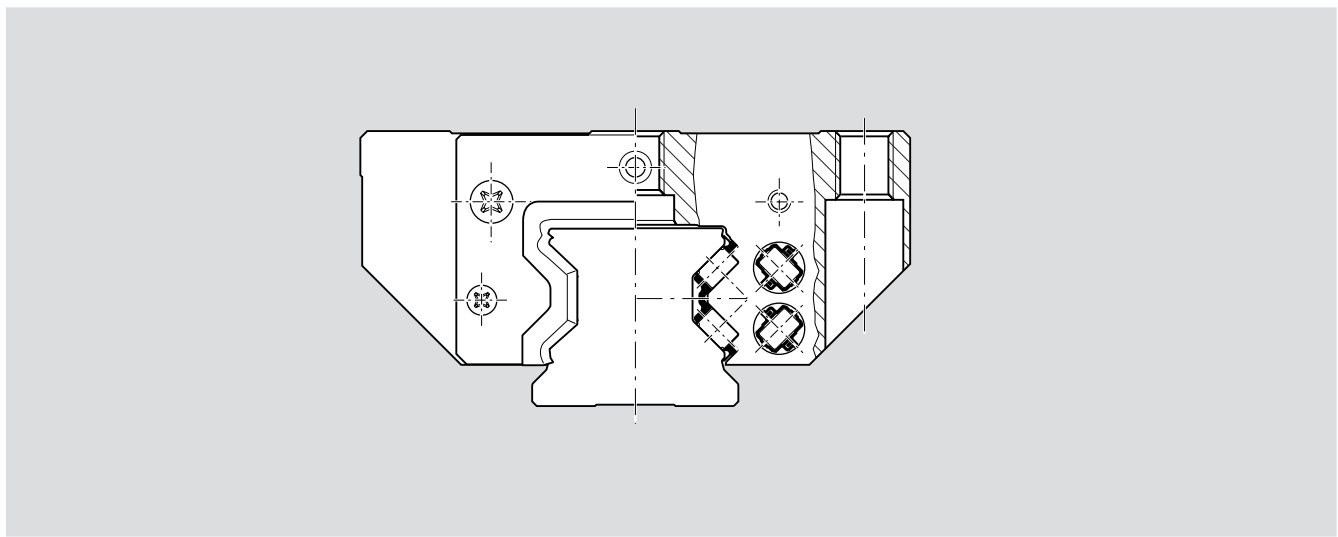

# Technical Data – Standard Steel Runner Blocks

## Accuracy classes and their tolerances

Rexroth Roller Rail Systems are available in up to 4 different accuracy classes.

For available versions see “Part number” tables.

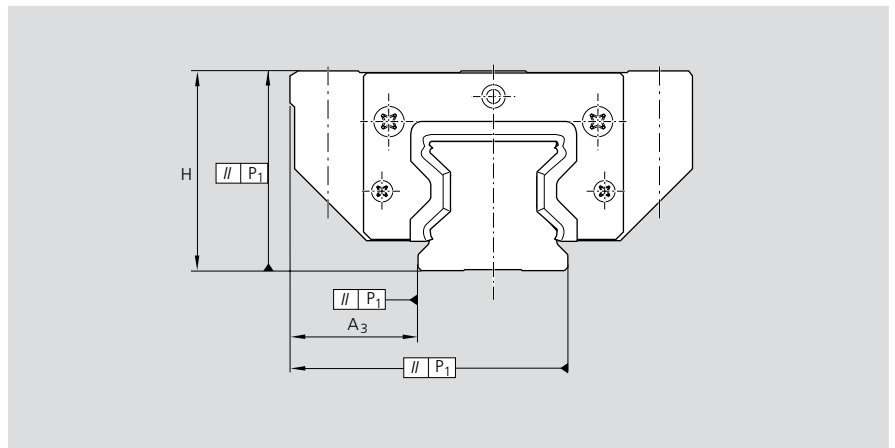

## Built-in interchangeability due to precision machining

Rexroth machines its guide rails and runner blocks, and the roller raceways in particular, with such high precision that each individual element is interchangeable.

Any runner block can be combined with any guide rail of the same size. It is also possible to install several different runner blocks on the same guide rail.

## Standard steel runner blocks

Accuracy classes	Dimensional tolerances (µm)		Max. difference in dimensions H and A <sub>3</sub> on the same guide rail Δ H, Δ A <sub>3</sub> (µm)
	H	A <sub>3</sub>	
UP	± 5	± 5	3
SP	± 10	± 7	5
P	± 20	± 10	7
H	± 40	± 20	15

## Special versions: hard chrome-plated

	H		A <sub>3</sub>		Δ H, Δ A <sub>3</sub> (µm)	
	RB/GR	GR	RB/GR	GR	RB/GR	GR
SP	+ 17 - 8	+14 - 9	± 10	+ 6 - 11	8	5
P	+ 27 - 18	+ 24 - 19	± 13	+9 -14	10	7
H	+ 47 - 38	+ 44 - 39	± 23	+ 19 - 24	18	15

## Abbreviations

RB/GR = runner block and guide rail  
hard chrome-plated  
GR = only the guide rail is hard chrome-plated

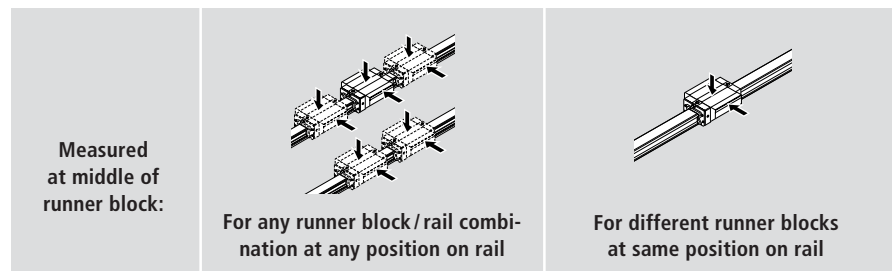

## Parallelism offset P<sub>1</sub> of Roller Rail Systems when properly installed

### Measured at middle of runner block

Values apply to roller rail systems without surface coating.

With hard chrome-plated guide rails, the values may increase by up to 2 µm.

## Legend

P<sub>1</sub> = parallelism offset  
L = rail length

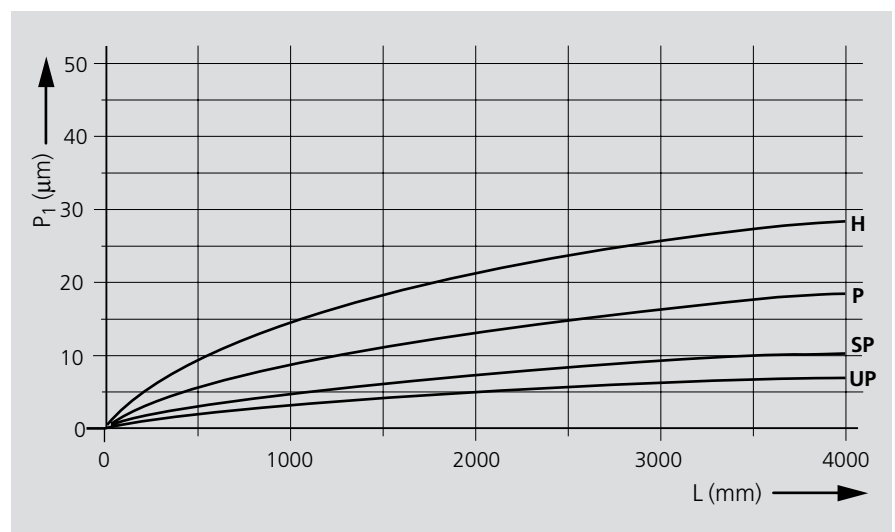

# Rexroth Roller Rail Systems

## Technical Data – Standard Steel Runner Blocks

### Rigidity of the Roller Rail System at 0.08 C preload

Runner block 1851-  
Standard width  
(sizes 25 to 65)

————— measured values

Runner block mounted using  
6 screws:

- 4 outer screws of strength class 12.9
- 2 centerline screws of strength class 8.8

#### 1. Down load

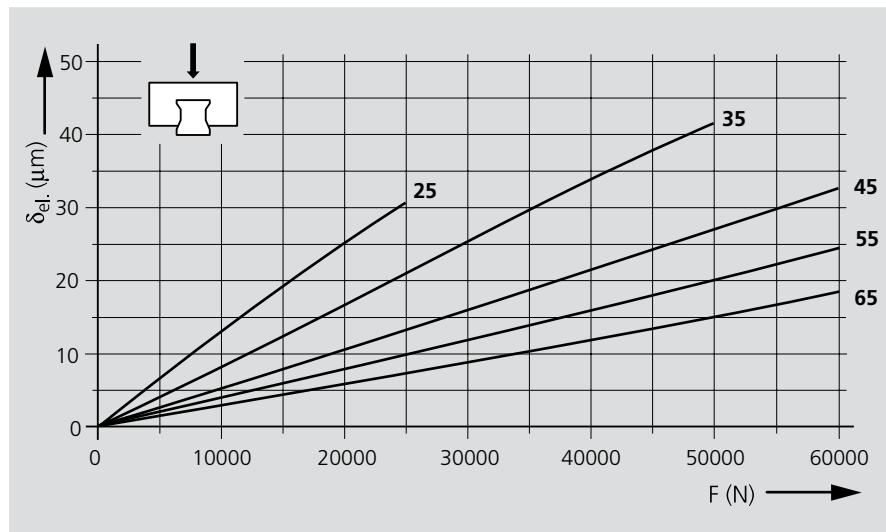

#### 2. Lift-off load

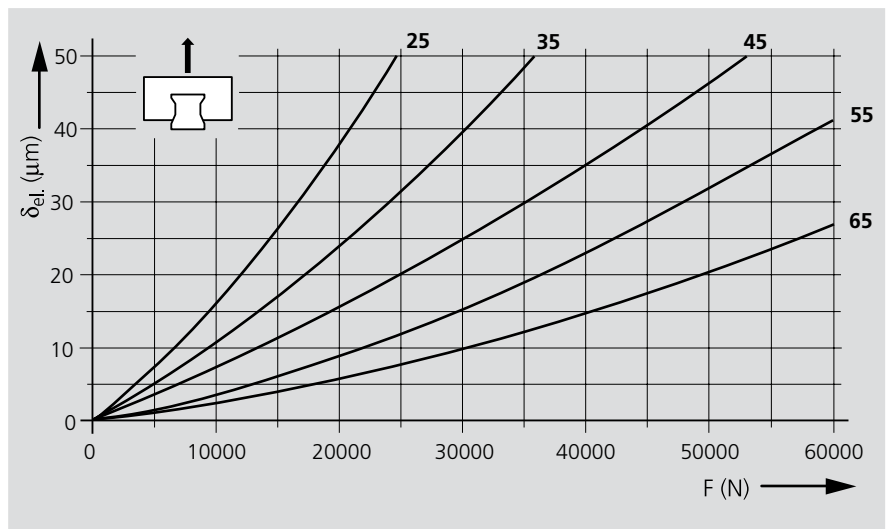

#### 3. Side load

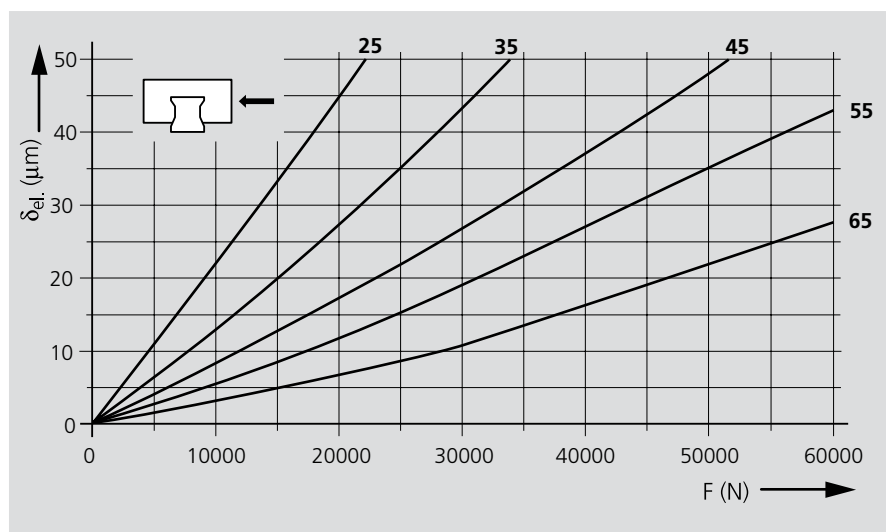

#### Legend

δ<sub>el.</sub> = elastic deflection  
F = load

## Rigidity of the Roller Rail System at 0.13 C preload

Runner block 1851-  
Standard width  
(sizes 25 to 65)

————— measured values

Runner block mounted using  
6 screws:

- 4 outer screws of strength class 12.9
- 2 centerline screws of strength class 8.8

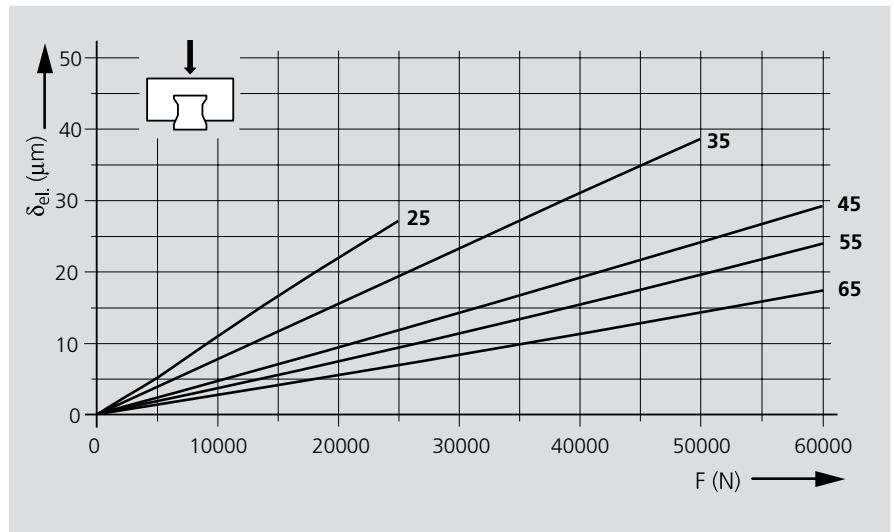

### 1. Down load

### 2. Lift-off load

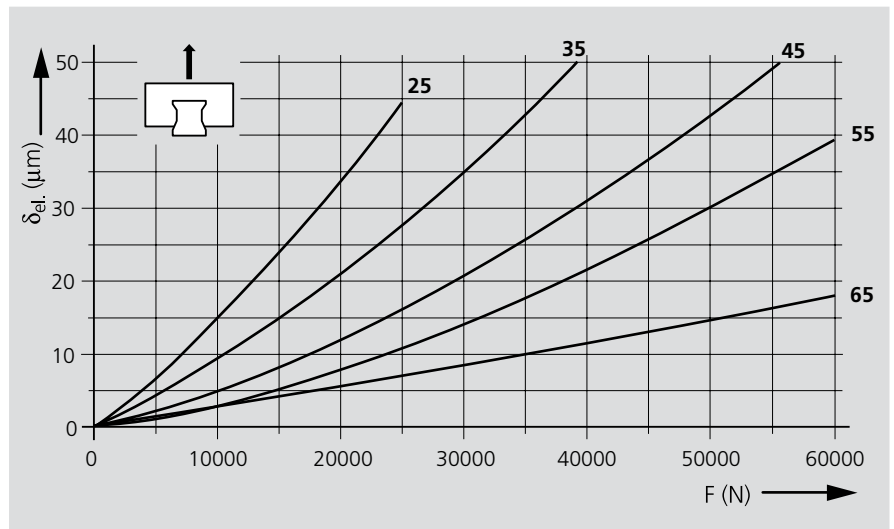

### 3. Side load

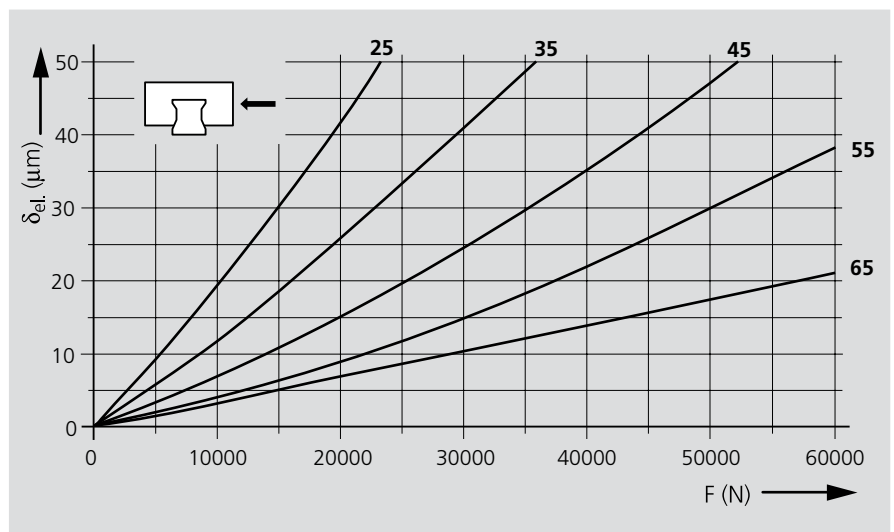

#### Legend

$\delta_{el.}$  = elastic deflection

F = load

# Rexroth Roller Rail Systems

## Technical Data – Standard Steel Runner Blocks

### Rigidity of the Roller Rail System at 0.08 C preload

Runner block 1853-  
Standard width, long  
(sizes 25 to 65)

————— measured values

Runner block mounted using  
6 screws:

- 4 outer screws of strength class 12.9
- 2 centerline screws of strength class 8.8

#### 1. Down load

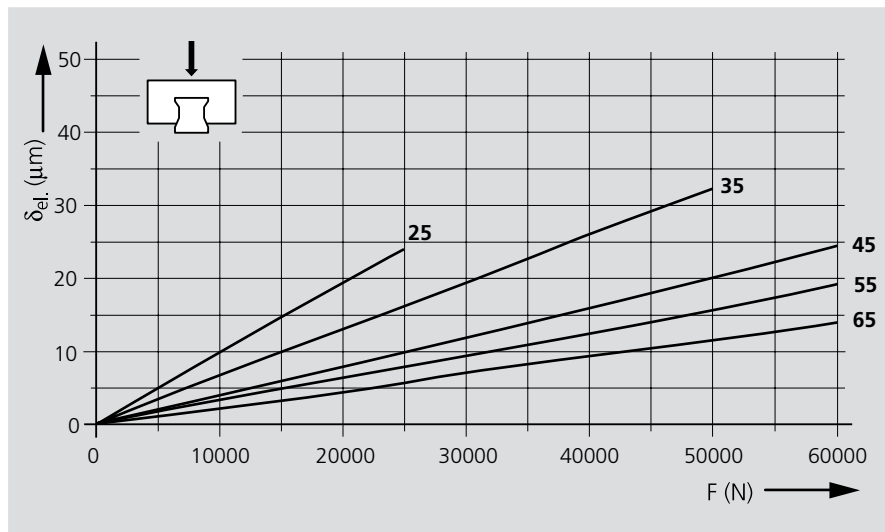

#### 2. Lift-off load

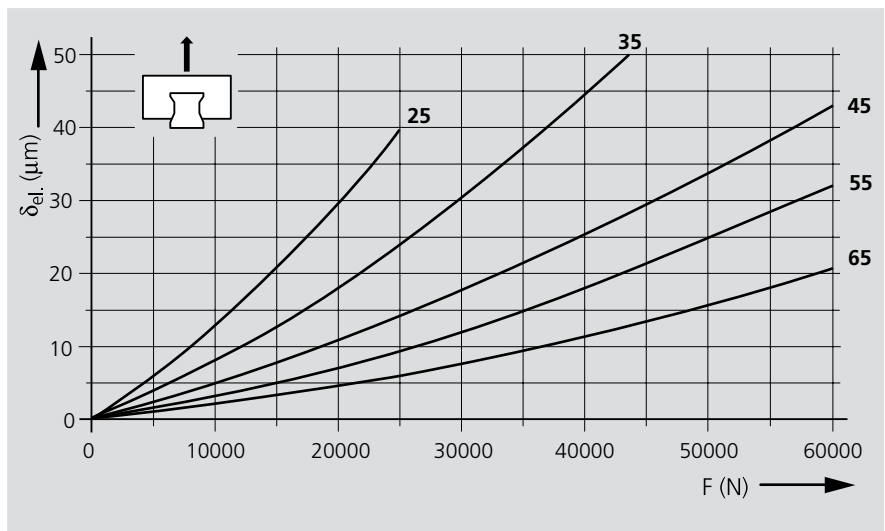

#### 3. Side load

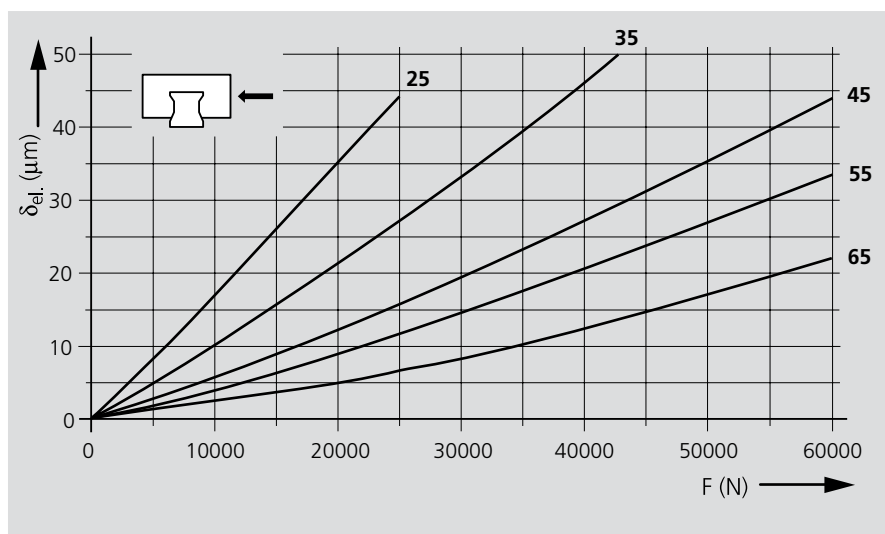

#### Legend

δ<sub>el.</sub> = elastic deflection

F = load



## Rigidity of the Roller Rail System at 0.13 C preload

Runner block 1853-  
Standard width, long  
(sizes 25 to 65)

————— measured values

Runner block mounted using  
6 screws:

- 4 outer screws of strength class 12.9
- 2 centerline screws of strength class 8.8

### 1. Down load

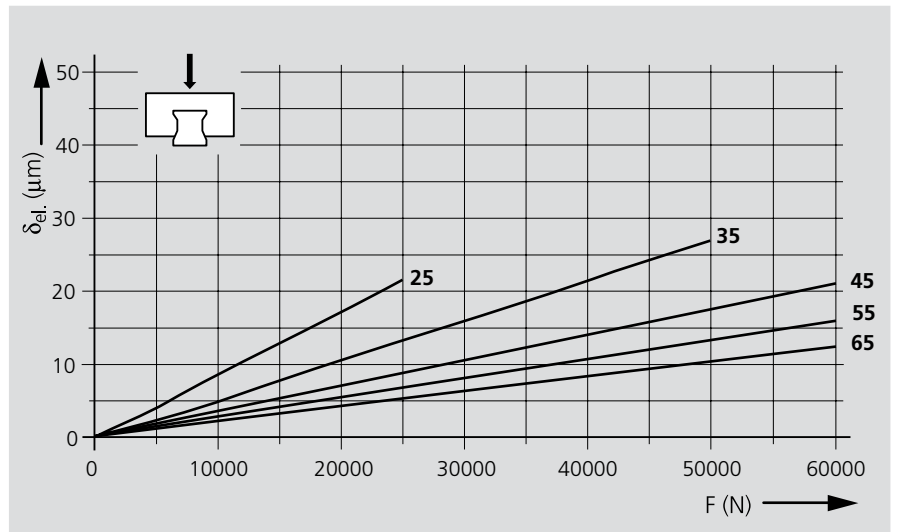

### 2. Lift-off load

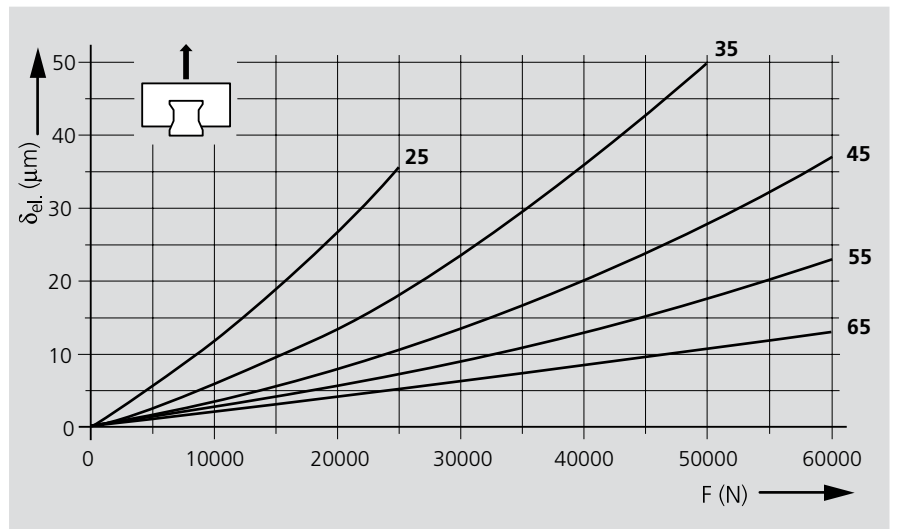

### 3. Side load

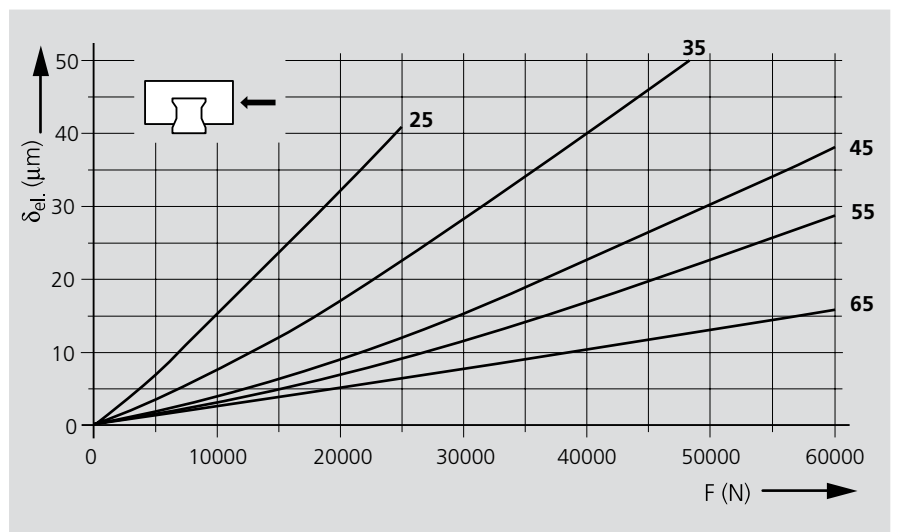

#### Legend

$\delta_{el.}$  = elastic deflection

F = load

# Rexroth Roller Rail Systems

## Technical Data – Standard Steel Runner Blocks

Rigidity of the Roller Rail System at 0.08 C preload

Runner block 1821-Slimline, high (sizes 25 to 55)

————— measured values

Runner block mounted using 6 screws of strength class 12.9

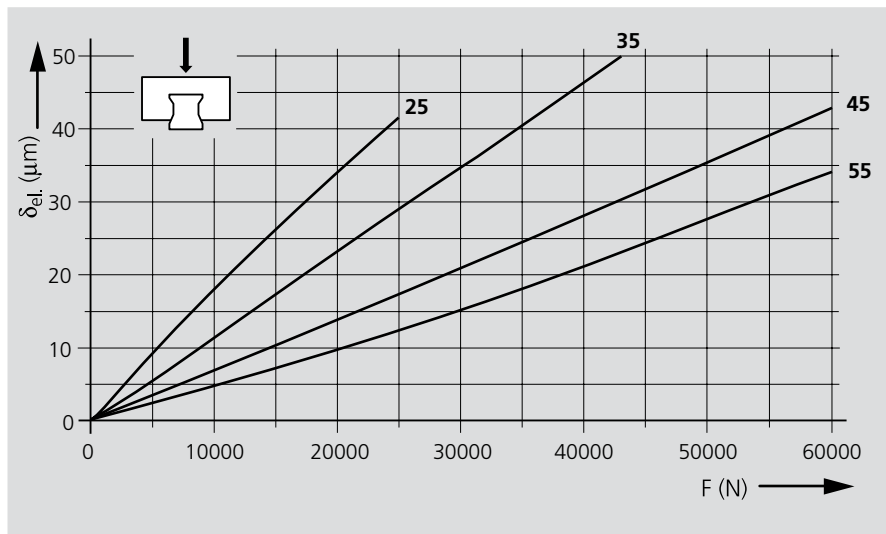

1. Down load

2. Lift-off load

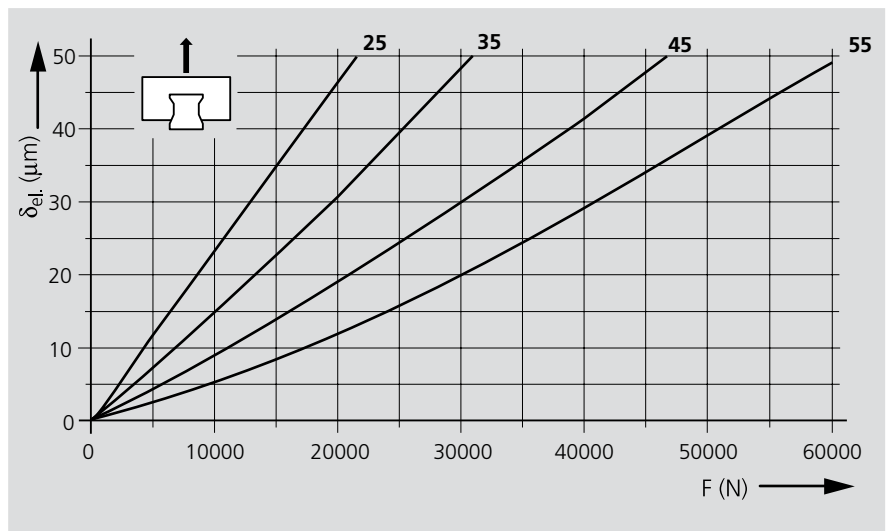

3. Side load

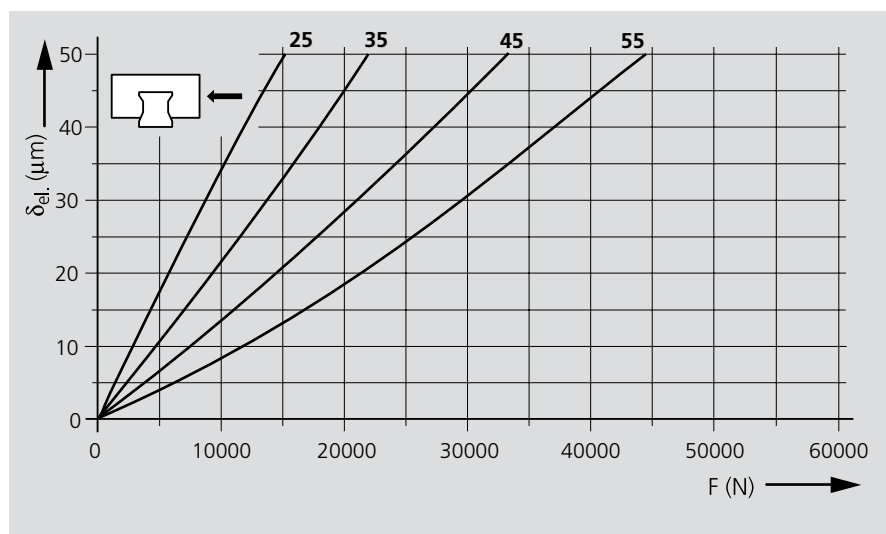

### Legend

δ<sub>el.</sub> = elastic deflection

F = load

## Rigidity of the Roller Rail System at 0.13 C preload

Runner block 1821-  
Slimline, high  
(sizes 25 to 55)

————— measured values

Runner block mounted using  
6 screws of strength class 12.9

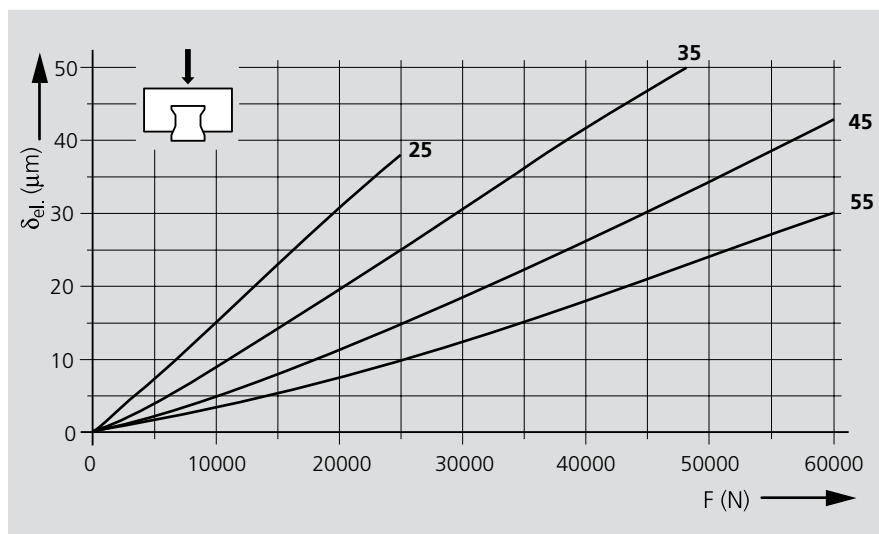

### 1. Down load

### 2. Lift-off load

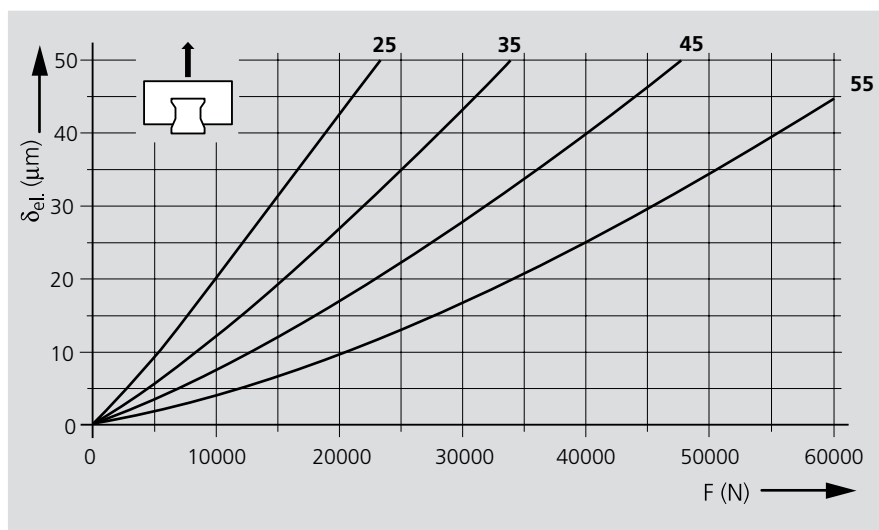

### 3. Side load

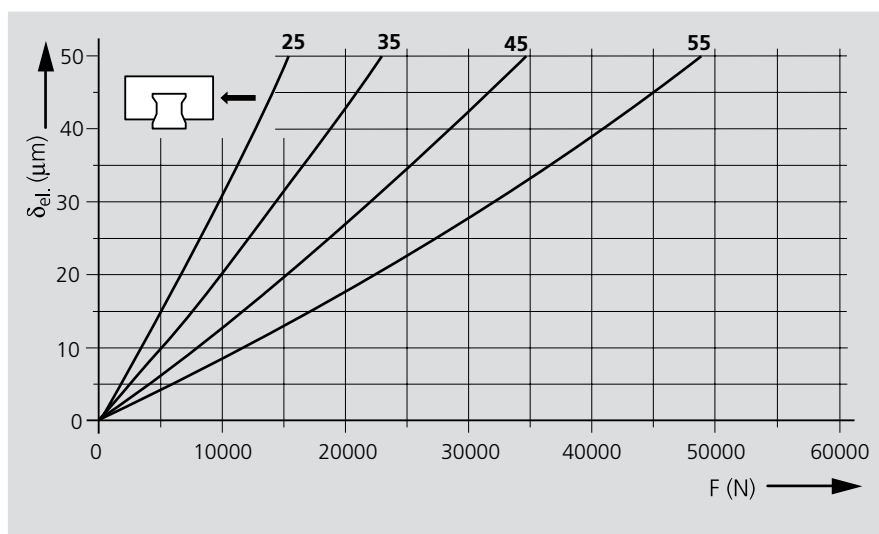

#### Legend

$\delta_{el.}$  = elastic deflection

F = load

# Rexroth Roller Rail Systems

## Technical Data – Standard Steel Runner Blocks

Rigidity of the Roller Rail System at 0.08 C preload

Runner block 1824-Slimline, high, long (sizes 25 to 65)

————— measured values

Runner block mounted using 6 screws of strength class 12.9

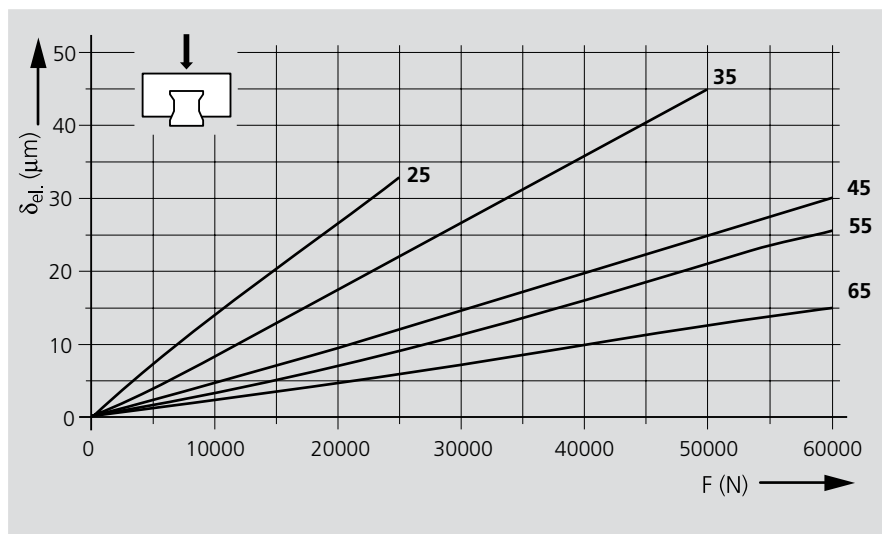

1. Down load

2. Lift-off load

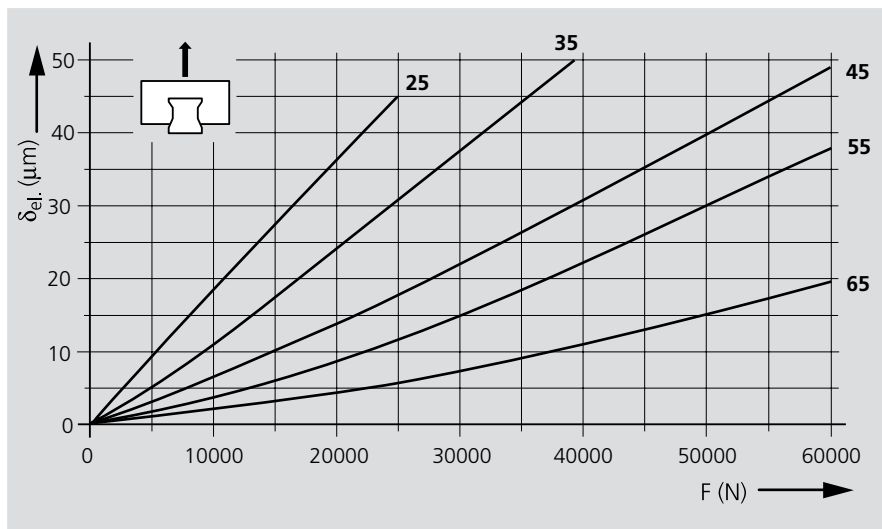

3. Side load

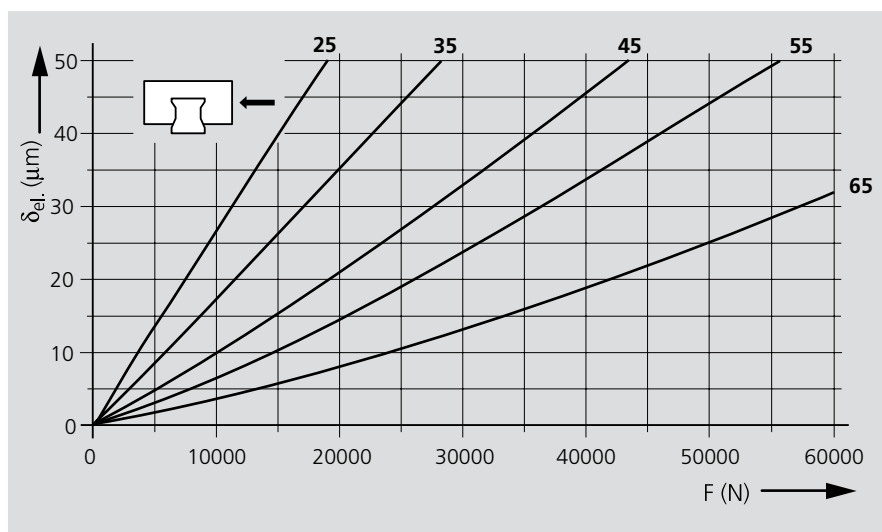

### Legend

$\delta_{el.}$  = elastic deflection

F = load

## Rigidity of the Roller Rail System at 0.13 C preload

Runner block 1824-  
Slimline, high, long  
(Sizes 25 to 65)

————— measured values

Runner block mounted using  
6 screws of strength class 12.9

### 1. Down load

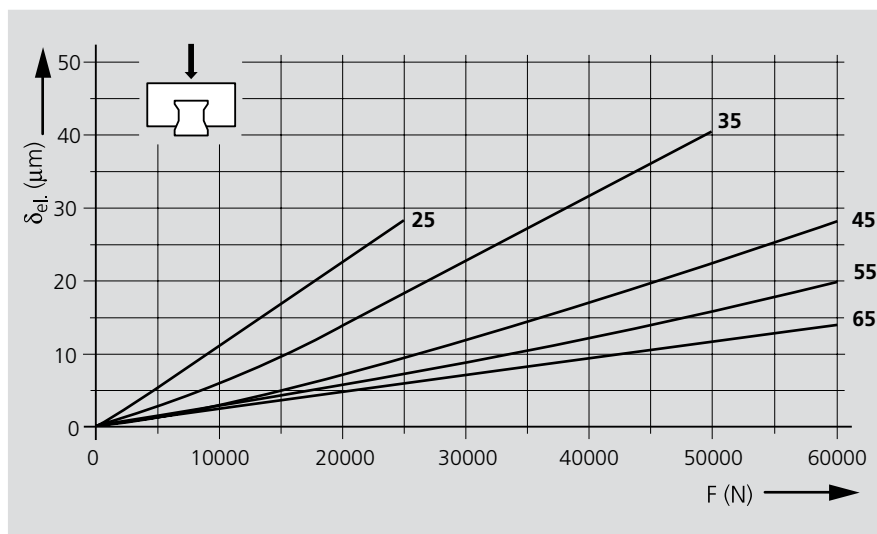

### 2. Lift-off load

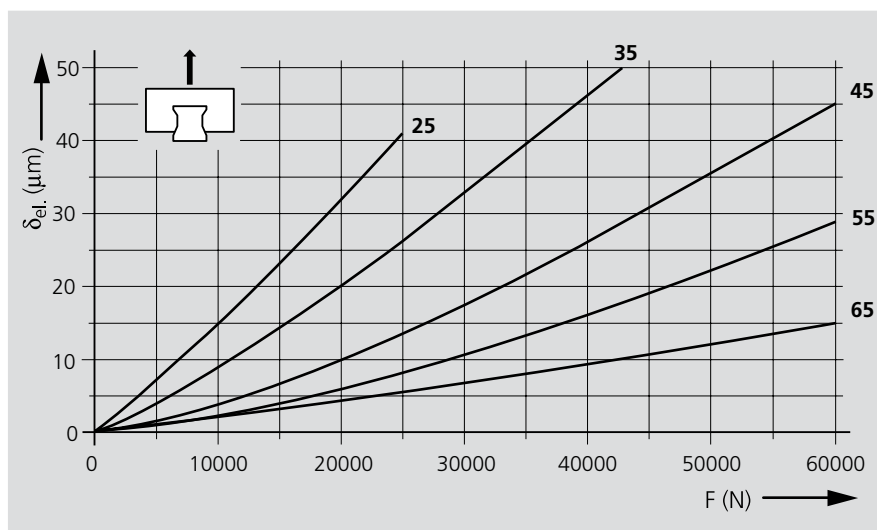

### 3. Side load

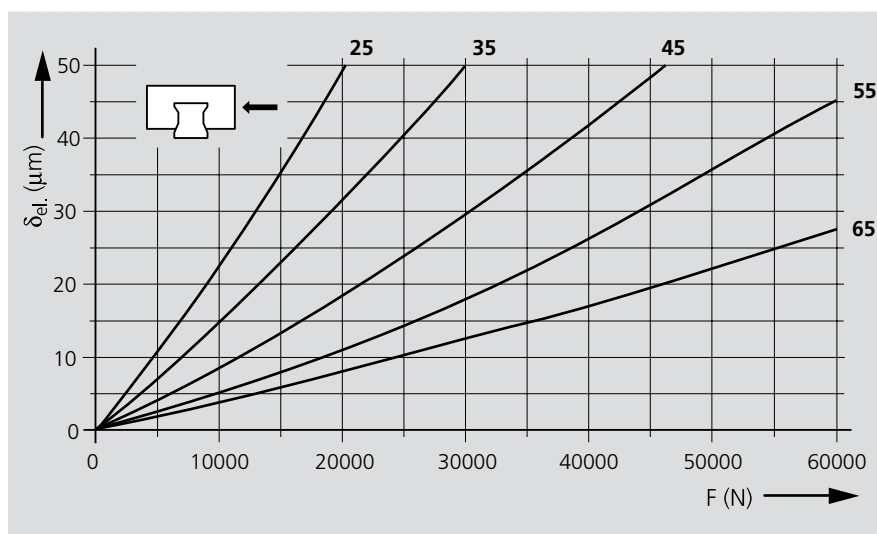

#### Legend

δ<sub>el.</sub> = elastic deflection

F = load

# Rexroth Roller Rail Systems

## Mounting Instructions for Standard Roller Rail Systems

### Reference edges, corner radii, screw sizes and tightening torques

#### Note

The indicated combinations represent examples. Basically, any runner block may be combined with any of the rail types offered.

The recommended limits for permissible side loads **without additional lateral retention** indicate the approximate upper limits for screws in two strength classes. In other cases, the permissible side load must be calculated from the screw tension force. This can be up to about 15% less when using screws in strength class 10.9 instead of 12.9.

**⚠** Always check the strength factor of the screws in the case of high lift-off loads!

See "Load on the screw connections between the guide rail and the mounting base".

### Dimensions and recommended limits for permissible side loads if no additional lateral retention is provided

- 1) For runner block mounting from above with only 4  $O_4$  screws:
  - Permissible side load 1/3 lower
  - Lower rigidity
- 2) For runner block mounting with 6 screws:
  - Tighten the centerline screws with the torque for strength class 8.8
- 3) For mounting with 2  $O_2$  screws and 4  $O_1$  screws
- 4) Calculated with friction coefficient  $\mu = 0.12$
- 5) If clamping and braking units are used, the  $H_1$  values from the "Clamping and Braking Units" catalog apply.

\* Runner blocks 1821-, 1851-

\*\*Runner blocks 1824-, 1853-

### Tightening torques for mounting screws

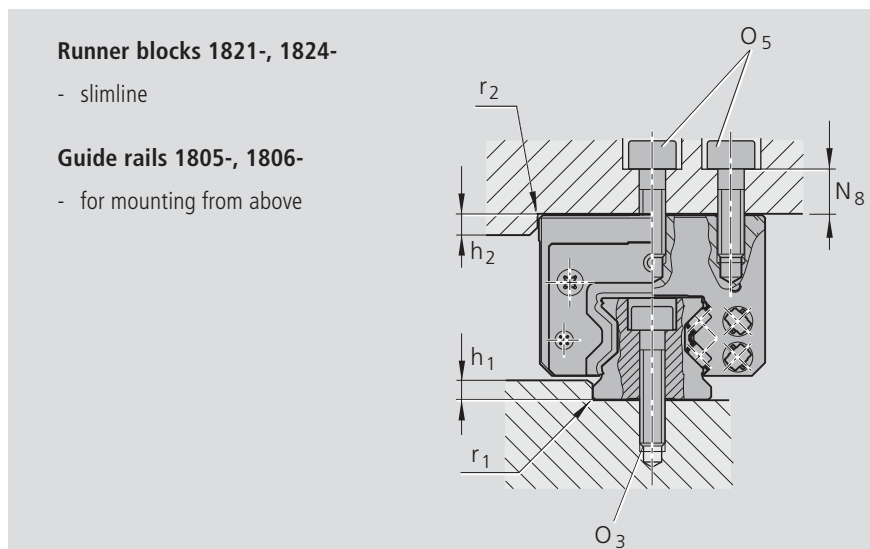
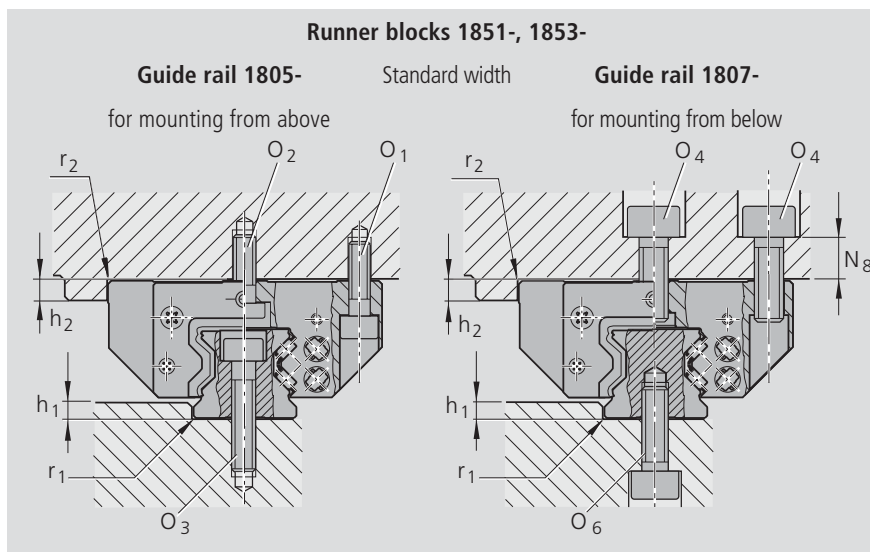

Size	$h_1$		$r_1$	$h_2$		$r_2$	$O_1$	$O_2^{2)}$	$O_4^{1)2)}$	$O_5$	$O_3$	$O_6$	$N_8$
	min. (mm)	max. <sup>5)</sup> (mm)		max. (mm)	max. (mm)								
25	3.0	4.5	0.8	5	0.8	M6x20	M6x16	M8x20	M6x18	M6x30	M6x20		10
35	3.5	5.0	0.8	6	0.8	M8x25	M8x20	M10x25	M8x25	M8x35	M8x25		13
45	4.5	7.0	0.8	8	0.8	M10x30	M10x25	M12x30	M10x30	M12x45	M12x30		14
55	7.0	9.0	1.2	10	1.0	M12x40	M12x30	M14x40	M12x35	M14x50	M14x40		20
65	7.0	9.0	1.2	14	1.0	M14x45	M14x35	M16x45	M16x40	M16x60	M16x45		22

Screw strength class	Permissible side load if no lateral retention is provided <sup>4)</sup>					
	Runner block			Rail		
8.8	*	0.09 C	0.13 C <sup>3)</sup>	0.20 C	0.13 C	0.10 C
12.9	*	0.15 C	0.19 C <sup>3)</sup>	0.30 C	0.22 C	0.17 C
8.8	**	0.07 C	0.11 C <sup>3)</sup>	0.16 C	0.11 C	0.07 C
12.9	**	0.12 C	0.16 C <sup>3)</sup>	0.23 C	0.18 C	0.12 C

	M6	M8	M10	M12	M14	M16
8.8	9.5	23	46	80	125	195
10.9	13.0	32	64	110	180	275
12.9	16.0	39	77	135	215	330

## Locating pins

If the recommended limits for permissible side loads are exceeded, the runner block must be additionally fixed.

### Possible pin types:

- Taper pin (hardened) or
- Straight pin ISO 8734

### Notes

Rough-drilled holes made for production reasons may exist at the recommended pin hole positions on the runner block center-line (dia.  $< S_{10}$ ).

These may be bored open to accommodate the locating pins.

If the locating pins have to be driven in at another point, dimension  $E_2$  must not be exceeded in the longitudinal direction (for dimension  $E_2$ , see the tables for the individual runner block types).

Observe dimensions  $E_1$  and  $E_4$ !

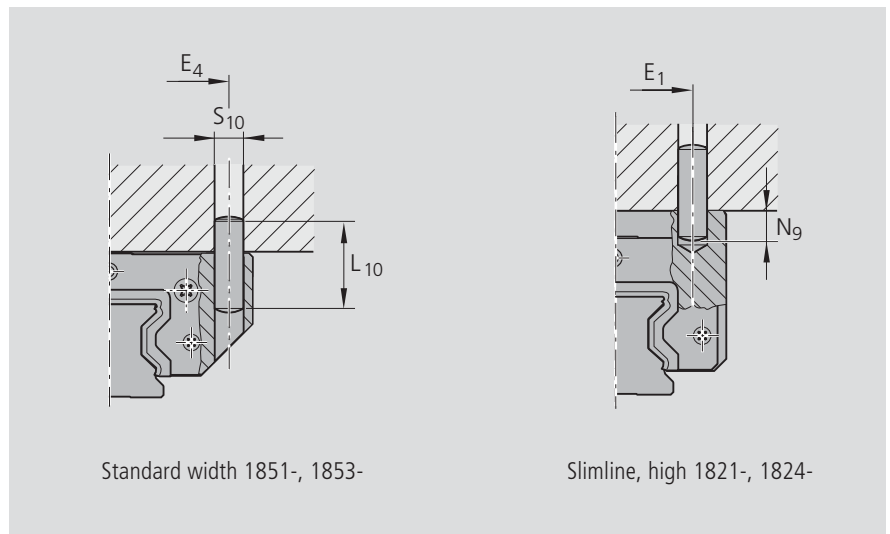

Size	Dimensions (mm)				
	Taper pin (hardened) or straight pin (ISO 8734)		$E_1$	$E_4$	$N_9$ (max)
$S_{10}$	$L_{10}$				
25	6	32	35	55	9
35	8	40	50	80	13
45	10	50	60	98	18
55	12	60	75	114	19
65	14	60	76	140	22

## Instructions for mounting composite rails

### Rails made up of two sections

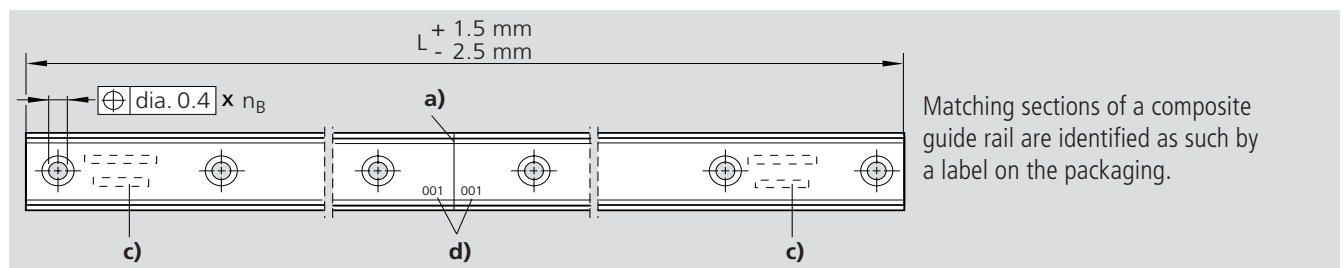

Matching sections of a composite guide rail are identified as such by a label on the packaging.

### Rails made up of three or more sections

All sections of the same rail have the same number, which is marked on the top of the guide rail.

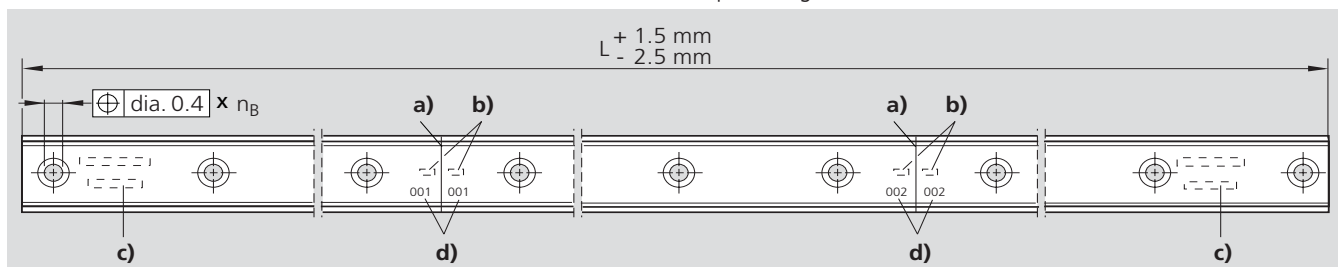

$n_B$  = number of holes

- a) Joint
- b) Rail number
- c) Full rail identification on first and last sections
- d) Joint number

### Note on guide rails with cover strip

For composite rails, a cover strip to cover the total length  $L$  is supplied separately along with the rails.

### New: Adjusting shaft

The sections of composite rails can be aligned with the aid of an adjusting shaft. For more detailed information see "Accessories" and the Instructions for Roller Rail Systems.

# Rexroth Roller Rail Systems

## Standard Steel Runner Blocks

### Runner block 1851-

#### Standard width

Special versions:

- with aluminum end caps
- hard chrome-plated

The part numbers for these versions are given on separate pages at the end of this section.

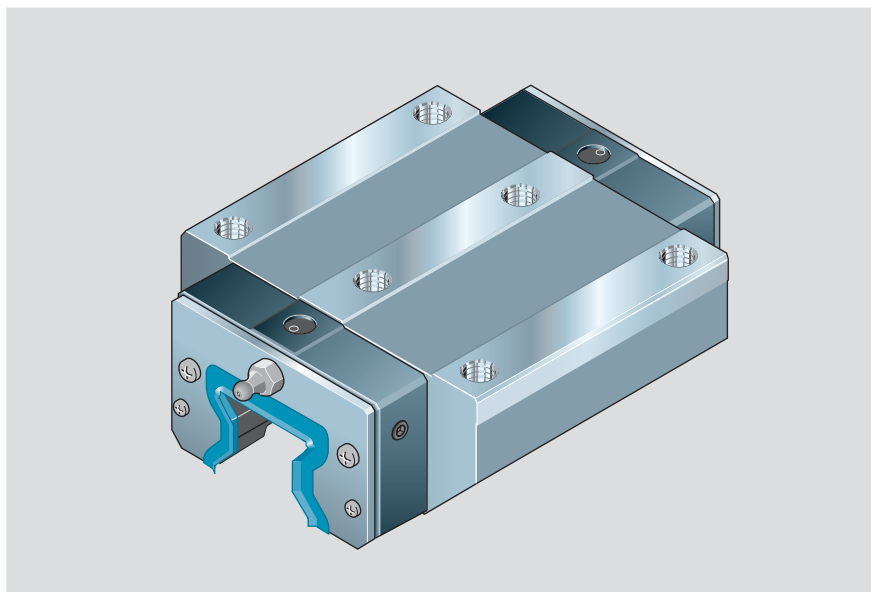

#### Part numbers

Recommended preload-accuracy class combinations:

Preload 0.08 C: H and P

Preload 0.13 C: P and SP

Runner block with preload 0.03 C on request.

Part number: 1851-. 1.-10

Runner blocks with preload 0.08 C are preferred.





Size	Accuracy class	Part numbers	
		Preload 0.08 C	Preload 0.13 C
25	UP	1851-229-10	1851-239-10
	SP	1851-221-10	1851-231-10
	P	1851-222-10	1851-232-10
	H	1851-223-10	–
35	UP	1851-329-10	1851-339-10
	SP	1851-321-10	1851-331-10
	P	1851-322-10	1851-332-10
	H	1851-323-10	–
45	UP	1851-429-10	1851-439-10
	SP	1851-421-10	1851-431-10
	P	1851-422-10	1851-432-10
	H	1851-423-10	–
55	UP	1851-529-10	1851-539-10
	SP	1851-521-10	1851-531-10
	P	1851-522-10	1851-532-10
	H	1851-523-10	–
65	UP	1851-629-10	1851-639-10
	SP	1851-621-10	1851-631-10
	P	1851-622-10	1851-632-10
	H	1851-623-10	–

#### Note on dynamic load capacities and moments

The dynamic load capacities and moments are based on 100,000 m travel.

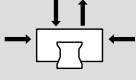
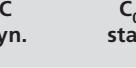
However, a travel of just 50,000 m is often taken as a basis. If this is the case, for comparison purposes:

Multiply values **C**, **M<sub>t</sub>** and **M<sub>L</sub>** from the Rexroth table by 1.23.

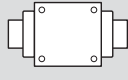
Size	Load capacities (N)		Moments (Nm)			
	 C dyn.	 C <sub>0</sub> stat.	 M <sub>t</sub> dyn.	 M <sub>t0</sub> stat.	 M <sub>L</sub> dyn.	 M <sub>L0</sub> stat.
25	26900	53200	348	690	260	520
35	56300	113500	1114	2245	700	1400
45	92300	184800	2277	4559	1430	2860
55	128900	248600	3779	7288	2400	4620
65	207000	382000	7300	13500	4590	8470



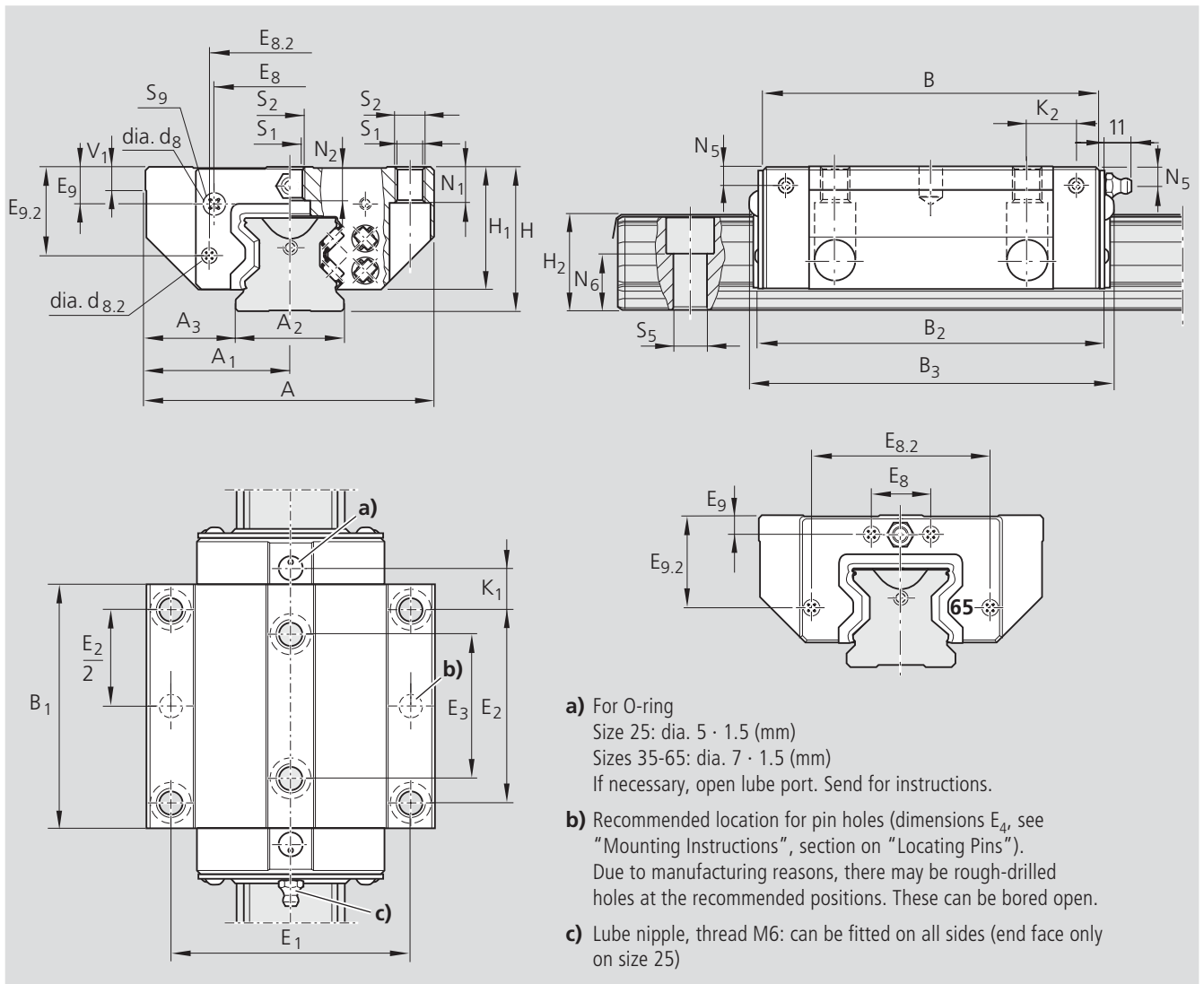

Size	Dimensions (mm)																	
	A	A <sub>1</sub>	A <sub>2</sub>	A <sub>3</sub>	B	B <sub>1</sub>	B <sub>2</sub>	B <sub>3</sub>	H	H <sub>1</sub>	H <sub>2</sub> <sup>1)</sup>	H <sub>2</sub> <sup>2)</sup>	V <sub>1</sub>	d <sub>8</sub>	d <sub>8.2</sub>	E <sub>1</sub>	E <sub>2</sub>	E <sub>3</sub>
25	70	35	23	23.5	91.0	63.5	93.0	97	36	30	23.55	23.40	7.5	5.7	-	57	45	40
35	100	50	34	33.0	114.0	79.6	116.0	121	48	41	31.10	30.80	8.0	5.7	5.2	82	62	52
45	120	60	45	37.5	140.0	101.5	144.0	150	60	51	39.10	38.80	10.0	7.6	5.7	100	80	60
55	140	70	53	43.5	166.5	123.1	170.5	177	70	58	47.85	47.55	12.0	9.5	5.7	116	95	70
65	170	85	63	53.5	206.0	146.0	216.5	218	90	76	58.15	57.85	15.0	7.6	7.6	142	110	82

<sup>1)</sup> Dimension H<sub>2</sub> with cover strip

<sup>2)</sup> Dimension H<sub>2</sub> without cover strip

Size	Dimensions (mm)														Weight (kg)
	E <sub>8</sub>	E <sub>8.2</sub>	E <sub>9</sub>	E <sub>9.2</sub>	N <sub>1</sub>	N <sub>2</sub>	N <sub>5</sub>	N <sub>6</sub> <sup>±0.5</sup>	S <sub>1</sub>	S <sub>2</sub>	S <sub>5</sub>	S <sub>9</sub> <sup>3)</sup>	K <sub>1</sub>	K <sub>2</sub>	
25	33.4	-	8.40	21.40	9	7.3	5.5	14.3	6.8	M8	7	M3-5deep	14.10	-	0.8
35	50.3	56.6	13.10	29.10	12	11.0	7.0	19.4	8.6	M10	9	M3-5deep	15.55	17.40	1.7
45	62.9	69.55	16.75	36.50	15	13.5	8.0	22.4	10.5	M12	14	M4-7deep	17.45	20.35	3.3
55	74.2	81.60	18.95	40.75	18	13.7	9.0	28.7	12.5	M14	16	M5-8deep	21.75	24.90	5.5
65	35.0	106.00	9.30	55.00	23	21.5	9.3	36.5	14.5	M16	18	M4-7deep	29.80	33.00	12.0

<sup>3)</sup> Thread for attachments

# Rexroth Roller Rail Systems

## Standard Steel Runner Blocks

### Runner block 1853- Standard width, long

Special versions:

- with aluminum end caps
- hard chrome-plated

The part numbers for these versions are given on separate pages at the end of this section.

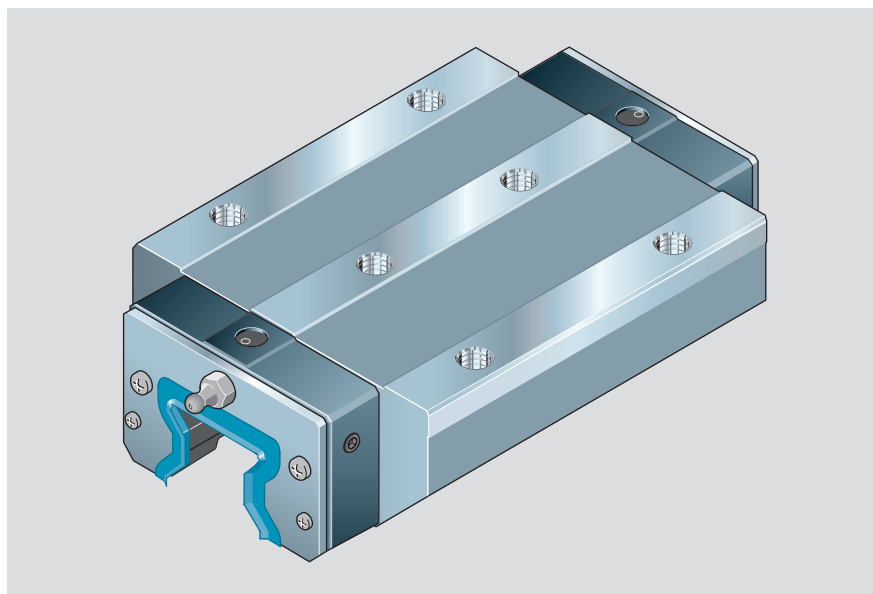

### Part numbers

Recommended preload-accuracy class combinations:

Preload 0.08 C: H and P

Preload 0.13 C: P and SP

Runner block with preload 0.03 C on request.

Part number: 1853-.1.-10

Runner blocks with preload class 0.08 C are preferred.

Size	Accuracy class	Part numbers	
		Preload 0.08 C	Preload 0.13 C
25	UP	1853-229-10	1853-239-10
	SP	1853-221-10	1853-231-10
	P	1853-222-10	1853-232-10
	H	1853-223-10	–
35	UP	1853-329-10	1853-339-10
	SP	1853-321-10	1853-331-10
	P	1853-322-10	1853-332-10
	H	1853-323-10	–
45	UP	1853-429-10	1853-439-10
	SP	1853-421-10	1853-431-10
	P	1853-422-10	1853-432-10
	H	1853-423-10	–
55	UP	1853-529-10	1853-539-10
	SP	1853-521-10	1853-531-10
	P	1853-522-10	1853-532-10
	H	1853-523-10	–
65	UP	1853-629-10	1853-639-10
	SP	1853-621-10	1853-631-10
	P	1853-622-10	1853-632-10
	H	1853-623-10	–

### Note on dynamic load capacities and moments

The dynamic load capacities and moments are based on 100,000 m travel.

However, a travel of just 50,000 m is often taken as a basis. If this is the case, for comparison purposes:

Multiply values  $C$ ,  $M_t$  and  $M_L$  from the Rexroth table by 1.23.

Size	Load capacities (N)		Moments (Nm)			
	$C_{dyn.}$	$C_{0 stat.}$	$M_t dyn.$	$M_{t0 stat.}$	$M_L dyn.$	$M_{L0 stat.}$
25	33300	70000	432	908	420	900
35	69700	149300	1375	2953	1135	2430
45	119200	256600	2941	6331	2520	5430
55	165000	345300	4837	10122	4030	8440
65	265500	525600	9410	18630	7960	15760

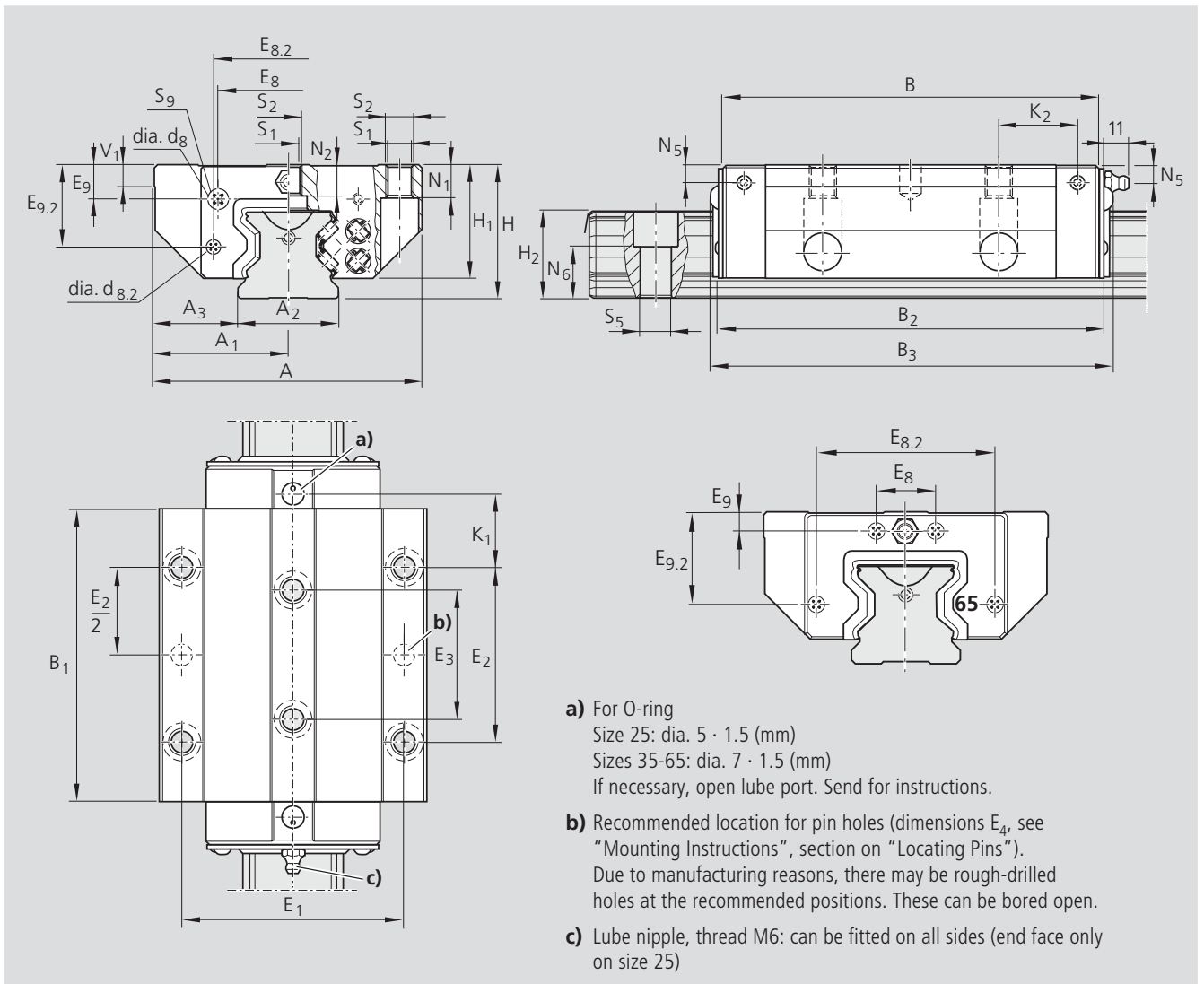

Size	Dimensions (mm)																	
	A	A <sub>1</sub>	A <sub>2</sub>	A <sub>3</sub>	B	B <sub>1</sub>	B <sub>2</sub>	B <sub>3</sub>	H	H <sub>1</sub>	H <sub>2</sub> <sup>1)</sup>	H <sub>2</sub> <sup>2)</sup>	V <sub>1</sub>	d <sub>8</sub>	d <sub>8.2</sub>	E <sub>1</sub>	E <sub>2</sub>	E <sub>3</sub>
25	70	35	23	23.5	109.0	81.5	111.0	115	36	30	23.55	23.40	7.5	5.7	—	57	45	40
35	100	50	34	33.0	138.0	103.6	140.0	145	48	41	31.10	30.80	8.0	5.7	5.2	82	62	52
45	120	60	45	37.5	172.5	134.0	176.5	183	60	51	39.10	38.80	10.0	7.6	5.7	100	80	60
55	140	70	53	43.5	205.5	162.1	209.5	216	70	58	47.85	47.55	12.0	9.5	5.7	116	95	70
65	170	85	63	53.5	254.0	194.0	258.5	264	90	76	58.15	57.85	15.0	7.6	7.6	142	110	82

<sup>1)</sup> Dimension H<sub>2</sub> with cover strip

<sup>2)</sup> Dimension H<sub>2</sub> without cover strip

Size	Dimensions (mm)														Weight (kg)
	E <sub>8</sub>	E <sub>8.2</sub>	E <sub>9</sub>	E <sub>9.2</sub>	N <sub>1</sub>	N <sub>2</sub>	N <sub>5</sub>	N <sub>6</sub> <sup>±0.5</sup>	S <sub>1</sub>	S <sub>2</sub>	S <sub>5</sub>	S <sub>9</sub> <sup>3)</sup>	K <sub>1</sub>	K <sub>2</sub>	
25	33.4	—	8.40	21.40	9	7.3	5.5	14.3	6.8	M8	7	M3-5deep	23.10	—	1.1
35	50.3	56.60	13.10	29.10	12	11.0	7.0	19.4	8.6	M10	9	M3-5deep	27.55	29.4	2.5
45	62.9	69.55	16.75	36.50	15	13.5	8.0	22.4	10.5	M12	14	M4-7deep	33.70	36.6	4.7
55	74.2	81.60	18.95	40.75	18	13.7	9.0	28.7	12.5	M14	16	M5-8deep	41.25	44.4	7.7
65	35.0	106.00	9.30	55.00	23	21.5	9.3	36.5	14.5	M16	18	M4-7deep	53.80	57.0	14.5

<sup>3)</sup> Thread for attachments

# Rexroth Roller Rail Systems

## Standard Steel Runner Blocks

### Runner block 1821-

#### Slimline, high

Special versions:

- with aluminum end caps
- hard chrome-plated

The part numbers for these versions are given on separate pages at the end of this section.

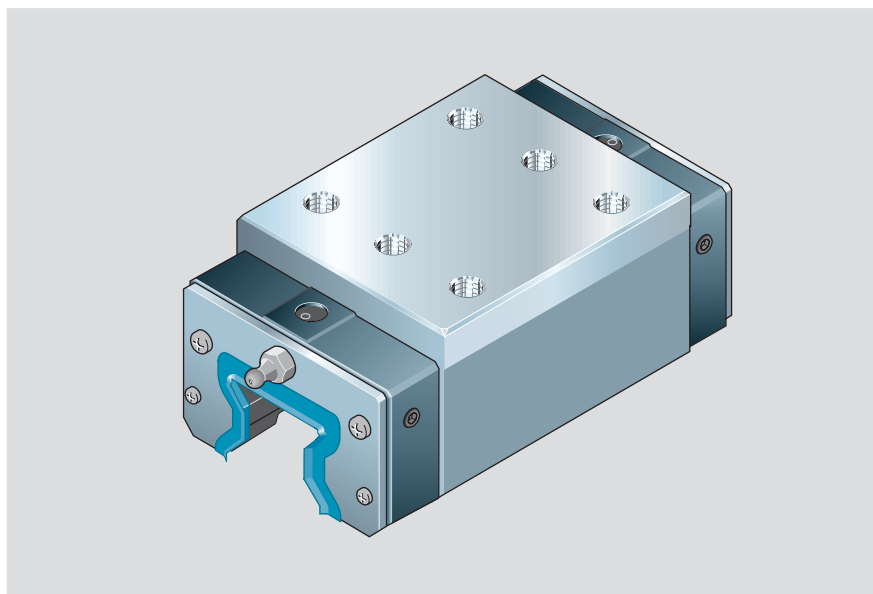

#### Part numbers

Recommended preload-accuracy class combinations:

Preload 0.08 C: H and P

Preload 0.13 C: P and SP

Runner block with preload 0.03 C on request.

Part number: 1821-.1.-10

Runner blocks with preload 0.08 C are preferred.

Size	Accuracy class	Part numbers	
		Preload 0.08 C	Preload 0.13 C
25	UP	1821-229-10	1821-239-10
	SP	1821-221-10	1821-231-10
	P	1821-222-10	1821-232-10
	H	1821-223-10	–
35	UP	1821-329-10	1821-339-10
	SP	1821-321-10	1821-331-10
	P	1821-322-10	1821-332-10
	H	1821-323-10	–
45	UP	1821-429-10	1821-439-10
	SP	1821-421-10	1821-431-10
	P	1821-422-10	1821-432-10
	H	1821-423-10	–
55	UP	1821-529-10	1821-539-10
	SP	1821-521-10	1821-531-10
	P	1821-522-10	1821-532-10
	H	1821-523-10	–

#### Note on dynamic load capacities and moments

The dynamic load capacities and moments are based on 100,000 m travel.

However, a travel of just 50,000 m is often taken as a basis. If this is the case, for comparison purposes:

Multiply values  $C$ ,  $M_t$  and  $M_L$  from the Rexroth table by 1.23.

Size	Load capacities (N)		Moments (Nm)			
	C	C <sub>0</sub>	M <sub>t</sub> dyn.	M <sub>t0</sub> stat.	M <sub>L</sub> dyn.	M <sub>L0</sub> stat.
25	26900	53200	348	690	260	520
35	56300	113500	1114	2245	700	1400
45	92300	184800	2277	4559	1430	2860
55	128900	248600	3779	7288	2400	4620

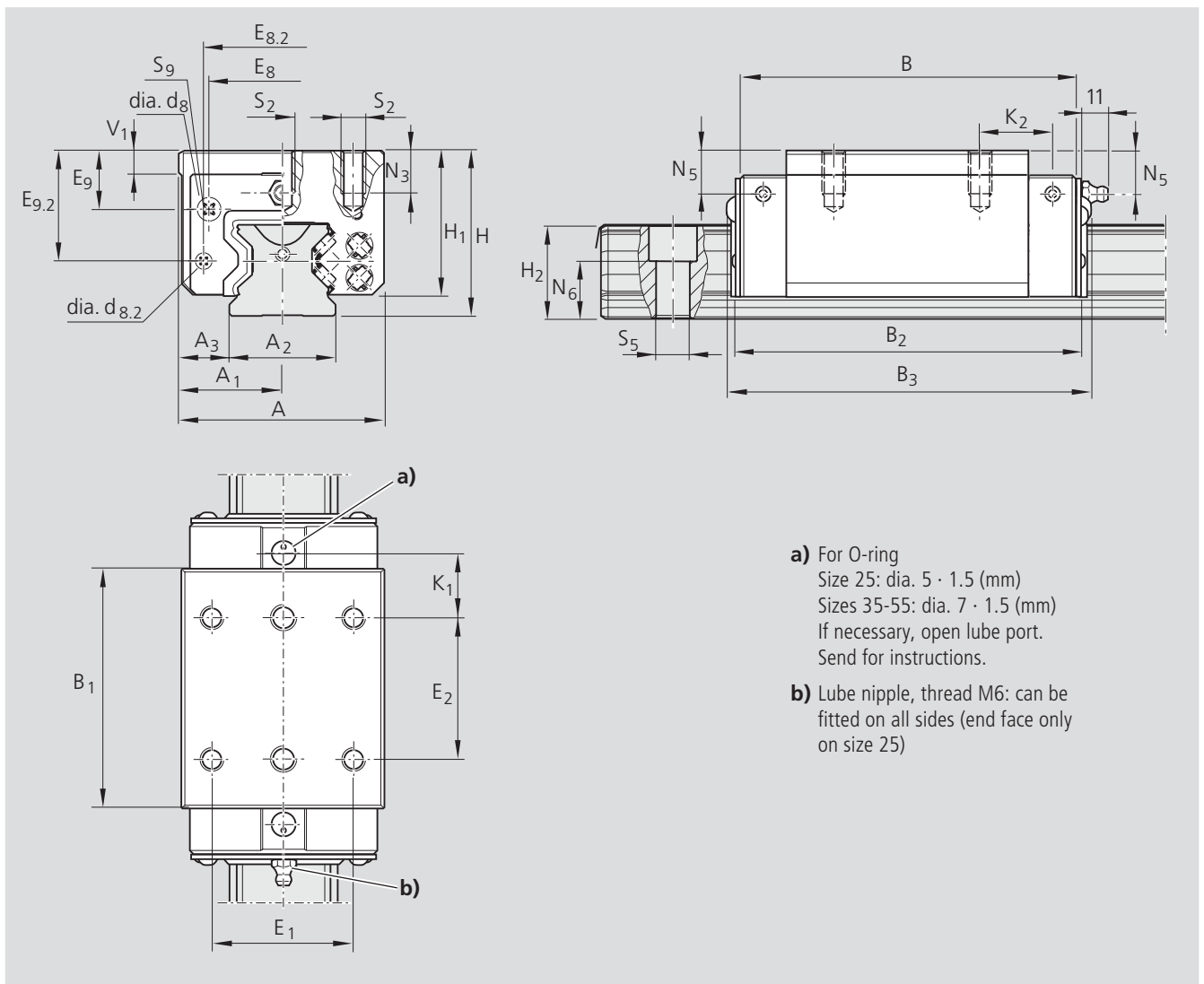

- a)** For O-ring  
 Size 25: dia. 5 · 1.5 (mm)  
 Sizes 35-55: dia. 7 · 1.5 (mm)  
 If necessary, open lube port.  
 Send for instructions.
- b)** Lube nipple, thread M6: can be fitted on all sides (end face only on size 25)

Size	Dimensions (mm)																
	A	A <sub>1</sub>	A <sub>2</sub>	A <sub>3</sub>	B	B <sub>1</sub>	B <sub>2</sub>	B <sub>3</sub>	H	H <sub>1</sub>	H <sub>2</sub> <sup>1)</sup>	H <sub>2</sub> <sup>2)</sup>	V <sub>1</sub>	d <sub>8</sub>	d <sub>8.2</sub>	E <sub>1</sub>	E <sub>2</sub>
25	48	24	23	12.5	91.0	63.5	93.0	97	40	34	23.55	23.40	7.5	5.7	–	35	35
35	70	35	34	18.0	114.0	79.6	116.0	121	55	48	31.10	30.80	8.0	5.7	5.2	50	50
45	86	43	45	20.5	140.0	101.5	144.0	150	70	61	39.10	38.80	10.0	7.6	5.7	60	60
55	100	50	53	23.5	166.5	123.1	170.5	177	80	68	47.85	47.55	12.0	9.5	5.7	75	75

<sup>1)</sup> Dimension H<sub>2</sub> with cover strip

<sup>2)</sup> Dimension H<sub>2</sub> without cover strip

Size	Dimensions (mm)													Weight (kg)
	E <sub>8</sub>	E <sub>8.2</sub>	E <sub>9</sub>	E <sub>9.2</sub>	N <sub>3</sub>	N <sub>5</sub>	N <sub>6</sub> <sup>±0.5</sup>	S <sub>2</sub>	S <sub>5</sub>	S <sub>9</sub> <sup>3)</sup>	K <sub>1</sub>	K <sub>2</sub>		
25	33.4	–	12.40	25.40	9	9.5	14.3	M6	7	M3-5deep	19.10	–	0.6	
35	50.3	56.60	20.10	36.10	13	14.0	19.4	M8	9	M3-5deep	21.55	23.40	1.5	
45	62.9	69.55	26.75	46.50	18	18.0	22.4	M10	14	M4-7deep	27.45	30.35	3.1	
55	74.2	81.60	28.95	50.75	19	19.0	28.7	M12	16	M5-8deep	31.75	34.95	4.6	

<sup>3)</sup> Thread for attachments

# Rexroth Roller Rail Systems

## Standard Steel Runner Blocks

### Runner block 1824-

**Slimline, high, long**  
(size 65: slimline, long)

Special versions:

- with aluminum end caps
- hard chrome-plated

The part numbers for these versions are given on separate pages at the end of this section.

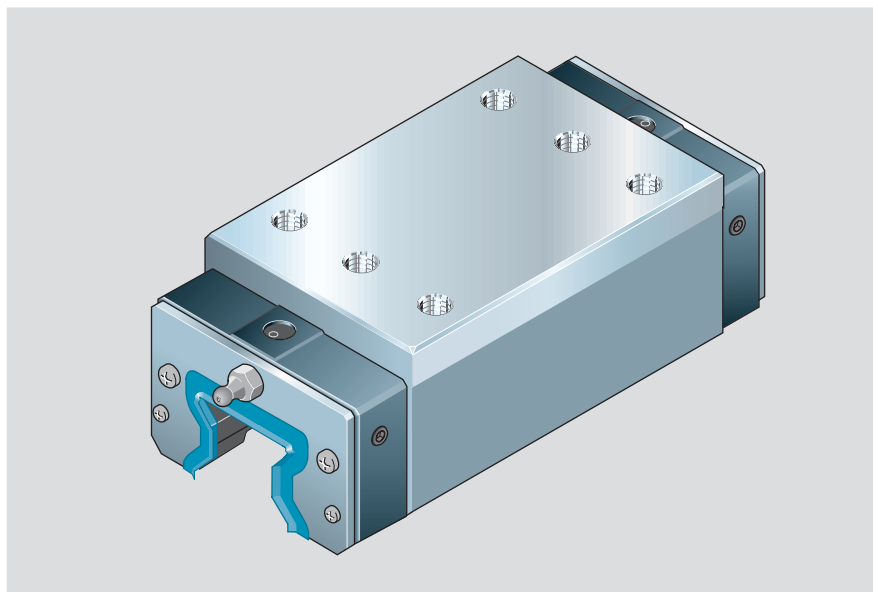

### Part numbers

Recommended preload-accuracy class combinations:

Preload 0.08 C: H and P

Preload 0.13 C: P and SP

Runner block with preload 0.03 C on request.

Part number: 1824-.1.-10

Runner blocks with preload 0.08 C are preferred.

Size	Accuracy class	Part numbers	
		Preload 0.08 C	Preload 0.13 C
25	UP	1824-229-10	1824-239-10
	SP	1824-221-10	1824-231-10
	P	1824-222-10	1824-232-10
	H	1824-223-10	–
35	UP	1824-329-10	1824-339-10
	SP	1824-321-10	1824-331-10
	P	1824-322-10	1824-332-10
	H	1824-323-10	–
45	UP	1824-429-10	1824-439-10
	SP	1824-421-10	1824-431-10
	P	1824-422-10	1824-432-10
	H	1824-423-10	–
55	UP	1824-529-10	1824-539-10
	SP	1824-521-10	1824-531-10
	P	1824-522-10	1824-532-10
	H	1824-523-10	–
65	UP	1824-629-10	1824-639-10
	SP	1824-621-10	1824-631-10
	P	1824-622-10	1824-632-10
	H	1824-623-10	–

### Note on dynamic load capacities and moments

The dynamic load capacities and moments are based on 100,000 m travel.

However, a travel of just 50,000 m is often taken as a basis. If this is the case, for comparison purposes:

Multiply values  $C$ ,  $M_t$  and  $M_L$  from the Rexroth table by 1.23.

Size	Load capacities (N)		Moments (Nm)			
	$C$	$C_0$	$M_t$ dyn.	$M_{t0}$ stat.	$M_L$ dyn.	$M_{L0}$ stat.
25	33300	70000	432	908	420	900
35	69700	149300	1375	2953	1135	2430
45	119200	256600	2941	6331	2520	5430
55	165000	345300	4837	10122	4030	8440
65	265500	525600	9410	18630	7960	15760

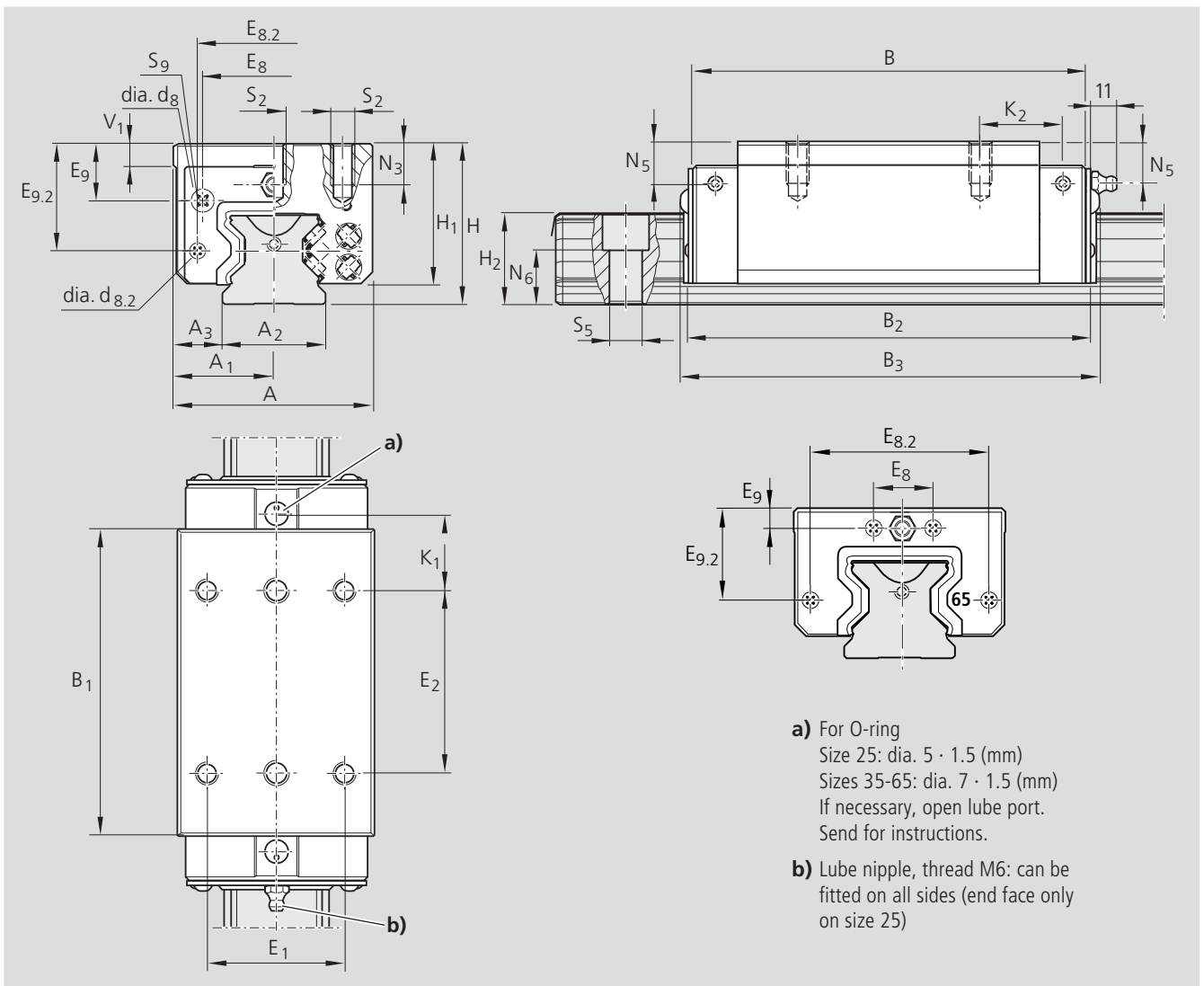

Dimensions (mm)																	
Size	A	A <sub>1</sub>	A <sub>2</sub>	A <sub>3</sub>	B	B <sub>1</sub>	B <sub>2</sub>	B <sub>3</sub>	H	H <sub>1</sub>	H <sub>2</sub> <sup>1)</sup>	H <sub>2</sub> <sup>2)</sup>	V <sub>1</sub>	d <sub>8</sub>	d <sub>8.2</sub>	E <sub>1</sub>	E <sub>2</sub>
25	48	24	23	12.5	109.0	81.5	111.0	115	40	34	23.55	23.40	7.5	5.7	–	35	50
35	70	35	34	18.0	138.0	103.6	140.0	145	55	48	31.10	30.80	8.0	5.7	5.2	50	72
45	86	43	45	20.5	172.5	134.0	176.5	183	70	61	39.10	38.80	10.0	7.6	5.7	60	80
55	100	50	53	23.5	205.5	162.1	209.5	216	80	68	47.85	47.55	12.0	9.5	5.7	75	95
65	126	63	63	31.5	254.0	194.0	258.5	264	90	76	58.15	57.85	15.0	7.6	7.6	76	120

<sup>1)</sup> Dimension H<sub>2</sub> with cover strip

<sup>2)</sup> Dimension H<sub>2</sub> without cover strip

Dimensions (mm)														Weight (kg)
Size	E <sub>8</sub>	E <sub>8.2</sub>	E <sub>9</sub>	E <sub>9.2</sub>	N <sub>3</sub>	N <sub>5</sub>	N <sub>6</sub> <sup>±0.5</sup>	S <sub>2</sub>	S <sub>5</sub>	S <sub>9</sub> <sup>3)</sup>	K <sub>1</sub>	K <sub>2</sub>		
25	33.4	–	12.40	25.40	9	9.5	14.3	M6	7	M3-5deep	20.60	–	0.9	
35	50.3	56.60	20.10	36.10	13	14.0	19.4	M8	9	M3-5deep	22.55	24.4	2.0	
45	62.9	69.55	26.75	46.50	18	18.0	22.4	M10	14	M4-7deep	33.70	36.6	4.2	
55	74.2	81.60	28.95	50.75	19	19.0	28.7	M12	16	M5-8deep	41.25	44.4	6.2	
65	35.0	106.00	9.30	55.00	21	9.3	36.5	M16	18	M4-7deep	48.80	52.0	12.0	

<sup>3)</sup> Thread for attachments

# Rexroth Roller Rail Systems

## Standard Steel Runner Blocks for Wall Mounting

### Runner block 1851-...-18

Standard width, for wall mounting

With two oil lube ports on each end face for targeted lubricant supply to the upper and lower raceways

Note: This runner block type has no top or side lube ports.

Size	Lube port spacing Dimensions in mm	
	N <sub>5</sub>	X
35*	7	32
45	8	40
55*	9	50

Size	Lube port size
35*	M6
45	M6
55*	M6

\* In preparation

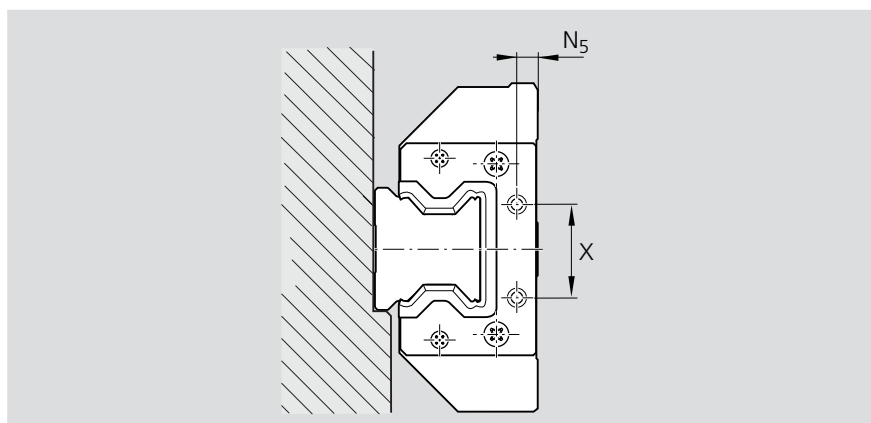

Size	Accuracy class <sup>1)</sup>	Part numbers	
		Preload 0.08 C	Preload 0.13 C
35*	SP	–	1851-331-18
	P	1851-322-18	–
45	SP	–	1851-431-18
	P	1851-422-18	–
55*	SP	–	1851-531-18
	P	1851-522-18	–

<sup>1)</sup> UP on request

### Runner block 1853-...-18

Standard width, for wall mounting

With two oil lube ports on each end face for targeted lubricant supply to the upper and lower raceways

Note: This runner block type has no top or side lube ports.

Size	Lube port spacing Dimensions in mm	
	N <sub>5</sub>	X
35*	7	32
45	8	40
55*	9	50

Size	Lube port size
35*	M6
45	M6
55*	M6

\* In preparation

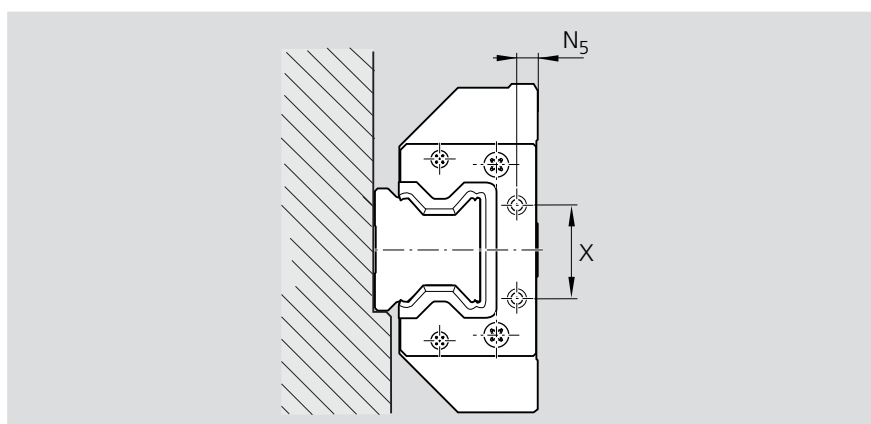

Size	Accuracy class <sup>1)</sup>	Part numbers	
		Preload 0.08 C	Preload 0.13 C
35*	SP	–	1853-331-18
	P	1853-322-18	–
45	SP	–	1853-431-18
	P	1853-422-18	–
55*	SP	–	1853-531-18
	P	1853-522-18	–

<sup>1)</sup> UP on request



## Runner block 1821-...-18

Slimline, high, for wall mounting

With two oil lube ports on each end face for targeted lubricant supply to the upper and lower raceways

Note: This runner block type has no top or side lube ports.

Size	Lube port spacing Dimensions in mm	
	N <sub>5</sub>	X
35*	7	32
45	8	40
55*	9	50

Size	Lube port size
35*	M6
45	M6
55*	M6

\* In preparation

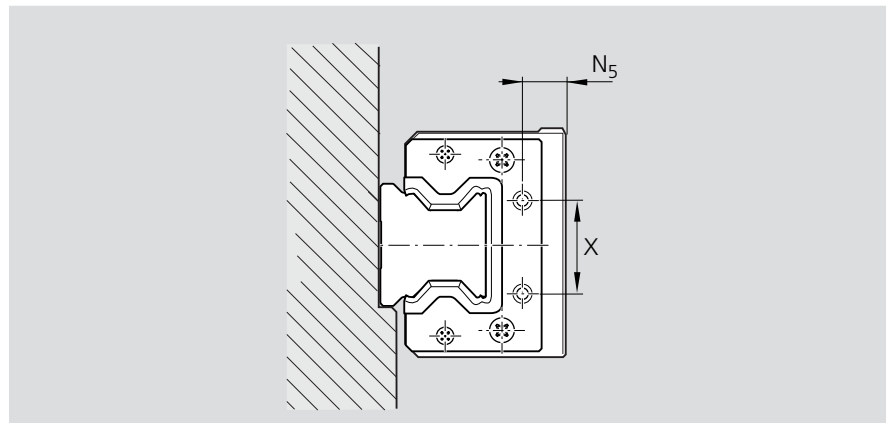

Size	Accuracy class <sup>1)</sup>	Part numbers	
		Preload 0.08 C	Preload 0.13 C
35*	SP	–	1821-331-18
	P	1821-322-18	–
45	SP	–	1821-431-18
	P	1821-422-18	–
55*	SP	–	1821-531-18
	P	1821-522-18	–

<sup>1)</sup> UP on request

## Runner block 1824-...-18

Slimline, high, long, for wall mounting

With two oil lube ports on each end face for targeted lubricant supply to the upper and lower raceways

Note: This runner block type has no top or side lube ports.

Size	Lube port spacing Dimensions in mm	
	N <sub>5</sub>	X
35*	7	32
45	8	40
55*	9	50

Size	Lube port size
35*	M6
45	M6
55*	M6

\* In preparation

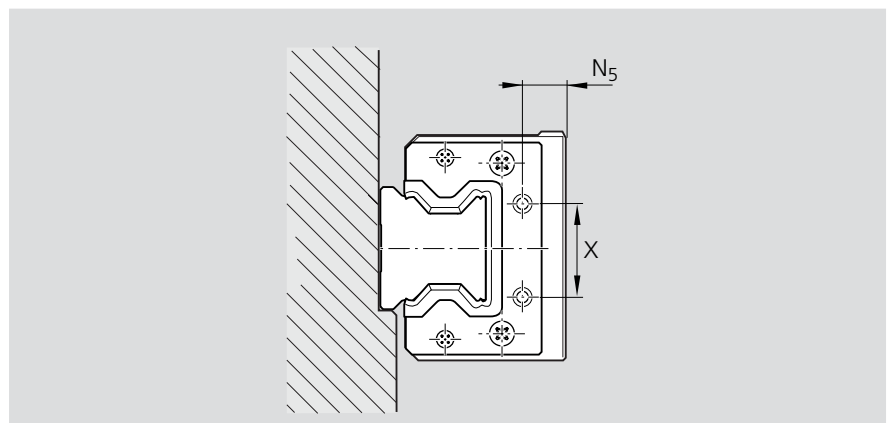

Size	Accuracy class <sup>1)</sup>	Part numbers	
		Preload 0.08 C	Preload 0.13 C
35*	SP	–	1824-331-18
	P	1824-322-18	–
45	SP	–	1824-431-18
	P	1824-422-18	–
55*	SP	–	1824-531-18
	P	1824-522-18	–

<sup>1)</sup> UP on request

# Rexroth Roller Rail Systems

## Standard Steel Runner Blocks with Aluminum End Caps

### Runner block 1851-...-13

#### Standard width

#### With aluminum end caps

For dimensions, load capacities and moments, see runner block 1851-

#### Notes

For lubrication from above, remove screw plug.

For O-ring:

Sizes 35 and 55: dia. 7 · 1.5 (mm)

Sizes 45 and 65: dia. 10 · 1.5 (mm)

Aluminum end caps with integrated seal and end seal can also be ordered separately. See "Accessories/Spare Parts".

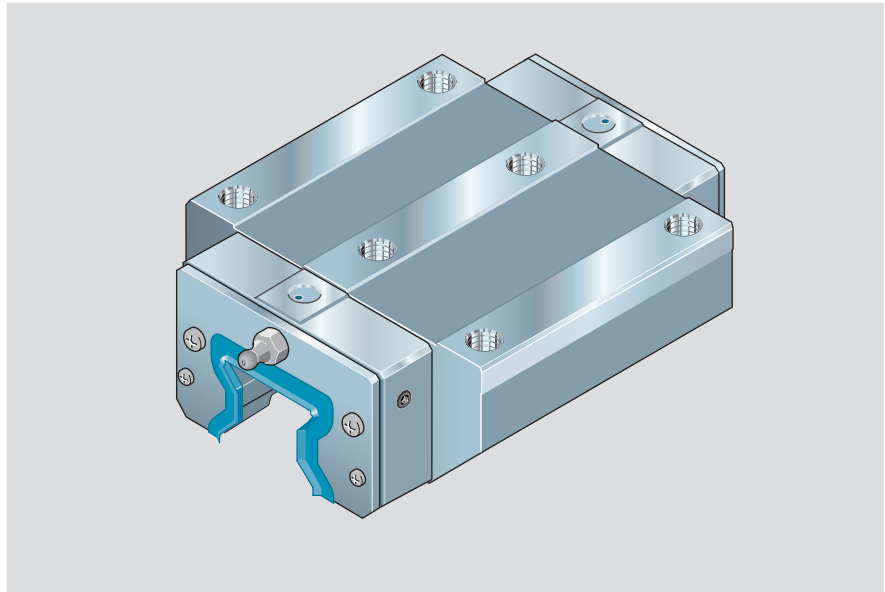

#### Part numbers

Size 25 in preparation

Size	Accuracy class	Part numbers	
		Preload 0.08 C	Preload 0.13 C
35	SP	–	1851-331-13
	P	1851-322-13	–
45	SP	–	1851-431-13
	P	1851-422-13	–
55	SP	–	1851-531-13
	P	1851-522-13	–
65	SP	–	1851-631-13
	P	1851-622-13	–

# Standard Steel Runner Blocks with Aluminum End Caps

## Runner block 1853-...-13

Standard width, long

With aluminum end caps

For dimensions, load capacities and moments, see runner block 1853-

### Notes

For lubrication from above, remove screw plug.

For O-ring:

Sizes 35 and 55: dia. 7 · 1.5 (mm)

Sizes 45 and 65: dia. 10 · 1.5 (mm)

Aluminum end caps with integrated seal and end seal can also be ordered separately. See "Accessories/Spare Parts".

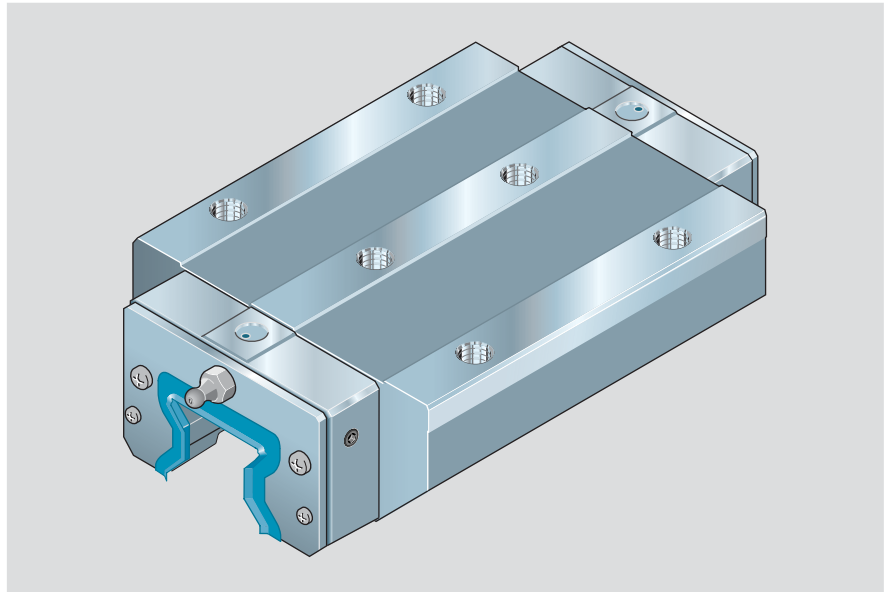

### Part numbers

Size 25 in preparation

Size	Accuracy class	Part numbers	
		Preload 0.08 C	Preload 0.13 C
35	SP	–	1853-331-13
	P	1853-322-13	–
45	SP	–	1853-431-13
	P	1853-422-13	–
55	SP	–	1853-531-13
	P	1853-522-13	–
65	SP	–	1853-631-13
	P	1853-622-13	–

# Rexroth Roller Rail Systems

## Standard Steel Runner Blocks with Aluminum End Caps

### Runner block 1821-...-13

**Slimline, high**

**With aluminum end caps**

For dimensions, load capacities and moments, see runner block 1821-

#### Notes

For lubrication from above, remove screw plug.

For O-ring:

Sizes 35 and 55: dia. 7 · 1.5 (mm)

Size 45: dia. 10 · 1.5 (mm)

Use lube adaptor (not included in supply scope, see "Accessories").

Aluminum end caps with integrated seal and end seal can also be ordered separately. See "Accessories / Spare Parts".

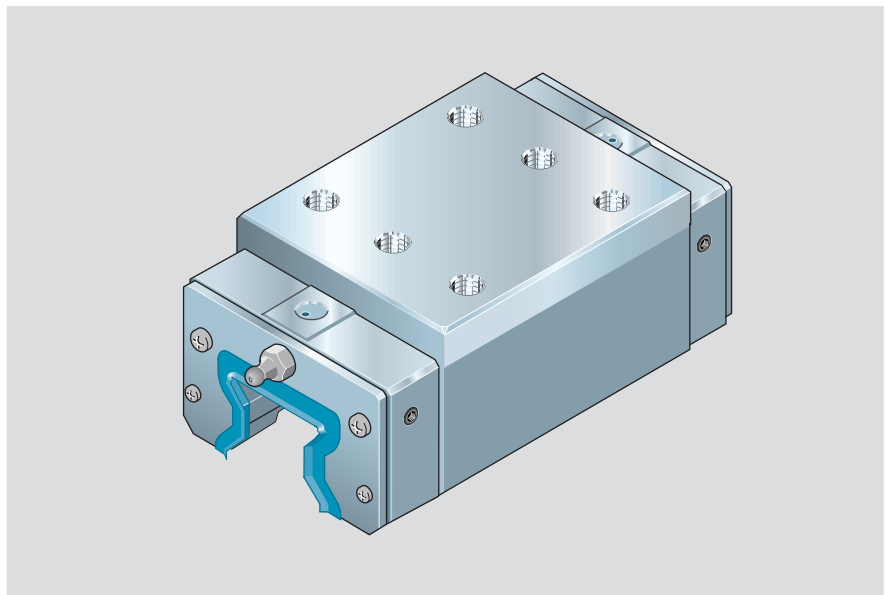

#### Part numbers

Size 25 in preparation

Size	Accuracy class	Part numbers	
		Preload 0.08 C	Preload 0.13 C
35	SP	–	1821-331-13
	P	1821-322-13	–
45	SP	–	1821-431-13
	P	1821-422-13	–
55	SP	–	1821-531-13
	P	1821-522-13	–

# Standard Steel Runner Blocks with Aluminum End Caps

## Runner block 1824-...-13

**Slimline, high, long**  
(size 65: slimline, long)

### With aluminum end caps

For dimensions, load capacities and moments, see runner block 1824-

### Notes

For lubrication from above, remove screw plug.

For O-ring:

Sizes 35 and 55: dia. 7 · 1.5 (mm)

Sizes 45 and 65: dia. 10 · 1.5 (mm)

Use lube adaptor (not included in supply scope, see "Accessories").

Aluminum end caps with integrated seal and end seal can also be ordered separately. See "Accessories/Spare Parts".

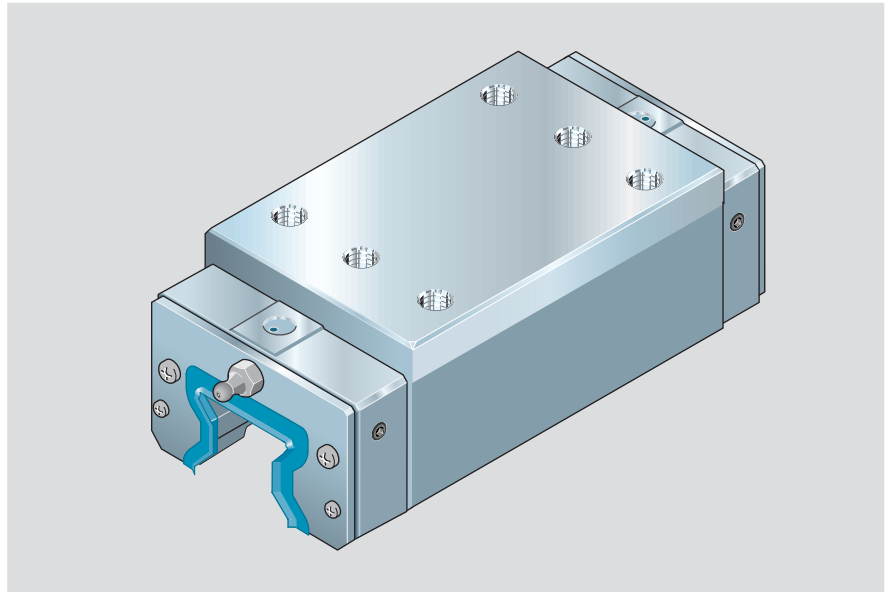

### Part numbers

Size 25 in preparation

Size	Accuracy class	Part numbers	
		Preload 0.08 C	Preload 0.13 C
35	SP	–	1824-331-13
	P	1824-322-13	–
45	SP	–	1824-431-13
	P	1824-422-13	–
55	SP	–	1824-531-13
	P	1824-522-13	–
65	SP	–	1824-631-13
	P	1824-622-13	–

# Rexroth Roller Rail Systems

## Standard Steel Runner Blocks, Hard Chrome-Plated

### Runner block 1851-...-60

**Standard width**  
**Hard chrome-plated**

Note: For tolerances other than those specified here for dimensions H and A<sub>3</sub>, see the table of accuracy classes and their tolerances in the "Technical Data" section.

Combining a hard chrome-plated runner block with a hard chrome-plated guide rail results in a preload of approx. 0.1 C.

For other dimensions as well as load capacities and moments, see runner block 1851-

Hard chrome-plated runner blocks in accuracy class SP and P are available on request.

A version with aluminum end caps in sizes 35 to 65 is also available on request. Part numbers 18..-...-63.

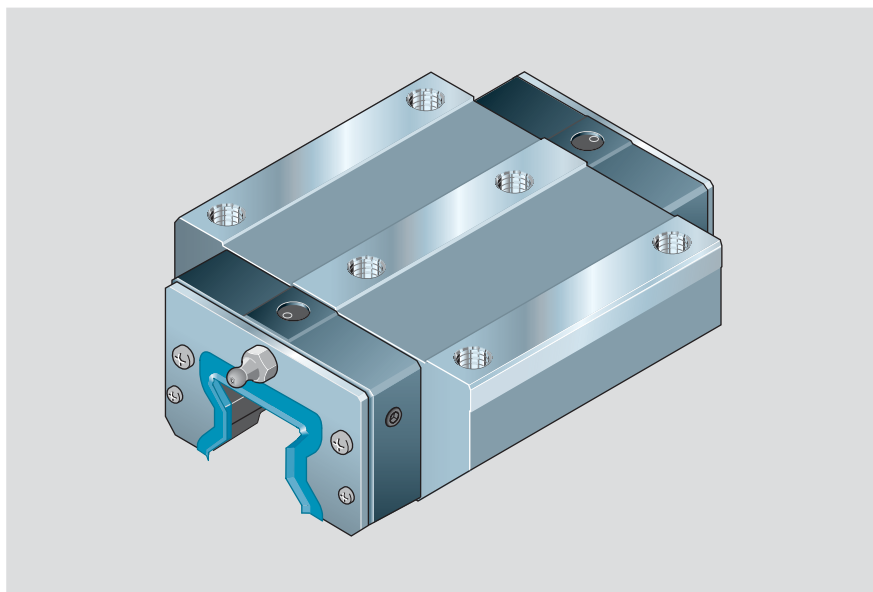

Size	Accuracy class	Part numbers	
		Preload 0.08 C	
25	H	1851-223-60	
35	H	1851-323-60	
45	H	1851-423-60	
55	H	1851-523-60	
65	H	1851-623-60	

### Runner block 1853-...-60

**Standard width, long**  
**Hard chrome-plated**

Note: For tolerances other than those specified here for dimensions H and A<sub>3</sub>, see the table of accuracy classes and their tolerances in the "Technical Data" section.

Combining a hard chrome-plated runner block with a hard chrome-plated guide rail results in a preload of approx. 0.1 C.

For other dimensions as well as load capacities and moments, see runner block 1853-

Hard chrome-plated runner blocks in accuracy class SP and P are available on request.

A version with aluminum end caps in sizes 35 to 65 is also available on request. Part numbers 18..-...-63.

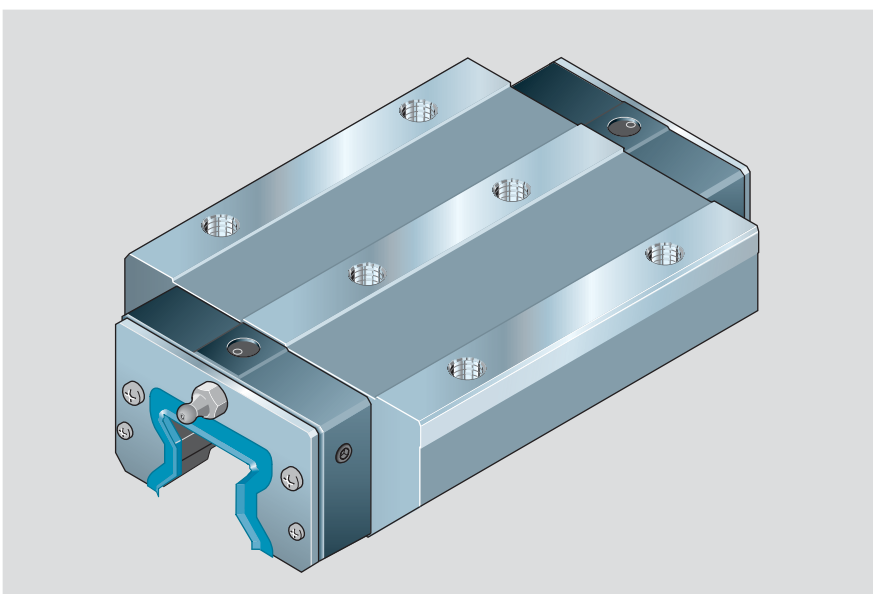

Size	Accuracy class	Part numbers	
		Preload 0.08 C	
25	H	1853-223-60	
35	H	1853-323-60	
45	H	1853-423-60	
55	H	1853-523-60	
65	H	1853-623-60	

# Standard Steel Runner Blocks, Hard Chrome-Plated

## Runner block 1821-...-60

**Slimline, high  
Hard chrome-plated**

Note: For tolerances other than those specified here for dimensions H and A<sub>3</sub>, see the table of accuracy classes and their tolerances in the "Technical Data" section.

Combining a hard chrome-plated runner block with a hard chrome-plated guide rail results in a preload of approx. 0.1 C.

For other dimensions as well as load capacities and moments, see runner block 1821-

Hard chrome-plated runner blocks in accuracy class SP and P are available on request.

A version with aluminum end caps in sizes 35 to 55 is also available on request. Part numbers 18...-...-63.

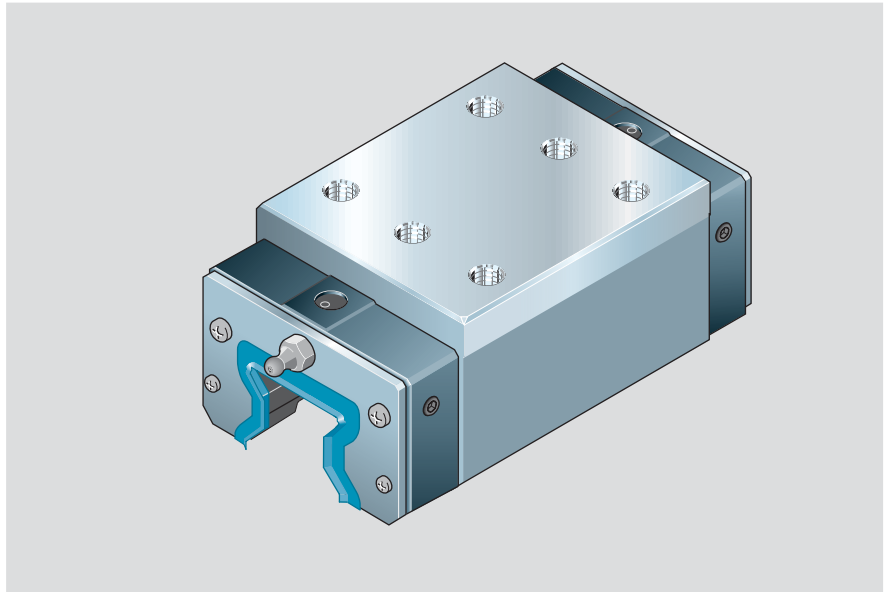

Size	Accuracy class	Part numbers	
		Preload 0.08 C	
25	H	1821-223-60	
35	H	1821-323-60	
45	H	1821-423-60	
55	H	1821-523-60	

## Runner block 1824-...-60

**Slimline, high, long  
(size 65: slimline, long)  
Hard chrome-plated**

Note: For tolerances other than those specified here for dimensions H and A<sub>3</sub>, see the table of accuracy classes and their tolerances in the "Technical Data" section.

Combining a hard chrome-plated runner block with a hard chrome-plated guide rail results in a preload of approx. 0.1 C.

For other dimensions as well as load capacities and moments, see runner block 1824-

Hard chrome-plated runner blocks in accuracy class SP and P are available on request.

A version with aluminum end caps in sizes 35 to 55 is also available on request. Part numbers 18...-...-63.

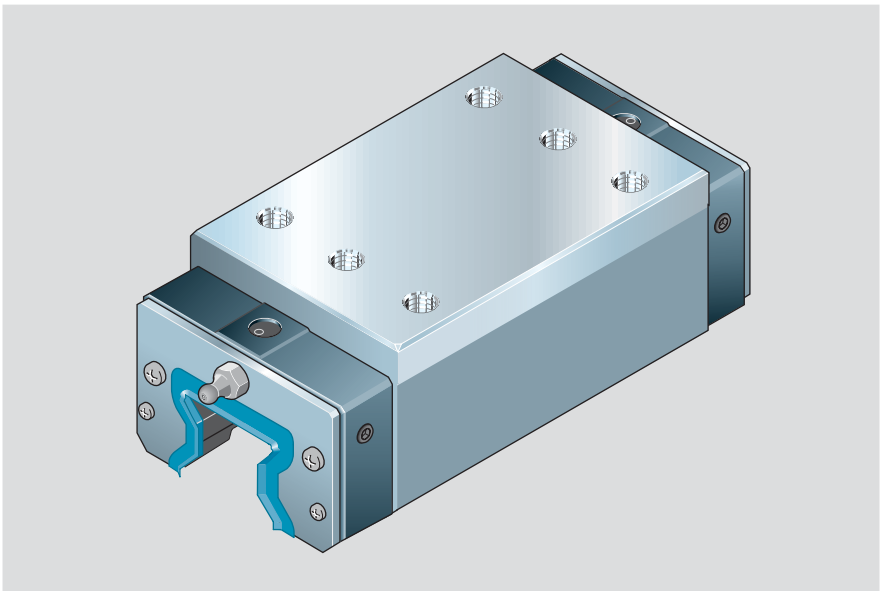

Size	Accuracy class	Part numbers	
		Preload 0.08 C	
25	H	1824-223-60	
35	H	1824-323-60	
45	H	1824-423-60	
55	H	1824-523-60	
65	H	1824-623-60	

# Rexroth Roller Rail Systems

## Product Overview – Standard Guide Rails

Proven cover strip for guide rail mounting holes:

- A *single* cover for all holes
- Stainless spring steel to EN 10088
- Easy to fit – simply clip on and secure

Guide rails with cover strip and plastic protective caps

- with tap holes at the end faces

Guide rails with cover strip, screw and washer

- with tap holes at the end faces

Guide rails with cover strip and strip clamp

- without tap holes at the end faces

Guide rails with plastic mounting hole plugs

Guide rails with steel mounting hole plugs

Guide rails for mounting from below

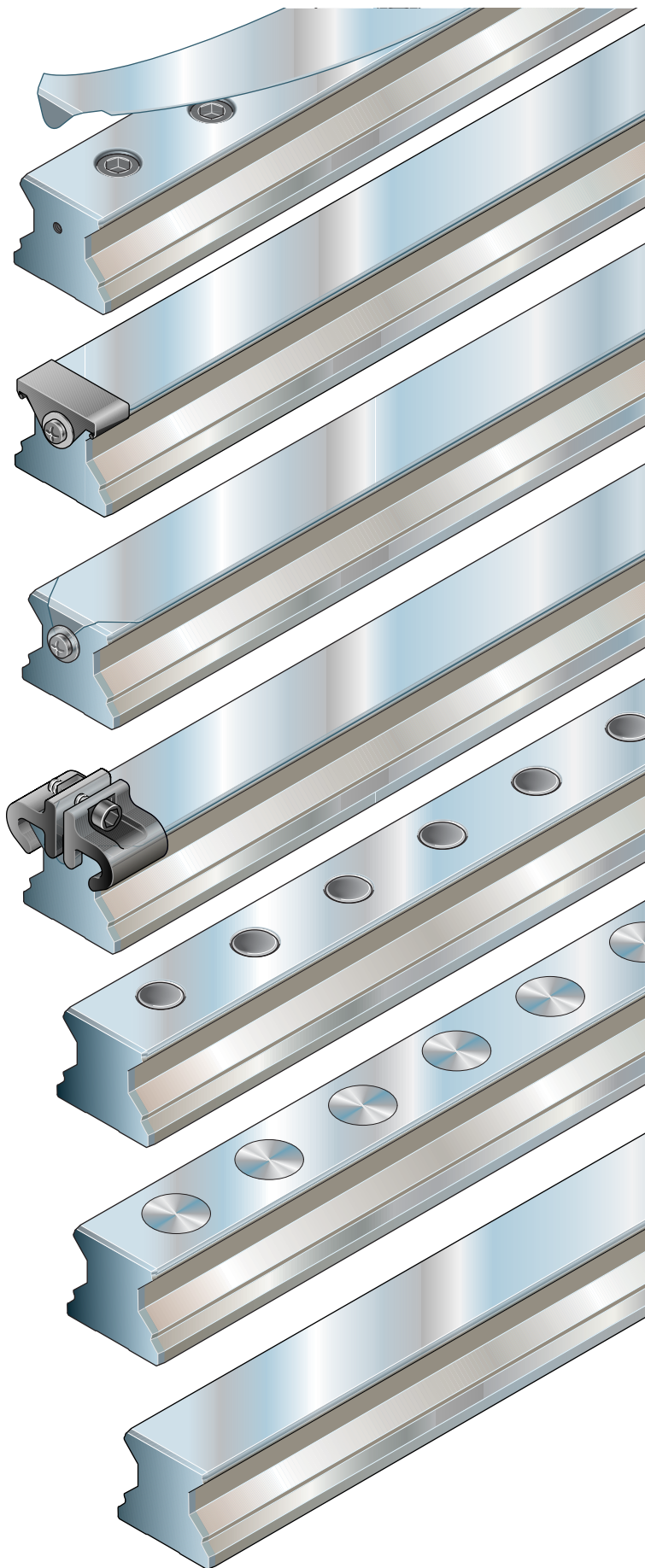



# Ordering Examples – Standard Guide Rails

## Ordering guide rails in recommended lengths

The following examples apply to all guide rail orders. Recommended rail lengths are delivered with priority.

### From the desired length to the recommended length

$$L = \left( \frac{\text{desired length } L}{\text{hole spacing } T_2} \right)^* \cdot T_2 - 4$$

\* round up to the next whole number

Example:

$$L = \left( \frac{1660 \text{ mm}}{40 \text{ mm}} \right) \cdot 40 \text{ mm} - 4 \text{ mm}$$

$$L = 42 \cdot 40 \text{ mm} - 4 \text{ mm}$$

$$L = 1676 \text{ mm}$$

### Ordering example 1, up to $L_{\max}$ :

- Guide rail size 35 with cover strip
- Accuracy class H
- Calculated rail length 1676 mm  
( $41 \cdot T_2$ , preferred dimension  
 $T_{15} = 18 \text{ mm}$ ;  
number of holes  $n_B = 42$ )

#### Ordering data:

Part number, length (mm)

$T_1 / n_{T_2} \cdot T_2 / T_1$  (mm)

**1805-363-61, 1676 mm**

**18 / 41 · 40 / 18 mm**

### Notes on ordering examples

- If the preferred dimension  $T_{15}$  cannot be used:
  - Select an end space  $T_1$  between  $T_{15}$  and  $T_{1 \min}$
  - Do not go below the minimum spacing  $T_{1 \min}$ !
- $T_1, T_{1 \min}, T_{15}$  are the same at either end of the rail.

Size	Accuracy class	Guide rail		Spacing $T_2$ (mm)	Recommended rail lengths Number of holes $n_B$ / rail length L (mm)
		one-piece Part number, Rail length L (mm)	composite Part number, Number of sections, Rail length L (mm)		
25	UP	1805-269-31, ....	1805-269-3., ....	30	according to formula $L = n_B \cdot T_2 - 4$ up to 133/3986 max.
	SP	1805-261-31, ....	1805-261-3., ....		
	P	1805-262-31, ....	1805-262-3., ....		
	H	1805-263-31, ....	1805-263-3., ....		
35	UP	1805-369-61, ....	1805-369-6., ....	40	according to formula $L = n_B \cdot T_2 - 4$ up to 100/3996 max.
	SP	1805-361-61, ....	1805-361-6., ....		
	P	1805-362-61, ....	1805-362-6., ....		
	H	1805-363-61, ....	1805-363-6., ....		
45	UP	1805-469-61, ....	1805-469-6., ....	52.5	according to formula $L = n_B \cdot T_2 - 4$ up to 76/3986 max.
	SP	1805-461-61, ....	1805-461-6., ....		
	P	1805-462-61, ....	1805-462-6., ....		
	H	1805-463-61, ....	1805-463-6., ....		
55	UP	1805-569-61, ....	1805-569-6., ....	60	according to formula $L = n_B \cdot T_2 - 4$ up to 66/3956 max.
	SP	1805-561-61, ....	1805-561-6., ....		
	P	1805-562-61, ....	1805-562-6., ....		
	H	1805-563-61, ....	1805-563-6., ....		
65	UP	1805-669-61, ....	1805-669-6., ....	75	according to formula $L = n_B \cdot T_2 - 4$ up to 53/3971 max.
	SP	1805-661-61, ....	1805-661-6., ....		
	P	1805-662-61, ....	1805-662-6., ....		
	H	1805-663-61, ....	1805-663-6., ....		

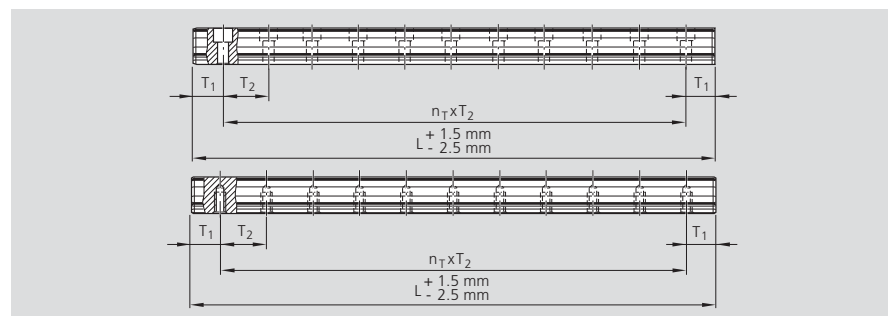

$L = n_B \cdot T_2 - 4$ <p>or</p> $L = n_{T_2} \cdot T_2 + 2 \cdot T_{15}$	$L$ = rail length (mm) $T_2$ = hole spacing*) (mm) $T_{15}$ = preferred dimension*) (mm) $n_B$ = number of holes $n_{T_2}$ = number of spaces *) see tables for values
--	---

### Ordering example 2, length $> L_{\max}$ :

- Guide rail size 35 with cover strip
- Accuracy class H
- Calculated rail length 5036 mm,  
2 sections  
( $125 \cdot T_2$ , preferred dimension  
 $T_{15} = 18 \text{ mm}$ ;  
number of holes  $n_B = 126$ )

#### Ordering data:

Part number and number of sections,  
length (mm)

$T_1 / n_{T_2} \cdot T_2 / T_1$  (mm)

**1805-363-62, 5036 mm**

**18 / 125 · 40 / 18 mm**

Rail lengths greater than  $L_{\max}$  are made up of matching rail sections mounted end to end.

# Rexroth Roller Rail Systems

## Standard Guide Rails

### Guide rail 1805-.6. -

For mounting from above,  
with cover strip of stainless spring  
steel to EN 10088 and screw-down  
protective caps

Observe the mounting instructions!

Send for the publication "Mounting  
Instructions for the Cover Strip".

Special versions:

- Hard chrome-plated guide rails. For part numbers, see "Guide rail, hard chrome-plated, 1845-.5.-".
- Securing with screw and washer to be done by the customer. Screw and washer are available as accessories.

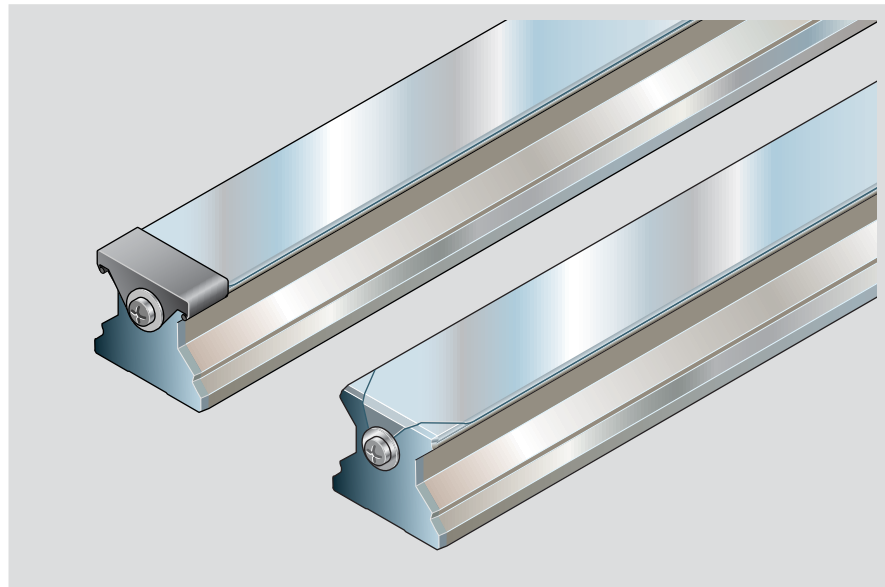

### Part numbers and rail lengths

Size	Accuracy class	Guide rail		Spacing $T_2$ (mm)	Recommended rail lengths Number of holes $n_B$ / rail length L (mm)
		one-piece Part number, Rail length L (mm)	composite Part number, Number of sections, Rail length L (mm)		
25	UP	1805-269-31, ...	1805-269-3., ...	30	according to formula $L = n_B \cdot T_2 - 4$ up to 133/3986 max.
	SP	1805-261-31, ...	1805-261-3., ...		
	P	1805-262-31, ...	1805-262-3., ...		
	H	1805-263-31, ...	1805-263-3., ...		
35	UP	1805-369-61, ...	1805-369-6., ...	40	according to formula $L = n_B \cdot T_2 - 4$ up to 100/3996 max.
	SP	1805-361-61, ...	1805-361-6., ...		
	P	1805-362-61, ...	1805-362-6., ...		
	H	1805-363-61, ...	1805-363-6., ...		
45	UP	1805-469-61, ...	1805-469-6., ...	52.5	according to formula $L = n_B \cdot T_2 - 4$ up to 76/3986 max.
	SP	1805-461-61, ...	1805-461-6., ...		
	P	1805-462-61, ...	1805-462-6., ...		
	H	1805-463-61, ...	1805-463-6., ...		
55	UP	1805-569-61, ...	1805-569-6., ...	60	according to formula $L = n_B \cdot T_2 - 4$ up to 66/3956 max.
	SP	1805-561-61, ...	1805-561-6., ...		
	P	1805-562-61, ...	1805-562-6., ...		
	H	1805-563-61, ...	1805-563-6., ...		
65	UP	1805-669-61, ...	1805-669-6., ...	75	according to formula $L = n_B \cdot T_2 - 4$ up to 53/3971 max.
	SP	1805-661-61, ...	1805-661-6., ...		
	P	1805-662-61, ...	1805-662-6., ...		
	H	1805-663-61, ...	1805-663-6., ...		

## Dimensions and weights

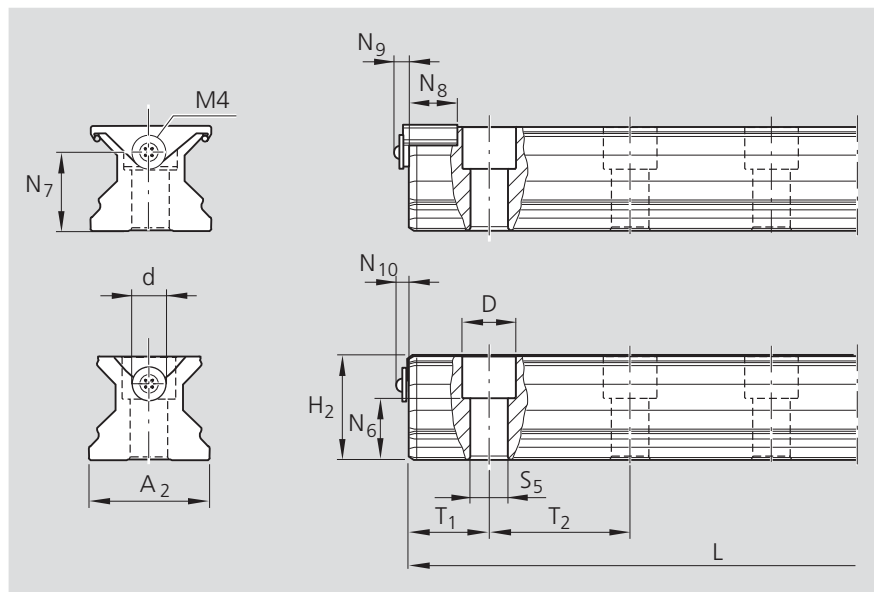

Size	Dimensions (mm)										Weight					
	A <sub>2</sub>	H <sub>2</sub> <sup>1)</sup>	N <sub>6</sub> <sup>±0.5</sup>	N <sub>7</sub>	N <sub>8</sub>	N <sub>9</sub>	N <sub>10</sub>	d	D	S <sub>5</sub>	T <sub>15</sub> <sup>+0.5</sup> <sup>2)</sup>	T <sub>1 min</sub> <sup>3)</sup>	T <sub>2</sub>	L <sub>max</sub> <sup>4)</sup>	kg/m	
<b>25</b>	23	23.55	14.3	15.0	15.2	6.5	4.10	12	11.0	7.0	13.00	13	30.0	4000	3.1	
<b>35</b>	34	31.10	19.4	22.0	18.0	7.0	4.10	15	15.0	9.0	18.00	16	40.0	4000	6.3	
<b>45</b>	45	39.10	22.4	30.0	20.0	7.0	4.10	15	20.0	14.0	24.25	18	52.5	4000	10.3	
<b>55</b>	53	47.85	28.7	30.0	20.0	7.0	4.35	20	24.0	16.0	28.00	20	60.0	4000	13.1	
<b>65</b>	63	58.15	36.5	40.0	20.0	7.0	4.35	20	26.0	18.0	35.50	21	75.0	4000	17.4	

- 1) Dimension H<sub>2</sub> with cover strip  
Size 25 with 0.15 mm cover strip  
Sizes 35 to 65 with 0.3 mm cover strip
- 2) Preferred dimension
- 3) Rails with T<sub>1</sub> smaller than T<sub>1 min</sub> have no tap hole at the end face for securing the strip!  
Secure the cover strip!  
Observe mounting instructions!  
The protective cap, washer and screw are included in the supply scope.
- 4) Sizes 35 to 65 in accuracy classes P and H are also available in lengths up to approx. 6000 mm.

# Rexroth Roller Rail Systems

## Standard Guide Rails

### Guide rail 1805-.3. -

For mounting from above,  
with cover strip of stainless spring  
steel to EN 10088 and strip clamps

Secure the cover strip!  
Observe the mounting instructions!

Send for the publication "Mounting  
Instructions for the Cover Strip".

The strip clamp is part of the supply  
scope.

Special versions:

- Hard chrome-plated guide rails with  
strip clamp are available on request.

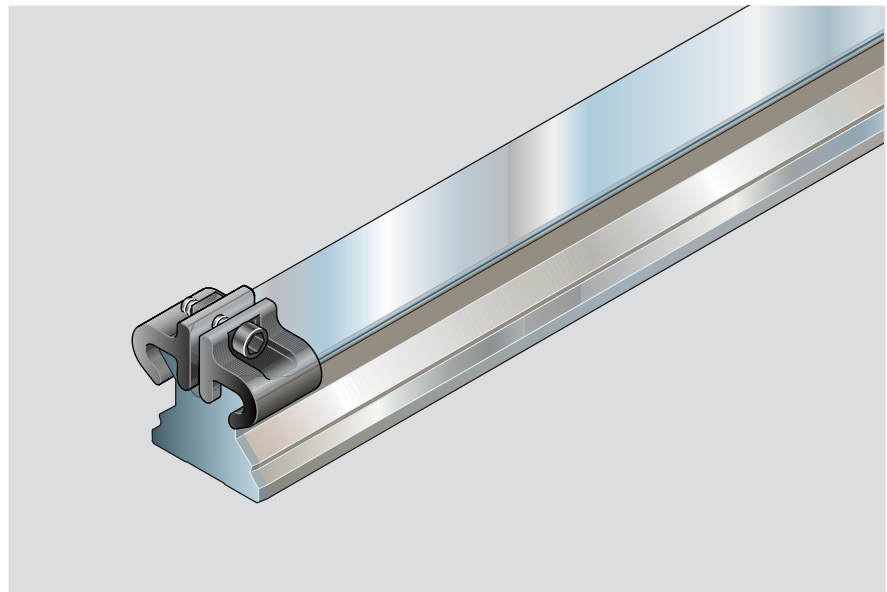

### Part numbers and rail lengths

Size	Accuracy class	Guide rail		Spacing $T_2$ (mm)	Recommended rail lengths Number of holes $n_B$ / rail length L (mm)
		one-piece Part number, Rail length L (mm)	composite Part number, Number of sections, Rail length L (mm)		
25	UP	1805-239-31, ...	1805-239-3., ...	30	according to formula $L = n_B \cdot T_2 - 4$ up to 133/3986 max.
	SP	1805-231-31, ...	1805-231-3., ...		
	P	1805-232-31, ...	1805-232-3., ...		
	H	1805-233-31, ...	1805-233-3., ...		
35	UP	1805-339-61, ...	1805-339-6., ...	40	according to formula $L = n_B \cdot T_2 - 4$ up to 100/3996 max.
	SP	1805-331-61, ...	1805-331-6., ...		
	P	1805-332-61, ...	1805-332-6., ...		
	H	1805-333-61, ...	1805-333-6., ...		
45	UP	1805-439-61, ...	1805-439-6., ...	52.5	according to formula $L = n_B \cdot T_2 - 4$ up to 76/3986 max.
	SP	1805-431-61, ...	1805-431-6., ...		
	P	1805-432-61, ...	1805-432-6., ...		
	H	1805-433-61, ...	1805-433-6., ...		
55	UP	1805-539-61, ...	1805-539-6., ...	60	according to formula $L = n_B \cdot T_2 - 4$ up to 66/3956 max.
	SP	1805-531-61, ...	1805-531-6., ...		
	P	1805-532-61, ...	1805-532-6., ...		
	H	1805-533-61, ...	1805-533-6., ...		
65	UP	1805-639-61, ...	1805-639-6., ...	75	according to formula $L = n_B \cdot T_2 - 4$ up to 53/3971 max.
	SP	1805-631-61, ...	1805-631-6., ...		
	P	1805-632-61, ...	1805-632-6., ...		
	H	1805-633-61, ...	1805-633-6., ...		

## Dimensions and weights

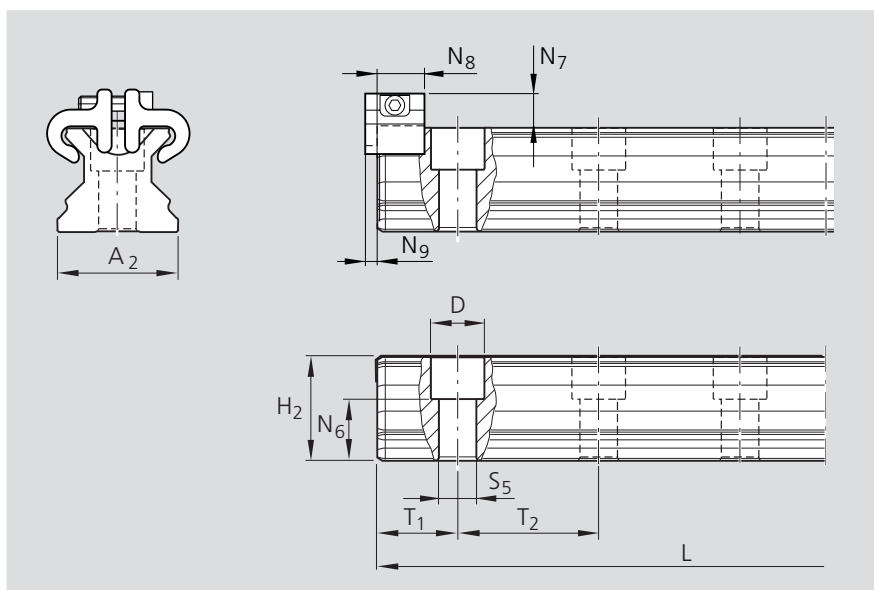

Size	Dimensions (mm)											Weight kg/m	
	A <sub>2</sub>	H <sub>2</sub> <sup>1)</sup>	N <sub>6</sub> <sup>±0.5</sup>	N <sub>7</sub> <sup>2)</sup>	N <sub>8</sub>	N <sub>9</sub>	D	S <sub>5</sub>	T <sub>15</sub> <sup>+0.5</sup> <sub>-1.0</sub> <sup>3)</sup>	T <sub>1 min</sub>	T <sub>2</sub>		L <sub>max</sub> <sup>4)</sup>
25	23	23.55	14.3	8.2	13.0	2.0	11.0	7.0	13.00	13	30.0	4000	3.1
35	34	31.10	19.4	11.7	16.0	2.2	15.0	9.0	18.00	16	40.0	4000	6.3
45	45	39.10	22.4	12.5	18.0	2.2	20.0	14.0	24.25	18	52.5	4000	10.3
55	53	47.85	28.7	14.0	17.0	3.2	24.0	16.0	28.00	20	60.0	4000	13.1
65	63	58.15	36.5	15.0	17.0	3.2	26.0	18.0	35.50	21	75.0	4000	17.4

1) Dimension H<sub>2</sub> with cover strip  
 Size 25 with 0.15 mm cover strip  
 Sizes 35 to 65 with 0.3 mm cover strip

2) Dimension N<sub>7</sub> with cover strip

3) Preferred dimension

4) Sizes 35 to 65 in accuracy classes P  
 and H are also available in lengths  
 up to approx. 6000 mm.

# Rexroth Roller Rail Systems

## Standard Guide Rails

### Guide rail 1805-.2. -

For mounting from above,  
for cover strip  
(not included)

- The cover strip and strip clamp or protective caps must be ordered separately. For part numbers and dimensions see "Accessories".

Special versions:

– hard chrome-plated

The part numbers are given on separate pages at the end of this section.

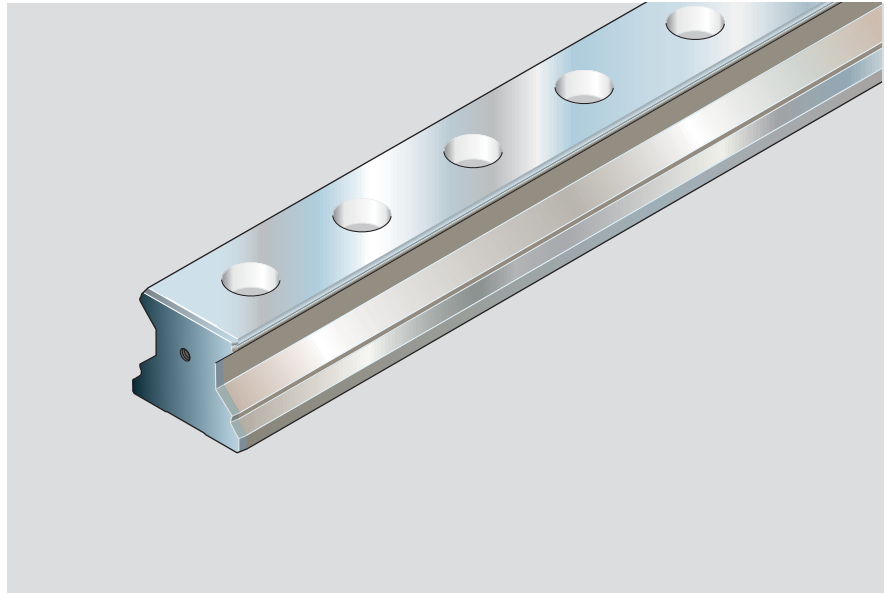

### Part numbers and rail lengths

Size	Accuracy class	Guide rail		Spacing $T_2$ (mm)	Recommended rail lengths Number of holes $n_B$ / rail length L (mm)
		one-piece Part number, Rail length L (mm)	composite Part number, Number of sections, Rail length L (mm)		
25	UP	1805-229-31, ....	1805-229-3., ....	30	according to formula $L = n_B \cdot T_2 - 4$ up to 133/3986 max.
	SP	1805-221-31, ....	1805-221-3., ....		
	P	1805-222-31, ....	1805-222-3., ....		
	H	1805-223-31, ....	1805-223-3., ....		
35	UP	1805-329-31, ....	1805-329-3., ....	40	according to formula $L = n_B \cdot T_2 - 4$ up to 100/3996 max.
	SP	1805-321-31, ....	1805-321-3., ....		
	P	1805-322-31, ....	1805-322-3., ....		
	H	1805-323-31, ....	1805-323-3., ....		
45	UP	1805-429-31, ....	1805-429-3., ....	52.5	according to formula $L = n_B \cdot T_2 - 4$ up to 76/3986 max.
	SP	1805-421-31, ....	1805-421-3., ....		
	P	1805-422-31, ....	1805-422-3., ....		
	H	1805-423-31, ....	1805-423-3., ....		
55	UP	1805-529-31, ....	1805-529-3., ....	60	according to formula $L = n_B \cdot T_2 - 4$ up to 66/3956 max.
	SP	1805-521-31, ....	1805-521-3., ....		
	P	1805-522-31, ....	1805-522-3., ....		
	H	1805-523-31, ....	1805-523-3., ....		
65	UP	1805-629-31, ....	1805-629-3., ....	75	according to formula $L = n_B \cdot T_2 - 4$ up to 53/3971 max.
	SP	1805-621-31, ....	1805-621-3., ....		
	P	1805-622-31, ....	1805-622-3., ....		
	H	1805-623-31, ....	1805-623-3., ....		

## Dimensions and weights

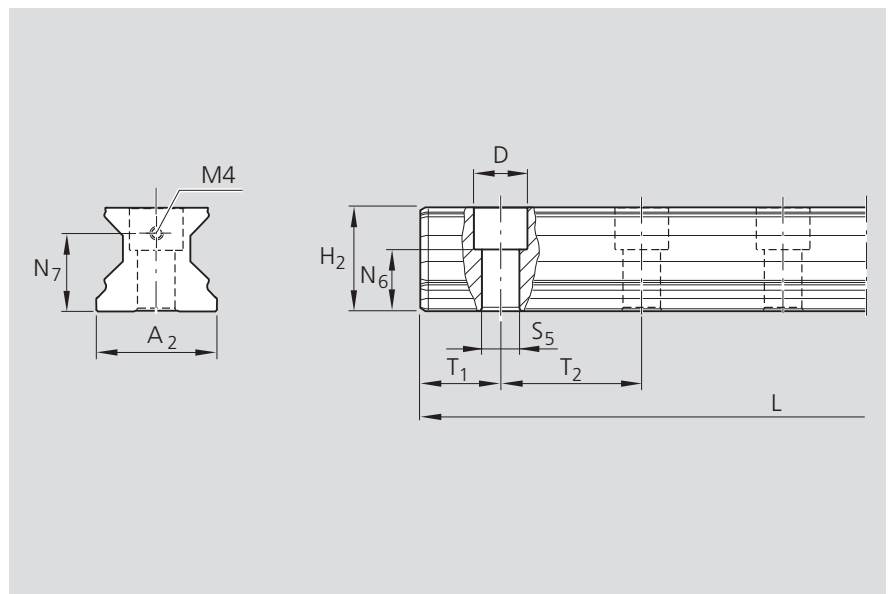

Size	Dimensions (mm)										Weight kg/m
	A <sub>2</sub>	H <sub>2</sub> <sup>1)</sup>	N <sub>6</sub> <sup>±0.5</sup>	N <sub>7</sub>	D	S <sub>5</sub>	T <sub>1S</sub> <sup>+0.5<sup>2)</sup>-1.0</sup>	T <sub>1 min</sub> <sup>3)</sup>	T <sub>2</sub>	L <sub>max</sub> <sup>4)</sup>	
<b>25</b>	23	23.40	14.3	15.0	11	7	13.00	13	30.0	4000	3.1
<b>35</b>	34	30.80	19.4	22.0	15	9	18.00	16	40.0	4000	6.3
<b>45</b>	45	38.80	22.4	30.0	20	14	24.25	18	52.5	4000	10.3
<b>55</b>	53	47.55	28.7	30.0	24	16	28.00	20	60.0	4000	13.1
<b>65</b>	63	57.85	36.5	40.0	26	18	35.50	21	75.0	4000	17.4

- 1) Dimension H<sub>2</sub> without cover strip
- 2) Preferred dimension
- 3) Rails with T<sub>1</sub> smaller than T<sub>1 min</sub> have no tap hole at the end face for securing the strip!  
Secure the cover strip!  
Observe mounting instructions!
- 4) Sizes 35 to 65 in accuracy classes P and H are also available in lengths up to approx. 6000 mm.

# Rexroth Roller Rail Systems

## Standard Guide Rails

### Guide rail 1805-.5. -

For mounting from above,  
with plastic mounting hole plugs  
(included)

Special versions:

– hard chrome-plated

The part numbers are given on separate  
pages at the end of this section.

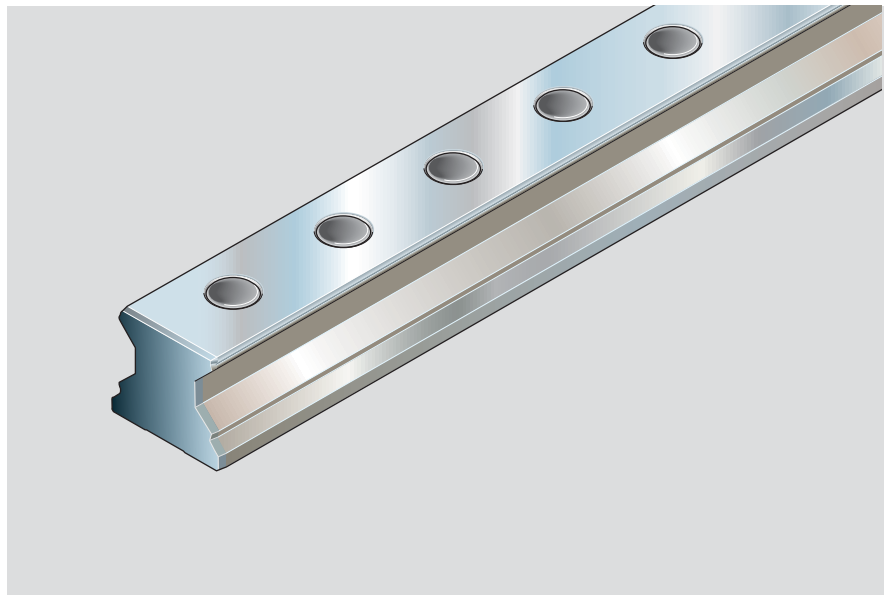

### Part numbers and rail lengths

Size	Accuracy class	Guide rail		Spacing $T_2$ (mm)	Recommended rail lengths Number of holes $n_B$ / rail length L (mm)
		one-piece Part number, Rail length L (mm)	composite Part number, Number of sections, Rail length L (mm)		
25	UP	1805-259-31, ....	1805-259-3., ....	30	according to formula $L = n_B \cdot T_2 - 4$ up to 133/3986 max.
	SP	1805-251-31, ....	1805-251-3., ....		
	P	1805-252-31, ....	1805-252-3., ....		
	H	1805-253-31, ....	1805-253-3., ....		
35	UP	1805-359-31, ....	1805-359-3., ....	40	according to formula $L = n_B \cdot T_2 - 4$ up to 100/3996 max.
	SP	1805-351-31, ....	1805-351-3., ....		
	P	1805-352-31, ....	1805-352-3., ....		
	H	1805-353-31, ....	1805-353-3., ....		
45	UP	1805-459-31, ....	1805-459-3., ....	52.5	according to formula $L = n_B \cdot T_2 - 4$ up to 76/3986 max.
	SP	1805-451-31, ....	1805-451-3., ....		
	P	1805-452-31, ....	1805-452-3., ....		
	H	1805-453-31, ....	1805-453-3., ....		
55	UP	1805-559-31, ....	1805-559-3., ....	60	according to formula $L = n_B \cdot T_2 - 4$ up to 66/3956 max.
	SP	1805-551-31, ....	1805-551-3., ....		
	P	1805-552-31, ....	1805-552-3., ....		
	H	1805-553-31, ....	1805-553-3., ....		
65	UP	1805-659-31, ....	1805-659-3., ....	75	according to formula $L = n_B \cdot T_2 - 4$ up to 53/3971 max.
	SP	1805-651-31, ....	1805-651-3., ....		
	P	1805-652-31, ....	1805-652-3., ....		
	H	1805-653-31, ....	1805-653-3., ....		



## Dimensions and weights

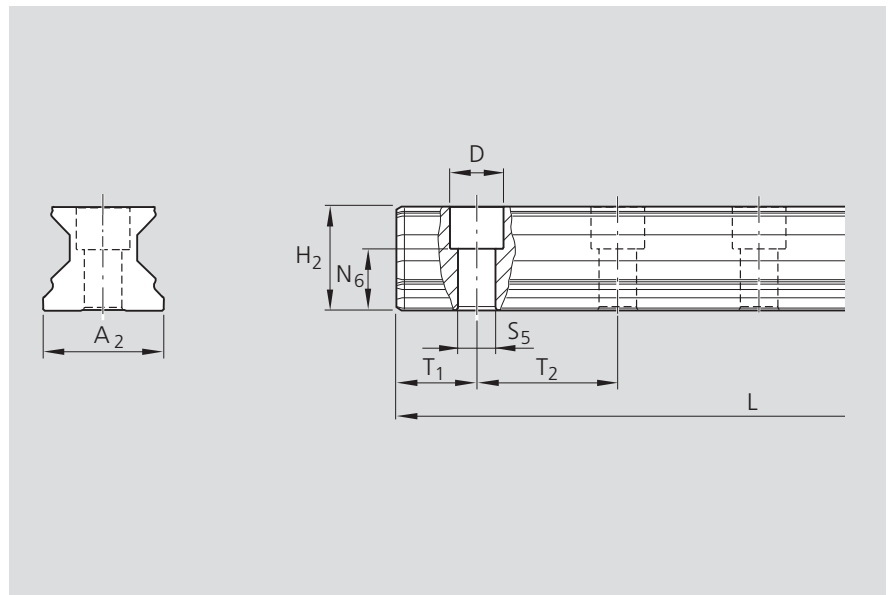

Size	Dimensions (mm)									Weight kg/m
	$A_2$	$H_2$	$N_6^{\pm 0.5}$	$D$	$S_5$	$T_{15}^{+0.5, 1)}$	$T_{1 \text{ min}}$	$T_2$	$L_{\text{max}}^{2)}$	
<b>25</b>	23	23.40	14.3	11	7	13.00	10	30.0	4000	3.1
<b>35</b>	34	30.80	19.4	15	9	18.00	12	40.0	4000	6.3
<b>45</b>	45	38.80	22.4	20	14	24.25	16	52.5	4000	10.3
<b>55</b>	53	47.55	28.7	24	16	28.00	18	60.0	4000	13.1
<b>65</b>	63	57.85	36.5	26	18	35.50	20	75.0	4000	17.4

1) Preferred dimension

2) Sizes 35 to 65 in accuracy classes P and H are also available in lengths up to approx. 6000 mm.

# Rexroth Roller Rail Systems

## Standard Guide Rails

### Guide rail 1806-.5. -

For mounting from above,  
for steel mounting hole plugs  
(not included)

Accuracy classes SP, P, H

Steel mounting hole plugs and the mounting tool must be ordered separately.  
For part numbers see "Accessories".

Observe the mounting instructions for steel mounting hole plugs.

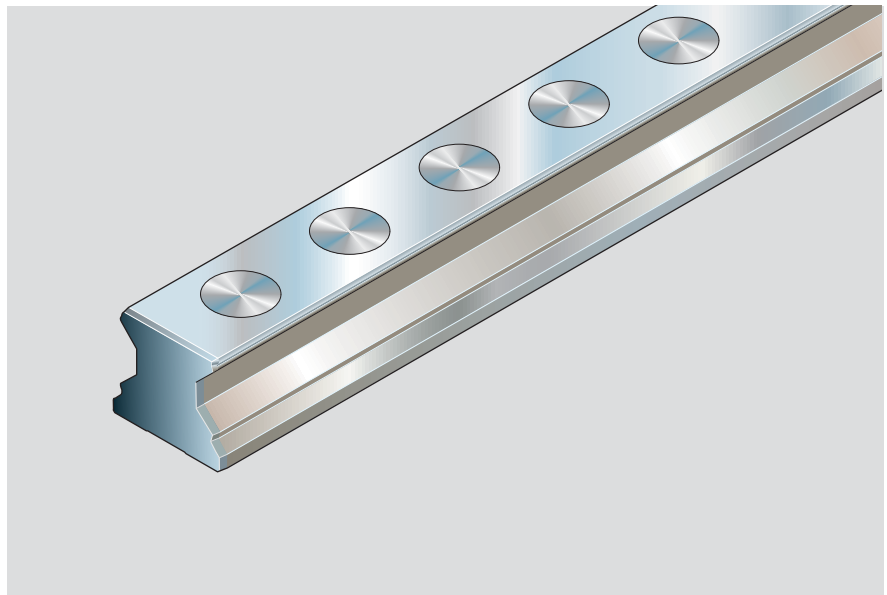

### Part numbers and rail lengths

Size	Accuracy class	Guide rail		Spacing $T_2$ (mm)	Recommended rail lengths Number of holes $n_B$ / rail length L (mm)
		one-piece Part number, Rail length L (mm)	composite Part number, Number of sections, Rail length L (mm)		
25	SP	1806-251-31, ....	1806-251-3., ....	30	according to formula $L = n_B \cdot T_2 - 4$ up to 133/3986 max.
	P	1806-252-31, ....	1806-252-3., ....		
	H	1806-253-31, ....	1806-253-3., ....		
35	SP	1806-351-31, ....	1806-351-3., ....	40	according to formula $L = n_B \cdot T_2 - 4$ up to 100/3996 max.
	P	1806-352-31, ....	1806-352-3., ....		
	H	1806-353-31, ....	1806-353-3., ....		
45	SP	1806-451-31, ....	1806-451-3., ....	52.5	according to formula $L = n_B \cdot T_2 - 4$ up to 76/3986 max.
	P	1806-452-31, ....	1806-452-3., ....		
	H	1806-453-31, ....	1806-453-3., ....		
55	SP	1806-551-31, ....	1806-551-3., ....	60	according to formula $L = n_B \cdot T_2 - 4$ up to 66/3956 max.
	P	1806-552-31, ....	1806-552-3., ....		
	H	1806-553-31, ....	1806-553-3., ....		
65	SP	1806-651-31, ....	1806-651-3., ....	75	according to formula $L = n_B \cdot T_2 - 4$ up to 53/3971 max.
	P	1806-652-31, ....	1806-652-3., ....		
	H	1806-653-31, ....	1806-653-3., ....		

## Dimensions and weights

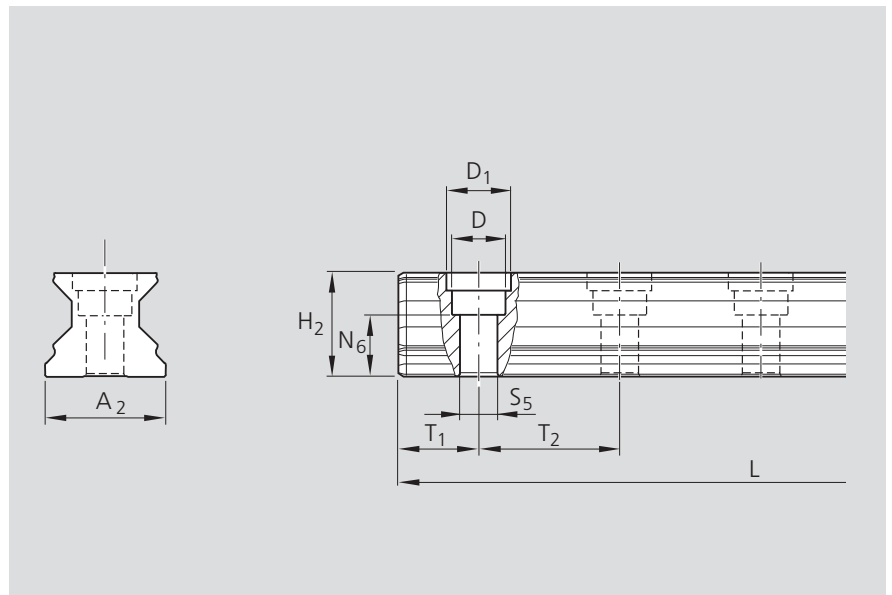

Size	Dimensions (mm)										Weight kg/m
	$A_2$	$H_2$	$N_6^{\pm 0.5}$	$D$	$D_1$	$S_5$	$T_{1S-1.0}^{+0.5}$ <sup>1)</sup>	$T_{1\min}$	$T_2$	$L_{\max}$ <sup>2)</sup>	
<b>25</b>	23	23.40	14.3	11	13	7	13.00	10	30.0	4000	3.1
<b>35</b>	34	30.80	19.4	15	18	9	18.00	12	40.0	4000	6.3
<b>45</b>	45	38.80	22.4	20	23	14	24.25	16	52.5	4000	10.3
<b>55</b>	53	47.55	28.7	24	28	16	28.00	18	60.0	4000	13.1
<b>65</b>	63	57.85	36.5	26	30	18	35.50	20	75.0	4000	17.4

<sup>1)</sup> Preferred dimension

<sup>2)</sup> Sizes 35 to 65 in accuracy classes P and H in lengths of up to approx. 6000 mm on request.

# Rexroth Roller Rail Systems

## Standard Guide Rails

### Guide rail 1807-

For mounting from below

Special versions:

– hard chrome-plated

The part numbers are given on separate pages at the end of this section.

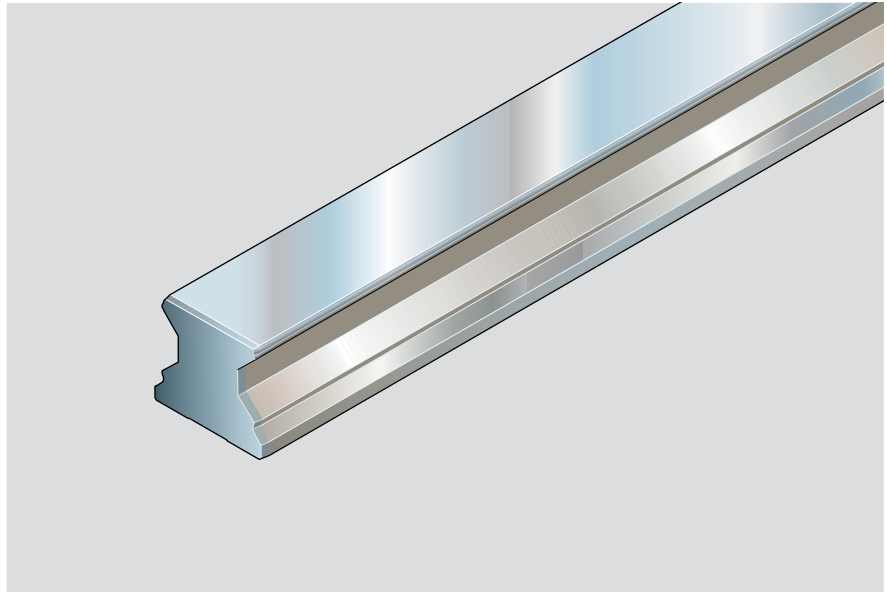

### Part numbers and rail lengths

Size	Accuracy class	Guide rail		Spacing $T_2$ (mm)	Recommended rail lengths Number of holes $n_B$ / rail length L (mm)
		one-piece Part number, Rail length L (mm)	composite Part number, Number of sections, Rail length L (mm)		
25	UP	1807-209-31, ....	1807-209-3., ....	30	according to formula $L = n_B \cdot T_2 - 4$ up to 133/3986 max.
	SP	1807-201-31, ....	1807-201-3., ....		
	P	1807-202-31, ....	1807-202-3., ....		
	H	1807-203-31, ....	1807-203-3., ....		
35	UP	1807-309-31, ....	1807-309-3., ....	40	according to formula $L = n_B \cdot T_2 - 4$ up to 100/3996 max.
	SP	1807-301-31, ....	1807-301-3., ....		
	P	1807-302-31, ....	1807-302-3., ....		
	H	1807-303-31, ....	1807-303-3., ....		
45	UP	1807-409-31, ....	1807-409-3., ....	52.5	according to formula $L = n_B \cdot T_2 - 4$ up to 76/3986 max.
	SP	1807-401-31, ....	1807-401-3., ....		
	P	1807-402-31, ....	1807-402-3., ....		
	H	1807-403-31, ....	1807-403-3., ....		
55	UP	1807-509-31, ....	1807-509-3., ....	60	according to formula $L = n_B \cdot T_2 - 4$ up to 66/3956 max.
	SP	1807-501-31, ....	1807-501-3., ....		
	P	1807-502-31, ....	1807-502-3., ....		
	H	1807-503-31, ....	1807-503-3., ....		
65	UP	1807-609-31, ....	1807-609-3., ....	75	according to formula $L = n_B \cdot T_2 - 4$ up to 53/3971 max.
	SP	1807-601-31, ....	1807-601-3., ....		
	P	1807-602-31, ....	1807-602-3., ....		
	H	1807-603-31, ....	1807-603-3., ....		

## Dimensions and weights

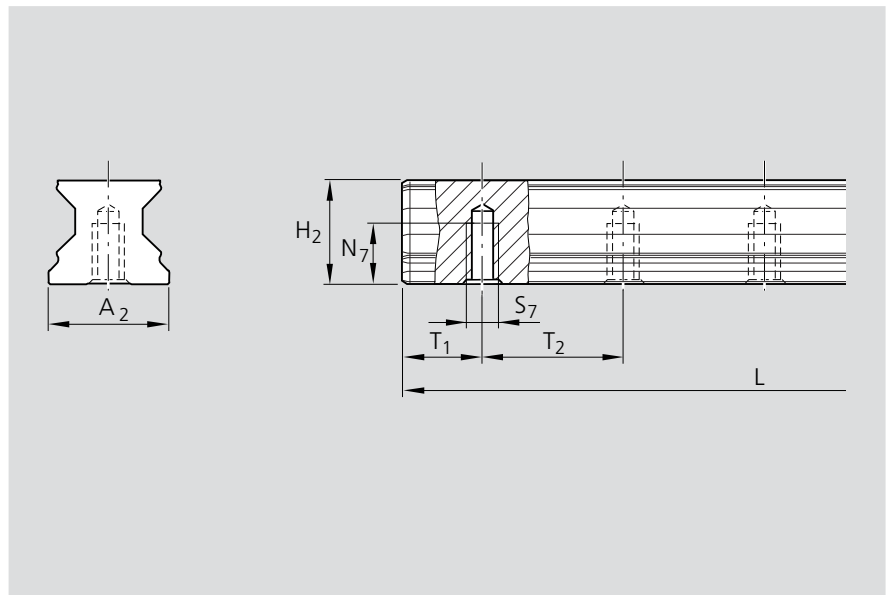

Size	Dimensions (mm)								Weight kg/m
	$A_2$	$H_2$	$N_7^{\pm 0.5}$	$S_7$	$T_{1s}^{+0.5^1}$	$T_{1 \text{ min}}$	$T_2$	$L_{\text{max}}$	
<b>25</b>	23	23.40	12	M6	13.00	10	30.0	4000	3.1
<b>35</b>	34	30.80	15	M8	18.00	12	40.0	4000	6.3
<b>45</b>	45	38.80	19	M12	24.25	16	52.5	4000	10.3
<b>55</b>	53	47.55	22	M14	28.00	18	60.0	4000	13.1
<b>65</b>	63	57.85	25	M16	35.50	20	75.0	4000	17.4

<sup>1)</sup> Preferred dimension

# Rexroth Roller Rail Systems

## Standard Guide Rails, Hard Chrome-Plated

### Guide rail 1845-.6.- Hard chrome-plated

For mounting from above,  
with cover strip in stainless spring  
steel to EN 10088 and screw-down  
protective caps

Part numbers / end face coating:

Size 25 with 0.15 mm cover strip:

– 1845-...-4. (end faces coated)

Sizes 35 to 65 with 0.3 mm cover strip:

– 1845-...-7. (end faces coated)

#### Notes

The mounting holes and the tap holes at  
the end faces are chrome-plated.

The hard chrome-plated version replaces  
the zinc-iron coated guide rails.

Securing with screw and washer to be  
done by the customer. Screw and washer  
are available as accessories.

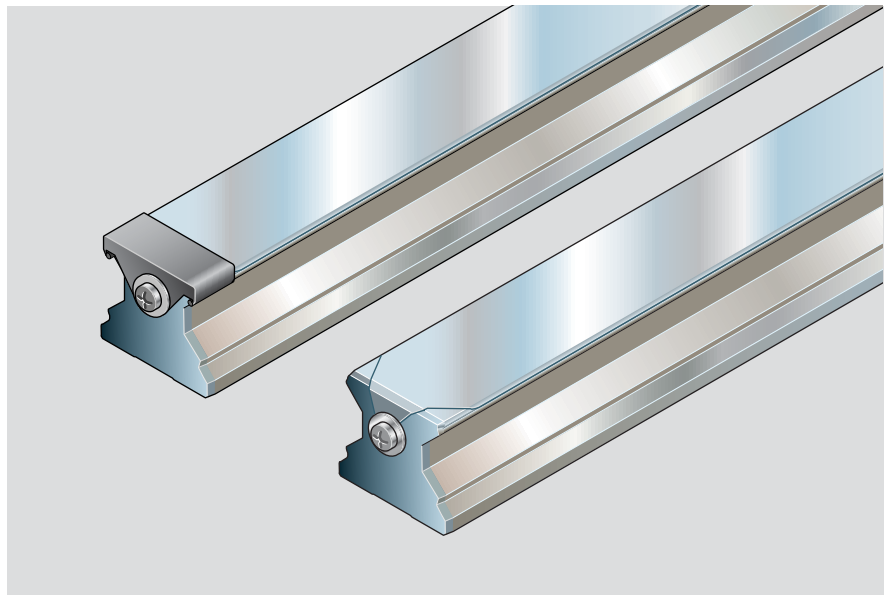

### Part numbers and rail lengths

Size	Accuracy class <sup>1)</sup>	Guide rail one-piece <sup>2)</sup> Part number, Rail length L (mm)	Spacing T <sub>2</sub> (mm)	Recommended rail lengths
				Number of holes n <sub>B</sub> / rail length L (mm)
25	H	1845-263-41, ....	30	according to formula $L = n_B \cdot T_2 - 4$ up to 133/3986 max.
35	H	1845-363-71, ....	40	according to formula $L = n_B \cdot T_2 - 4$ up to 100/3996 max.
45	H	1845-463-71, ....	52.5	according to formula $L = n_B \cdot T_2 - 4$ up to 76/3986 max.
55	H	1845-563-71, ....	60	according to formula $L = n_B \cdot T_2 - 4$ up to 66/3956 max.
65	H	1845-663-71, ....	75	according to formula $L = n_B \cdot T_2 - 4$ up to 53/3971 max.

<sup>1)</sup> Accuracy classes SP and P on request

<sup>2)</sup> Composite guide rails on request

## Dimensions and weights

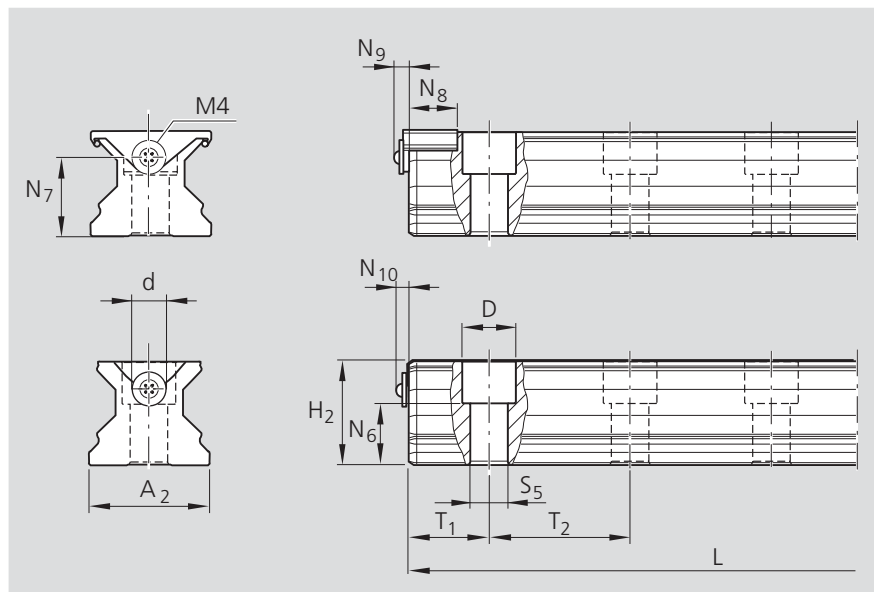

Size	Dimensions (mm)										Weight				
	A <sub>2</sub>	H <sub>2</sub> <sup>1)</sup>	N <sub>6</sub> <sup>±0.5</sup>	N <sub>7</sub>	N <sub>8</sub>	N <sub>9</sub>	N <sub>10</sub>	d	D	S <sub>5</sub>	T <sub>15-1.0</sub> <sup>+0.5/2)</sup>	T <sub>1 min</sub> <sup>3)</sup>	T <sub>2</sub>	L <sub>max</sub>	kg/m
<b>25</b>	23	23.55	14.3	15.0	15.2	6.5	4.10	12	11.0	7.0	13.00	13	30.0	4000	3.1
<b>35</b>	34	31.10	19.4	22.0	18.0	7.0	4.10	15	15.0	9.0	18.00	16	40.0	4000	6.3
<b>45</b>	45	39.10	22.4	30.0	20.0	7.0	4.10	15	20.0	14.0	24.25	18	52.5	4000	10.3
<b>55</b>	53	47.85	28.7	30.0	20.0	7.0	4.35	20	24.0	16.0	28.00	20	60.0	4000	13.1
<b>65</b>	63	58.15	36.5	40.0	20.0	7.0	4.35	20	26.0	18.0	35.50	21	75.0	4000	17.4

- 1) Dimension H<sub>2</sub> with cover strip  
Size 25 with 0.15 mm cover strip  
Sizes 35 to 65 with 0.3 mm cover strip
- 2) Preferred dimension
- 3) Rails with T<sub>1</sub> smaller than T<sub>1 min</sub> have no tap hole at the end face for securing the strip!  
Secure the cover strip!  
Observe mounting instructions!  
The protective cap, washer and screw are included in the supply scope.

# Rexroth Roller Rail Systems

## Standard Guide Rails, Hard Chrome-Plated

### Guide rail 1845-.7.- Hard chrome-plated

For mounting from above,  
for cover strip  
(not included)

- The cover strip and protective caps must be ordered separately. For part numbers and dimensions see "Accessories".

Part numbers / end face coating:

Sizes 25 to 65:

– 1845-...-4. (end faces coated)

### Notes

The mounting holes and the tap holes at the end faces are chrome-plated.

The hard chrome-plated version replaces the zinc-iron coated guide rails.

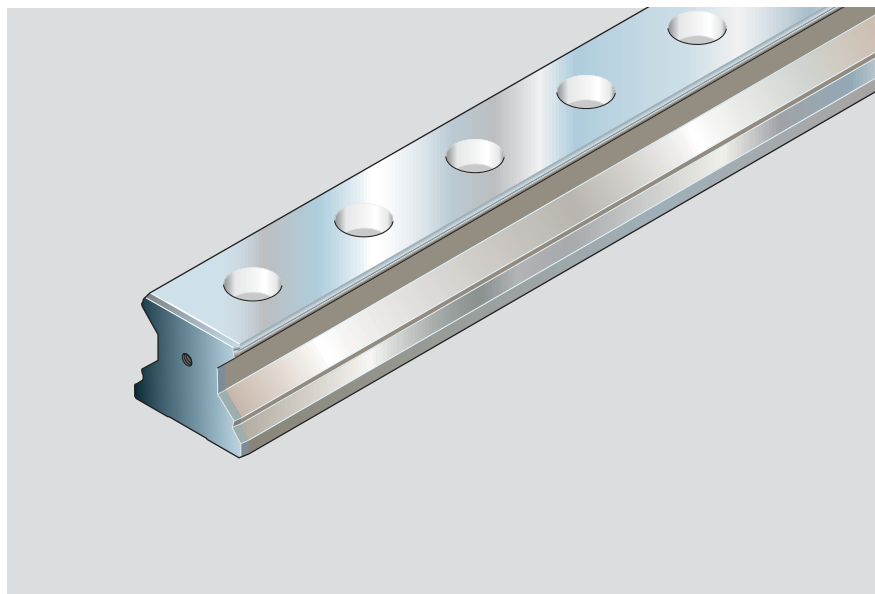

### Part numbers and rail lengths

Size	Accuracy class <sup>1)</sup>	Guide rail one-piece <sup>2)</sup> Part number, Rail length L (mm)	Spacing T <sub>2</sub> (mm)	Recommended rail lengths
				Number of holes n <sub>B</sub> / rail length L (mm)
25	H	1845-273-41, ....	30	according to formula $L = n_B \cdot T_2 - 4$ up to 133/3986 max.
35	H	1845-373-41, ....	40	according to formula $L = n_B \cdot T_2 - 4$ up to 100/3996 max.
45	H	1845-473-41, ....	52.5	according to formula $L = n_B \cdot T_2 - 4$ up to 76/3986 max.
55	H	1845-573-41, ....	60	according to formula $L = n_B \cdot T_2 - 4$ up to 66/3956 max.
65	H	1845-673-41, ....	75	according to formula $L = n_B \cdot T_2 - 4$ up to 53/3971 max.

<sup>1)</sup> Accuracy classes SP and P on request

<sup>2)</sup> Composite guide rails on request



## Dimensions and weights

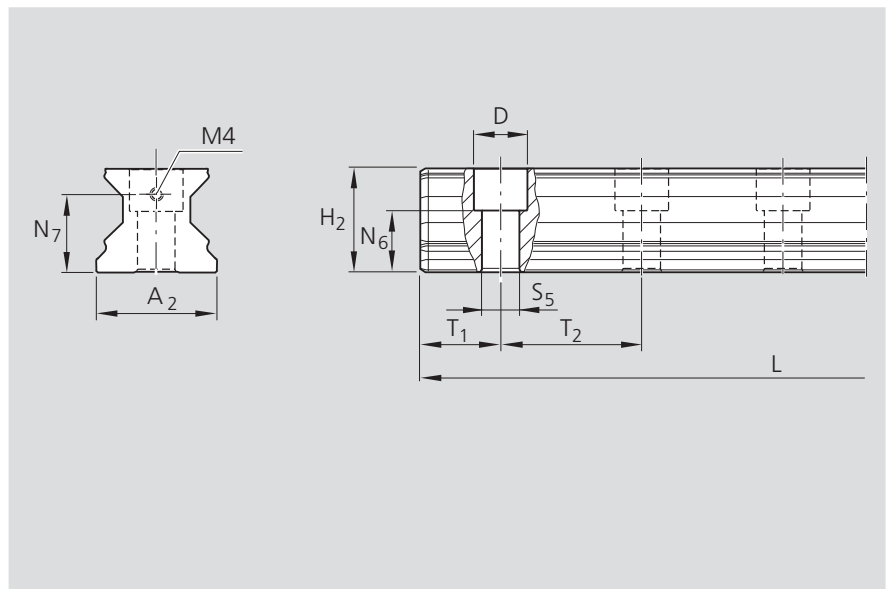

Size	Dimensions (mm)										Weight kg/m
	A <sub>2</sub>	H <sub>2</sub> <sup>1)</sup>	N <sub>6</sub> <sup>±0.5</sup>	N <sub>7</sub>	D	S <sub>5</sub>	T <sub>1S</sub> <sup>+0.5/-1.0</sup> <sup>2)</sup>	T <sub>1min</sub> <sup>3)</sup>	T <sub>2</sub>	L <sub>max</sub>	
25	23	23.40	14.3	15.0	11	7	13.00	13	30.0	4000	3.1
35	34	30.80	19.4	22.0	15	9	18.00	16	40.0	4000	6.3
45	45	38.80	22.4	30.0	20	14	24.25	18	52.5	4000	10.3
55	53	47.55	28.7	30.0	24	16	28.00	20	60.0	4000	13.1
65	63	57.85	36.5	40.0	26	18	35.50	21	75.0	4000	17.4

1) Dimension H<sub>2</sub> without cover strip

2) Preferred dimension

3) Rails with T<sub>1</sub> smaller than T<sub>1min</sub> have no tap hole at the end face for securing the strip!

Secure the cover strip!

Observe mounting instructions!

# Rexroth Roller Rail Systems

## Standard Guide Rails, Hard Chrome-Plated

### Guide rail 1845-.6.- Hard chrome-plated

For mounting from above,  
with cover strip in stainless spring  
steel to EN 10088 and screw-down  
protective caps

Part numbers / end face coating:

Size 25 with 0.15 mm cover strip:  
– 1845-...-4. (end faces coated)

Sizes 35 to 65 with 0.3 mm cover strip:  
– 1845-...-7. (end faces coated)

#### Notes

The mounting holes and the tap holes at  
the end faces are chrome-plated.

The hard chrome-plated version replaces  
the zinc-iron coated guide rails.

Securing with screw and washer to be  
done by the customer. Screw and washer  
are available as accessories.

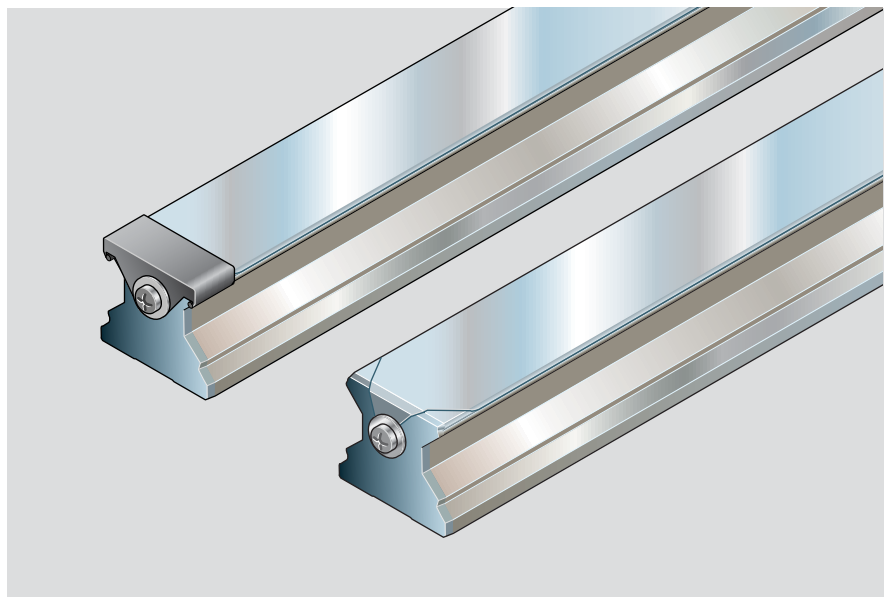

### Part numbers and rail lengths

Size	Accuracy class <sup>1)</sup>	Guide rail one-piece <sup>2)</sup> Part number, Rail length L (mm)	Spacing T <sub>2</sub> (mm)	Recommended rail lengths
				Number of holes n <sub>B</sub> / rail length L (mm)
25	H	1845-263-41, ....	30	according to formula $L = n_B \cdot T_2 - 4$ up to 133/3986 max.
35	H	1845-363-71, ....	40	according to formula $L = n_B \cdot T_2 - 4$ up to 100/3996 max.
45	H	1845-463-71, ....	52.5	according to formula $L = n_B \cdot T_2 - 4$ up to 76/3986 max.
55	H	1845-563-71, ....	60	according to formula $L = n_B \cdot T_2 - 4$ up to 66/3956 max.
65	H	1845-663-71, ....	75	according to formula $L = n_B \cdot T_2 - 4$ up to 53/3971 max.

<sup>1)</sup> Accuracy classes SP and P on request

<sup>2)</sup> Composite guide rails on request

## Dimensions and weights

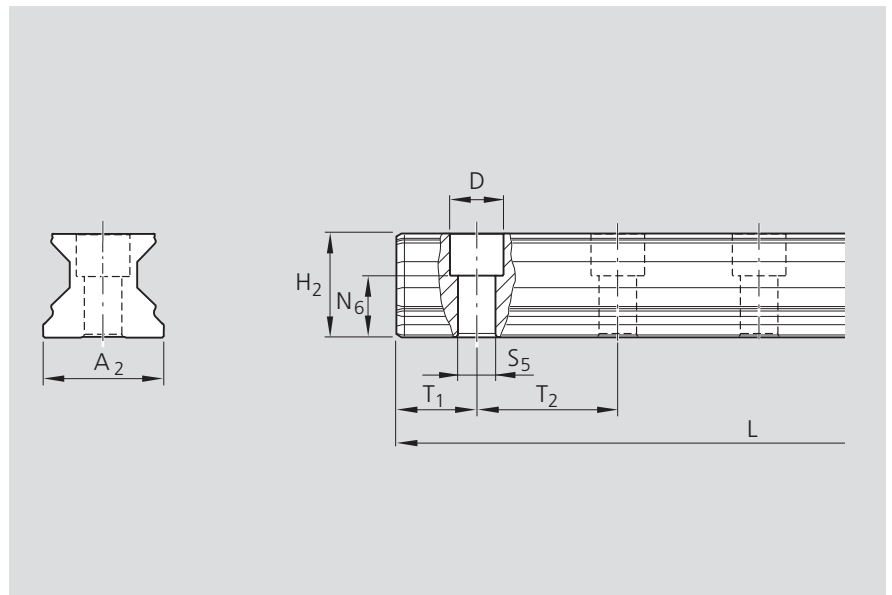

Size	Dimensions (mm)									Weight
	$A_2$	$H_2$	$N_6^{\pm 0.5}$	$D$	$S_5$	$T_{15}^{+0.5^1)$	$T_{1 \min}$	$T_2$	$L_{\max}$	kg/m
<b>25</b>	23	23.40	14.3	11	7	13.00	10	30.0	4000	3.1
<b>35</b>	34	30.80	19.4	15	9	18.00	12	40.0	4000	6.3
<b>45</b>	45	38.80	22.4	20	14	24.25	16	52.5	4000	10.3
<b>55</b>	53	47.55	28.7	24	16	28.00	18	60.0	4000	13.1
<b>65</b>	63	57.85	36.5	26	18	35.50	20	75.0	4000	17.4

<sup>1)</sup> Preferred dimension

# Rexroth Roller Rail Systems

## Standard Guide Rails, Hard Chrome-Plated

### Guide rail 1847-.0.- Hard chrome-plated

#### For mounting from below

Part numbers / end face coating:

Sizes 25 to 65:

– 1847-...-4. (end faces coated)

#### Notes

The mounting holes are chrome-plated.

The hard chrome-plated version replaces the zinc-iron coated guide rails.

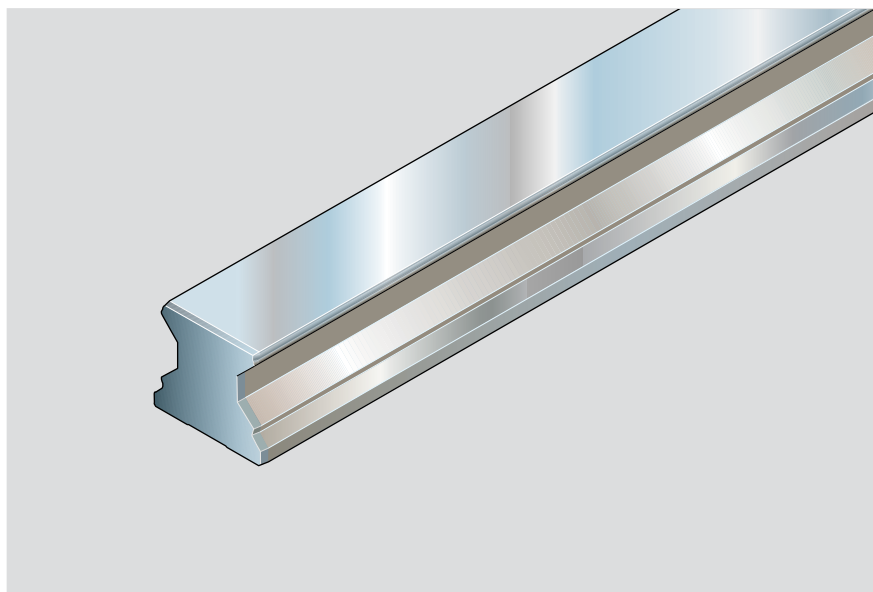

### Part numbers and rail lengths

Size	Accuracy class <sup>1)</sup>	Guide rail one-piece <sup>2)</sup> Part number, Rail length L (mm)	Spacing T <sub>2</sub> (mm)	Recommended rail lengths
				Number of holes n <sub>B</sub> / rail length L (mm)
25	H	1847-203-41, ....	30	according to formula $L = n_B \cdot T_2 - 4$ up to 133/3986 max.
35	H	1847-303-41, ....	40	according to formula $L = n_B \cdot T_2 - 4$ up to 100/3996 max.
45	H	1847-403-41, ....	52.5	according to formula $L = n_B \cdot T_2 - 4$ up to 76/3986 max.
55	H	1847-503-41, ....	60	according to formula $L = n_B \cdot T_2 - 4$ up to 66/3956 max.
65	H	1847-603-41, ....	75	according to formula $L = n_B \cdot T_2 - 4$ up to 53/3971 max.

<sup>1)</sup> Accuracy classes SP and P on request

<sup>2)</sup> Composite guide rails on request

## Dimensions and weights

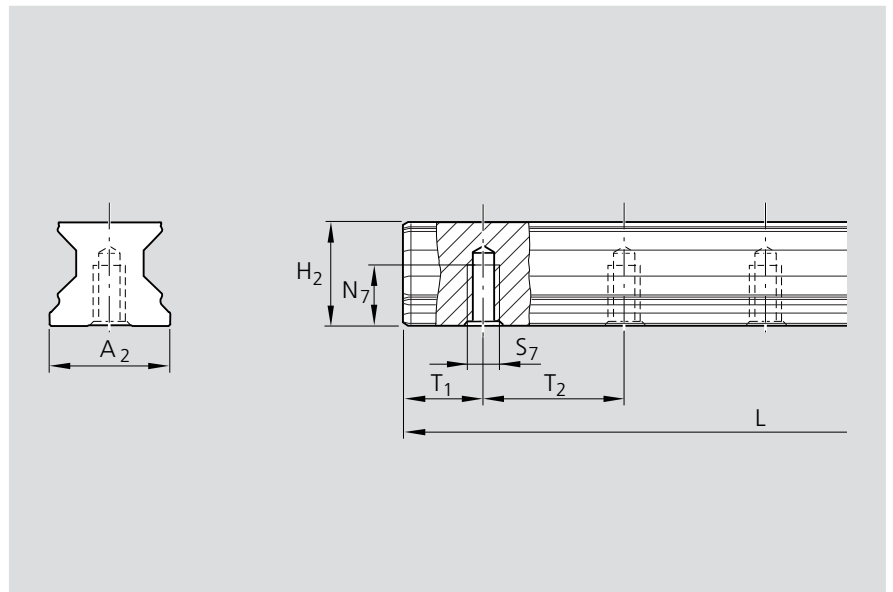

Size	Dimensions (mm)								Weight kg/m
	A <sub>2</sub>	H <sub>2</sub>	N <sub>7</sub> <sup>±0.5</sup>	S <sub>7</sub>	T <sub>1S</sub> <sup>+0.5<sup>1)</sup> -1.0</sup>	T <sub>1 min</sub>	T <sub>2</sub>	L <sub>max</sub>	
<b>25</b>	23	23.40	12	M6	13.00	10	30.0	4000	3.1
<b>35</b>	34	30.80	15	M8	18.00	12	40.0	4000	6.3
<b>45</b>	45	38.80	19	M12	24.25	16	52.5	4000	10.3
<b>55</b>	53	47.55	22	M14	28.00	18	60.0	4000	13.1
<b>65</b>	63	57.85	25	M16	35.50	20	75.0	4000	17.4

<sup>1)</sup> Preferred dimension

# Rexroth Roller Rail Systems

## Product Overview – Wide Steel Runner Blocks

Very high torque capacity and torsional rigidity

**Make up your own compact linear motion guideways from interchangeable standard stock elements...**

Rexroth fabricates its guide rails and runner blocks with such high precision that each individual component element can be replaced by another at any time. This makes infinite combinations possible. Each element can be individually ordered and separately stocked.

- Both sides of the guide rail can be used as reference edges.
- Four reference edges on runner block for precise alignment in machine structure.
- Lube ports on all sides for maximum ease of maintenance.
- Novel lube duct design minimizes lubricant consumption.
- Innovative cage design allows for longer lubrication intervals.
- Smooth running thanks to optimized roller recirculation and guidance.
- Mounting of attachments to runner block from above or below.
- Improved rigidity under lift-off and side loading conditions through four additional mounting screw holes at the center of the runner block.
- Optimized entry-section geometry and high number of rollers per track minimizes variation in elastic deflection.
- Integrated all-round sealing.
- End seal as standard.
- Aluminum end caps.

For high moment loads and enhanced rigidity:

**Rexroth Wide Roller Rail Systems**

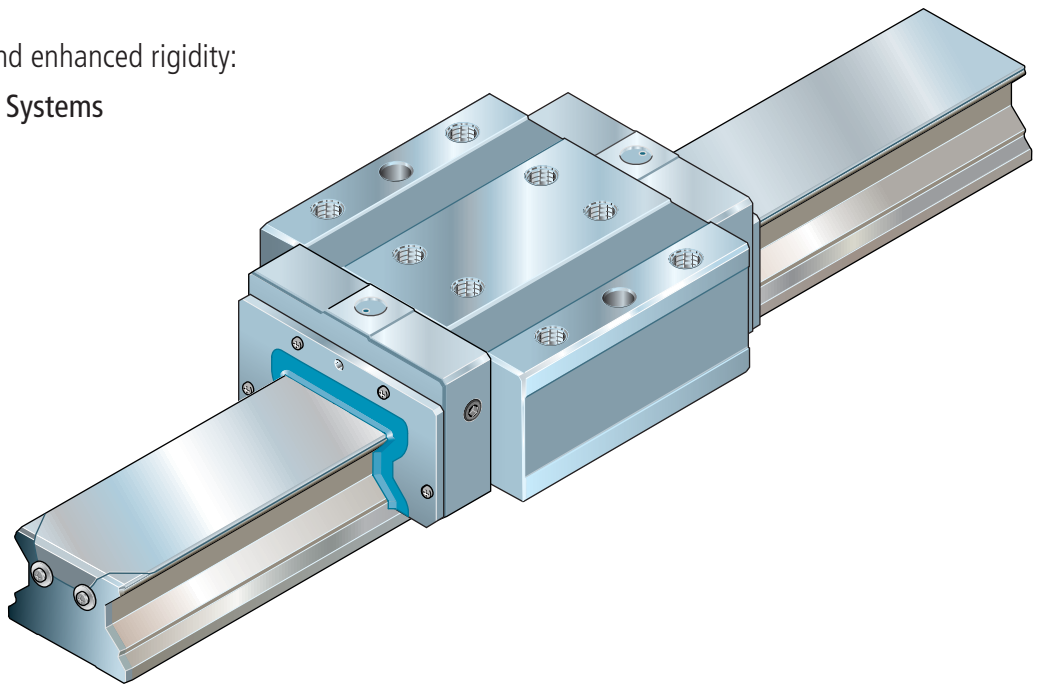

Proven cover strip for guide rail mounting holes:

- A *single* cover for all holes
- Stainless spring steel to EN 10088
- Easy to fit – simply clip on and secure

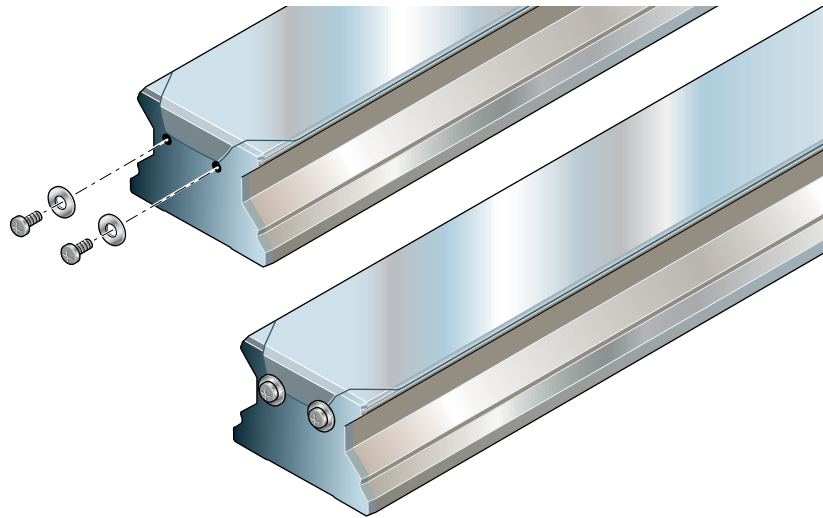

# Rexroth Roller Rail Systems

## Product Description – Wide Steel Runner Blocks

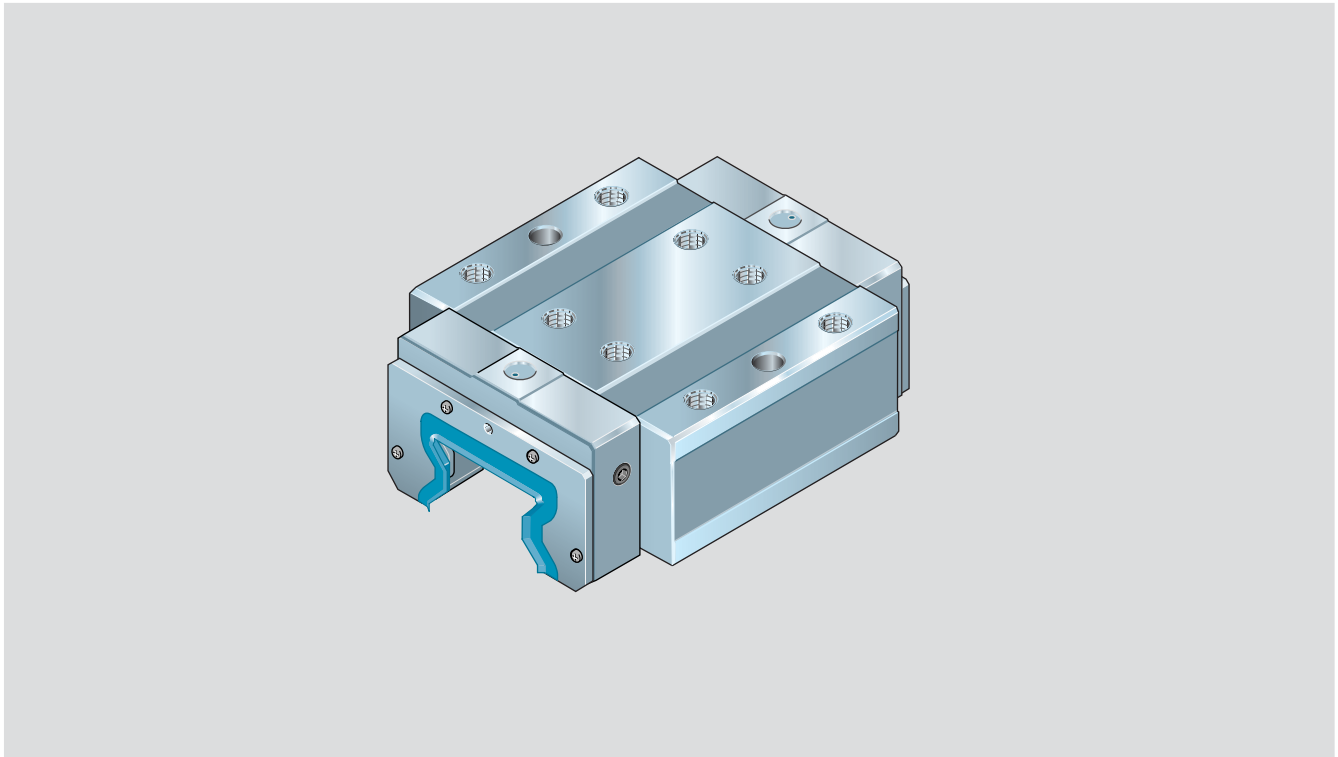

### The Roller Rail Systems consist of:

- guide rail, all surfaces ground, hardened bearing surfaces
- runner block of anti-friction bearing steel, hardened and ground raceways, with:
  - rollers made of anti-friction bearing steel
  - cage designed for optimum roller recirculation
  - fully sealed roller raceways
  - two end seals for better sealing and to protect plastic parts
  - two reference edges on both sides
  - aluminum end caps.

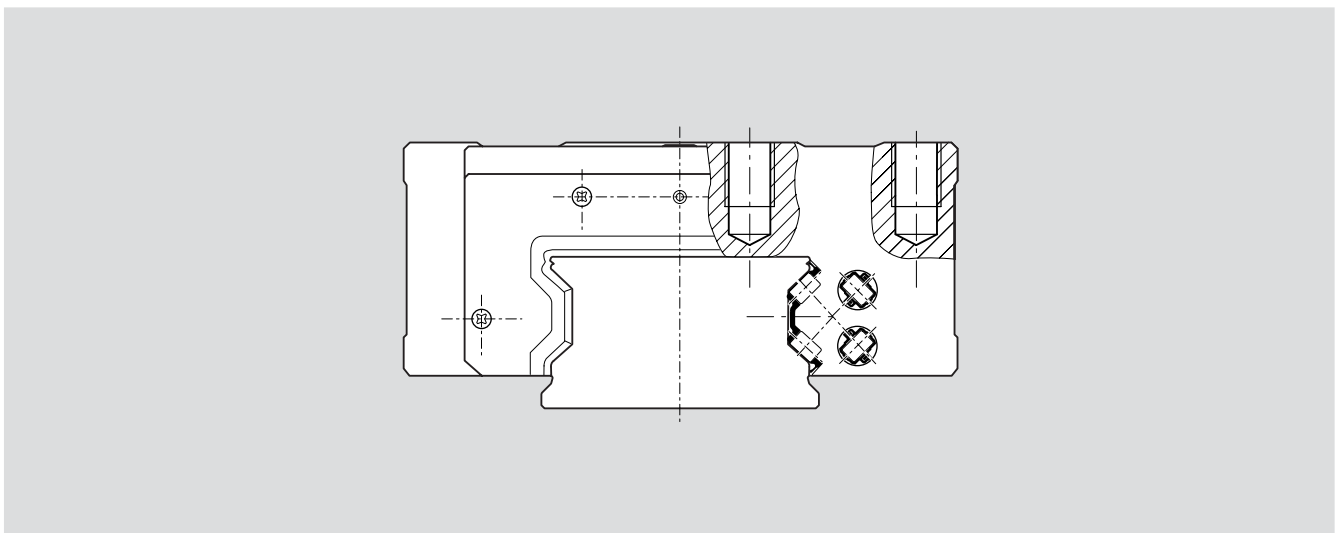



# Technical Data – Wide Steel Runner Blocks

## Accuracy classes and their tolerances

Wide Roller Rail Systems are available in 3 different accuracy classes.

For available versions see "Part number" tables.

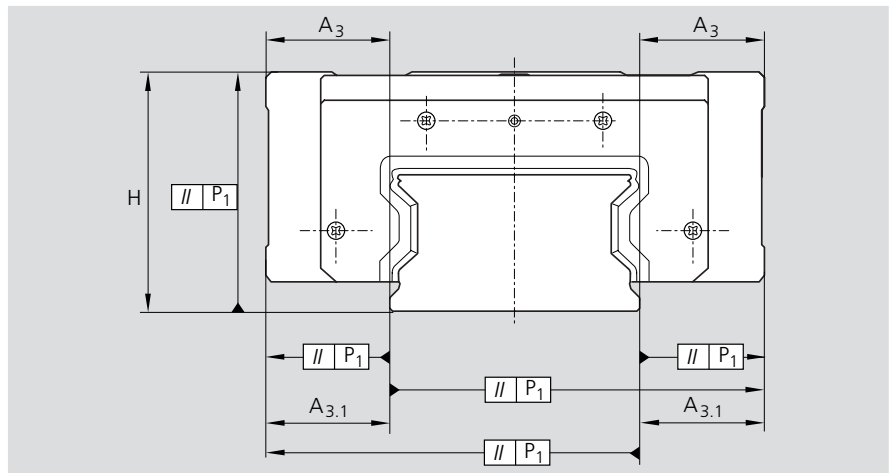

## Built-in interchangeability due to precision machining

Rexroth machines its guide rails and runner blocks, and the roller raceways in particular, with such high precision that each individual element is interchangeable.

Any runner block can be combined with any guide rail of the same size. It is also possible to install several different runner blocks on the same guide rail.

## Wide steel runner blocks

Accuracy classes	Dimensional tolerances (µm)			Max. difference in dimensions H and A <sub>3</sub> on the same guide rail	
	H	A <sub>3</sub>	A <sub>3.1</sub>	Δ H, Δ A <sub>3</sub> (µm)	Δ A <sub>3.1</sub> (µm)
SP	± 10	± 7	+ 12 - 10	5	7
P	± 20	± 10	+ 15 - 13	7	9
H	± 40	± 20	+ 26 - 24	15	17

## Special versions: hard chrome-plated

	H		A <sub>3</sub>		A <sub>3.1</sub>		Δ H, Δ A <sub>3</sub> (µm)		Δ A <sub>3.1</sub> (µm)	
	RB/GR	GR	RB/GR	GR	RB/GR	GR	RB/GR	GR	RB/GR	GR
SP	+ 17 - 8	+ 14 - 9	± 10	+ 6 - 11	+ 15 - 13	+ 11 - 14	8	5	10	7
P	+ 27 - 18	+ 24 - 19	± 13	+ 9 - 14	+ 18 - 16	+ 14 - 17	10	7	12	9
H	+ 47 - 38	+ 44 - 39	± 23	+ 19 - 24	+ 29 - 27	+ 25 - 28	18	15	20	17

## Abbreviations

RB/GR = runner block and guide rail  
hard chrome-plated  
GR = only the guide rail is hard chrome-plated

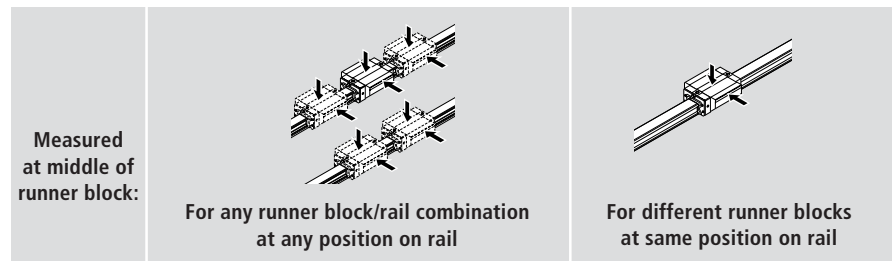

## Parallelism offset P<sub>1</sub> of Roller Rail Systems when properly installed

### Measured at middle of runner block

Values apply to roller rail systems without surface coating.

With hard chrome-plated guide rails, the values may increase by up to 2 µm.

### Legend

P<sub>1</sub> = parallelism offset  
L = rail length

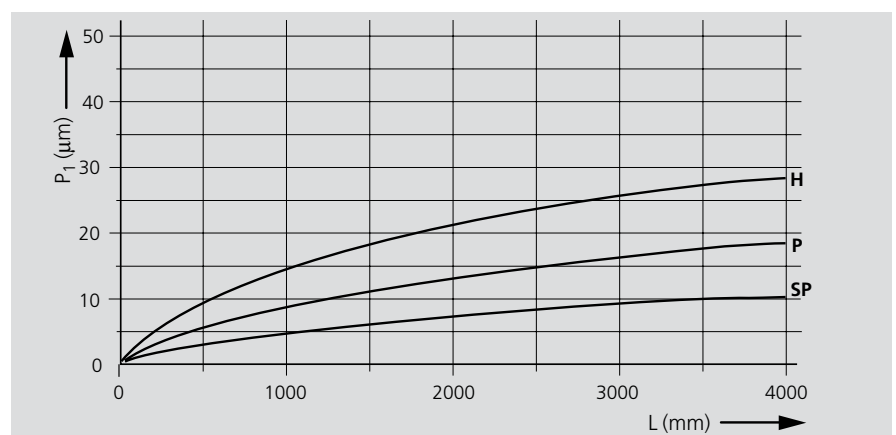

# Rexroth Roller Rail Systems

## Technical Data – Wide Steel Runner Blocks

### Rigidity of the Roller Rail System at 0.13 C preload

Wide runner block 1872-  
Size 55/85

————— calculated values  
Runner block mounted using 8 screws  
and the upper reference edges only:  
– all screws of strength class 12.9

#### 1. Down load

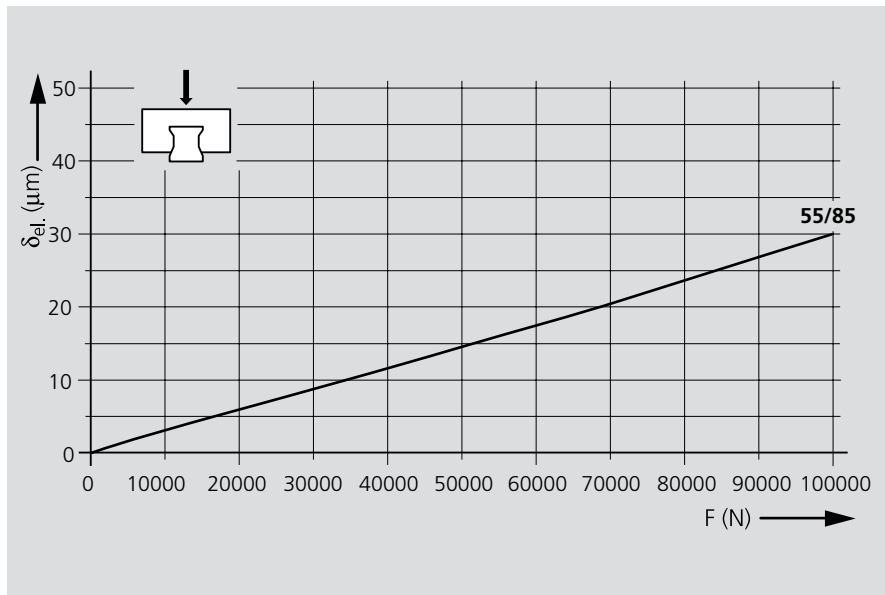

#### 2. Lift-off load

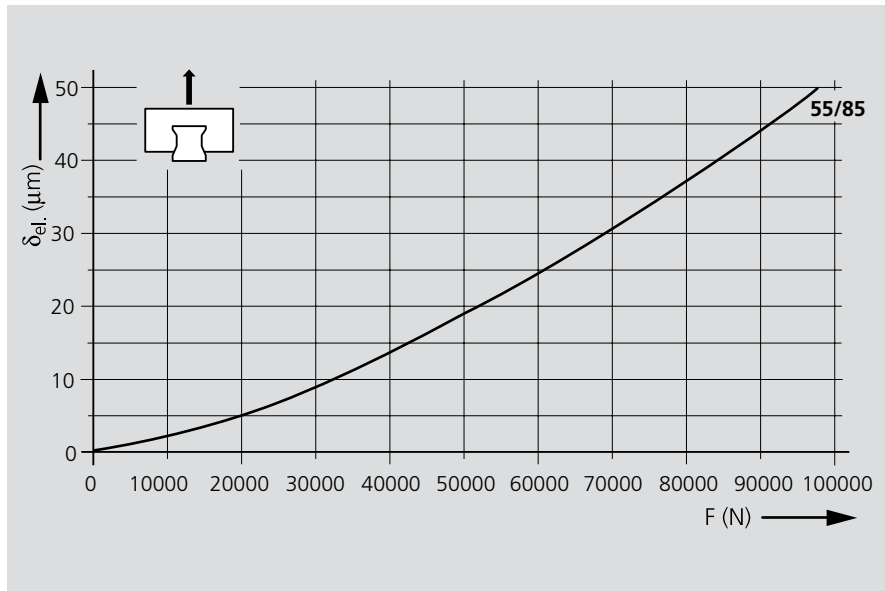

#### 3. Side load

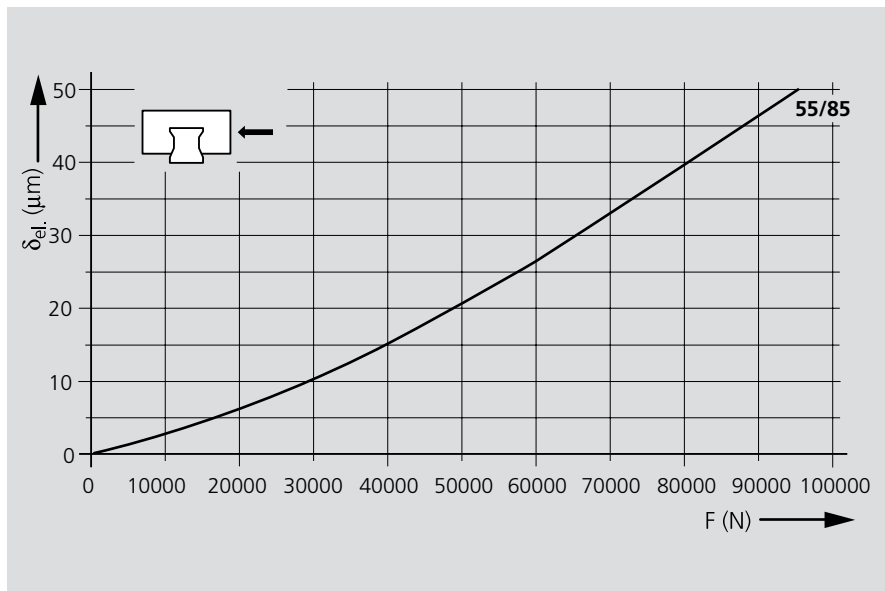

#### Legend

$\delta_{el}$  = elastic deflection  
F = load

## Rigidity of the Roller Rail System at 0.13 C preload

Wide runner block 1872-  
Size 55/85

————— calculated values  
Runner block mounted using 8 screws  
and all 4 reference edges (top and  
bottom):  
– all screws of strength class 12.9

### 1. Down load

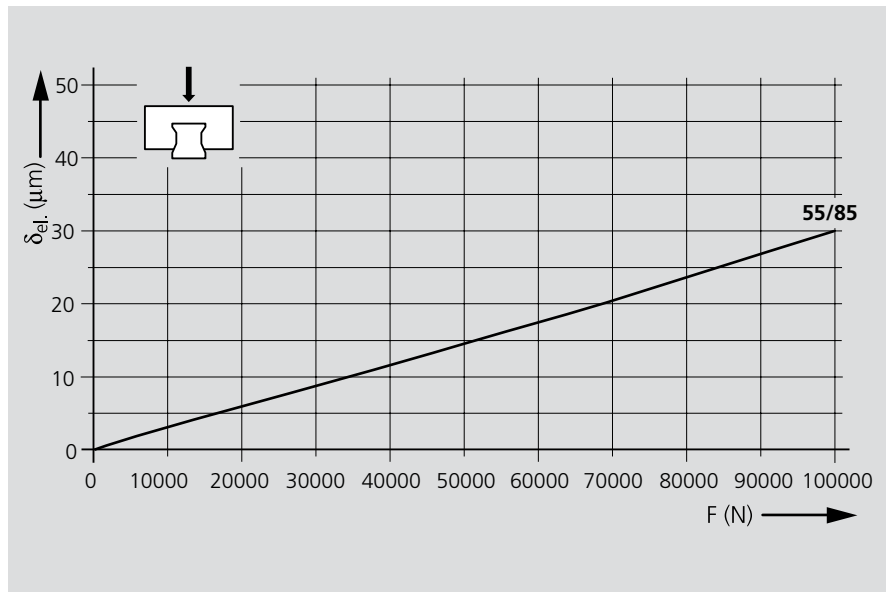

### 2. Lift-off load

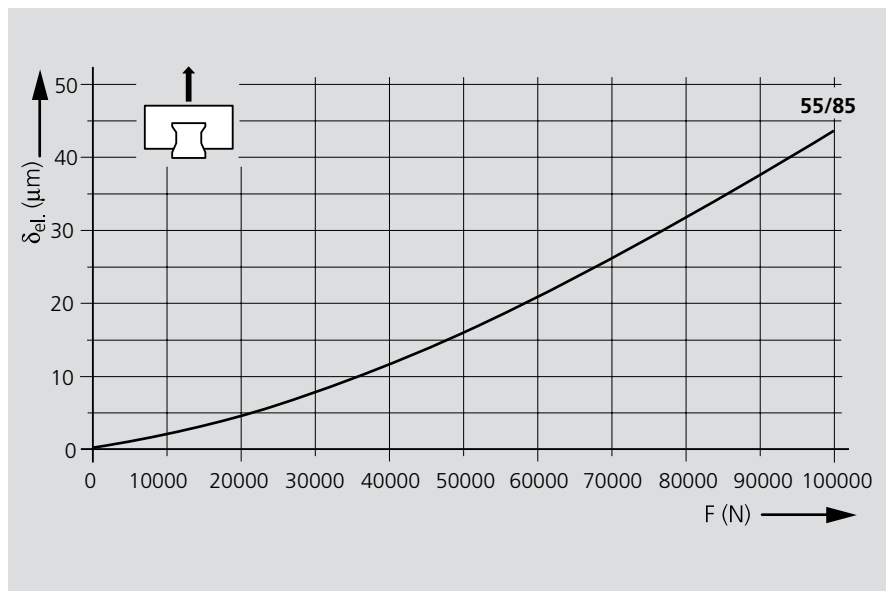

### 3. Side load

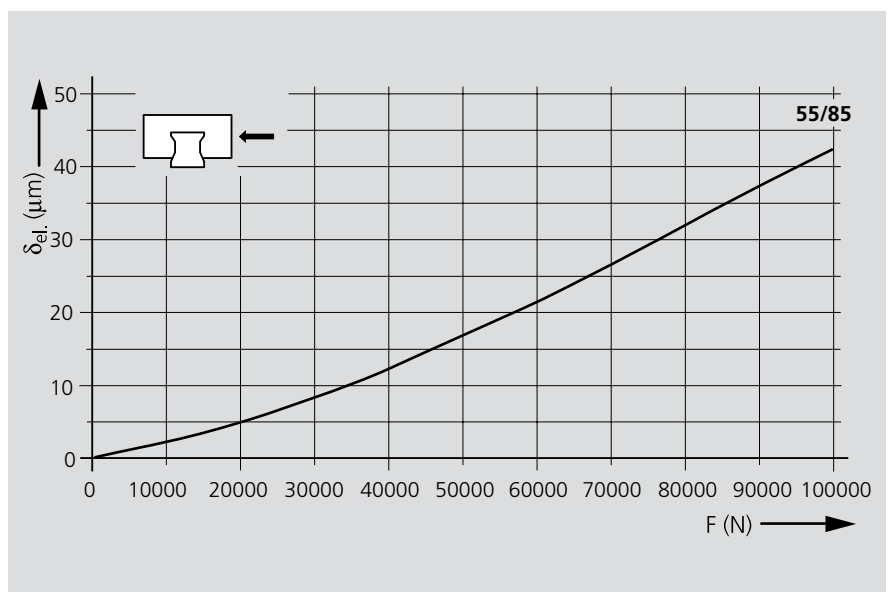

#### Legend

$\delta_{el.}$  = elastic deflection  
F = load

# Rexroth Roller Rail Systems

## Technical Data – Wide Steel Runner Blocks

### Rigidity of the Roller Rail System at 0.13 C preload

Wide runner block 1872-  
Size 65/100

————— calculated values  
Runner block mounted using 8 screws  
and the upper reference edges only:  
– all screws of strength class 12.9

#### 1. Down load

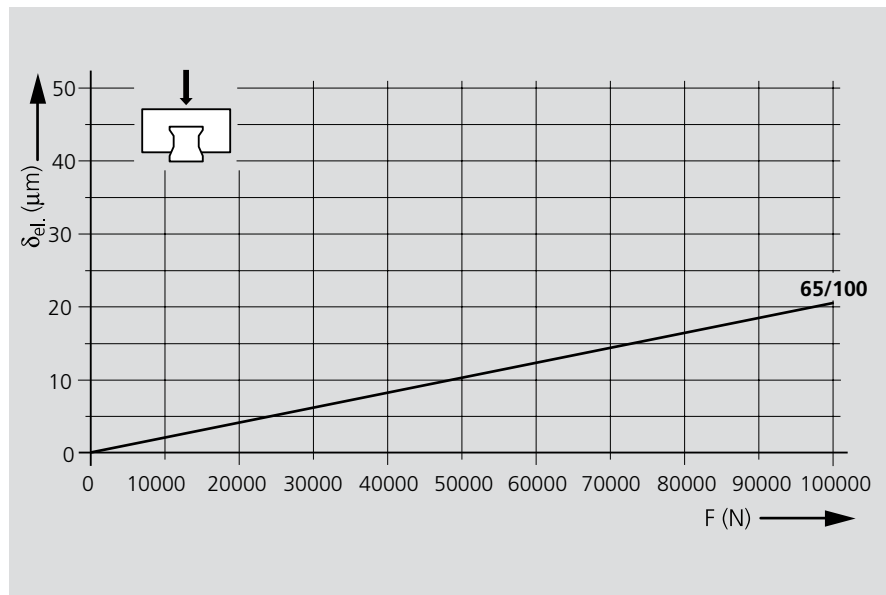

#### 2. Lift-off load

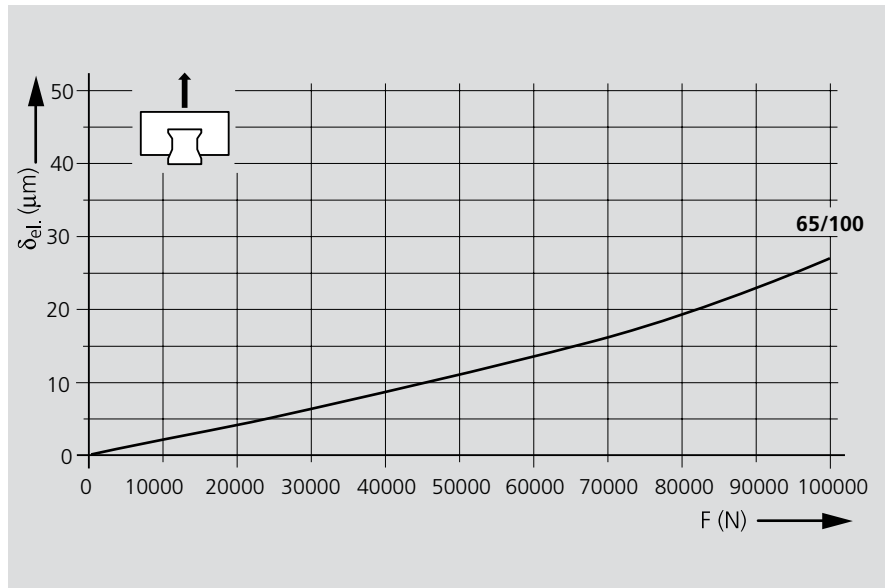

#### 3. Side load

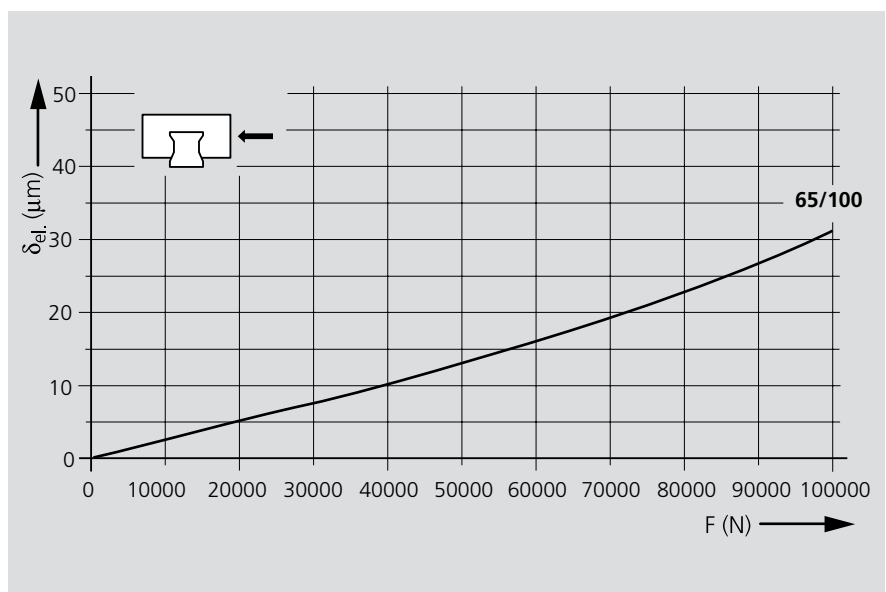

#### Legend

$\delta_{el.}$  = elastic deflection  
 $F$  = load

## Rigidity of the Roller Rail System at 0.13 C preload

Wide runner block 1872-  
Size 65/100

————— calculated values  
Runner block mounted using 8 screws  
and all 4 reference edges (top and  
bottom):

– all screws of strength class 12.9

### 1. Down load

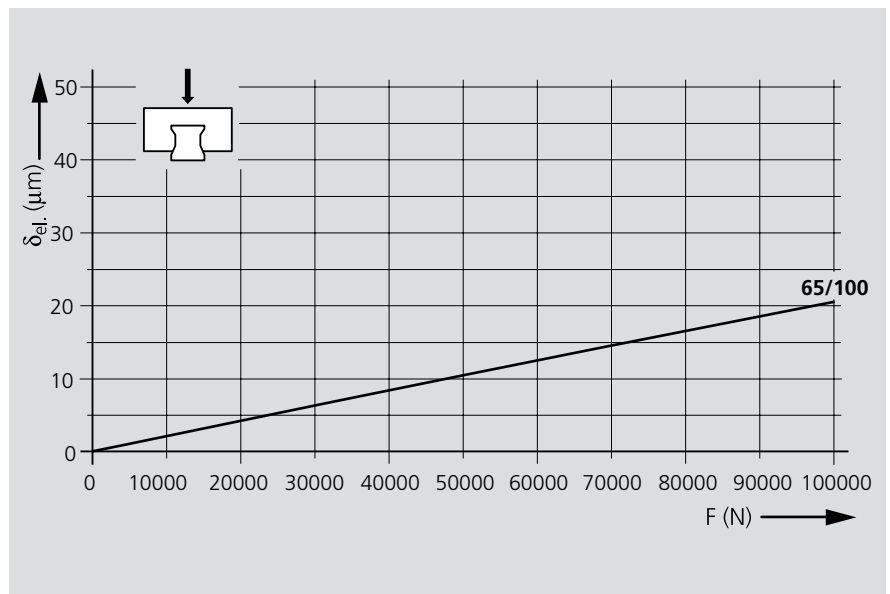

### 2. Lift-off load

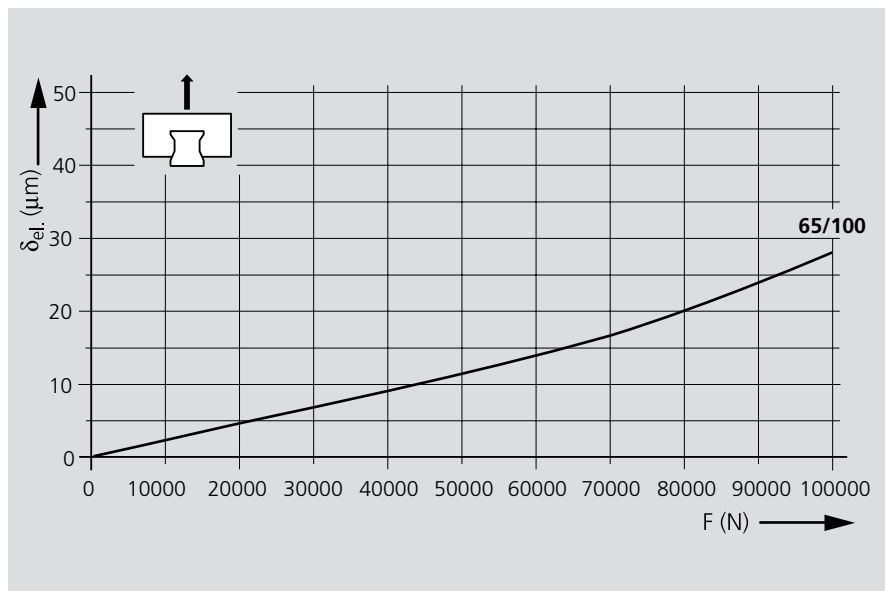

### 3. Side load

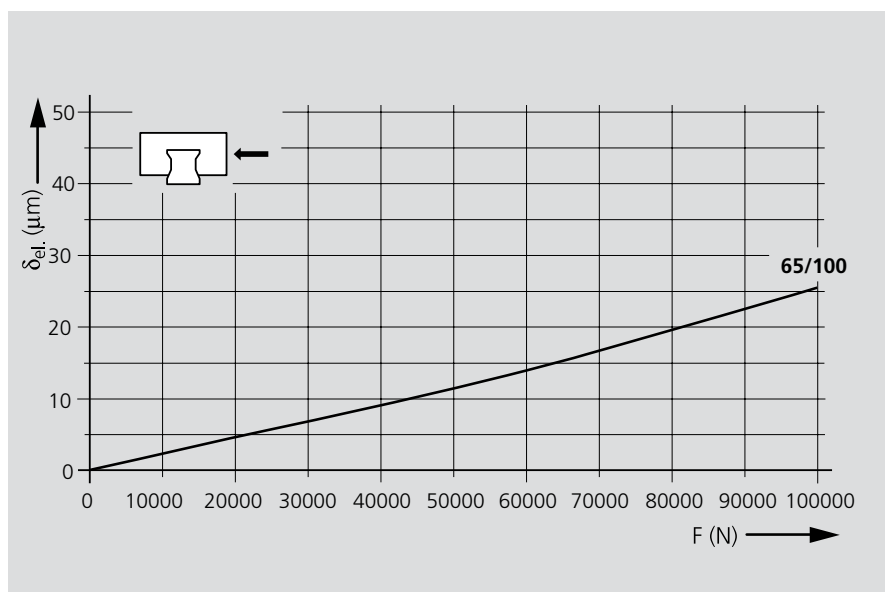

#### Legend

$\delta_{el.}$  = elastic deflection

F = load

# Rexroth Roller Rail Systems

## Mounting Instructions for Wide Roller Rail Systems

### Reference edges, corner radii, screw sizes and tightening torques

The recommended limits for permissible side loads **without additional lateral retention** indicate the approximate upper limits for screws in two strength classes. In other cases, the permissible side load must be calculated from the screw tension force. This can be up to about 15% less when using screws in strength class 10.9 instead of 12.9.

**⚠** Always check the strength factor of the screws in the case of high lift-off loads!

See "Load on the screw connections between the guide rail and the mounting base".

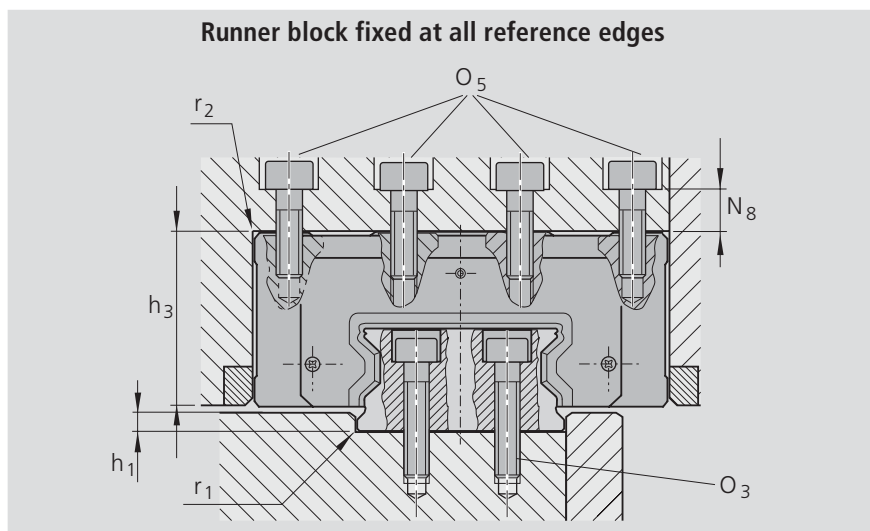
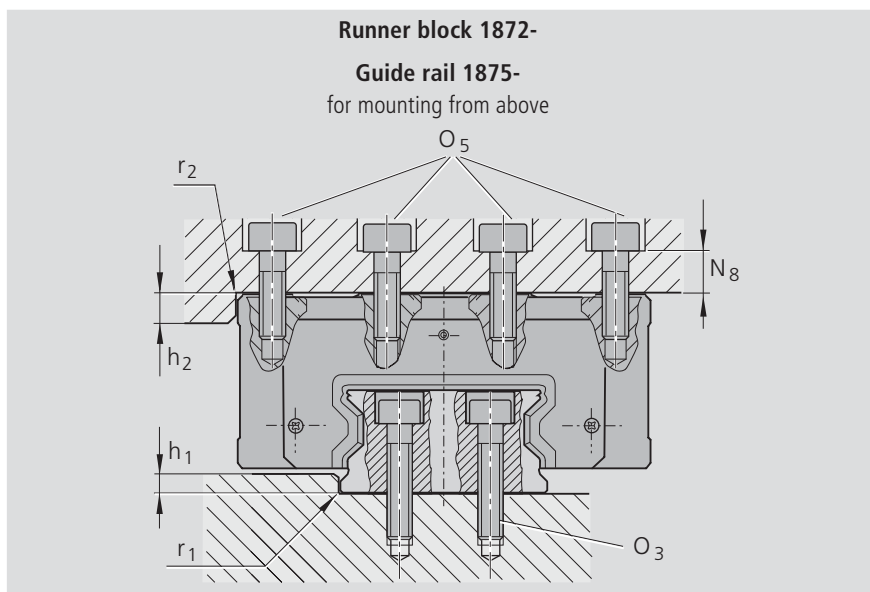

Make sure there is no clearance between reference edges and mating surfaces.



### Dimensions and recommended limits for permissible side loads without additional lateral retention

- 1) For runner block mounting with 8 screws
- 2) Calculated with friction coefficient  $\mu = 0.12$

Size	$h_1$		$r_1$ max. (mm)	$h_2$ (mm)	$h_3$ (mm)	$r_2$ max. (mm)	$O_3$ DIN 912	$O_5$ DIN 912 8 screws	$N_8$ (mm)
	min. (mm)	max. (mm)							
55/85	7.0	9.0	1.2	10	84	1.0	M12x50	M12x30	14
65/100	7.0	9.0	1.2	14	66.5	1.0	M14x60	M14x35	20

Screw strength class	Permissible side load if no lateral retention is provided <sup>2)</sup>		
	Runner block	Rail	
	8.8	0.16 C	0.16 C <sup>1)</sup>
12.9	0.27 C	0.27 C <sup>1)</sup>	

### Tightening torques for mounting screws

	M12	M14
	80	125
 Nm	110	180
	135	215

## Mounting instructions for composite guide rails

### Note on cover strip

For composite rails, a cover strip to cover the total length L is supplied separately along with the rails.

### Rails made up of two sections

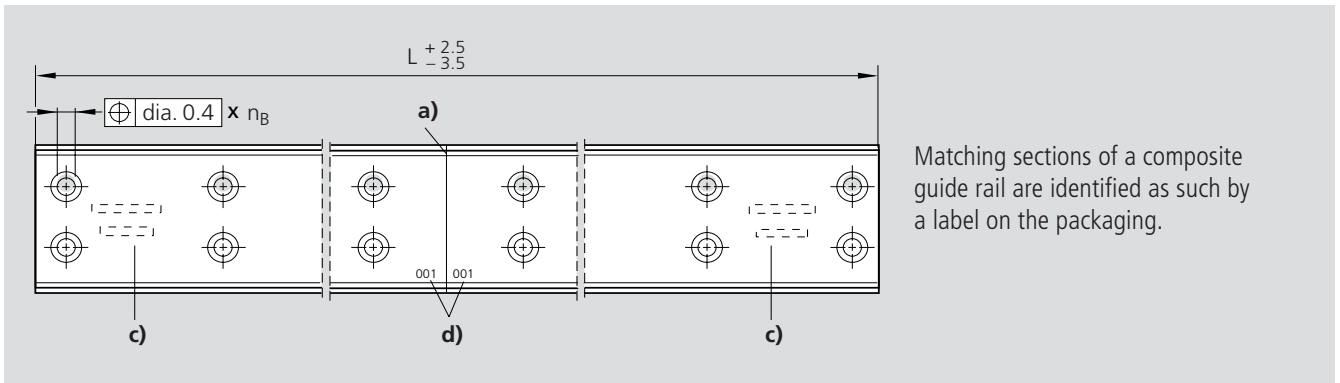

### Rails made up of three or more sections

All sections of the same rail have the same number, which is marked on the top of the guide rail.

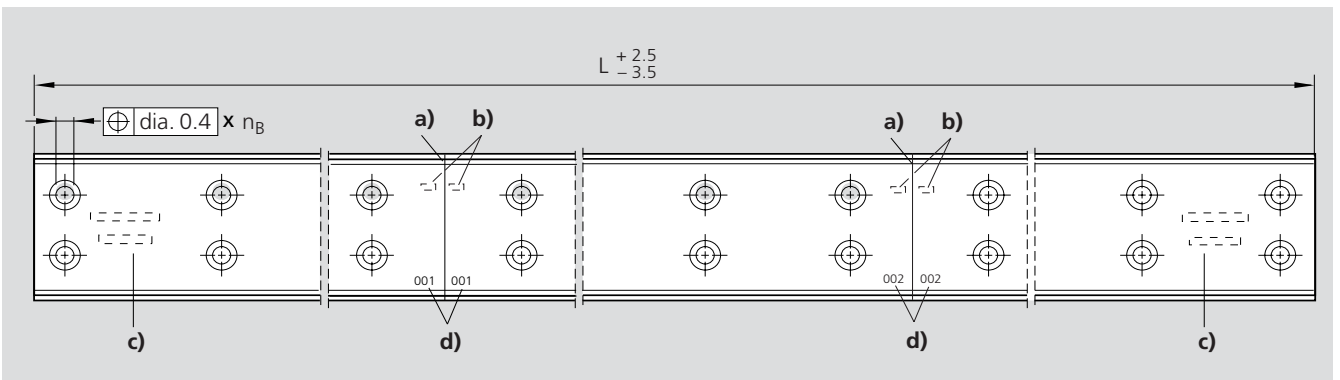

$n_B$  = number of holes

- a) Joint
- b) Rail number
- c) Full rail identification on first and last sections
- d) Joint number

### New: Adjusting shaft

The sections of composite rails can be aligned with the aid of an adjusting shaft. For more detailed information see "Accessories" and the Instructions for Roller Rail Systems.

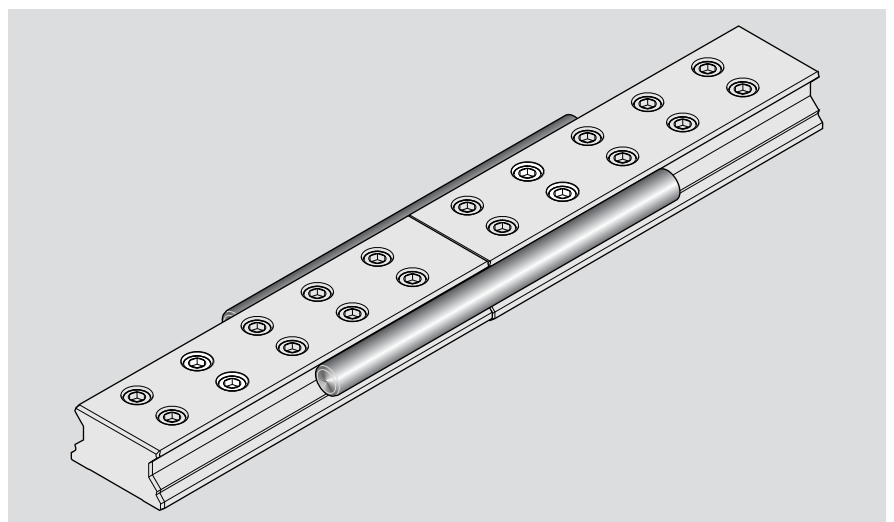

# Rexroth Roller Rail Systems

## Wide Steel Runner Blocks

### Runner block 1872-

#### Wide

Special versions:

- hard chrome-plated

The part numbers for these versions are given in separate tables.

#### Mounting instructions

Mount the cover strip on the guide rail. Grease or oil the runner block seal and the bevels at the rail end. Then carefully slide the runner block onto the guide rail.

For initial and relubrication see the "Lubrication" section.

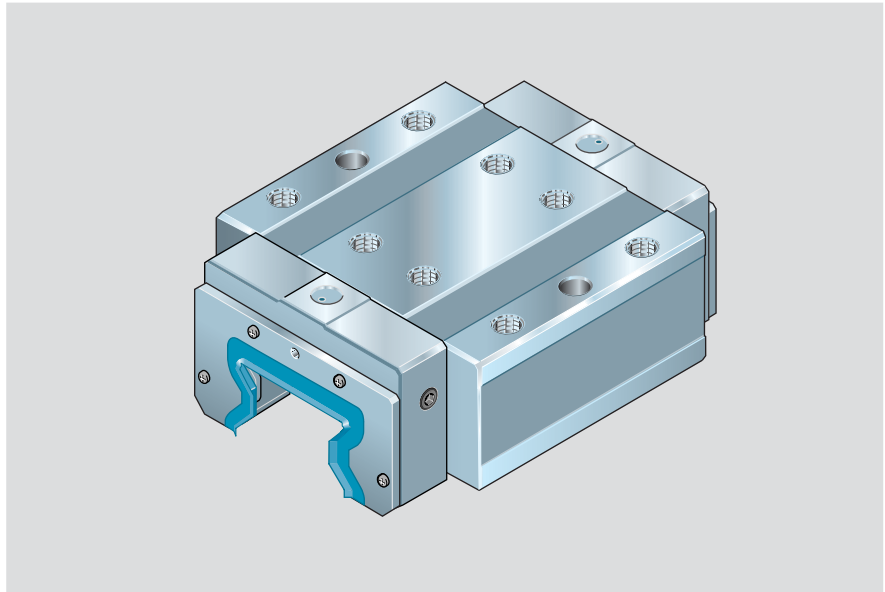

#### Part numbers

Size	Accuracy class	Part numbers for runner blocks with preload class	
		Preload 0.08 C	Preload 0.13 C
55/85	SP	1872-521-10	1872-531-10
	P	1872-522-10	1872-532-10
	H	1872-523-10	–
65/100	SP	1872-621-10	1872-631-10
	P	1872-622-10	1872-632-10
	H	1872-623-10	–

#### Hard chrome-plated

Note: For tolerances other than those specified here for dimensions H and A<sub>3</sub>, see the table of accuracy classes and their tolerances in the "Technical Data" section.

Combining a hard chrome-plated runner block with a hard chrome-plated guide rail results in a preload of approx. 0.1 C.

Size	Accuracy class	Part numbers for hard chrome-plated runner blocks with preload class	
		Preload 0.08 C	Preload 0.13 C
55/85	H	1872-523-60	–
65/100	H	1872-623-60	–

#### Load capacities and moments

##### Note on dynamic load capacities and moments

The dynamic load capacities and moments are based on 100,000 m travel.

However, a travel of just 50,000 m is often taken as a basis. If this is the case, for comparison purposes:

Multiply values **C**, **M<sub>t</sub>** and **M<sub>L</sub>** from the Rexroth table by 1.23.

Size	Load capacities (N)		Moments (Nm)			
	C dyn.	C <sub>0</sub> stat.	M <sub>t</sub> dyn.	M <sub>t0</sub> stat.	M <sub>L</sub> dyn.	M <sub>L0</sub> stat.
55/85	165000	345300	7450	15650	4030	8440
65/100	265500	525600	14300	28350	7960	15760



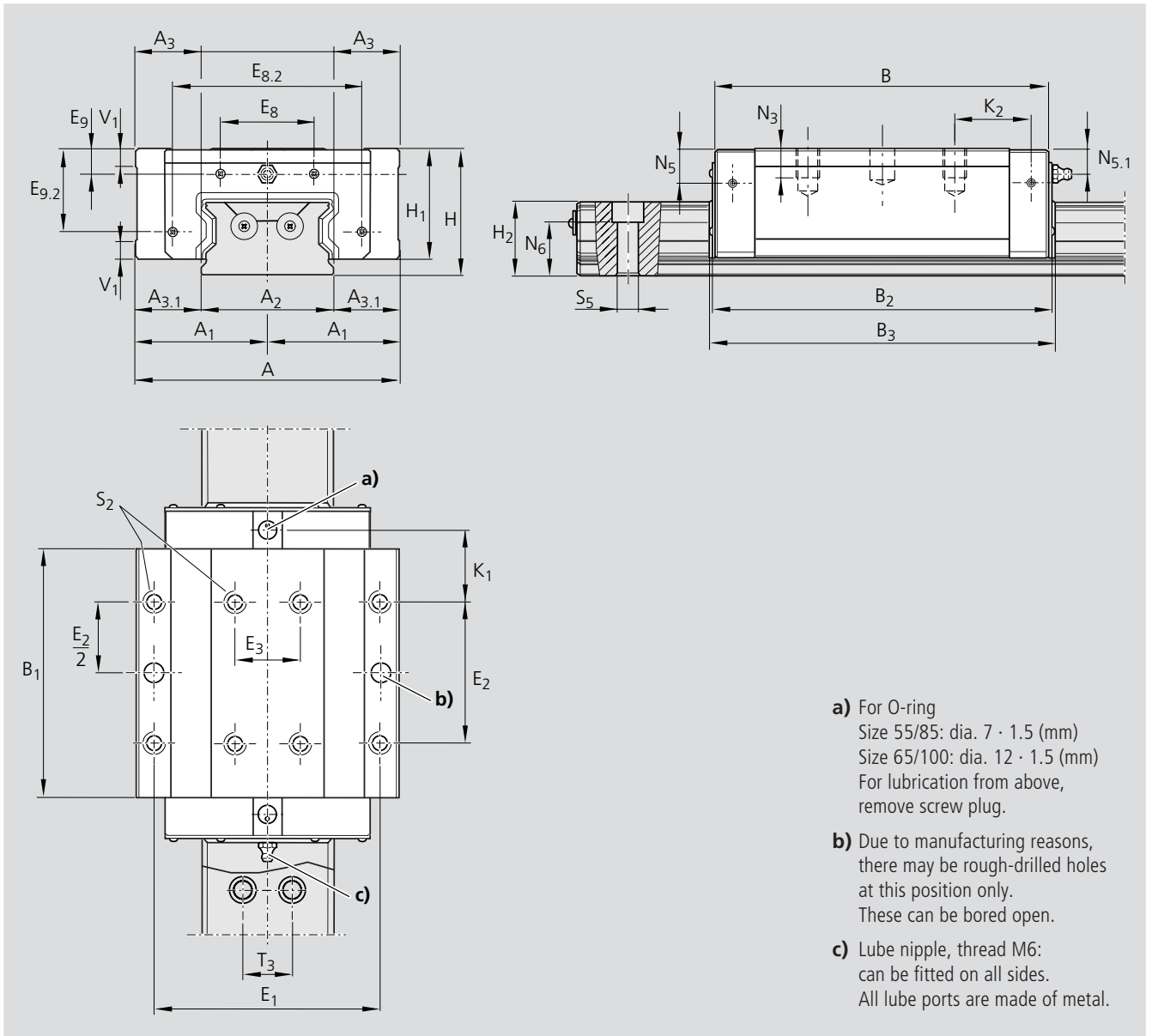

Size	Dimensions (mm)																	
	A	A <sub>1</sub>	A <sub>2</sub>	A <sub>3</sub>	A <sub>3.1</sub>	B	B <sub>1</sub>	B <sub>2</sub>	B <sub>3</sub>	H	H <sub>1</sub>	H <sub>2</sub> <sup>1)</sup>	V <sub>1</sub>	T <sub>3</sub>	E <sub>1</sub>	E <sub>2</sub>	E <sub>3</sub>	
55/85	165	82.5	85	40	40	205.5	162.1	209.5	216	80	68	47.85	12	32		140	95	40
65/100	200	100	100	50	50	254	194	258	264	100	86	58.15	15	38		172	110	50

Size	Dimensions (mm)												Weight	
	E <sub>8</sub>	E <sub>8.2</sub>	E <sub>9</sub>	E <sub>9.2</sub>	N <sub>3</sub>	N <sub>5</sub>	N <sub>5.1</sub>	N <sub>6</sub> <sup>±0.5</sup>	S <sub>2</sub>	S <sub>5</sub>	K <sub>1</sub>	K <sub>2</sub>	(kg)	
55/85	40	113.6	10.75	50.75	19	19	19	31.2	M12	14	43.55	46.55	11.5	
65/100	72	143	19.3	65	20	27	19.3	39	M14	16	55	59	20.7	

<sup>1)</sup> Dimension H<sub>2</sub> with cover strip

# Rexroth Roller Rail Systems

## Wide Guide Rails

### Guide rail 1875-

With double-row mounting hole pattern, for mounting from above, with cover strip of stainless spring steel

Special versions:

- hard chrome-plated

The part numbers for these versions are given on separate pages at the end of this section.

Observe the mounting instructions!

Send for the publication "Mounting Instructions for the Cover Strip".

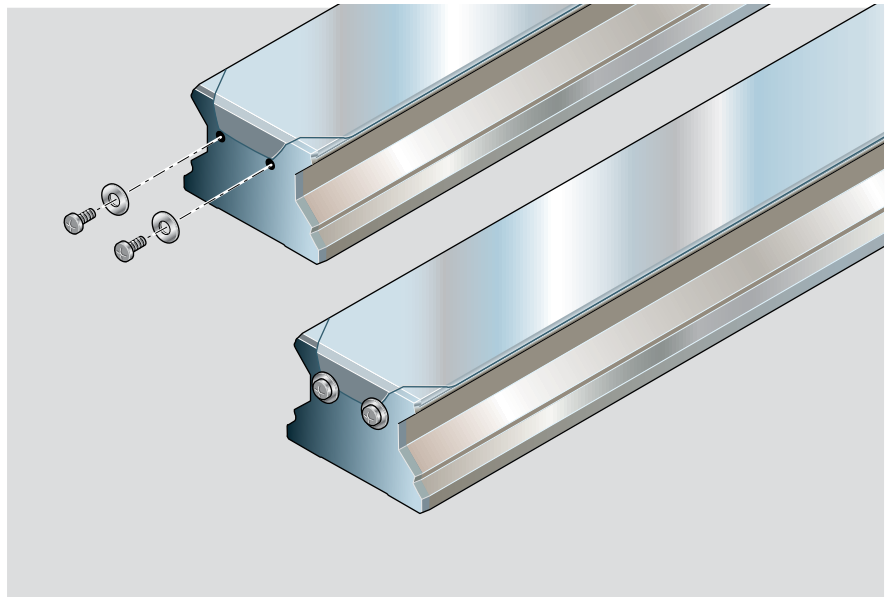

### Part numbers and rail lengths

Size	Accuracy class	Guide rail with cover strip	
		one-piece Part number, Rail length L (mm)	composite Part number, Number of sections, Rail length L (mm)
55/85	SP	1875-561-61, ....	1875-561-6., ....
	P	1875-562-61, ....	1875-562-6., ....
	H	1875-563-61, ....	1875-563-6., ....
65/100	SP	1875-661-61, ....	1875-661-6., ....
	P	1875-662-61, ....	1875-662-6., ....
	H	1875-663-61, ....	1875-663-6., ....

### Recommended rail lengths

Size	Spacing $T_2$ (mm)	Recommended rail lengths Number of holes $n_B$ / rail length L (mm)
55/85	60	according to formula $L = n_B \cdot T_2 - 4$ up to 66/3956 max.
65/100	75	according to formula $L = n_B \cdot T_2 - 4$ up to 53/3971 max. <sup>1)</sup>

<sup>1)</sup> Accuracy classes P and H up to 80/5996 max.; accuracy class SP on request.

## Dimensions and weights

- 1) Dimension  $H_2$  with 0.3 mm cover strip
- 2) Rails with  $T_1$  smaller than  $T_{1\min}$  have no tap hole at the end face for securing the strip!  
Secure the cover strip!  
Observe mounting instructions!  
The washer and screw are included in the supply scope.

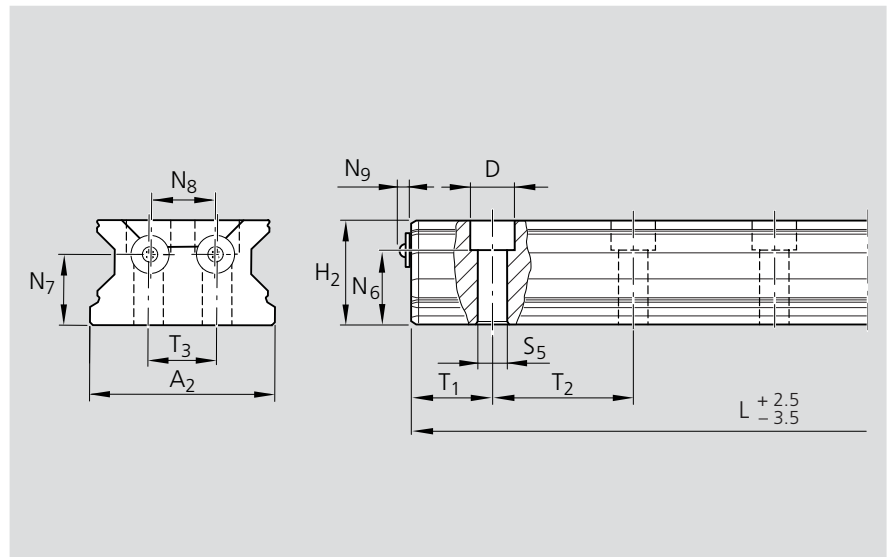

Size	Dimensions (mm)													Weight (kg/m)
	$A_2$	$H_2^{1)}$	$N_6^{\pm 0.5}$	$N_7$	$N_8$	$N_9$	$D$	$S_5$	$T_{15}^{+1.5}_{-1.5}$	$T_{1\min}$	$T_2$	$T_3$	$L_{\max}$	
55/85	85	47.85	31.2	30	32	4.8	20	14	28.0	18	60	32	4000	24.62
65/100	100	58.15	39	40	37	4.8	24	16	35.5	20	75	38	6000	34.68

## Ordering guide rails in recommended lengths

The following examples apply to all guide rail orders. Recommended rails lengths are delivered with priority.

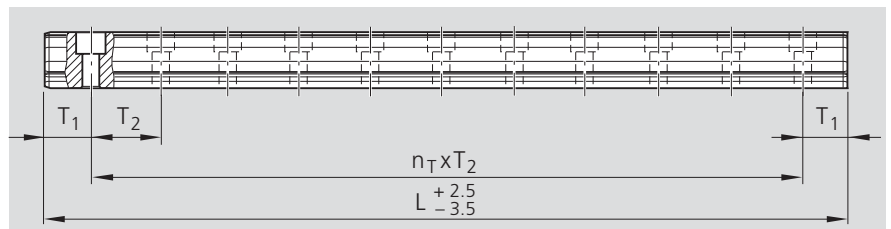

### From the desired length to the recommended length

$$L = \left( \frac{\text{desired length } L}{\text{hole spacing } T_2} \right)^* \cdot T_2 - 4$$

\* round up to the next whole number

Example:

$$L = \left( \frac{2500 \text{ mm}}{60 \text{ mm}} \right) \cdot 60 \text{ mm} - 4 \text{ mm}$$

$$L = 42 \cdot 60 \text{ mm} - 4 \text{ mm}$$

$$L = 2516 \text{ mm}$$

### Notes on ordering examples

- If the preferred dimension  $T_{15}$  cannot be used:
  - Select an end space  $T_1$  between  $T_{15}$  and  $T_{1\min}$
  - Do not go below the minimum spacing  $T_{1\min}$ !
- $T_1$ ,  $T_{1\min}$ ,  $T_{15}$  are the same at either end of the rail.

$L = n_B \cdot T_2 - 4$ <p>or</p> $L = n_{T_2} \cdot T_2 + 2 \cdot T_{15}$	$L$ = rail length (mm) $T_2$ = hole spacing*) (mm) $T_{15}$ = preferred dimension*) (mm) $n_B$ = number of holes $n_{T_2}$ = number of spaces *) see tables for values
--	---

### Ordering example 1, up to $L_{\max}$ :

- Guide rail size 55/85 with cover strip
- Accuracy class P
- Calculated rail length 2516 mm ( $41 \cdot T_2$ , preferred dimension  $T_{15} = 28$  mm; number of holes  $n_B = 42$ )

### Ordering data:

Part number, length (mm)

$T_1 / n_{T_2} \cdot T_2 / T_1$  (mm)

**1875-562-61, 2516 mm**

**28 / 41 · 60 / 28 mm**

### Ordering example 2, length $> L_{\max}$ :

- Guide rail size 55/85 with cover strip
- Accuracy class P
- Calculated rail length 7556 mm, 2 sections ( $125 \cdot T_2$ , preferred dimension  $T_{15} = 28$  mm; number of holes  $n_B = 126$ )

### Ordering data:

Part number and number of sections, length (mm)

$T_1 / n_{T_2} \cdot T_2 / T_1$  (mm)

**1875-562-62, 7556 mm**

**28 / 125 · 60 / 28 mm**

Rail lengths greater than  $L_{\max}$  are made up of matching rail sections mounted end to end.

# Rexroth Roller Rail Systems

## Wide Guide Rails, Hard Chrome-Plated

### Guide rail 1873-

With double-row mounting hole pattern, for mounting from above, with cover strip of stainless spring steel

#### Hard chrome-plated

Part numbers / end face coating:

– 1873-...-7. (end faces coated)

#### Notes

The mounting holes and the tap holes at the end faces are chrome-plated.

Observe the mounting instructions!

Send for the publication "Mounting Instructions for the Cover Strip".

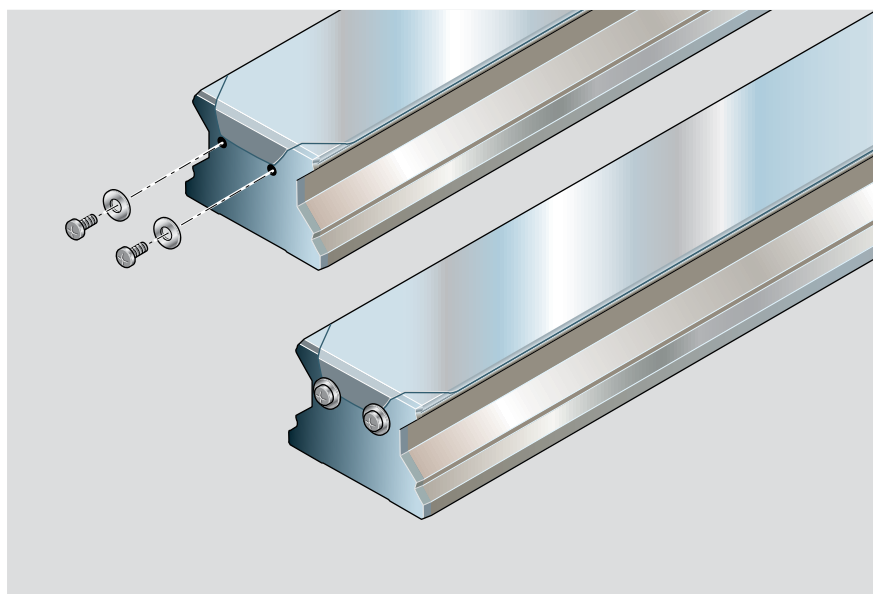

### Part numbers and rail lengths

Size	Accuracy class	Guide rail with cover strip one-piece <sup>1)</sup>
		Part number, Rail length L (mm)
55/85	H	1873-563-71, ....
65/100	H	1873-663-71, ....

<sup>1)</sup> Composite guide rails on request

### Recommended rail lengths

Size	Spacing $T_2$ (mm)	Recommended rail lengths
		Number of holes $n_B$ / rail length L (mm)
55/85	60	according to formula $L = n_B \cdot T_2 - 4$ up to 66/3956 max.
65/100	75	according to formula $L = n_B \cdot T_2 - 4$ up to 53/3971 max.

## Dimensions and weights

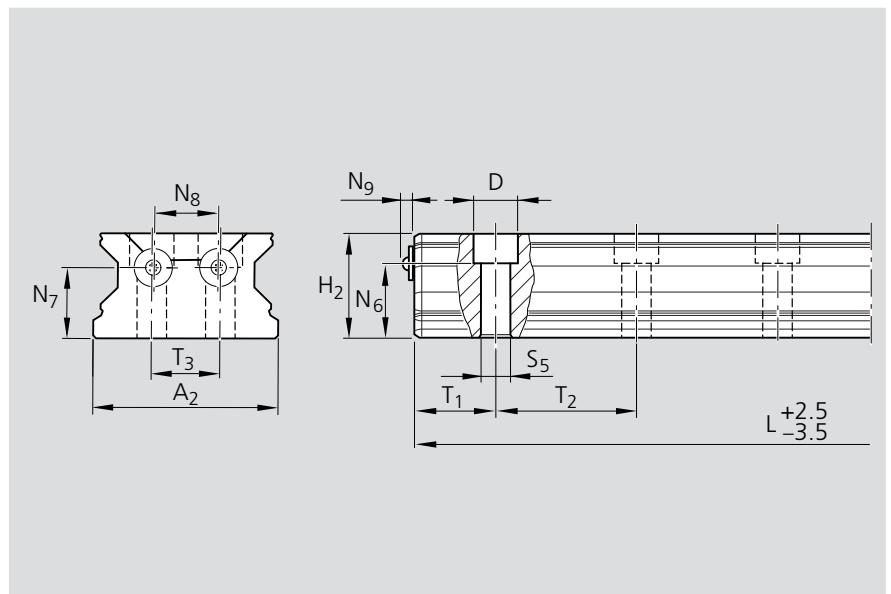

Size	Dimensions (mm)													Weight (kg/m)
	A <sub>2</sub>	H <sub>2</sub> <sup>1)</sup>	N <sub>6</sub> <sup>±0.5</sup>	N <sub>7</sub>	N <sub>8</sub>	N <sub>9</sub>	D	S <sub>5</sub>	T <sub>1</sub> <sup>±1.5</sup> <sup>2)</sup>	T <sub>1 min</sub> <sup>3)</sup>	T <sub>2</sub>	T <sub>3</sub>	L <sub>max</sub>	
<b>55/85</b>	85	47.85	31.2	30	32	4.8	20	14	28.0	18	60	32	4000	24.62
<b>65/100</b>	100	58.15	39	40	37	4.8	24	16	35.5	20	75	38	4000	34.68

1) Dimension H<sub>2</sub> with 0.3 mm cover strip

2) Preferred dimension

3) Rails with T<sub>1</sub> smaller than T<sub>1 min</sub> have no tap hole at the end face for securing the strip!

Secure the cover strip!

Observe mounting instructions!

The washer and screw are included in the supply scope.

# Rexroth Roller Rail Systems

## Product Overview – Heavy Duty Steel Runner Blocks

Rexroth Heavy Duty Roller Rail Systems were specially developed for use in heavy machine tools, plastics processing equipment, forming machines, etc., calling for compact, rolling-element linear motion guideways. They are available in various accuracy classes, each with extremely high load capacity and high rigidity.

### Make up your own compact linear motion guideways from interchangeable standard stock elements...

Rexroth fabricates its guide rails and runner blocks with such high precision that each individual component element can be replaced by another at any time. This makes infinite combinations possible. Each element can be individually ordered and separately stocked.

Both sides of the guide rail can be used as reference edges.

- Uniform guide rail profile with or without cover strip allows unrestricted interchangeability of components across all runner block variants.
- Lube ports on all sides for maximum ease of maintenance.
- Novel lube duct design minimizes lubricant consumption.
- Innovative cage design allows for longer lubrication intervals.
- Smooth running thanks to optimized roller recirculation and guidance.
- Mounting of attachments to runner block from above or below.
- Improved rigidity under lift-off and side loading conditions through three additional mounting screw holes at the center of the runner block.
- Optimized entry-section geometry and high number of rollers per track minimizes variation in elastic deflection.
- Aluminum end caps.

For heavy duty applications:

### Rexroth Heavy Duty Roller Rail Systems Standard width

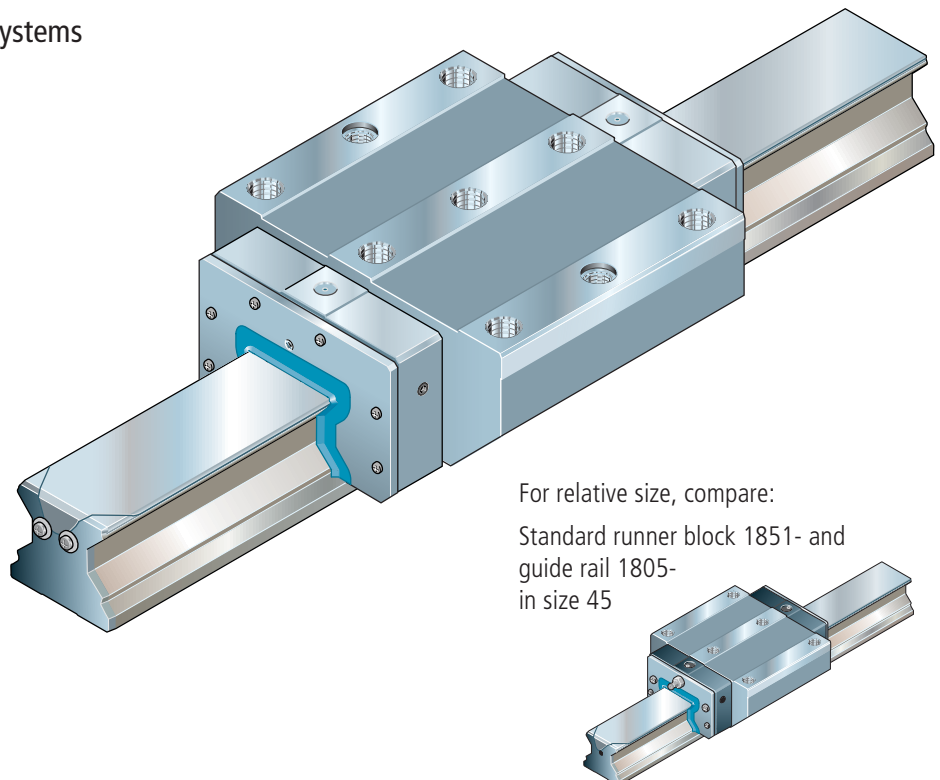

Rexroth Heavy Duty Roller Rail Systems  
Standard width, long

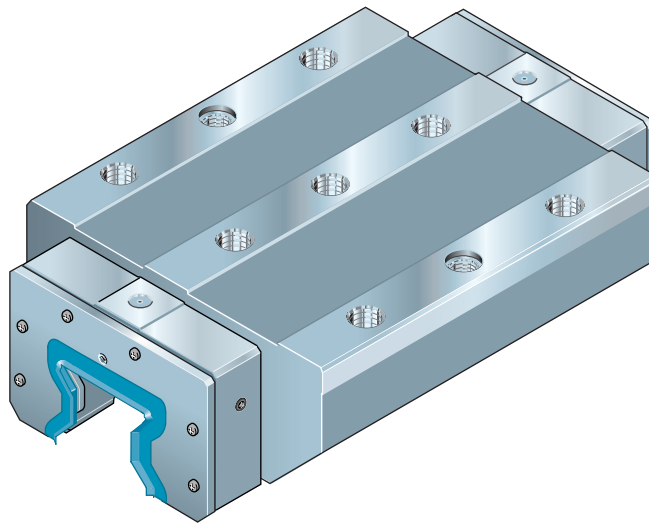

- Maximum rigidity under load from all directions
- High torque capacity
- Integrated all-round sealing
- End seal as standard
- Guide rails and runner blocks also available hard chrome-plated
- Aluminum end caps

Proven cover strip for guide rail mounting holes:

- A *single* cover for all holes
- Stainless spring steel to EN 10088
- Easy to fit – simply clip on and secure

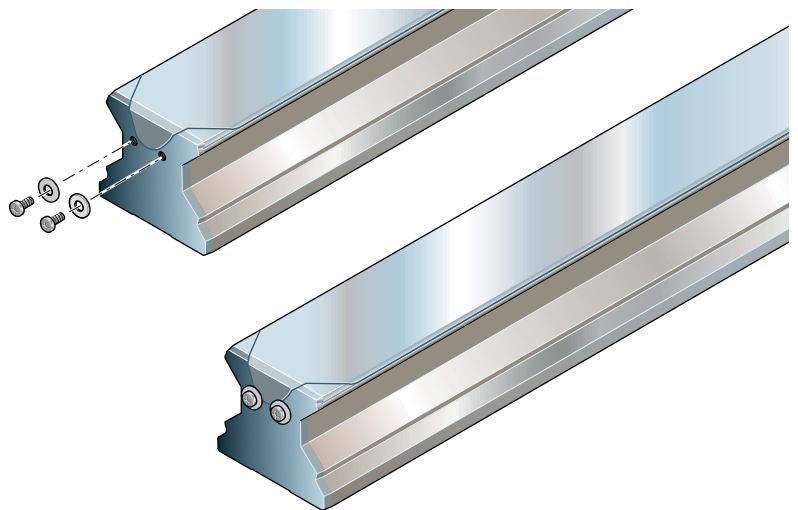

# Rexroth Roller Rail Systems

## Product Description – Heavy Duty Steel Runner Blocks

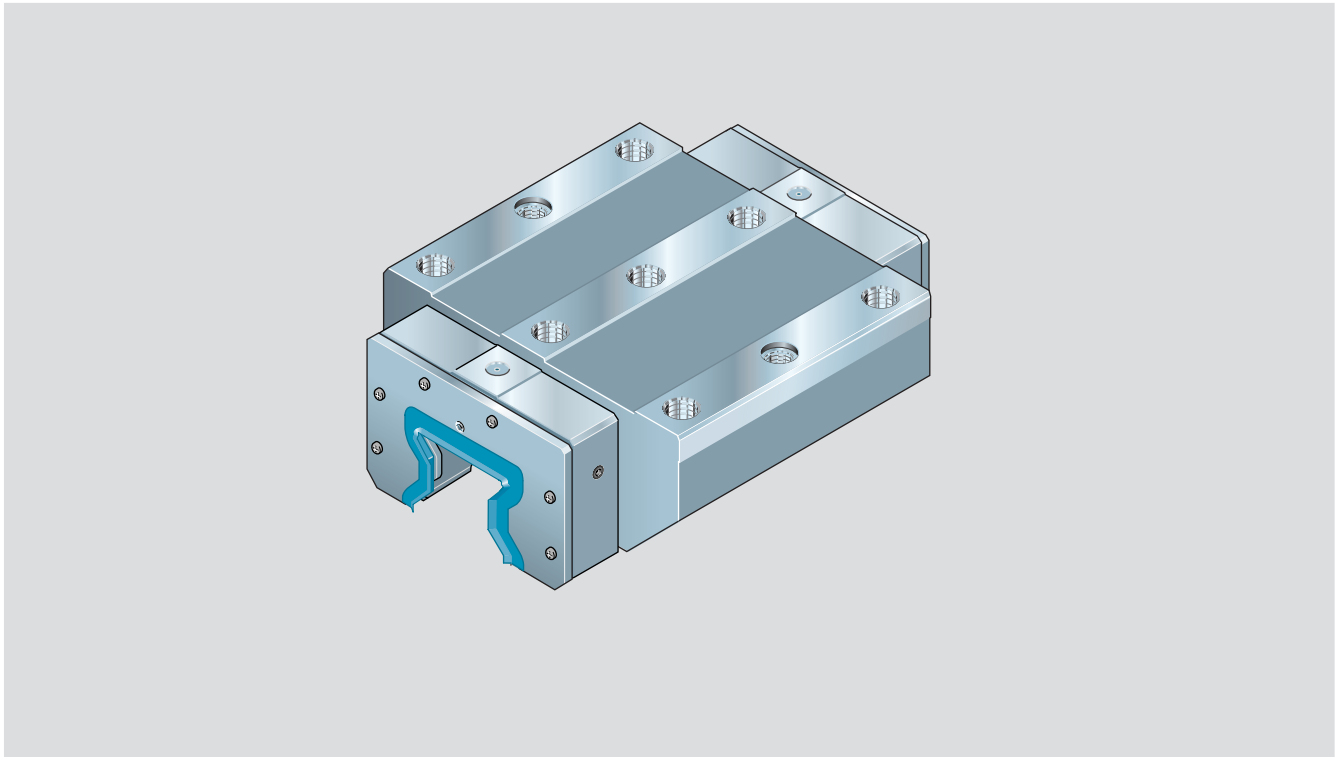

### The Roller Rail Systems consist of:

- guide rail, all surfaces ground, hardened bearing surfaces
- runner block of anti-friction bearing steel, hardened and ground raceways, with:
  - rollers made of anti-friction bearing steel
  - cage designed for optimum roller recirculation
  - fully sealed roller raceways
  - aluminum end caps
  - two end seals for better sealing and to protect plastic parts.

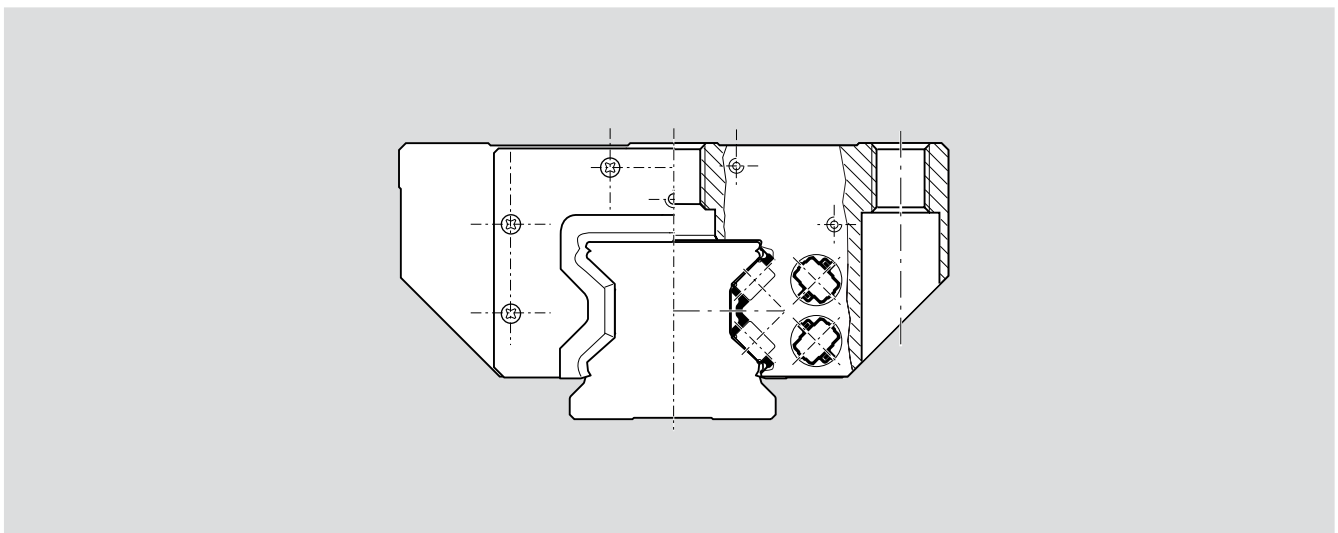



# Technical Data – Heavy Duty Steel Runner Blocks

## Accuracy classes and their tolerances (µm)

Rexroth Roller Rail Systems are available in up to 2 different accuracy classes.

For available versions see “Part number” tables.

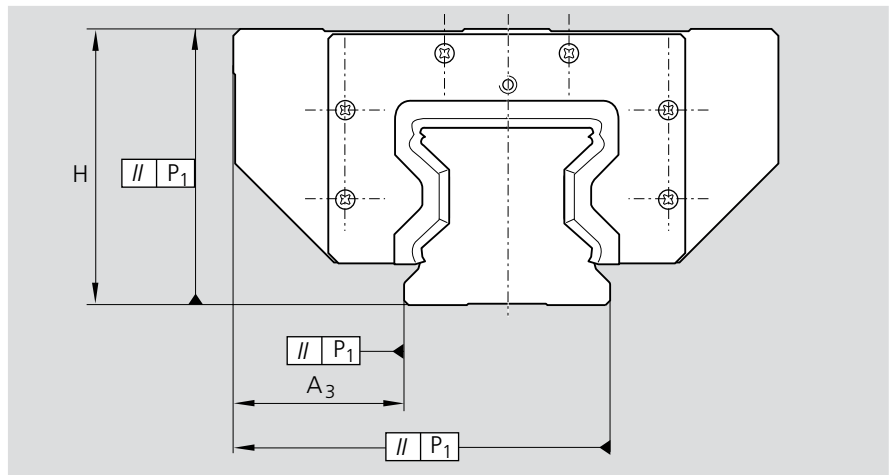

## Built-in interchangeability due to precision machining

Rexroth machines its guide rails and runner blocks, and the roller raceways in particular, with such high precision that each individual element is interchangeable.

Any runner block can be combined with any guide rail of the same size. It is also possible to install several different runner blocks on the same guide rail.

## Heavy duty steel runner blocks

Accuracy classes	Dimensional tolerances (µm)		Max. difference in dimensions H and A <sub>3</sub> on the same guide rail Δ H, Δ A <sub>3</sub> (µm)
	H	A <sub>3</sub>	
P	± 20	± 10	7
H	± 40	± 20	15

## Special versions: hard chrome-plated

	H		A <sub>3</sub>		Δ H, Δ A <sub>3</sub> (µm)	
	RB/GR	GR	RB/GR	GR	RB/GR	GR
P	+ 27 - 18	+ 24 - 19	± 13	+9 -14	10	7
H	+ 47 - 38	+ 44 - 39	± 23	+ 19 - 24	18	15

## Abbreviations

- RB/GR = runner block and guide rail hard chrome-plated
- GR = only the guide rail is hard chrome-plated

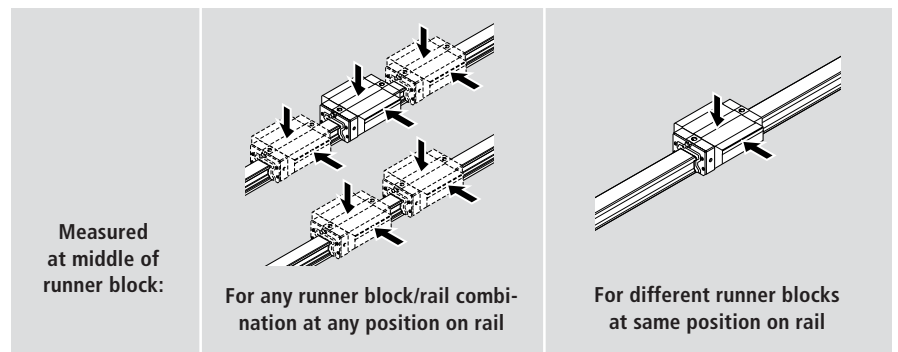

## Parallelism offset P<sub>1</sub> of Roller Rail Systems when properly installed

### Measured at middle of runner block

Values apply to roller rail systems without surface coating.

With hard chrome-plated guide rails, the values may increase by up to 2 µm.

## Legend

- P<sub>1</sub> = parallelism offset
- L = rail length

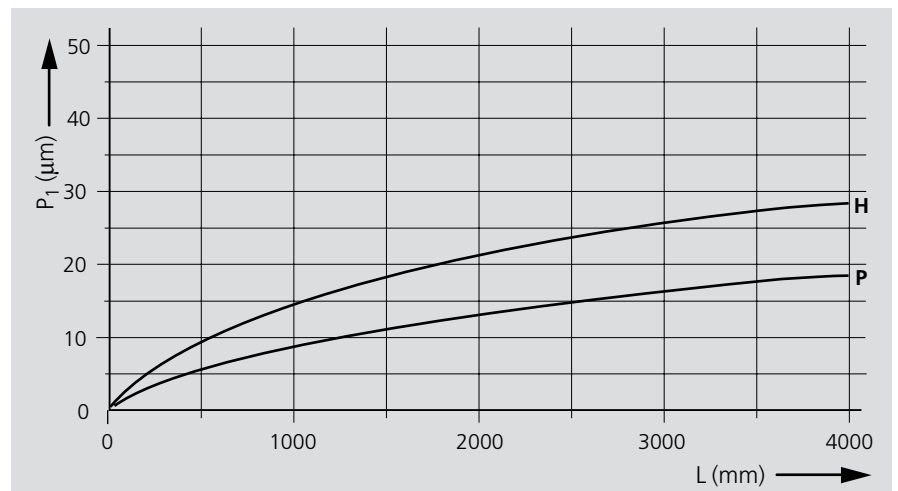

# Rexroth Roller Rail Systems

## Technical Data – Heavy Duty Steel Runner Blocks

### Rigidity of the Roller Rail System at 0.13 C preload

Runner block 1861-  
Standard width

————— measured values

Runner block mounted using  
9 screws:

- 6 outer screws of strength class 12.9
- 3 centerline screws of strength class 8.8

#### 1. Down load

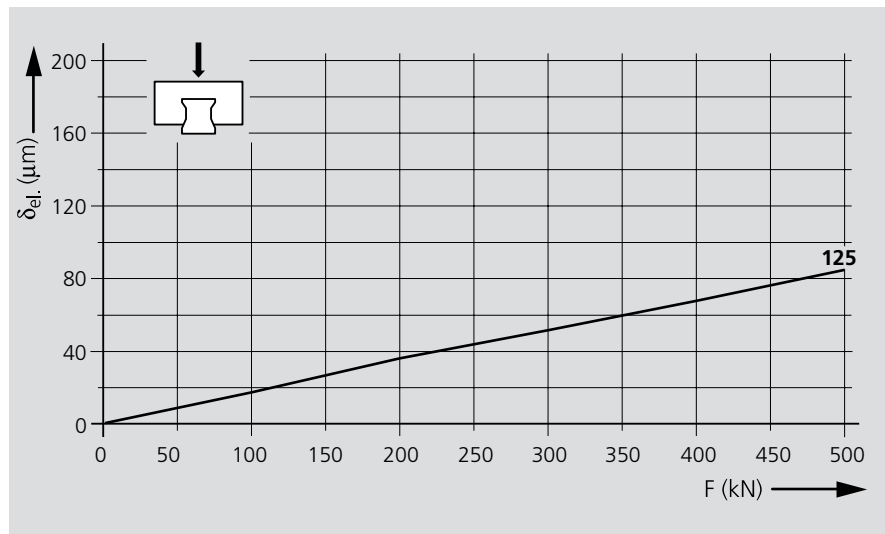

#### 2. Lift-off load

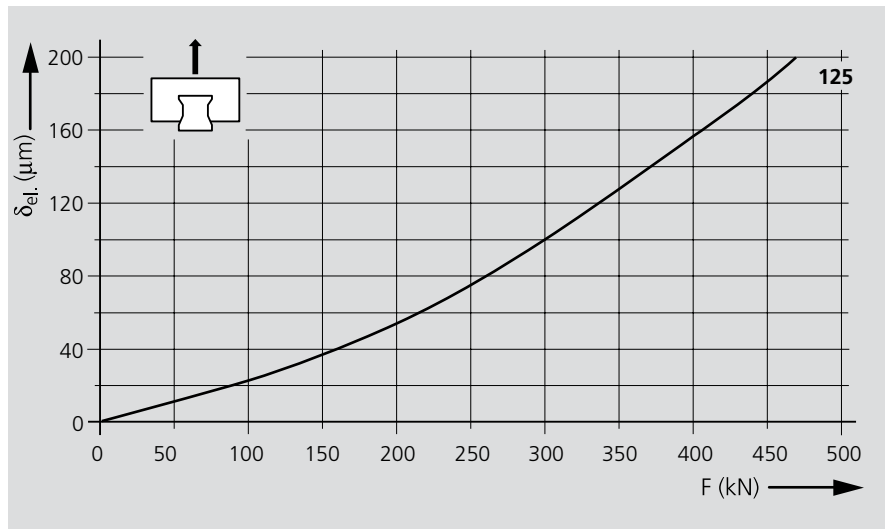

#### 3. Side load

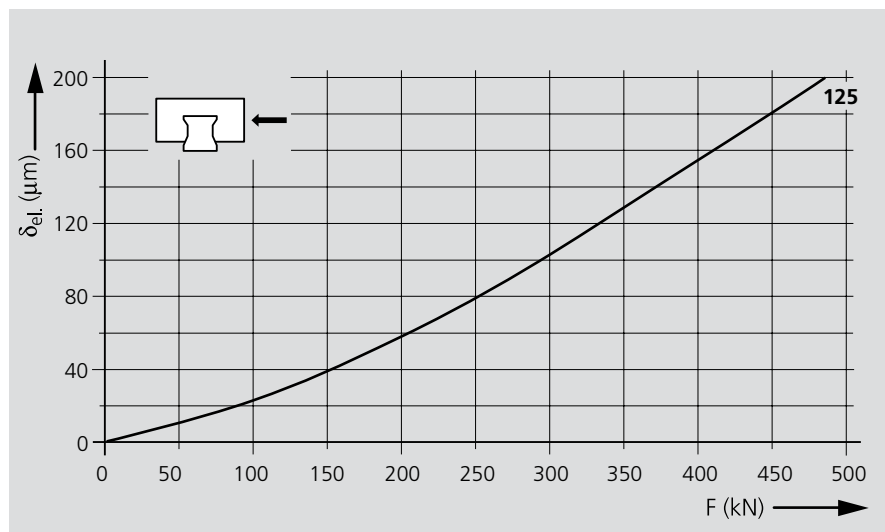

#### Legend

$\delta_{el.}$  = elastic deflection

F = load

# Technical Data – Heavy Duty Steel Runner Blocks

## Rigidity of the Roller Rail System at 0.13 C preload

Runner block 1863-  
Standard width

————— measured values

Runner block mounted using  
9 screws:

- 6 outer screws of strength class 12.9
- 3 centerline screws of strength class 8.8

### 1. Down load

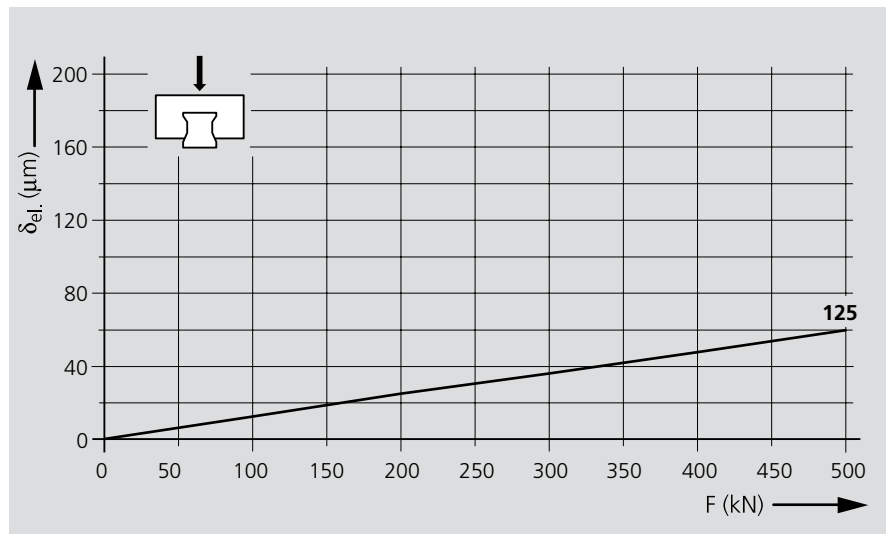

### 2. Lift-off load

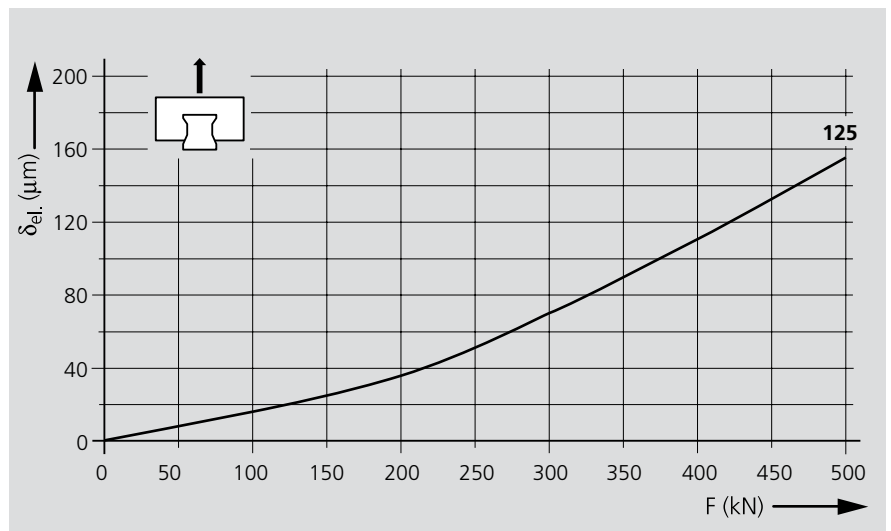

### 3. Side load

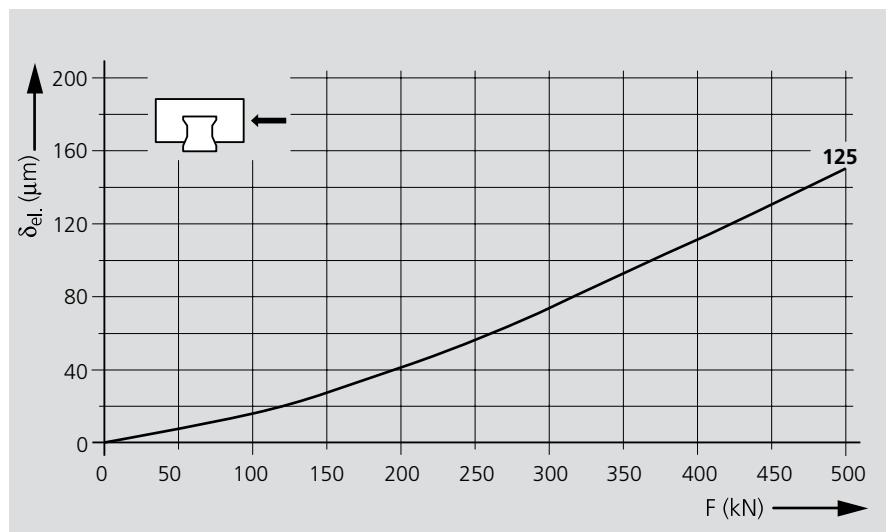

#### Legend

$\delta_{el.}$  = elastic deflection  
F = load

# Rexroth Roller Rail Systems

## Mounting Instructions for Heavy Duty Steel Runner Blocks

Reference edges, corner radii, screw sizes and tightening torques

**Runner block 186.- with guide rails 1835-, 1865-**

### Note

The recommended limits for permissible side loads **without additional lateral retention** indicate the approximate upper limits for screws in two strength classes. In other cases, the permissible side load must be calculated from the screw tension force. This can be up to about 15% less when using screws in strength class 10.9 instead of 12.9.

**⚠** Always check the strength factor of the screws in the case of high lift-off loads!

See "Load on the screw connections between the guide rail and the mounting base".

**Dimensions and recommended limits for permissible side loads if no additional lateral retention is provided**

- 1) For runner block mounting from above with only 6 O<sub>4</sub> screws:
  - Permissible side load 1/3 lower
  - Lower rigidity
- 2) For runner block mounting with 9 screws:
  - Tighten the centerline O<sub>2</sub> screws with the torque for strength class 8.8.
- 3) For mounting with 3 O<sub>2</sub> screws and 6 O<sub>1</sub> screws
- 4) Calculated with friction coefficient  $\mu = 0.12$

\* **Runner block 1861-**

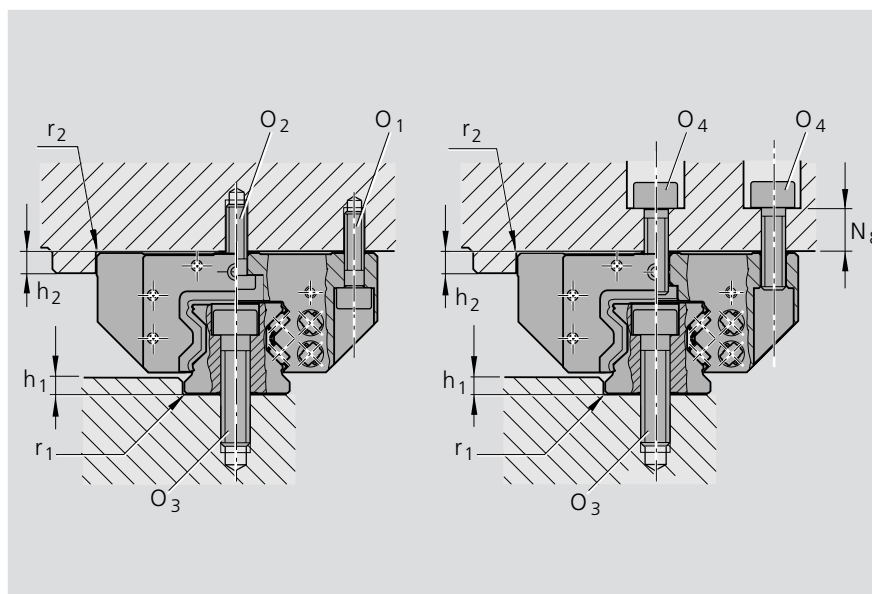

\*\***Runner block 1863-**

**Tightening torques for mounting screws**



Size	h <sub>1</sub>		r <sub>1</sub>	h <sub>2</sub>	r <sub>2</sub>	O <sub>1</sub>	O <sub>2</sub>	O <sub>4</sub> <sup>1)2)</sup>	O <sub>3</sub>	N <sub>8</sub>
	min. (mm)	max. (mm)	max. (mm)	(mm)	max. (mm)	DIN 912 6 screws	DIN 6912 3 screws	DIN 912 9 screws	DIN 912	(mm)
<b>125</b>	15	20	1.8	23	1.8	M24x85	M24x70	M27x80	M30x120	40

Screw strength class	Permissible side load if no lateral retention is provided <sup>4)</sup>					
	Runner block			Rail		
<b>8.8</b> *	0.09 C	0.13 C <sup>3)</sup>	0.20 C	0.10 C		
<b>12.9</b> *	0.15 C	0.19 C <sup>3)</sup>	0.30 C	0.17 C		
<b>8.8</b> **	0.07 C	0.11 C <sup>3)</sup>	0.16 C	0.07 C		
<b>12.9</b> **	0.12 C	0.16 C <sup>3)</sup>	0.23 C	0.12 C		

	M24	M27	M30
			
<b>8.8</b>	660	980	1350
 <b>Nm</b>	<b>10.9</b>	930	1400
	<b>12.9</b>	1100	1650
		1650	2250

### Mounting the runner block

Before sliding on the runner block, mount the cover strip on the guide rail and oil or grease the runner block seal and the bevels at the rail end!

Sliding the runner block onto the rail is easier with the aid of a mounting handle, which is available on request (see "Accessories").

## Instructions for mounting composite guide rails

### Rails made up of two sections

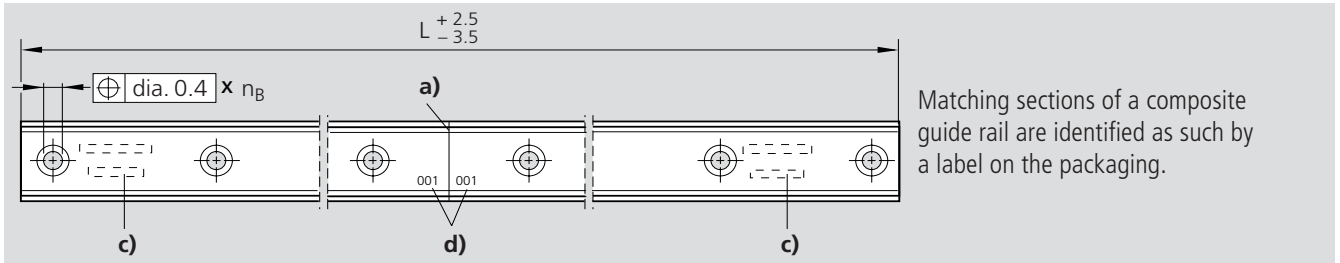

### Rails made up of three or more sections

All sections of the same rail have the same number, which is marked on the top of the guide rail.

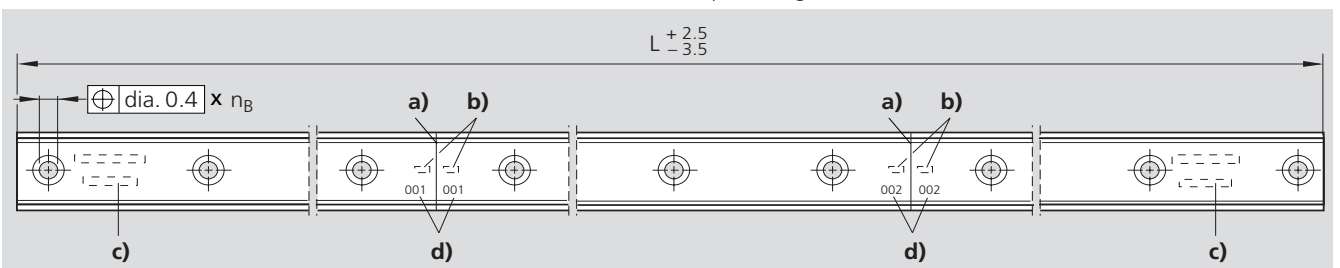

$n_B$  = number of holes

- a) Joint
- b) Rail number
- c) Full rail identification on first and last sections
- d) Joint number

#### Note on cover strip

For composite rails, a cover strip to cover the total length L is supplied separately along with the rails.

### New: Adjusting shaft

The sections of composite rails can be aligned with the aid of an adjusting shaft. For more detailed information see "Accessories" and Mounting Instructions for Roller Rail Systems.

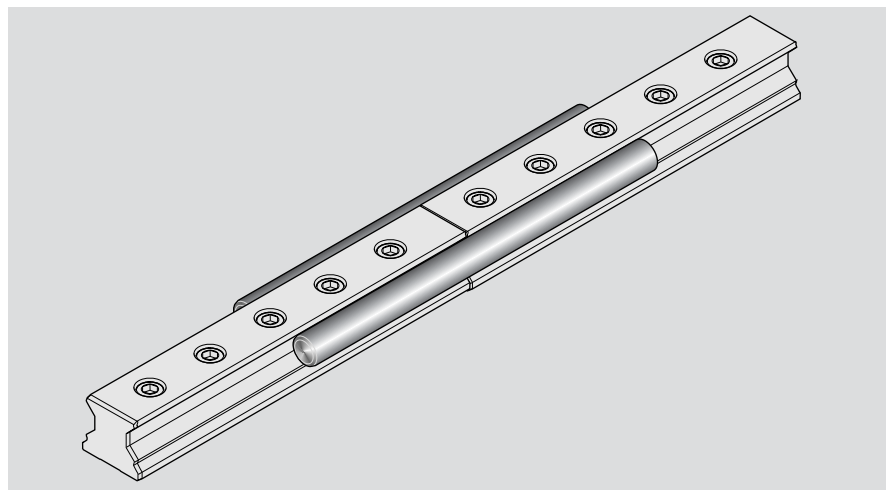

# Rexroth Roller Rail Systems

## Heavy Duty Steel Runner Blocks

### Heavy duty runner block 1861-

#### Standard width

#### Notes

For short-stroke applications (stroke < 2 runner block lengths), use additional lube ports (B<sub>4</sub>, N<sub>7</sub>).

All lube ports:

M8x1 tap holes in the metal.

Friction force:

≈ 1000 N when freshly lubricated

≈ 600 N after the run-in phase

#### Mounting instructions

Before sliding on the runner block, mount the cover strip on the guide rail and oil or grease the runner block seal and the bevels at the rail end!

Sliding the runner block onto the rail is easier with the aid of a mounting handle (part number 1869-340-09, see "Accessories").

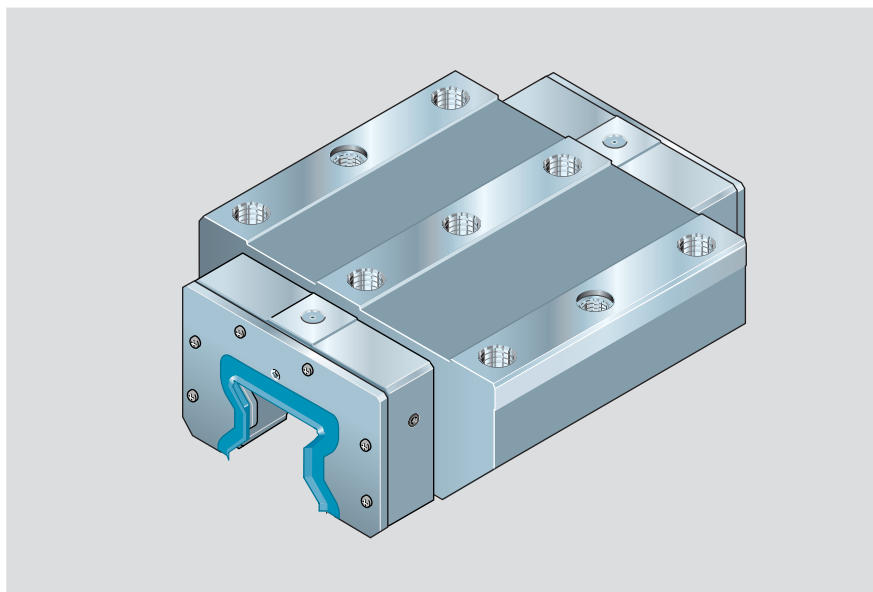

#### Special version

- hard chrome-plated,  
Part number 1861-...-60

Note: For tolerances other than those specified here for dimensions H and A<sub>3</sub>, see the table of accuracy classes and their tolerances in the "Technical Data" section.

Combining a hard chrome-plated runner block with a hard chrome-plated guide rail results in a preload of approx. 0.15 C.

#### Part numbers

Size	Accuracy class	Part numbers
		Preload 0.13 C
125	P	1861-332-10
	H	1861-333-10

#### Load capacities and moments

#### Note on dynamic load capacities and moments

The dynamic load capacities and moments are based on 100,000 m travel.

However, a travel of just 50,000 m is often taken as a basis. If this is the case, for comparison purposes:

Multiply values **C**, **M<sub>t</sub>** and **M<sub>L</sub>** from the Rexroth table by 1.23.

Size	Load capacities (N)		Moments (Nm)			
	C <sub>dyn.</sub>	C <sub>0 stat.</sub>	M <sub>t dyn.</sub>	M <sub>t0 stat.</sub>	M <sub>L dyn.</sub>	M <sub>L0 stat.</sub>
125	603000	1324000	43420	95330	23620	51860

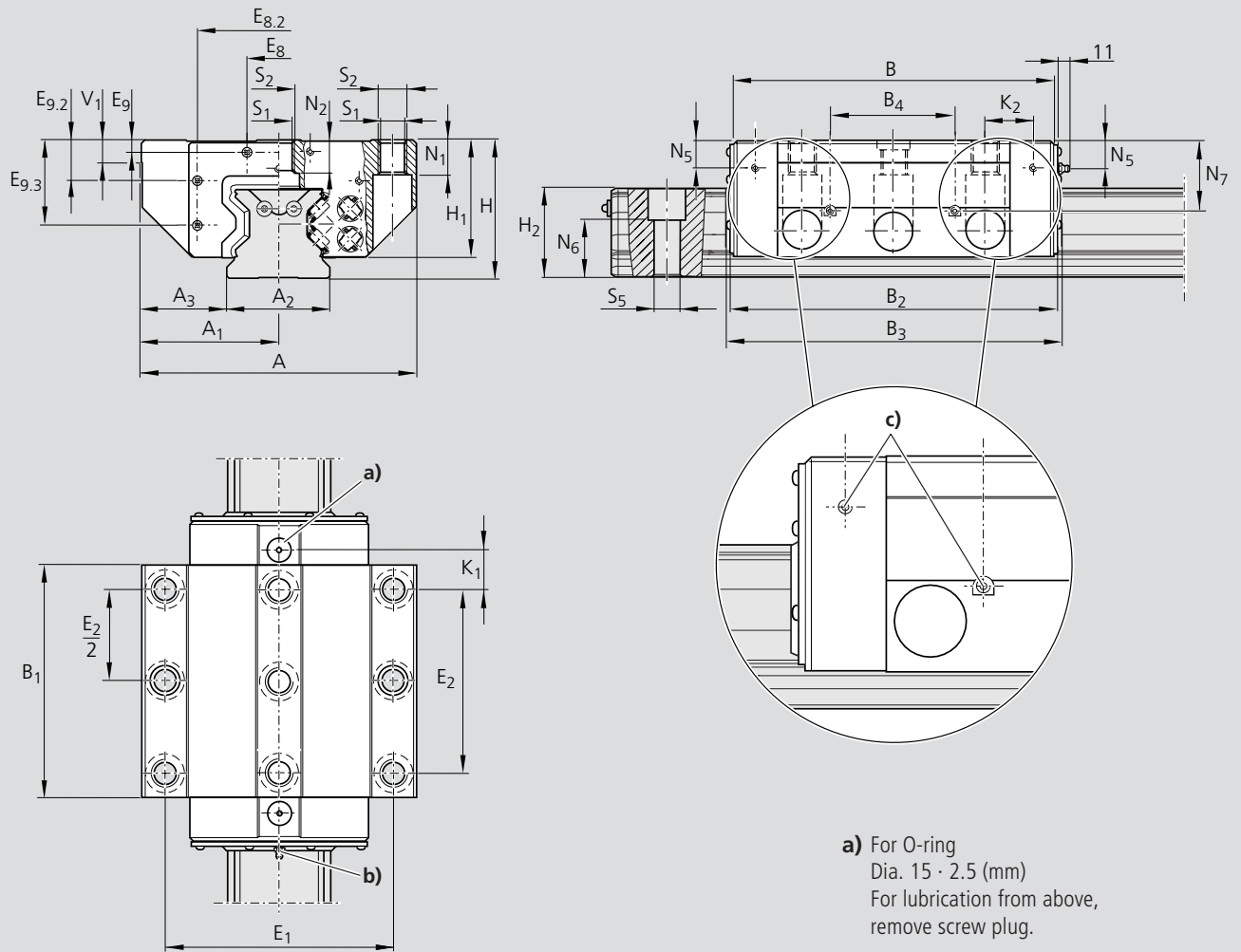

- a)** For O-ring  
Dia. 15 · 2.5 (mm)  
For lubrication from above,  
remove screw plug.
- b)** Lube nipple, thread M8x1:  
can be fitted on all sides.  
All lube ports are in metal.
- c)** Side lube ports on both sides.

Dimensions (mm)																
Size	A	A <sub>1</sub>	A <sub>2</sub>	A <sub>3</sub>	B	B <sub>1</sub>	B <sub>2</sub>	B <sub>3</sub>	B <sub>4</sub>	H	H <sub>1</sub>	H <sub>2</sub> <sup>1)</sup>	V <sub>1</sub>	E <sub>1</sub>	E <sub>2</sub>	
125	320	160	125	97.5	371	255	377	386.5	130	160	135	115.3	25	270	205	

Dimensions (mm)																Weight
Size	E <sub>8</sub>	E <sub>8.2</sub>	E <sub>9</sub>	E <sub>9.2</sub>	E <sub>9.3</sub>	N <sub>1</sub>	N <sub>2</sub>	N <sub>5</sub>	N <sub>6</sub> <sup>±0.5</sup>	N <sub>7</sub>	S <sub>1</sub>	S <sub>2</sub>	S <sub>5</sub>	K <sub>1</sub>	K <sub>2</sub>	(kg)
125	80	205	12	40	92	45	29	29	74.5	92	25	M27	33	50.0	50.0	62.1

<sup>1)</sup> Dimension H<sub>2</sub> with cover strip

# Rexroth Roller Rail Systems

## Heavy Duty Steel Runner Blocks

### Heavy duty runner block 1863-

#### Standard width, long

#### Notes

For short-stroke applications (stroke < 2 runner block lengths), use additional lube ports (B<sub>4</sub>, N<sub>7</sub>).

All lube ports:

M8x1 tap holes in the metal.

Friction force:

≈ 1000 N when freshly lubricated

≈ 600 N after the run-in phase

#### Mounting instructions

Before sliding on the runner block, mount the cover strip on the guide rail and oil or grease the runner block seal and the bevels at the rail end!

Sliding the runner block onto the rail is easier with the aid of a mounting handle (part number 1869-340-09, see "Accessories").

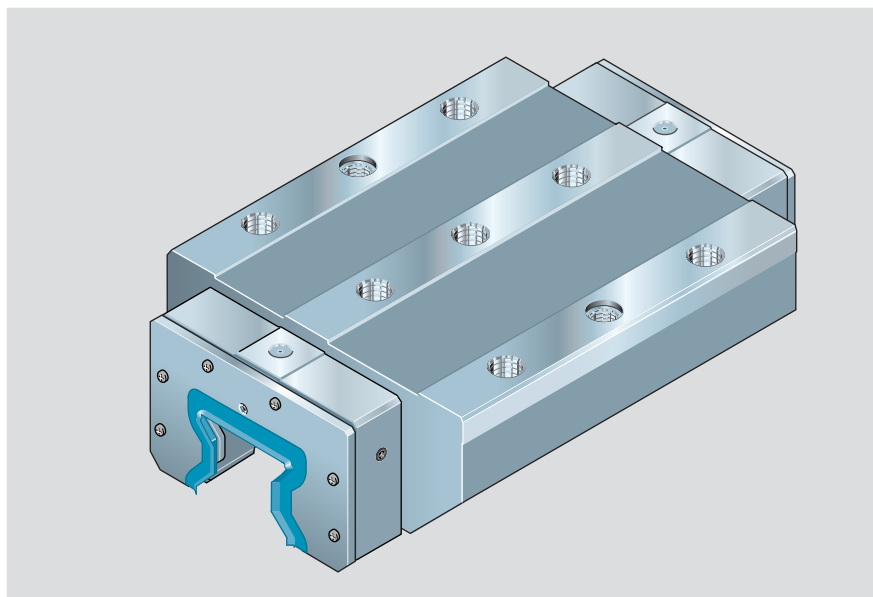

#### Special version

– hard chrome-plated,

Part number 1863-...-60

Combining a hard chrome-plated runner block with a hard chrome-plated guide rail results in a preload of approx. 0.15 C.

#### Part numbers

Size	Accuracy class	Part numbers
		Preload 0.13 C
125	P	1863-332-10
	H	1863-333-10

#### Load capacities and moments

#### Note on dynamic load capacities and moments

The dynamic load capacities and moments are based on 100,000 m travel.

However, a travel of just 50,000 m is often taken as a basis. If this is the case, for comparison purposes:

Multiply values **C**, **M<sub>t</sub>** and **M<sub>L</sub>** from the Rexroth table by 1.23.

Size	Load capacities (N)		Moments (Nm)			
	C dyn.	C <sub>0</sub> stat.	M <sub>t</sub> dyn.	M <sub>t0</sub> stat.	M <sub>L</sub> dyn.	M <sub>L0</sub> stat.
125	802000	1941900	57740	139820	45080	109150



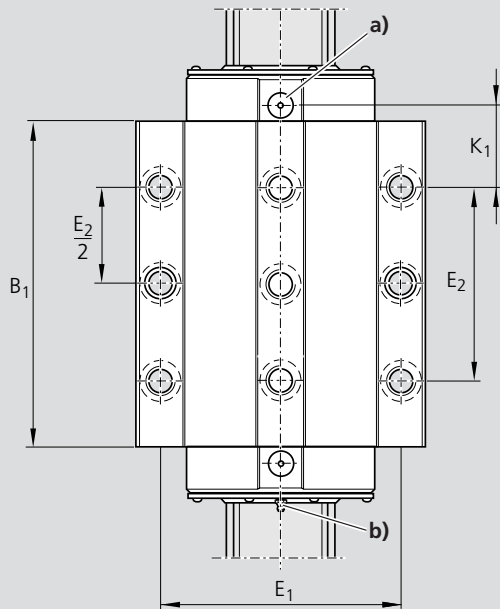
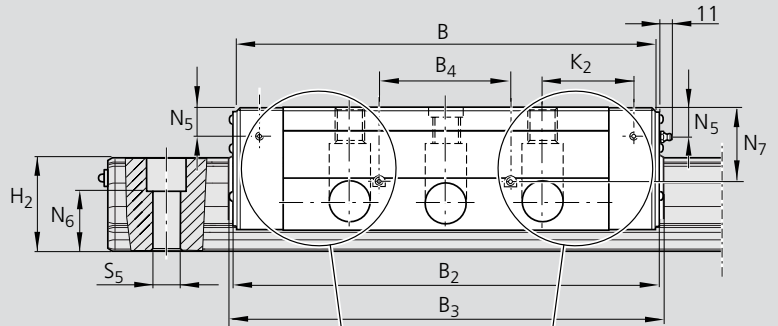
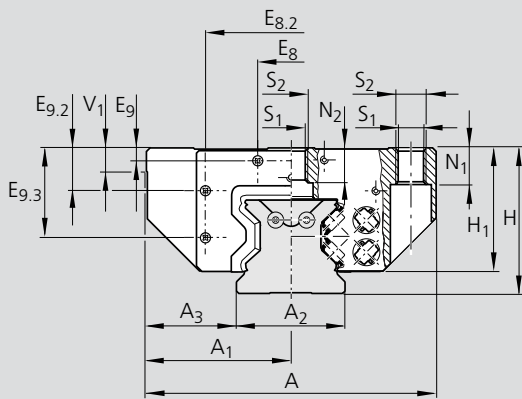

- a)** For O-ring  
Dia. 15 · 2.5 (mm)  
For lubrication from above,  
remove screw plug.
- b)** Lube nipple, thread M8x1:  
can be fitted on all sides.  
All lube ports are in metal.
- c)** Side lube ports on both sides.

Dimensions (mm)

Size	A	A <sub>1</sub>	A <sub>2</sub>	A <sub>3</sub>	B	B <sub>1</sub>	B <sub>2</sub>	B <sub>3</sub>	B <sub>4</sub>	H	H <sub>1</sub>	H <sub>2</sub> <sup>1)</sup>	V <sub>1</sub>	E <sub>1</sub>	E <sub>2</sub>
125	320	160	125	97.5	476	360	482	491.5	150	160	135	115.3	25	270	205

Dimensions (mm)

Size	E <sub>8</sub>	E <sub>8.2</sub>	E <sub>9</sub>	E <sub>9.2</sub>	E <sub>9.3</sub>	N <sub>1</sub>	N <sub>2</sub>	N <sub>5</sub>	N <sub>6</sub> <sup>±0.5</sup>	N <sub>7</sub>	S <sub>1</sub>	S <sub>2</sub>	S <sub>5</sub>	K <sub>1</sub>	K <sub>2</sub>	Weight (kg)
125	80	205	12	40	92	45	29	29	74.5	92	25	M27	33	102.5	102.5	89.8

<sup>1)</sup> Dimension H<sub>2</sub> with cover strip

# Rexroth Roller Rail Systems

## Heavy Duty Guide Rails

### Guide rail 1835-

**For mounting from above,  
heavy duty rail with cover strip  
of stainless spring steel**

Special version:

– hard chrome-plated

The part numbers for this version are given on separate pages at the end of this section.

The cover strip, screws and washers are included in the supply scope; they are supplied along with the rails but in a separate packing unit.

Observe the mounting instructions!

Send for the publication "Mounting Instructions for the Cover Strip".

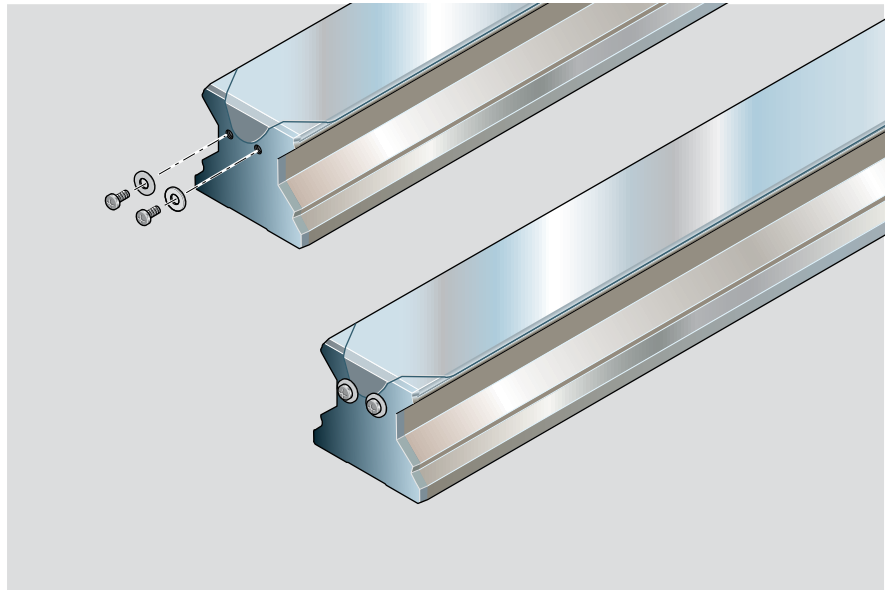

### Part numbers and rail lengths

Size	Accuracy class	Guide rail with cover strip	
		one-piece Part number, Rail length L (mm)	composite Part number, Number of sections, Rail length L (mm)
125	P	1835-362-61, ....	1835-362-6., ....
	H	1835-363-61, ....	1835-363-6., ....

### Recommended rail lengths

Size	Spacing $T_2$ (mm)	Recommended rail lengths Number of holes $n_B$ / rail length L (mm)
125	120	according to formula $L = n_B \cdot T_2 - 7$ up to 22/2634 max.

## Dimensions and weights

- 1) Dimension  $H_2$  with 0.3 mm cover strip
- 2) Rails with  $T_1$  smaller than  $T_{1\min}$  have no tap hole at the end face for securing the strip!  
Secure the cover strip!  
Observe mounting instructions!  
The washer and screw are included in the supply scope.

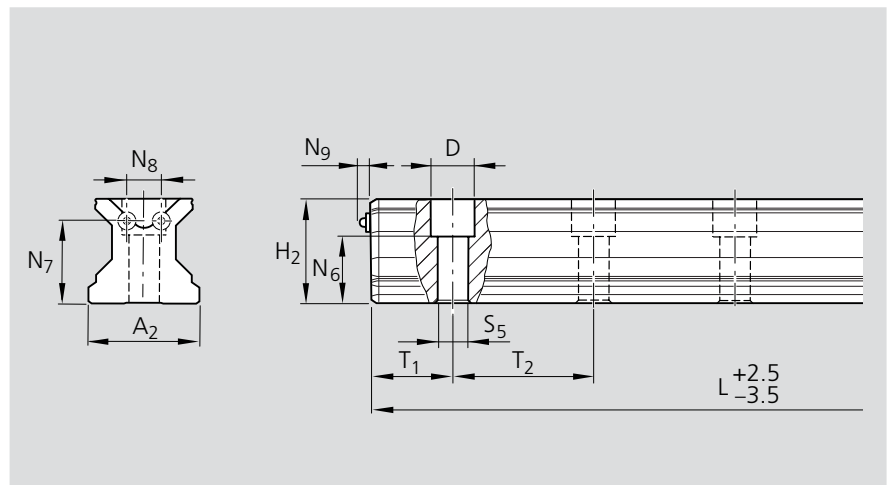

Size	Dimensions (mm)												Weight kg/m
	$A_2$	$H_2^{1)}$	$N_6^{\pm 0.5}$	$N_7$	$N_8$	$N_9$	$D$	$S_5$	$T_{15}^{+1.0/-1.5}$	$T_{1\min}$	$T_2$	$L_{\max}$	
125	125	115.3	74.5	91	38	4.8	49	33	56.5	40	120	2634	75.6

## Ordering guide rails in recommended lengths

The following examples apply to all guide rail orders. Recommended rails lengths are delivered with priority.

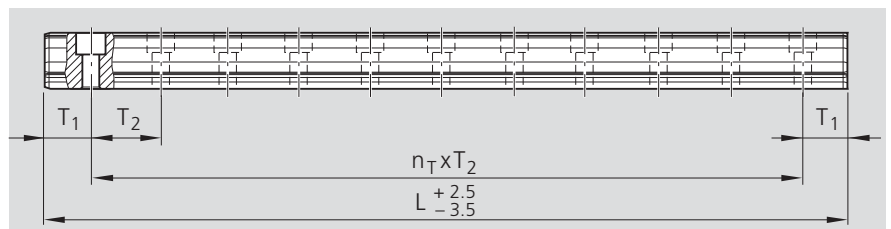

### From the desired length to the recommended length

$$L = \left( \frac{\text{desired length } L}{\text{hole spacing } T_2} \right)^* \cdot T_2 - 7$$

\* round up to the next whole number

Example:

$$L = \left( \frac{1650 \text{ mm}}{120 \text{ mm}} \right) \cdot 120 \text{ mm} - 7 \text{ mm}$$

$$L = 14 \cdot 120 \text{ mm} - 7 \text{ mm}$$

$$L = 1673 \text{ mm}$$

### Notes on ordering examples

- If the preferred dimension  $T_{15}$  cannot be used:
  - Select an end space  $T_1$  between  $T_{15}$  and  $T_{1\min}$
  - Do not go below the minimum spacing  $T_{1\min}$ !
- $T_1$ ,  $T_{1\min}$ ,  $T_{15}$  are the same at either end of the rail.

$L = n_B \cdot T_2 - 7$ <p>or</p> $L = n_{T_2} \cdot T_2 + 2 \cdot T_{15}$	$L$ = rail length (mm) $T_2$ = hole spacing*) (mm) $T_{15}$ = preferred dimension*) (mm) $n_B$ = number of holes $n_{T_2}$ = number of spaces *) see tables for values
--	---

### Ordering example 1, up to $L_{\max}$ :

- Guide rail size 125 with cover strip
- Accuracy class P
- Calculated rail length 1673 mm ( $13 \cdot T_2$ , preferred dimension  $T_{15} = 56.5$  mm; number of holes  $n_B = 14$ )

### Ordering data:

Part number, length (mm)

$T_1 / n_{T_2} \cdot T_2 / T_1$  (mm)

**1835-362-61, 1673 mm**

**56.5 / 13 · 120 / 56.5 mm**

### Ordering example 2, length $> L_{\max}$ :

- Guide rail size 125 with cover strip
- Accuracy class P
- Calculated rail length 5033 mm, 2 sections ( $41 \cdot T_2$ , preferred dimension  $T_{15} = 56.5$  mm; number of holes  $n_B = 42$ )

### Ordering data:

Part number and number of sections, length (mm)

$T_1 / n_{T_2} \cdot T_2 / T_1$  (mm)

**1835-362-62, 5033 mm**

**56.5 / 41 · 120 / 56.5 mm**

Rail lengths greater than  $L_{\max}$  are made up of matching rail sections mounted end to end.

# Rexroth Roller Rail Systems

## Heavy Duty Guide Rails, Hard Chrome-Plated

### Guide rail 1865-

For mounting from above,  
heavy duty rail with cover strip  
in stainless spring steel

Hard chrome-plated

#### Notes

For dimensions see guide rail 1835-

Hard chrome-plated one-piece guide rails are available in lengths of up to  $L_{\max} = 2634$  mm.

Part numbers / end face coating:

- 1865-...-71 (end faces coated, all composite guide rails are supplied with coated end faces)

The mounting holes and the tap holes at the end faces are chrome-plated.

The cover strip, screws and washers are included in the supply scope; they are supplied along with the rails but in a separate packing unit.

Observe the mounting instructions!

Send for the publication "Mounting Instructions for the Cover Strip".

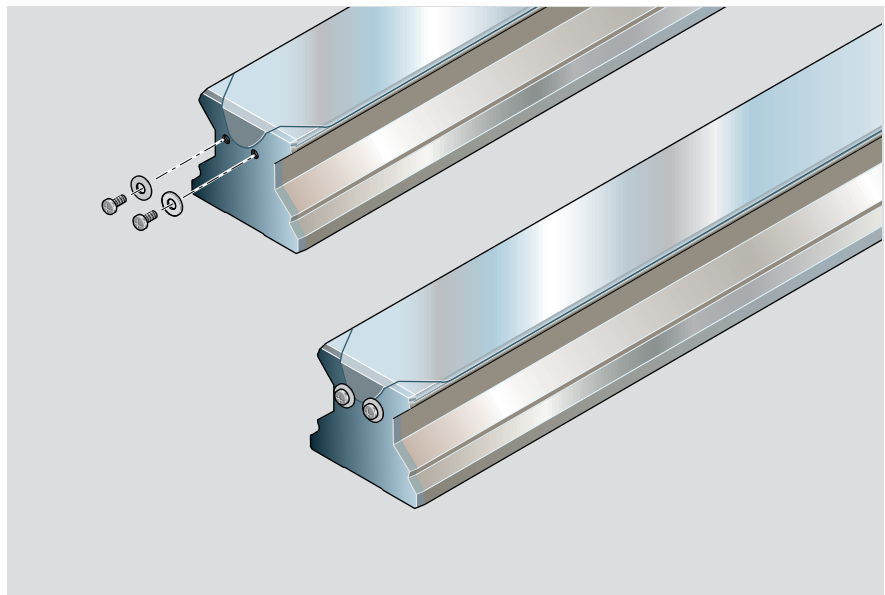

### Part numbers and rail lengths

Size	Accuracy class	Guide rail with cover strip one-piece <sup>1)</sup>
		Part number, Rail length L (mm)
125	P	1865-362-71, ....
	H	1865-363-71, ....

<sup>1)</sup> Composite guide rails on request

### Recommended rail lengths

Size	Spacing $T_2$ (mm)	Recommended rail lengths Number of holes $n_B$ / rail length L (mm)
125	120	according to formula $L = n_B \cdot T_2 - 7$ up to 22/2634 max.



# Rexroth Roller Rail Systems

## Product Overview – Accessories and Combination Options

Rexroth offers a broad array of accessories to cover almost all conceivable application requirements.

The complete range from a single source. Optimally matched for maximum efficiency.

### Accessories for standard runner blocks

#### Metal scrapers with spacer plate

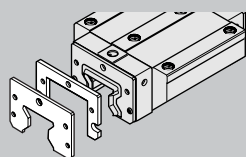

#### Viton/NBR wiper seals one- and two-piece versions

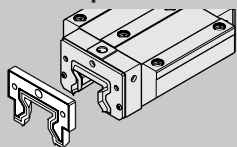

#### Lube plate

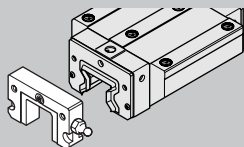

#### Lube adaptors (only for high runner blocks 1821-/1824-)

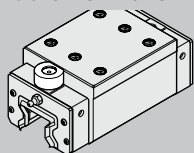

#### Front lube unit

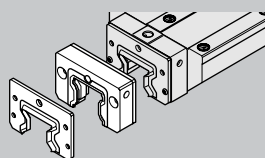

#### Bellows

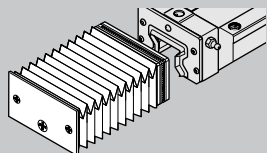

### Standard runner blocks

<b>Runner block</b>	<b>1851-...-10</b>
standard width	
with aluminum end caps	<b>1851-...-13</b>
hard chrome-plated	<b>1851-...-60</b>

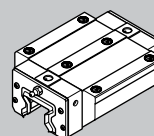

<b>Runner block</b>	<b>1853-...-10</b>
standard width, long	
with aluminum end caps	<b>1853-...-13</b>
hard chrome-plated	<b>1853-...-60</b>

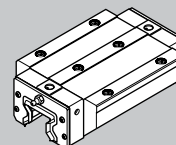

<b>Runner block</b>	<b>1821-...-10</b>
slimline, high	
with aluminum end caps	<b>1821-...-13</b>
hard chrome-plated	<b>1821-...-60</b>

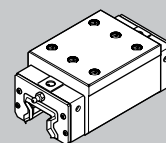

<b>Runner block</b>	<b>1824-...-10</b>
slimline, high, long	
with aluminum end caps	<b>1824-...-13</b>
hard chrome-plated	<b>1824-...-60</b>

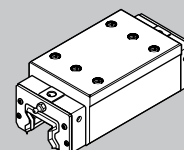

suitable for

# Product Overview – Accessories

## Accessories for standard guide rails

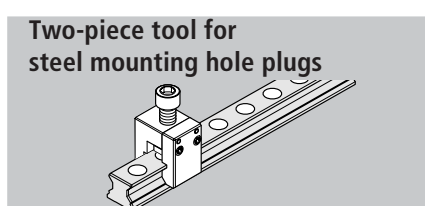
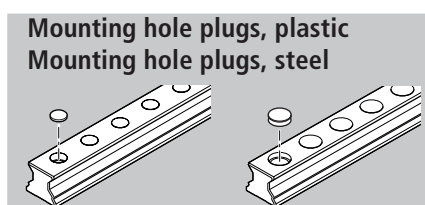
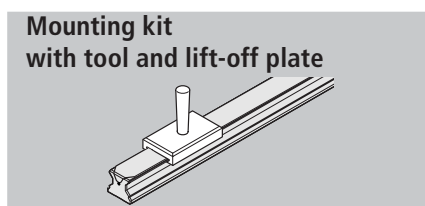
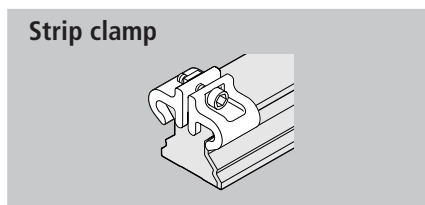
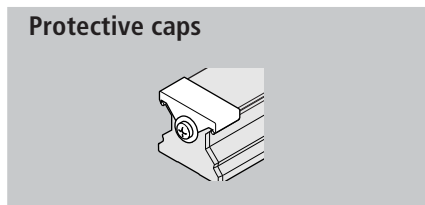
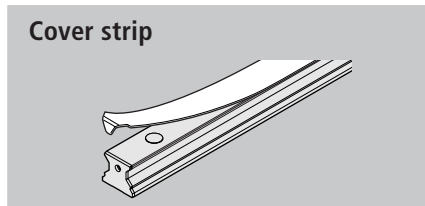

## Accessories for wide guide rails and heavy duty guide rails

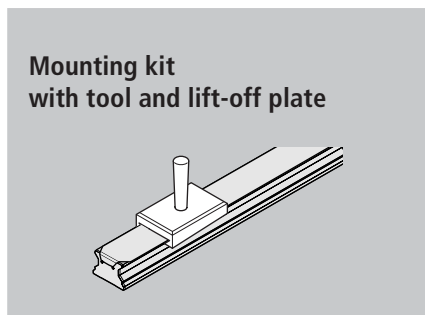

**suitable for**

## Standard guide rails

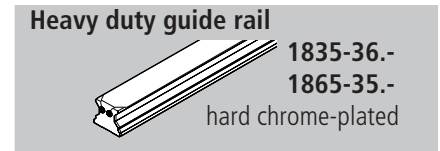
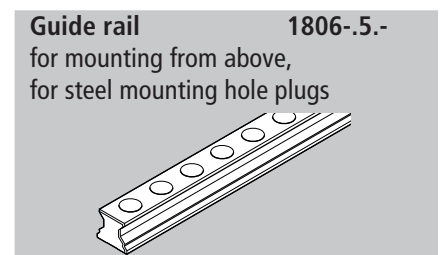
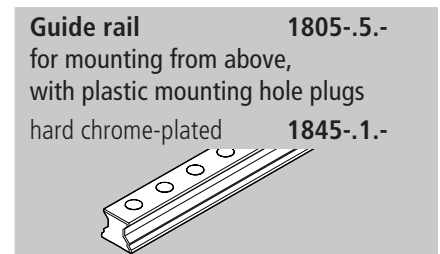
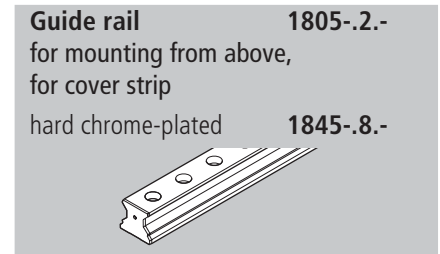
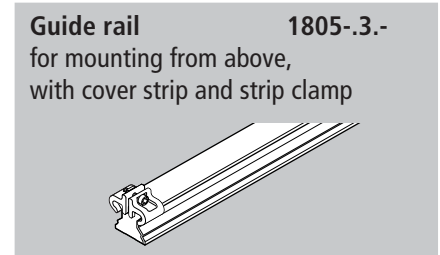
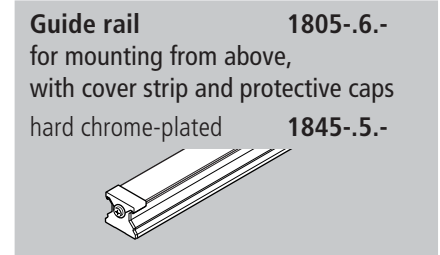

**suitable for**

# Rexroth Roller Rail Systems

## Product Overview – Accessories and Combination Options

### General accessories for runner blocks

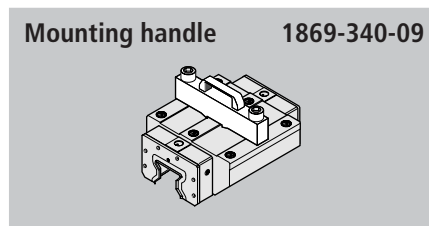
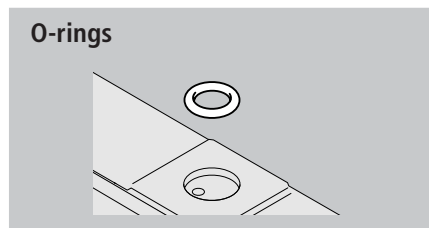
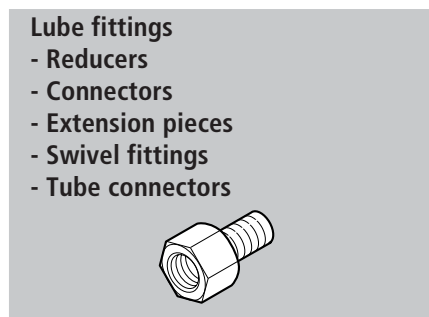
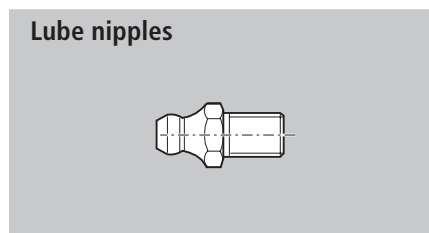

With the corresponding dimensions, suitable for

### Standard runner blocks

**Runner block** 1851-...-10  
 standard width  
 for wall mounting 1851-...-18  
 with aluminum end caps 1851-...-13  
 hard chrome-plated 1851-...-60

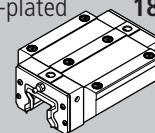

**Runner block** 1853-...-10  
 standard width, long  
 for wall mounting 1853-...-18  
 with aluminum end caps 1853-...-13  
 hard chrome-plated 1853-...-60

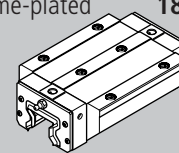

**Runner block** 1821-...-10  
 slimline, high  
 for wall mounting 1821-...-18  
 with aluminum end caps 1821-...-13  
 hard chrome-plated 1821-...-60

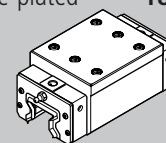

**Runner block** 1824-...-10  
 slimline, high, long  
 for wall mounting 1824-...-18  
 with aluminum end caps 1824-...-13  
 hard chrome-plated 1824-...-60

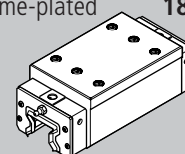

### Wide runner blocks

**Runner block** 1872-...-10  
 wide

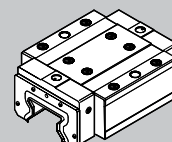

### Heavy duty runner blocks

**Runner block** 1861-/1863-  
 heavy duty

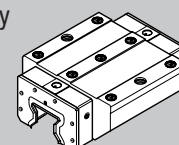



## Product Overview – Accessories

### General accessories for guide rails

Adjusting shafts

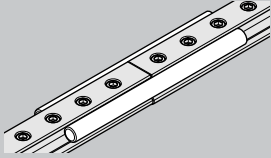

Expanding tool

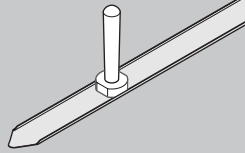

Wedge profile

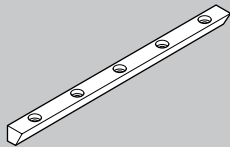

Mounting runner block

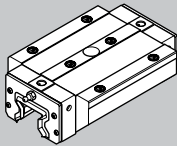

## Product Overview – Spare Parts

End seal

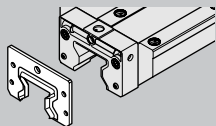

Transport and mounting arbor

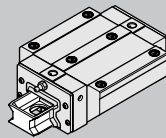

End cap with end seal

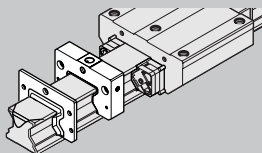

Aluminum end cap with end seal

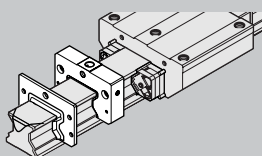

# Rexroth Roller Rail Systems

## Accessories for Standard Runner Blocks

### Metal scraper

- 1 Metal scraper
  - Material: stainless spring steel to EN 10088
  - Finish: bright
- 2 Spacer plate
  - Material: aluminum

### Mounting instructions:

Comes complete with spacer plate and mounting screws (the lube nipple is not included).

When mounting the scraper, make sure there is a uniform gap between the guide rail and the scraper.

For lubricating from the end face:  
Bore open hole  $S_2$  in the spacer plate.  
Lube nipples, see "Accessories".

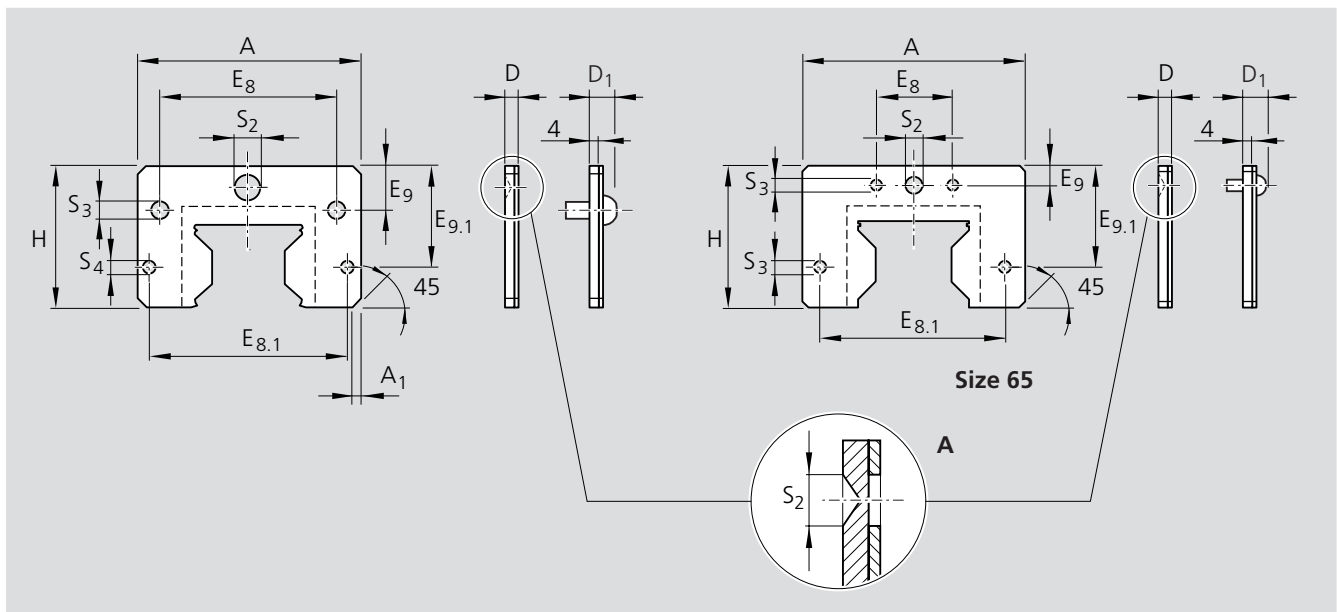
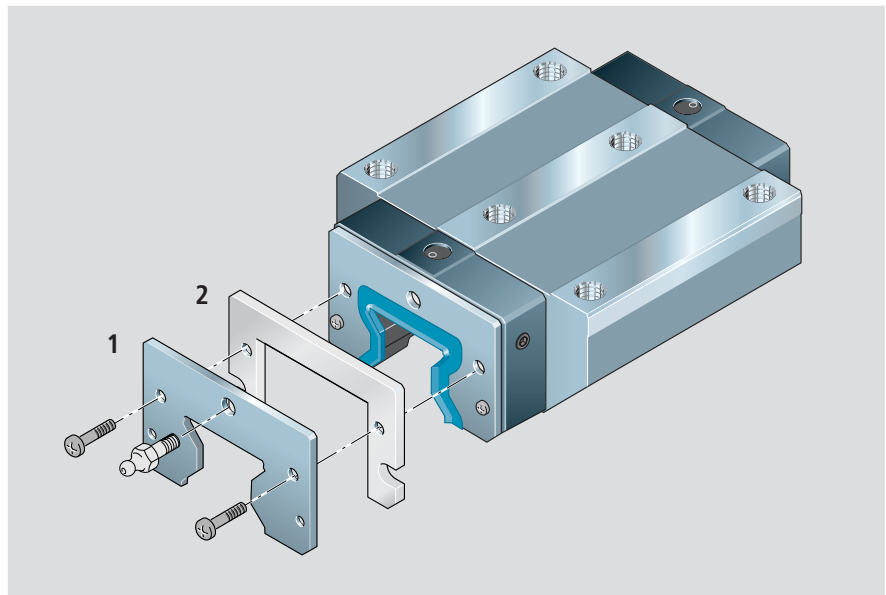

### Part numbers, dimensions and weights

Size 25:  
for 0.15 mm cover strip

Sizes 35 - 65:  
for 0.30 mm cover strip

Size	Part numbers	Dimensions (mm)											Weight (g)	
		A	A <sub>1</sub>	H	E <sub>8</sub>	E <sub>8.1</sub>	E <sub>9</sub>	E <sub>9.1</sub>	dia. S <sub>2</sub> <sup>1)</sup>	dia. S <sub>3</sub>	dia. S <sub>4</sub>	D		D <sub>1</sub>
25	1820-210-00	44.0	1.2	28.5	33.4	40.2	7.9	20.9	7	4	3	5	7.00	22
35	1820-310-40	63.0	2.0	39.8	50.3	56.6	12.4	28.4	7	4	3	5	7.50	30
45	1820-410-40	77.0	2.0	49.8	62.9	69.6	16.0	35.8	7	5	4	6	9.00	71
55	1820-510-40	90.5	2.0	56.2	74.2	81.6	18.2	40.0	7	6	4	6	9.25	96
65	1820-610-40	119.0	3.0	74.5	35.0	106.0	8.3	54.0	7	5	5	6	8.75	170

<sup>1)</sup> Rough-drilled hole in spacer plate.  
Bore open as required.

# Accessories for Standard Runner Blocks

## One-piece Viton wiper seal for mounting on the runner block

- Material:  
stainless steel frame with integral Viton seal

### Mounting instructions:

Comes complete with mounting screws (the lube nipple is not included).

For lubricating from the end face:  
Bore open hole  $S_2$ .  
Lube nipples, see "Accessories".

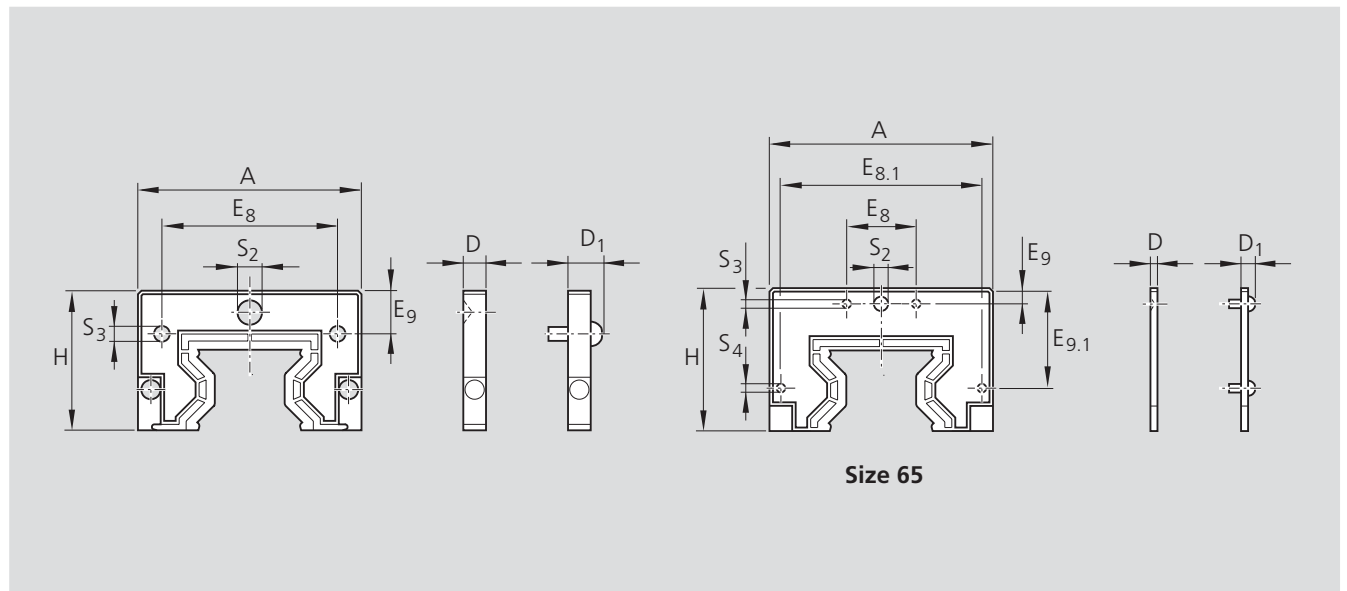
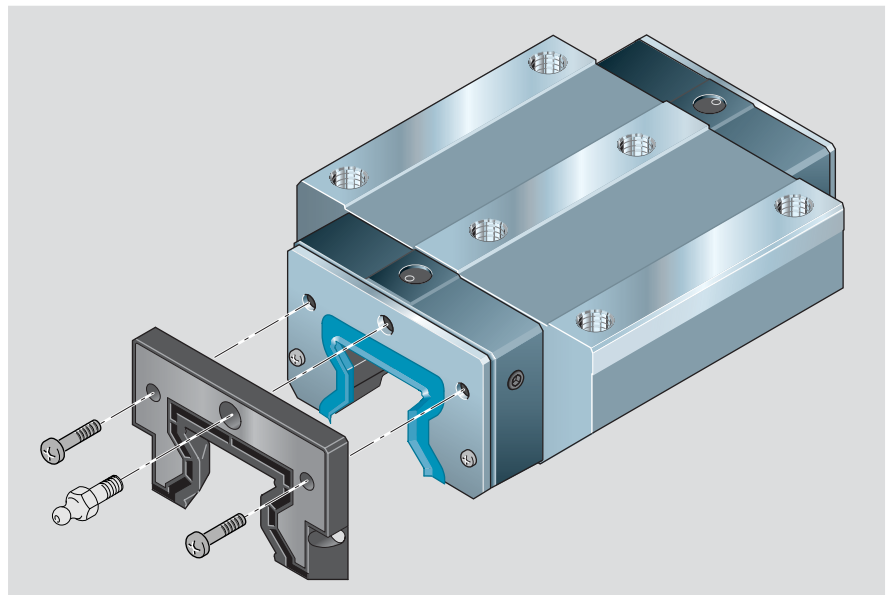

## Part numbers, dimensions and weights

Size	Part numbers	Dimensions (mm)									Weight (g)	
		A	H	E <sub>8</sub>	E <sub>8.1</sub>	E <sub>9</sub>	E <sub>9.1</sub>	dia. S <sub>2</sub> <sup>1)</sup>	dia. S <sub>3</sub>	D		D <sub>1</sub>
25	1810-200-30	44.0	29.5	33.4	–	7.75	–	–	4	6.25	8.25	20
35	1810-300-30	64.0	40.0	50.3	–	12.35	–	7	4	6.50	9.00	40
45	1810-400-30	78.0	50.0	62.9	–	16.00	–	7	5	6.50	9.50	60
55	1810-500-30	91.5	57.0	74.2	–	18.20	–	7	6	6.50	9.75	80
65	1810-600-30	119.0	77.0	35.0	106	8.55	54.25	7	5	6.50	9.25	160

<sup>1)</sup> Rough-drilled hole.  
Bore open as required.

# Rexroth Roller Rail Systems

## Accessories for Standard Runner Blocks

### One-piece Viton wiper seal for mounting on the machine carriage as a distributed element

Variant:

- for mounting on the machine carriage (not to the runner block)
- with recess for machine bed wiper

Material:

- stainless steel frame with integral Viton seal

#### Mounting instructions:

Comes complete with mounting screws.

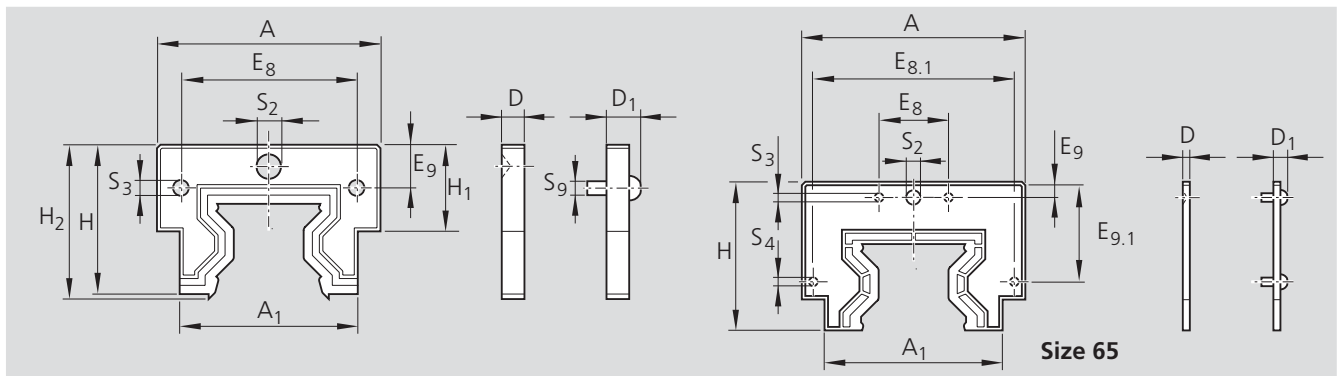
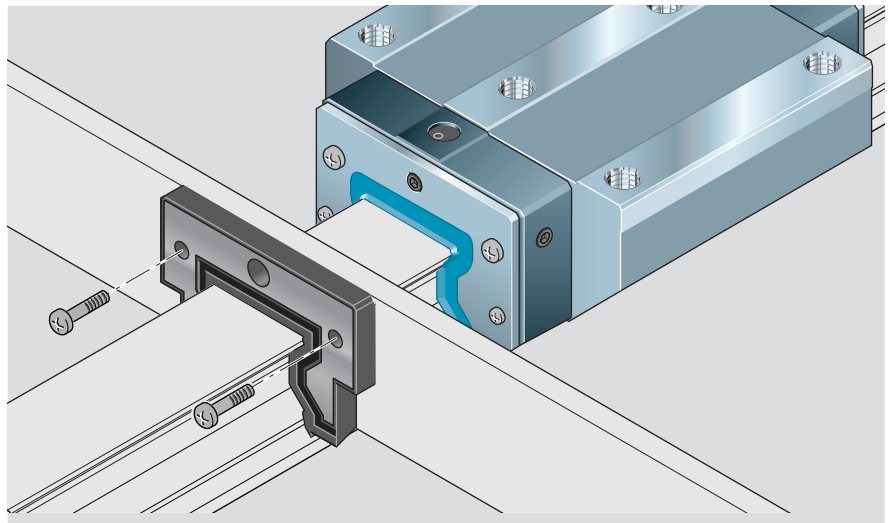

#### Part numbers, dimensions and weights

Size	Part numbers	Dimensions (mm)											Weight			
		A	A <sub>1</sub>	H	H <sub>1</sub>	H <sub>2</sub>	E <sub>8</sub>	E <sub>8.1</sub>	E <sub>9</sub>	E <sub>9.1</sub>	dia. S <sub>2</sub> <sup>1)</sup>	dia. S <sub>3</sub>	dia. S <sub>9</sub>	D	D <sub>1</sub>	(g)
25	1810-200-40	44.0	31.5	31.2	13.5	33.00	33.4	–	7.75	–	–	4	M3	6.25	8.25	18
35	1810-300-40	64.0	51.0	42.75	24.8	44.20	50.3	–	12.35	–	7	4	M3	6.50	9.00	35
45	1810-400-40	77.0	65.0	53.75	36.0	55.35	62.9	–	16.00	–	7	5	M4	6.50	9.50	58
55	1810-500-40	90.5	78.5	60.75	43.0	62.55	74.2	–	18.20	–	7	6	M5	6.50	9.75	78
65	1810-600-40	119.0	106.0	79.95	62.2	79.95	35.0	106	8.55	54.25	7	5	M4	6.50	9.25	160

<sup>1)</sup> Rough-drilled hole. Bore open as required.

Size	H matching h <sub>1</sub>	
	h <sub>1</sub>	Tolerance
25	4.5	± 0.1
35	5	+ 0.1 – 0.2
45	6	+ 0.1 – 0.2
55	9	+ 0.1 – 0.2
65	10	0 – 0.3

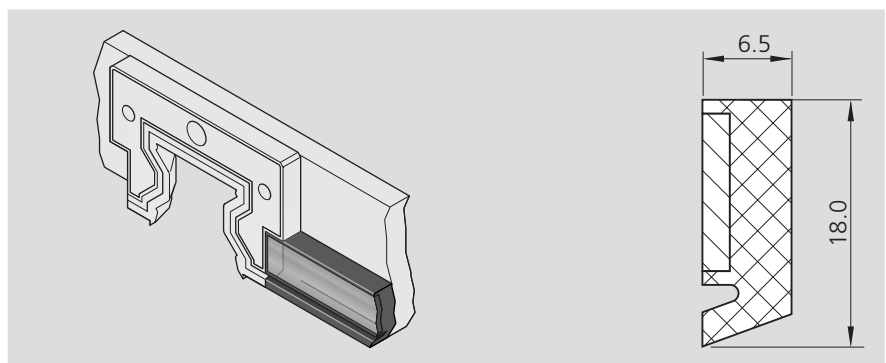
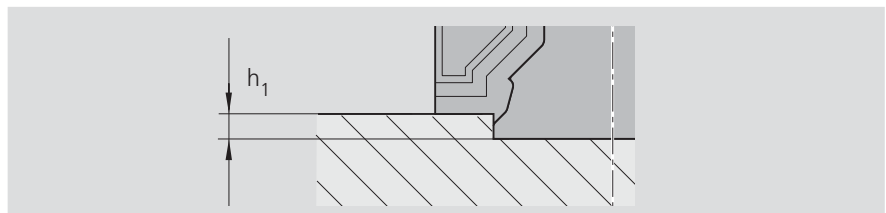

### Machine bed wiper for Viton wiper seal -40

Length: 500 mm

Part number: 8411-070-04

#### Mounting instructions:

The mounting holes are to be drilled by the customer as required.

# Accessories for Standard Runner Blocks

## Two-piece Viton / NBR wiper seal

- Material:  
stainless steel frame plus Viton or NBR seal

### Mounting instructions:

Comes complete with mounting screws.

For lubricating from the end face:  
Lube nipples, see "Accessories".

Easy mounting / removal with the guide rail  
fixed in place.

Observe the mounting instructions.

Can be combined with an addition metal  
scraper; please consult us.

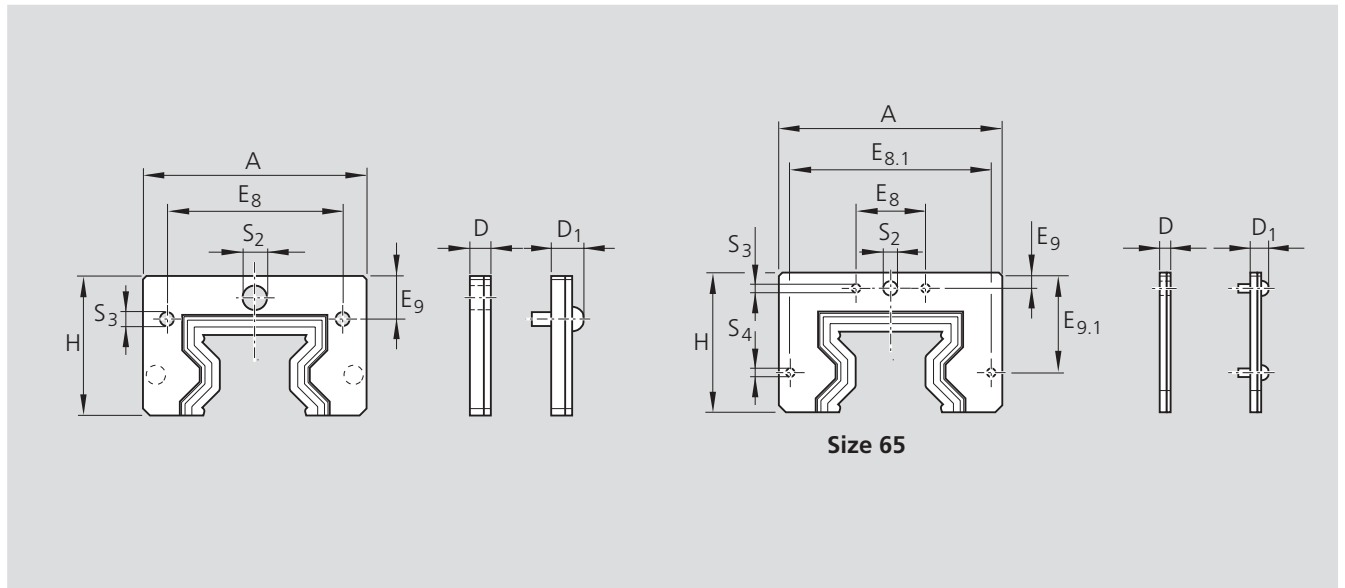
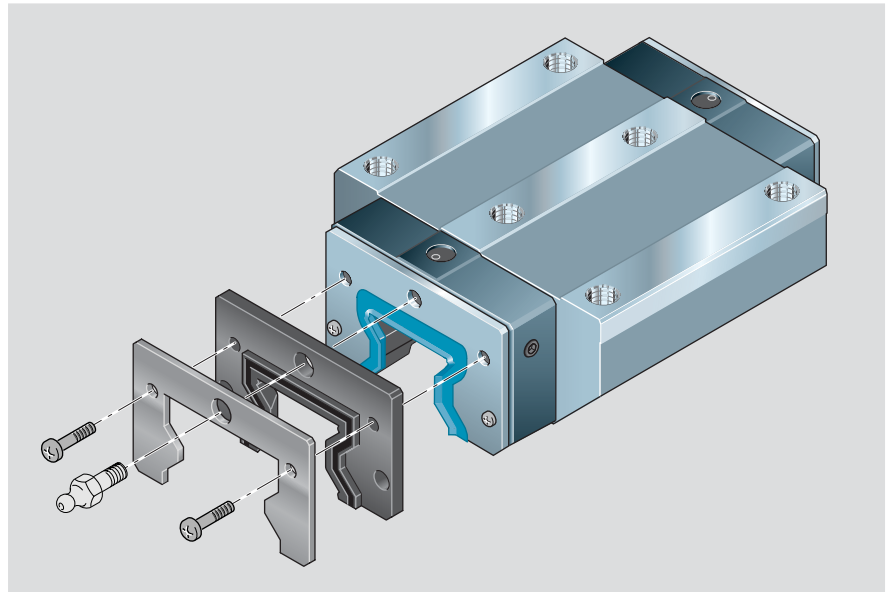

### Part numbers, dimensions and weights

#### Viton wiper seal

Size	Part numbers	Dimensions (mm)										Weight (g)
		A	H	E <sub>8</sub>	E <sub>8.1</sub>	E <sub>9</sub>	E <sub>9.1</sub>	dia. S <sub>2</sub>	dia. S <sub>3</sub>	D	D <sub>1</sub>	
25*	1810-200-70	-	-	-	-	-	-	-	-	-	-	-
35	1810-300-70	64.0	40.0	50.3	-	12.35	-	7	4	6.0	8.50	40
45	1810-400-70	78.0	50.0	62.9	-	16.00	-	7	5	6.0	9.00	60
55	1810-500-70	91.5	57.0	74.2	-	18.20	-	7	6	6.5	9.75	80
65	1810-600-70	119.0	75.0	35.0	106	8.55	54.25	7	5	6.5	9.25	160

### Part numbers, dimensions and weights

#### NBR wiper seal

Size	Part numbers	Dimensions (mm)										Weight (g)
		A	H	E <sub>8</sub>	E <sub>8.1</sub>	E <sub>9</sub>	E <sub>9.1</sub>	dia. S <sub>2</sub>	dia. S <sub>3</sub>	D	D <sub>1</sub>	
25*	1810-200-90	-	-	-	-	-	-	-	-	-	-	-
35	1810-300-90	64.0	40.0	50.3	-	12.35	-	7	4	6.0	8.50	40
45	1810-400-90	78.0	50.0	62.9	-	16.00	-	7	5	6.0	9.00	60
55	1810-500-90	91.5	57.0	74.2	-	18.20	-	7	6	6.5	9.75	80
65	1810-600-90	119.0	75.0	35.0	106	8.55	54.25	7	5	6.5	9.25	160

\* In preparation

# Rexroth Roller Rail Systems

## Accessories for Standard Runner Blocks

### Standard lube plate

- Material: aluminum
- for standard lube nipples

### Mounting instructions:

Comes complete with all the necessary parts for the various mounting options.

The runner block lube nipple can be used.

Refer to "Mounting Instructions for Roller Rail Systems".

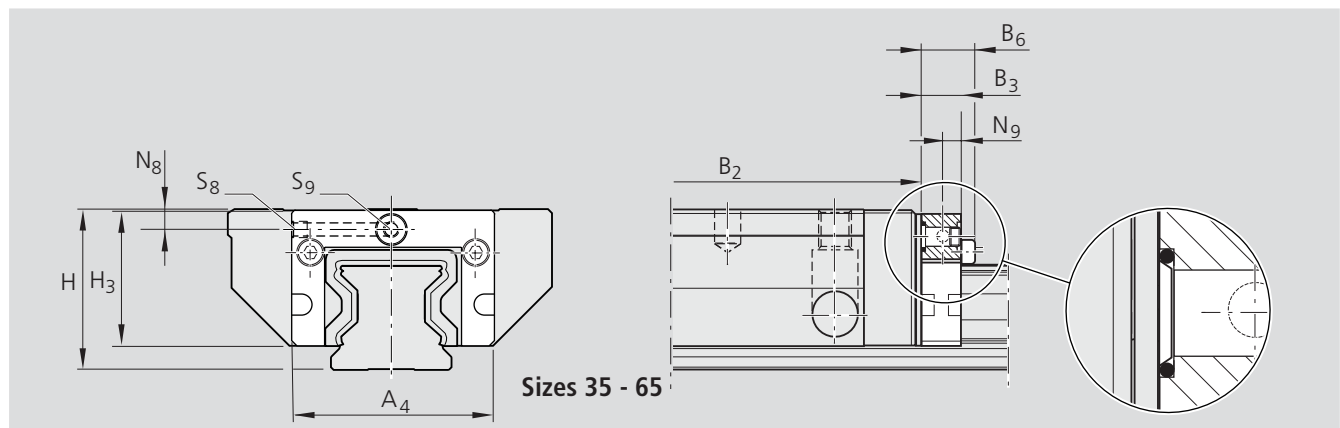
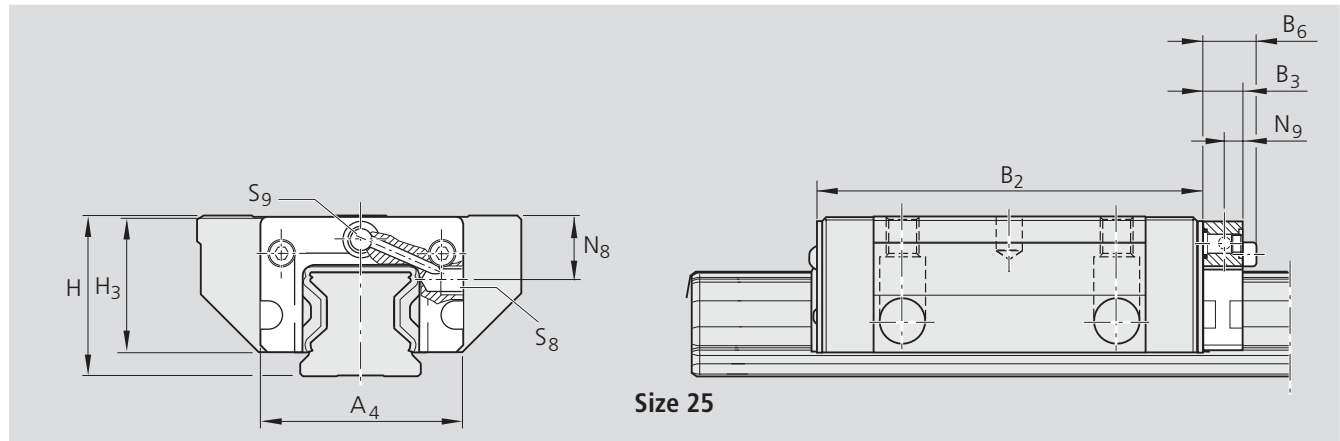
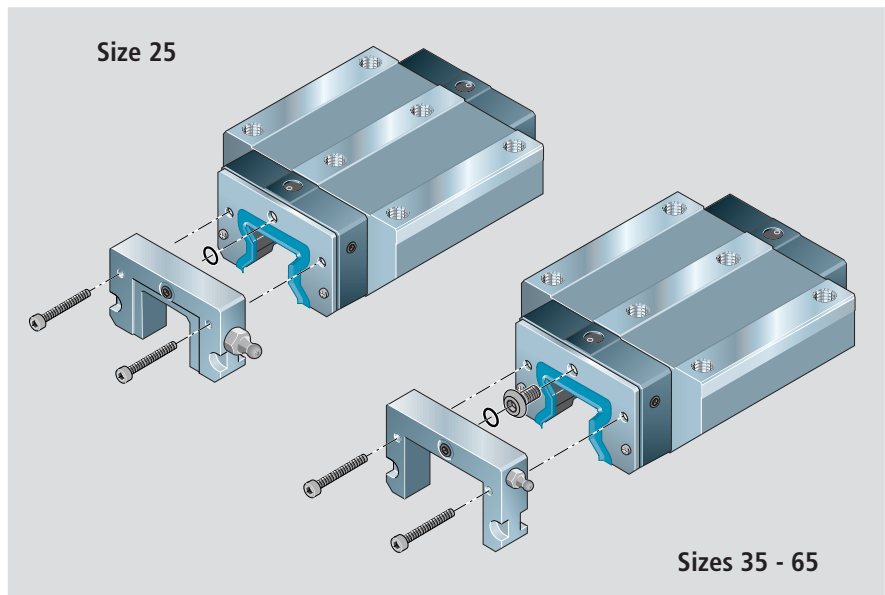

### Part numbers, dimensions and weights

Size	Part numbers	Dimensions (mm)									Weight (g)
		A <sub>4</sub>	B <sub>3</sub>	B <sub>6</sub>	H	H <sub>3</sub>	N <sub>8</sub> <sup>1)</sup>	N <sub>9</sub>	S <sub>8</sub>	S <sub>9</sub>	
25	1820-211-20	44.0	12	15	36	28.30	14.0	6	M6	M6	32
35	1820-311-20	69.0	12	15	48	39.75	7.0	6	M6	M6	60
45	1820-411-20	77.0	12	16	60	49.75	8.0	6	M6	M6	70
55	1820-511-20	90.5	12	17	70	56.00	9.0	6	M6	M6	90
65	1820-611-20	119.0	12	16	90	74.50	18.0	6	M6	M6	200

<sup>1)</sup> Referred to the runner block mounting face

# Accessories for Standard Runner Blocks

## Lube plate G 1/8 / M8 x 1

- Material: aluminum
- Lube port  $S_8 = G1/8$  or
- Lube port  $S_8 = M8 \times 1$  for sizes 35 and 45
- Part numbers 1820-.11-40

### Mounting instructions:

Comes complete with all the necessary parts for the various mounting options.

With slimline runner block sizes 25 and 35, note that the lube plate protrudes on one side!

Refer to "Mounting Instructions for Roller Rail Systems".

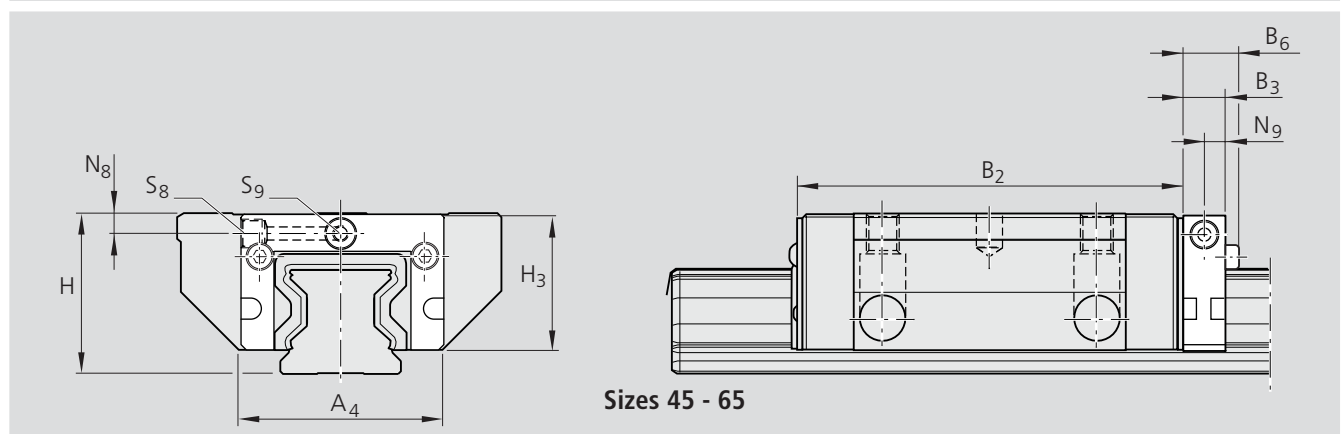
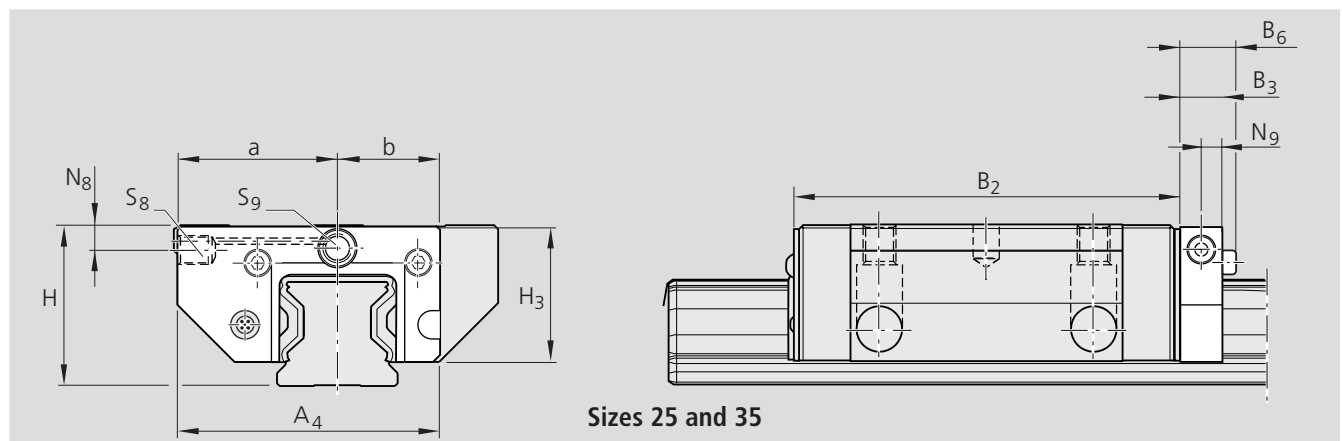
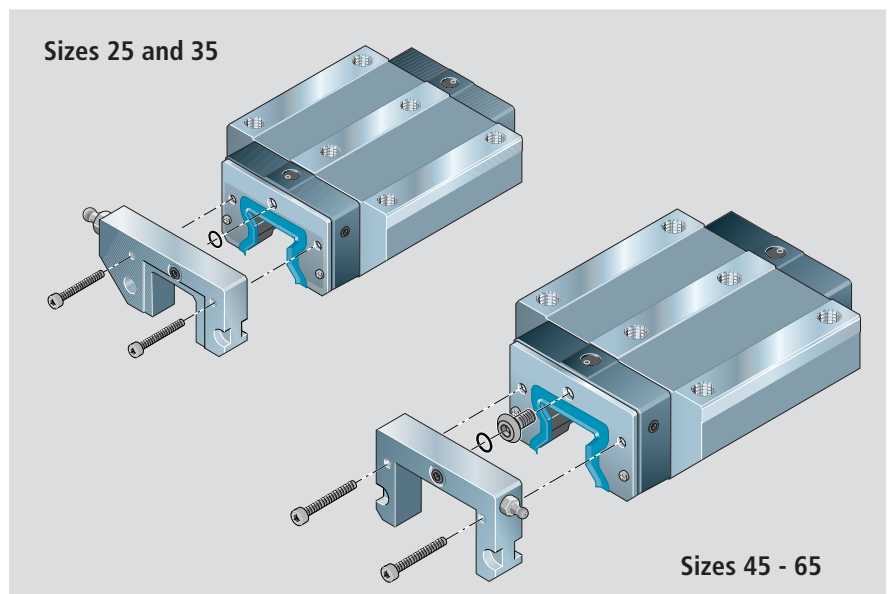

### Part numbers, dimensions and weights

Size	Part numbers <sup>2)</sup>	Dimensions (mm)											Weight (g)	
		$A_4$	$B_3$	$B_6$	a	b	H	$H_3$	$N_8$ <sup>1)</sup>	$N_9$	$S_8$	$S_9$		
25	1820-211-30	55.5	16	19	33.5	22	36	28.30	7.5	8	G1/8-8 deep	–	M6	32
35	1820-311-30	71.0	16	19	39.5	31.5	48	39.75	8.0	8	G1/8-8 deep	M8x1-8 deep <sup>2)</sup>	M6	72
45	1820-411-30	77.0	16	20	–	–	60	49.75	8.0	8	G1/8-8 deep	M8x1-8 deep <sup>2)</sup>	M6	90
55	1820-511-30	90.5	16	21	–	–	70	56.00	9.0	8	G1/8-8 deep	–	M6	115
65	1820-611-30	119.0	16	20	–	–	90	74.50	18.0	8	G1/8-8 deep	–	M6	240

<sup>1)</sup> Referred to the runner block mounting face

<sup>2)</sup> Part numbers 1820-.11-40

# Rexroth Roller Rail Systems

## Accessories for Standard Runner Blocks

### Lube adaptor

for high runner blocks 1821-/1824-

– Material: plastic

#### Mounting instructions:

Comes complete with all the necessary parts for the various mounting options.

Before mounting, bore open the lube hole in the runner block. Alternatively, a special runner block version with open lube hole can be ordered.

Send for "Mounting Instructions for Roller Rail Systems".

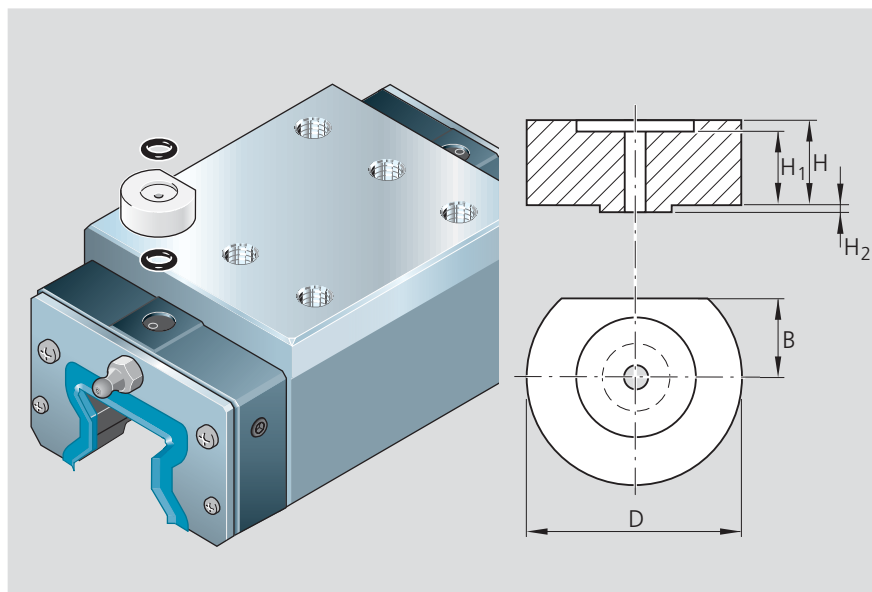

### Part numbers and dimensions

Size	Part numbers	Dimensions (mm)				
		D	B	H	H <sub>1</sub>	H <sub>2</sub>
25	1821-200-05	15	4.60	3.65	2.65	0.5
35	1821-300-05	18	6.55	7.00	6.00	0.5
45	1821-400-05	22	6.50	10.00	9.00	0.5
	1821-400-15 <sup>1)</sup>	22	6.50	10.00	9.00	0.5
55	1821-500-05	24	7.50	10.00	9.00	0.5

<sup>1)</sup> For aluminum end caps



# Accessories for Standard Runner Blocks

## Front Lube Units

### Advantages during mounting and in service:

- Up to 5000 km travel
- Only initial lubrication of the runner block necessary
- Front lube units at both runner block ends
- Minimal lubricant loss
- Reduced oil consumption
- No lube lines
- Max. operating temperature 60°C

- ▶ In-service refilling possible using lube nipple on end face or side
- ▶ Size 25: lube port on end face suitable for lubricating runner block with grease

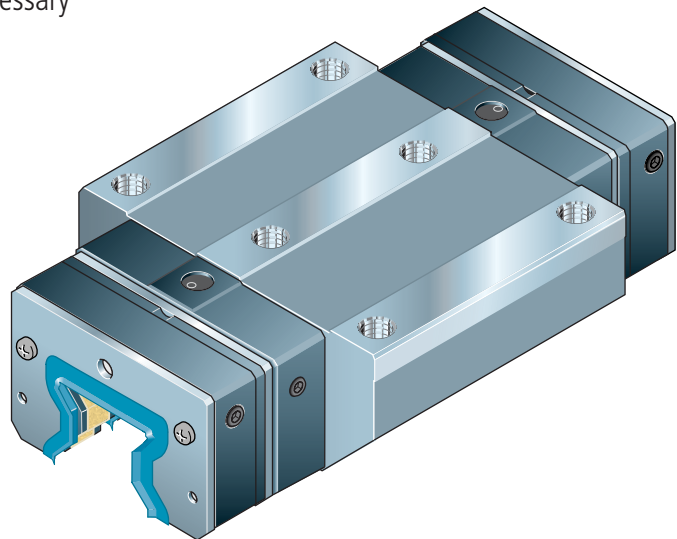

### Rexroth Roller Rail Systems

#### Runner block with two front lube units and end seals

### Oil consumption comparison, size 35

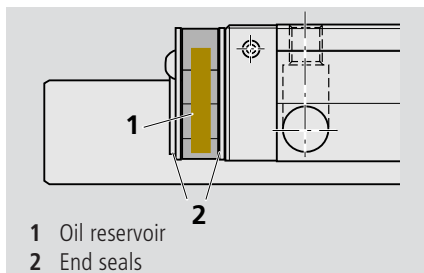

Front lube units	Lubricant quantity per lubrication cycle (cm <sup>3</sup> )	Travel (m)	Consumption (cm <sup>3</sup> /km)
without	1.3	20 000	0.065 → 100%
<b>with</b>	<b>16.6</b>	<b>5 000 000</b>	<b>0.0033 → 5.08%</b>

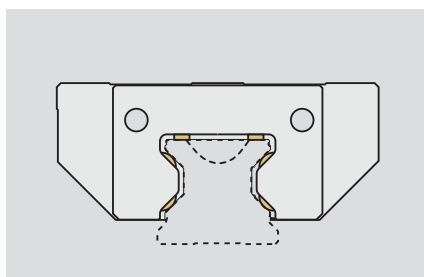

Specially designed distribution channels ensure that the lubricant is applied only where needed: directly to the raceways and to the guide rail surface.

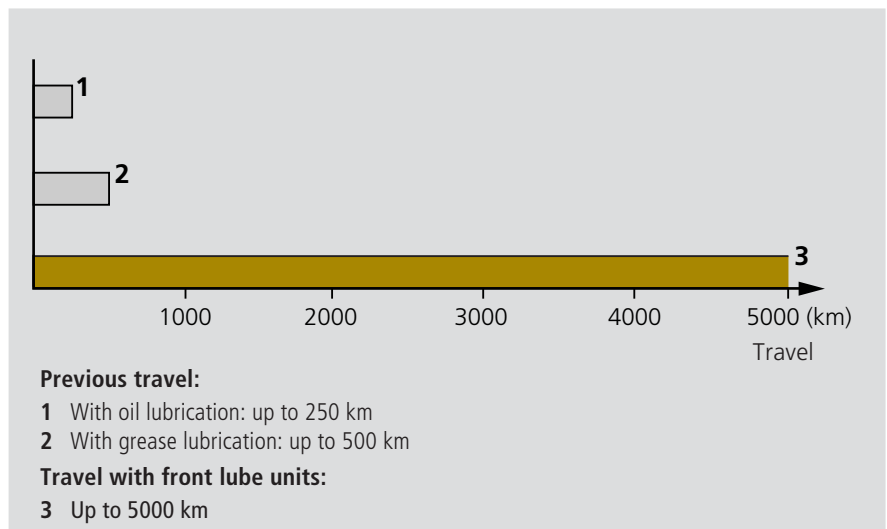

# Rexroth Roller Rail Systems

## Accessories for Standard Runner Blocks

### Front lube units for roller rail systems

– Material: special plastic

#### Mounting instructions:

Front lube units are supplied complete with coated screws, additional end seals and lube nipple.

Front lube units with ...-00 part numbers (see table below) are supplied ready-filled with oil and can be mounted immediately after greasing the runner block.

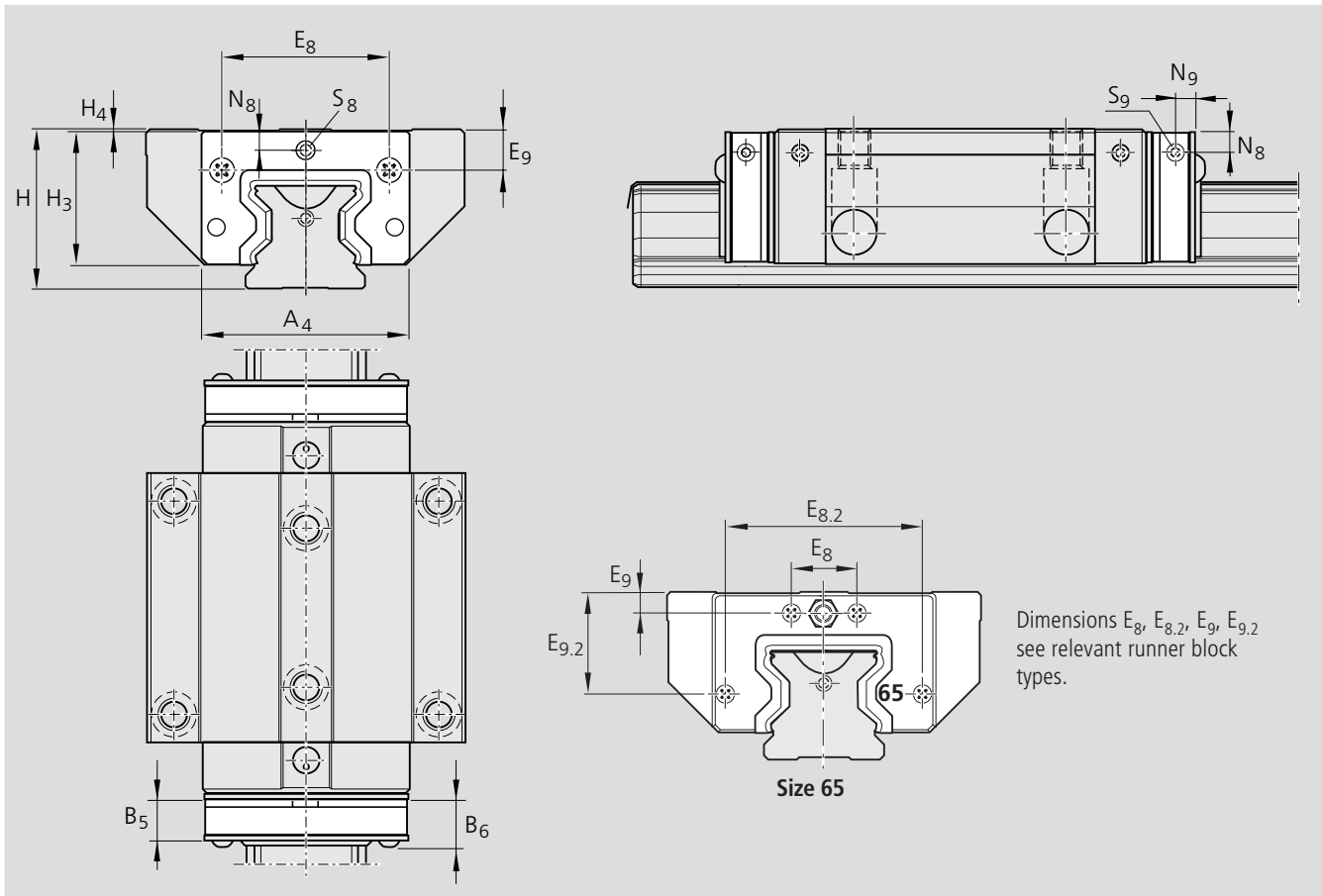
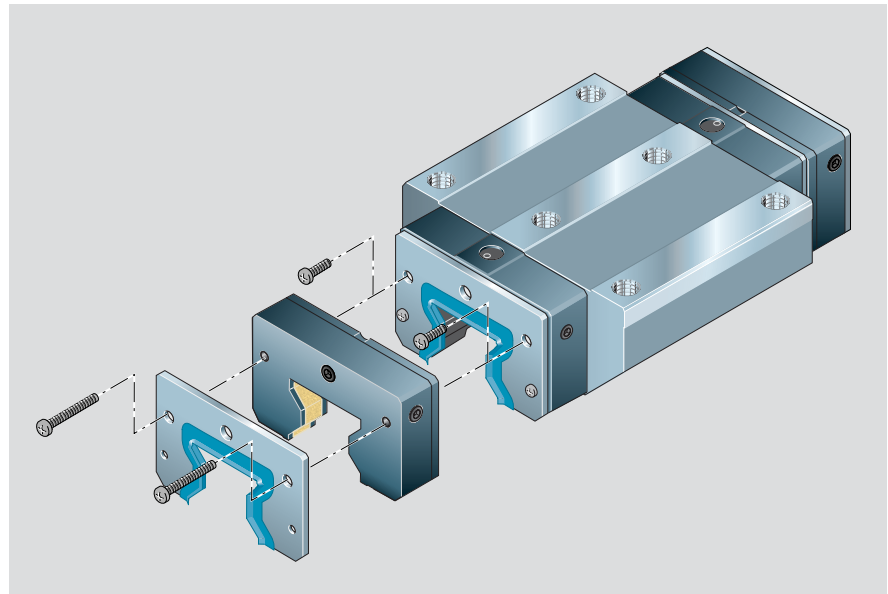

### Part numbers and dimensions

Size	Part numbers	Dimensions (mm)										Oil (cm <sup>3</sup> )
		$A_4$	$B_5$	$B_6$	H	$H_3$	$H_4$	$N_8$	$N_9$	$S_8$	$S_9$	
25	1810-225-00	44.0	13.0	15.5	36	29.2	0.50	5.00	–	M6	–	2.6
35	1810-325-00	64.0	16.5	19.0	48	40.0	0.75	6.25	5.5	M6	M6	8.3
45	1810-425-00	78.0	18.5	21.8	60	50.0	0.75	7.25	7.5	M6	M6	13.8
55	1810-525-00	91.5	20.3	24.3	70	56.3	0.75	8.25	9.0	M6	M6	22.8
65	1810-625-00	119.0	21.0	24.3	90	74.8	0.75	8.55	8.5	M6	M6	47.6

# Accessories for Standard Runner Blocks

## Initial lubrication of the runner block

**⚠** Before mounting the front lube units, always lubricate the runner blocks first **using grease!**

### Recommended grease types:

- Paragon EP 1, from DEA, KP 1 N-30
- Optimol Longtime PD 1, from Optimol Oelwerke, KP 1 N-40
- Optimol Longtime PD 2, from Optimol Oelwerke, KP 2 N-40
- Klüber Isoflex NCA 15
- Klüber Polyub GLY 151
- Klüber Microlube GL 261

## Lubricating the runner block

**☞** If there already is grease in the runner block, or if grease types other than those recommended have to be used, refer to the "Lubricant compatibility" section.

1. Grease the runner block as specified in the table.
2. Slide runner blocks back and forth over at least three times the block length for three full cycles.
3. Repeat steps 1. and 2. twice more.
4. Check whether a film of lubricant is visible on the guide rail.

Size	Partial lubricant quantity for initial lubrication of the runner block (cm <sup>3</sup> )
25	0.8
35	0.9
45	1.0
55	1.4
65	2.7

## Front lube units

### As-supplied condition

There are two types of front lube units. The part numbers stand for:  
 ....-...-00: ready to mount and filled with lube oil  
 ....-...-10: without lube oil filling

### Initial filling of an unfilled front lube unit (part numbers ....-...-10)

Recommended lube oil:

- Mobil SHC 639 (viscosity 1000 mm<sup>2</sup>/s at 40°C)

**☞** If other oils have to be used, see "Lubricant compatibility".

- Remove the set screw from the lube hole (1) and keep it ready for later use.
- Screw in lube nipple (2).
- Lay front lube units (3) down flat and fill with quantity of oil specified in the table. Leave in that position for 36 hours.

- Check whether the lube insert is completely soaked with oil. Add oil, if necessary.
- Remove lube nipple, screw in set screw.

Size	Oil quantity for initial filling of front lube unit (cm <sup>3</sup> )
25	☞ Figure B
35	8.3
45	14.6
55	22.8
65	47.6

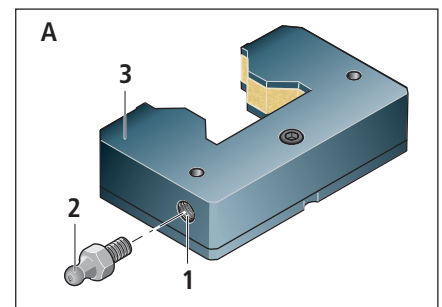

- For size 25: Stand the front lube units in oil 10 mm deep for 36 hours (☞ Fig. B).

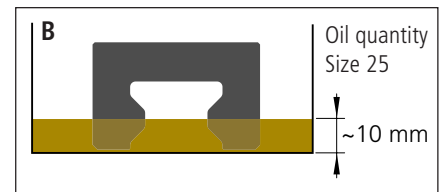

# Rexroth Roller Rail Systems

## Accessories for Standard Runner Blocks

### Lubricant compatibility

Synthetic base lubricants are superior to those with a mineral oil base, and especially to paraffin oils.

The standard filling in the front lube units is Mobil SHC 639. This oil is a fully synthetic lubricant with a synthetic hydrocarbon base (polyalphaolefins).

Mobil SHC 639 can be mixed with mineral base oils in any proportion. Compatibility with Rexroth anti-corrosion oil is assured.

Mobil SHC 639 is also chemically compatible with lubricant greases with a synthetic hydrocarbon oil, polyalphaolefin, mineral oil or ester oil base.

**⚠** If other lubricants are used, check compatibility of lube oil and grease.

Minimum requirements for other lube oils: ISO viscosity class 1000 to DIN 51519, without solid particles, e.g. CLP lube oil to DIN 51517, part 3.

**👁** Lube oils must be chemically and physically comparable to Mobil SHC 639 oil.

**⚠** Compatibility problems can be expected particularly with grease lubricants with a silicone oil, polyglycol oil, polyphenyl ether oil or perfluoroalkyl ether oil base.

### Mounting instructions for the front lube unit

Front lube units are supplied complete with all the necessary coated screws, additional end seals and lube nipple.

**⚠** Mount one front lube unit (3) at each end of the runner block.

**⚠** Do not remove runner blocks from the rail!

- Remove screws (6) – in size 65, there are four screws. Discard these screws (6)!
- If there are any end seals (7) already mounted on the runner block, leave them in place.
- Slide on the front lubrication units (3) and the additional end seals (5) and align them with the runner block.
- For size 25, remove the set screw (9) and insert the O-ring (8) between the runner block and the front lubrication unit.

**⚠** Mount additional end seals (5) so that the sealing lips fit snugly all around the guide rail.

- Tighten screws (4) with tightening torque  $M_A$ .

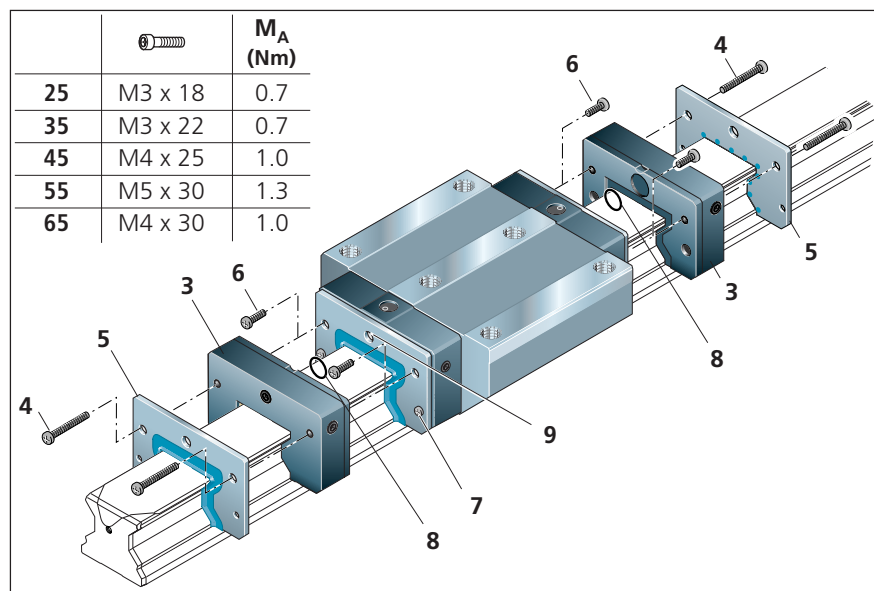

## In-service lubrication intervals for runner blocks

- Check the front lubrication units when the system has covered the travel distance specified in the table.

The travel specification applies to:

- normal operating conditions and the load specified in the table.

We recommend replacing the front lube units when the specified travel (see table) has been reached or, at the latest, after 3 years. Before mounting the new front lube units, the runner block has to be relubricated with grease.

In clean operating environments, the front lube units can be refilled with oil. Runner block sizes 35–65 can be regreased from the side and size 25 runner blocks from the end.

See “Initial lubrication of the runner block” and/or “Initial filling of an unfilled front lube unit” for lubricant quantities.

 Longer travel has already been recorded in ongoing nominal life tests. Please consult us as necessary!

Size	Travel under normal operating conditions (km)
	Load $\leq 0.15 C$
25	5000
35	5000
45	3000
55	2000
65	1000

 The recommended in-service lubrication intervals depend on environmental factors, load and type of loading.

Typical environmental factors include fine metal particles, mineral and similar abraded material, solvents, and temperature. Load types include vibrations, impacts and tilting.

 The service conditions are unknown to the manufacturer. Users can only determine the in-service lubrication intervals with certainty by conducting their own in-house tests or by close observation.

 Do not allow the guide rails and runner blocks to come into contact with aqueous coolants!

# Rexroth Roller Rail Systems

## Accessories for Standard Runner Blocks

### Protective bellows

- Material: bellows-type protective cover of polyurethane-coated polyester fabric
  - For size 25:
    - aluminum lube plates
- The runner block lube nipple can be used.

### Heat resistant bellows

- Material: Nomex fabric, metallized on both sides
  - Non combustible, non flammable
  - Resistant to sparks, welding splashes and hot chips
  - Temperature resistance:
    - Peak temperatures of up to 200°C near the protective metal coat possible.
    - Operating temperature for the entire bellows: 100°C
- Available in sizes 25, 35, 45, 55.
- The runner block lube nipple can be used.

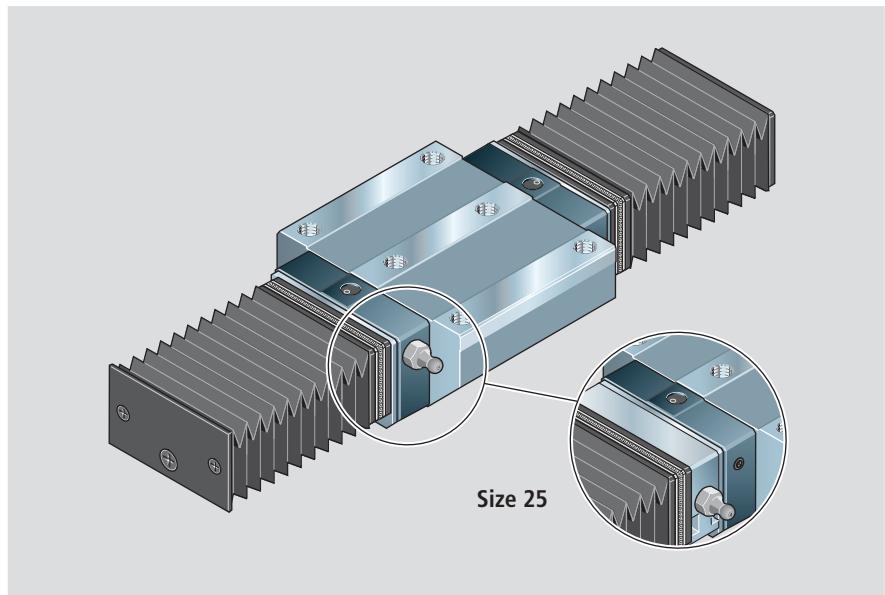

Size	Type 1		Type 2		Type 3	
	With lubrication plate and end plate	Number of folds	With mounting frame and end plate	Number of folds	With 2 lubrication plates	Number of folds
	25	1820-201-00	...	1820-202-00	...	1820-203-00
35	–	...	1820-302-00	...	–	...
45	–	...	1820-402-00	...	–	...
55	–	...	1820-502-00	...	–	...
65	–	...	1820-602-00	...	–	...
25	1820-251-00	...	1820-252-00	...	1820-253-00	...
35	–	...	1820-352-00	...	–	...
45	–	...	1820-452-00	...	–	...
55	–	...	1820-552-00	...	–	...

### Part numbers, protective bellows

#### Ordering example, protective bellows

Size 35, Type 2,  
Number of folds: 36  
1820-302-00, 36 folds

### Part numbers, heat resistant bellows

#### Ordering example, heat resistant bellows

Size 35, Type 2,  
Number of folds: 36  
1820-352-00, 36 folds

Size	Type 4		Type 5		Type 9	
	With 2 mounting frames	Number of folds	With lubrication plate and mounting frame	Number of folds	Bellows (spare part)	Number of folds
	25	1820-204-00	...	1820-205-00	...	1600-209-00
35	1820-304-00	...	–	...	1600-309-00	...
45	1820-404-00	...	–	...	1600-409-00	...
55	1820-504-00	...	–	...	1600-509-00	...
65	1820-604-00	...	–	...	1600-609-00	...
25	1820-254-00	...	1820-255-00	...	1600-259-00	...
35	1820-354-00	...	–	...	1600-359-00	...
45	1820-454-00	...	–	...	1600-459-00	...
55	1820-554-00	...	–	...	1600-559-00	...

### Part numbers, protective bellows

### Part numbers, heat resistant bellows

# Accessories for Standard Runner Blocks

## Mounting instructions

The bellows are delivered preassembled, complete with mounting screws.

In types 1 and 2, a tapped hole size M4, 10 mm deep and countersunk 2 x 45°, must be drilled into each end face of the rail.

Sizes 25 - 65:

The runner block lube nipple can be used.

See "Mounting Instructions, Bellows" for mounting.

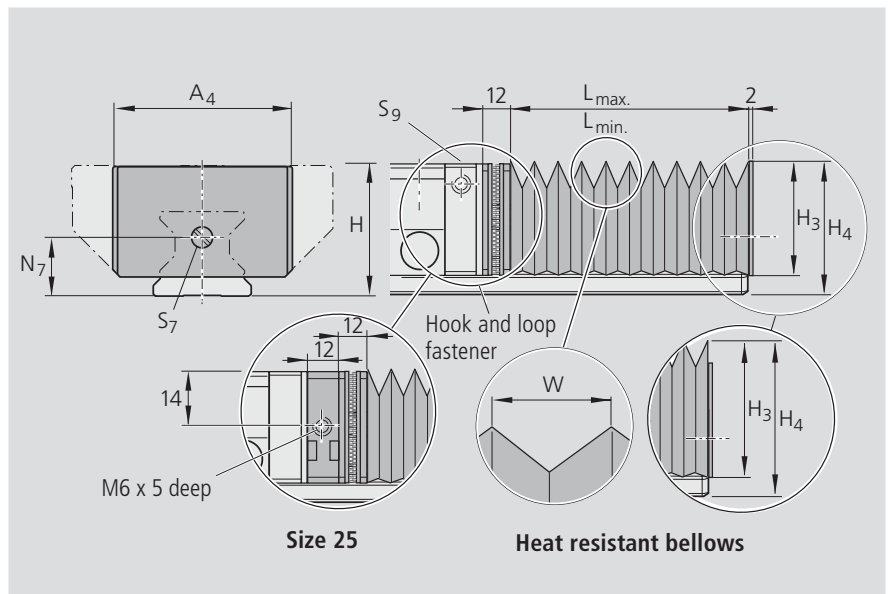

## Dimensions, bellows

Size	Dimensions (mm)								Factor U
	A <sub>4</sub>	H	H <sub>3</sub>	H <sub>4</sub>	N <sub>7</sub>	S <sub>7</sub>	S <sub>9</sub>	W	
25	45	36	28.5	35.0	15	M4	–	12.9	1.32
35	64	48	39.0	47.0	22	M4	M6	19.9	1.18
45	83	60	49.0	59.0	30	M4	M6	26.9	1.13
55	96	70	56.0	69.0	30	M4	M6	29.9	1.12
65	120	90	75.0	89.0	40	M4	M8x1	40.4	1.08

## Dimensions, heat resistant bellows

Size	Dimensions (mm)								Factor U
	A <sub>4</sub>	H	H <sub>3</sub>	H <sub>4</sub>	N <sub>7</sub>	S <sub>7</sub>	S <sub>9</sub>	W	
25	62	36	39.0	44.5	15	M4	–	25.9	1.25
35	74	48	46.0	54.0	22	M4	M6	29.9	1.21
45	88	60	54.0	64.0	30	M4	M6	32.9	1.18
55	102	70	62.0	75.0	30	M4	M6	37.9	1.16

## Bellows calculation

$$L_{\max} = (\text{Stroke} + 30) \cdot U$$

$$L_{\min} = L_{\max} - \text{Stroke}$$

$$\text{Number of folds} = \frac{L_{\max}}{W} + 2$$

L<sub>max</sub> = bellows extended

L<sub>min</sub> = bellows compressed

Stroke = stroke (mm)

U = calculation factor

W = maximum extension (mm)

## Rail length calculation

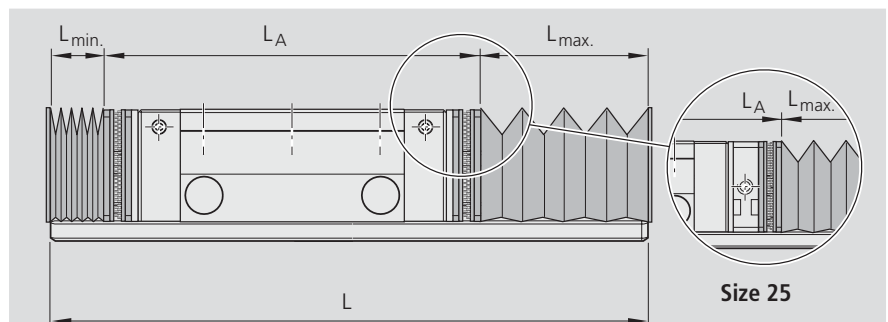

$$L = L_{\min} + L_{\max} + L_A$$

L = rail length (mm)

# Rexroth Roller Rail Systems

## Accessories for Standard Runner Blocks

### a) Mounting the bellows to the runner block (types 2 and 4), including mounting at the rail end (types 2 and 1)

Type 2 and type 1 only:

- Before mounting the bellows, drill and tap a hole in the end face of the guide rail (5), see dimensions  $N_7$  and  $S_7$  in the table and diagram alongside "Mounting instructions" on the previous page.

Types 2 and 4:

- If there is a lube nipple in the front lube hole (1), remove it and screw it into a lateral lube hole (relubrication side) (3).
- Use a set screw (2) to plug the open lube hole.
- Remove the upper mounting screws from the scraper plate.
- Screw the mounting frame with hook and loop fastener (4) to the runner block using the screws supplied along with the bellows.
- Push on the bellows.

Type 2 and type 1 only:

- Once the bellows are installed, screw them tight to the end of the rail (5).

For all types:

### Hook and loop fastener for the mounting frame (4)

- Position the bellows at one side.
- Make sure the fastener is properly aligned!
- Press on firmly!

Disconnecting the hook and loop fastener:

- Use a flat tool.
- Start at one side (preferably a corner) and carefully lever the two halves apart.

**⚠ Be careful not to shear off the hook and loop fastener!**

b) Size 25 only:

### Mounting the lubrication plate and the bellows (type 1, type 3 and type 5)

In size 25, the lube port is hidden by the bellows. Consequently, a lube plate has to be fitted to at least one side of a runner block for in-service lubrication. The lube plate can be turned round, thus allowing lubrication from the preferred side.

- Remove the lube nipple (1) or set screw (2) from the runner block (relubrication side).
- Screw the lube nipple (3) into the side of the lube plate (6).
- Insert the O-ring (7) into the recess.
- Screw the lube plate (6) and the mounting frame (4) to the runner block.
- Plug unused lube hole with set screw.

**⚠ Set screws must lie flush with the outer surface of the lube plate.**

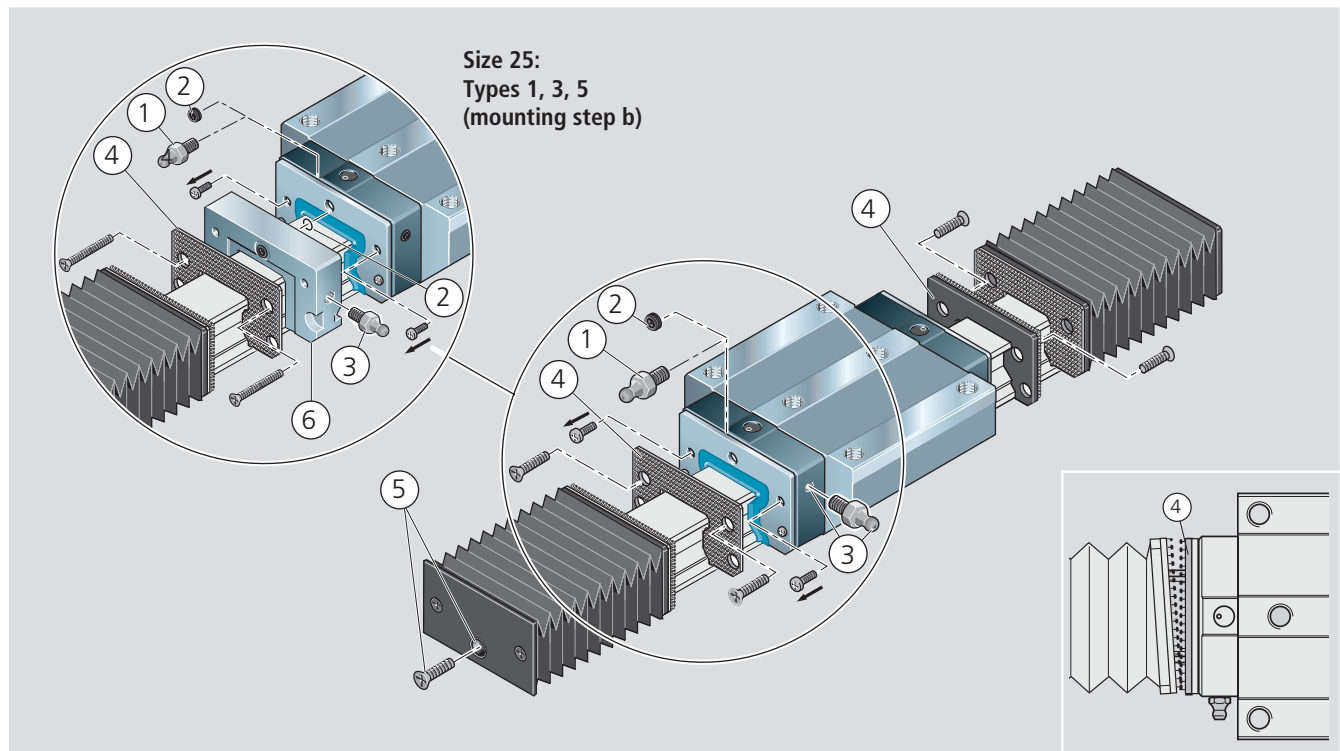



# Accessories for Guide Rails

## Cover strip, separate

(for initial mounting / as spare part / as replacement part)

A matching cover strip (sliding or snap fit) can be supplied for each rail length.

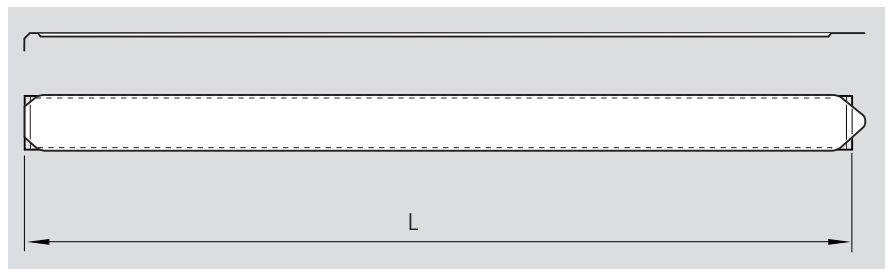

### Ordering a standard snap-fit cover strip

#### Ordering example:

Guide rail size 35  
Rail length L = 2696 mm

#### Ordering data:

Part number, length L (mm)

**1619-330-20, 2696 mm**

Size	Standard cover strips Part numbers, length (mm)
25	1619-230-00, ....
35	1619-330-20, ....
45	1619-430-20, ....
55	1619-530-20, ....
65	1619-630-20, ....
55/85	1810-532-20, ....
65/100	1810-632-20, ....
125	1810-331-20, ....

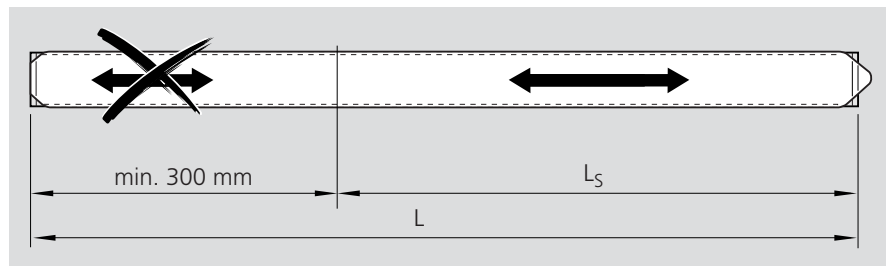

$L_s$  = sliding fit length

L = rail length

### Ordering a sliding-fit cover strip

#### Ordering example:

Guide rail size 35  
Rail length L = 2696 mm  
Sliding fit length  $L_s$  = 1200 mm

#### Ordering data:

Part number, length L (mm)

Sliding fit length  $L_s$  (mm)

**1619-330-30, 2696, 1200 mm**

Size	Cover strips with sliding fit Part numbers, length (mm)
25	1619-230-10, ....
35	1619-330-30, ....
45	1619-430-30, ....
55	1619-530-30, ....
65	1619-630-30, ....
55/85	1810-532-30, ....
65/100	1810-632-30, ....
125	1810-331-30, ....

Detailed information about how to order and mount cover strips is contained in our "Mounting Instructions for the Cover Strip" RDEFI 82 070.

# Rexroth Roller Rail Systems

## Accessories for Guide Rails

### Cover strip mounting kit

The kit comprises a mounting tool (A) for clipping on the cover strip and a lift-off plate (B) for removing the cover strip.

Size	Part numbers Mounting tool + lift-off plate
25	1619-210-70
35	1619-310-50
45	1619-410-50
55	1619-510-50
65	1619-610-50
55/85	1810-592-53
65/100	1810-692-53
125	1810-391-53

Detailed information is contained in our "Mounting Instructions for the Cover Strip" RDEFI 82 070.

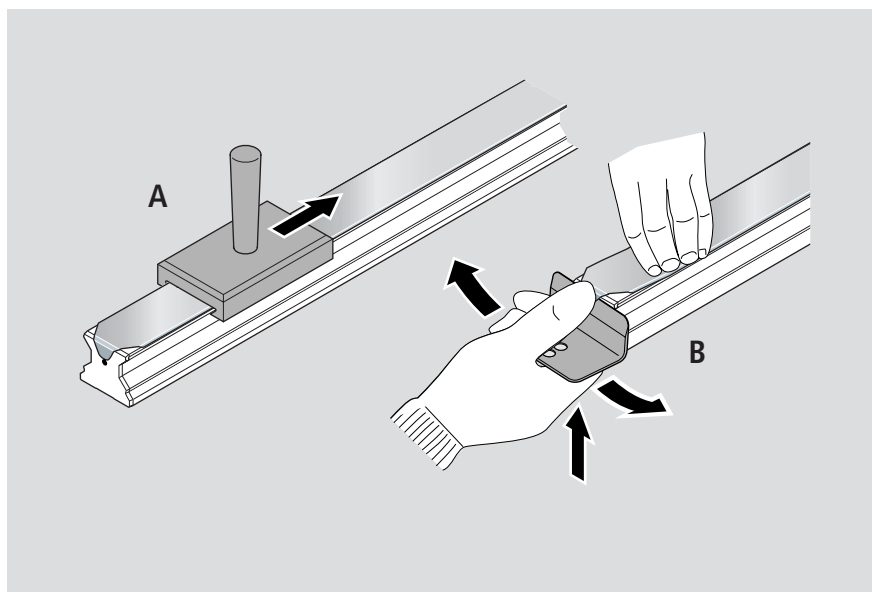

### Expanding tool for creating a sliding fit in the cover strip

Detailed information about how to produce and mount sliding-fit cover strips is contained in our "Mounting Instructions for the Cover Strip" RDEFI 82 070.

Size	Part numbers Expanding tool
25	1619-215-10
35	1619-315-30
45	1619-415-30
55	1619-515-30
65	1619-615-30
55/85	1810-592-30
65/100	1810-692-30
125	1810-391-30

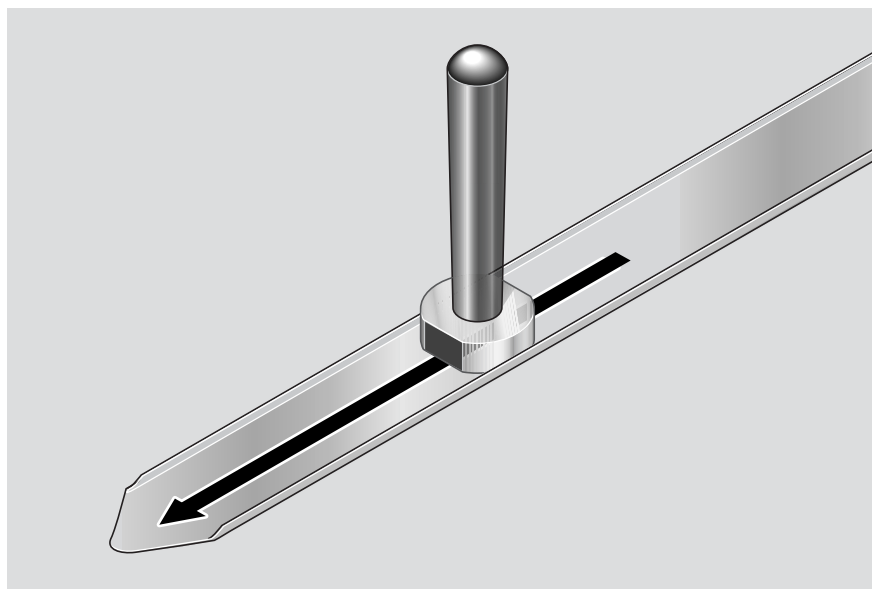

# Accessories for Guide Rails

## Protective caps, strip clamp

Rexroth recommends securing the cover strip with:

- protective caps
- screw and washer
- strip clamp (new)
- For other means of securing the cover strip, see our "Mounting Instructions for the Cover Strip" RDEFI 82 070.

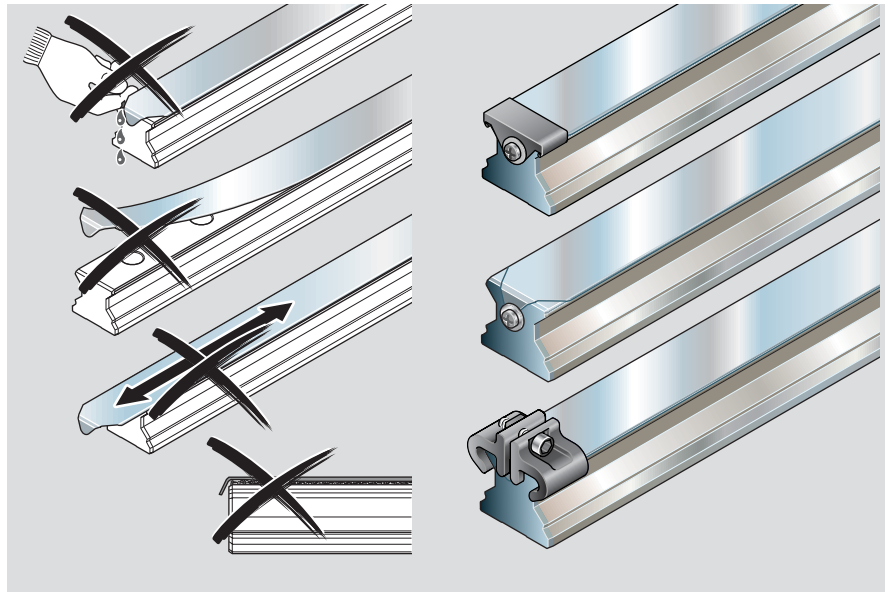

## Part numbers for protective caps

Size	Part numbers Protective caps		
	Single cap	Bulk pack / qty	Set with screws
25	1619-239-00	1619-239-01 / 1000	1619-239-20
35	1619-339-10	1619-339-01 / 1000	1619-339-30
45	1619-439-00	1619-439-01 / 700	1619-439-20
55	1619-539-00	1619-539-01 / 500	1619-539-20
65	1619-639-00	1619-639-01 / 300	1619-639-20

## Part numbers for screws and washers

Size	Part numbers	
	Screw	Washer
	1200 screws	1200 washers
25	8427-046-05	8448-026-01
35	8427-046-05	8448-024-01
45	8427-046-05	8448-024-01
55	8427-046-05	8448-027-01
65	8427-046-05	8448-027-01
55/85	8427-046-05	8448-027-01
65/100	8427-046-05	8448-027-01
125	8427-046-05	8448-027-01

## Part numbers for the strip clamp

Size	Part numbers Strip clamp	
	Bulk pack, 100 clamps	Set (2 clamps)
25	1619-239-60	1619-239-50
35	1619-339-60	1619-339-50
45	1619-439-60	1619-439-50
55	1619-539-60	1619-539-50
65	1619-639-60	1619-639-50

# Rexroth Roller Rail Systems

## Accessories for Guide Rails

### Plastic mounting hole plugs

Size	Part numbers	
	Single plug	Bulk pack qty <sup>1)</sup>
25	1605-200-80	5000
35	1605-300-80	2000
45	1605-400-90	1000
55	1605-500-90	500
65	1605-600-90	–

<sup>1)</sup> When ordering bulk packs, add the required quantity to the part number of the single plug.

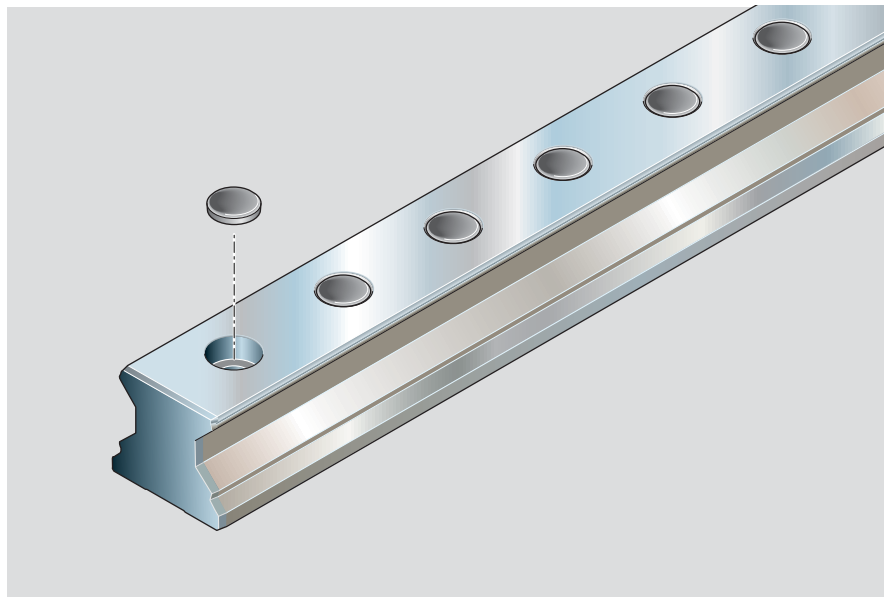

### Steel mounting hole plugs

Size	Part numbers	
	Single plug	
25	1606-200-75	
35	1606-300-75	
45	1606-400-75	
55	1606-500-75	
65	1606-600-75	

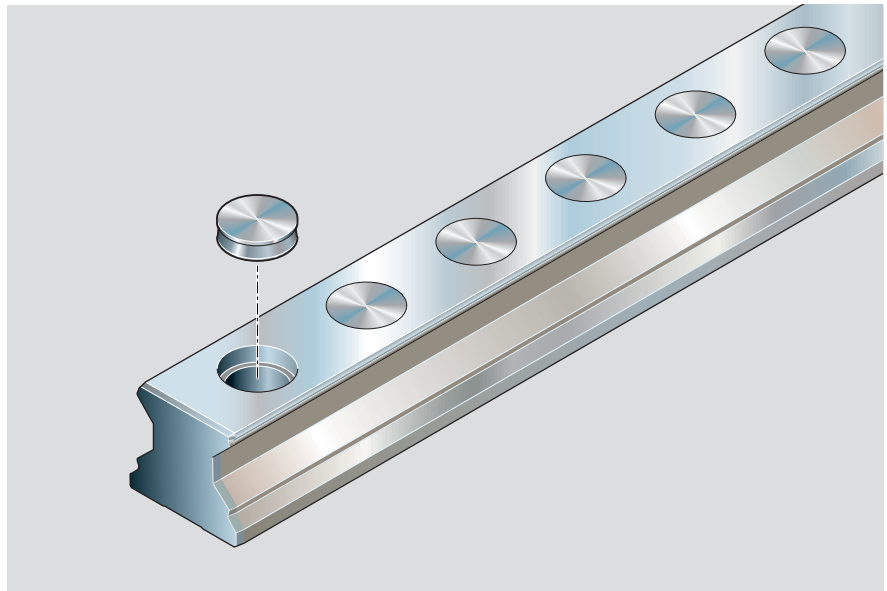

### Mounting tool for steel mounting hole plugs

#### two-piece

A mounting tool with mounting instructions is available for fitting steel mounting hole plugs.

Size	Part numbers	
	Two-piece mounting tool	
25	1619-210-20 <sup>1)</sup>	
35	1619-310-30	
45	1619-410-30	
55	1619-510-30	
65	1619-610-30	

<sup>1)</sup> One-piece tool, two-piece tool on request

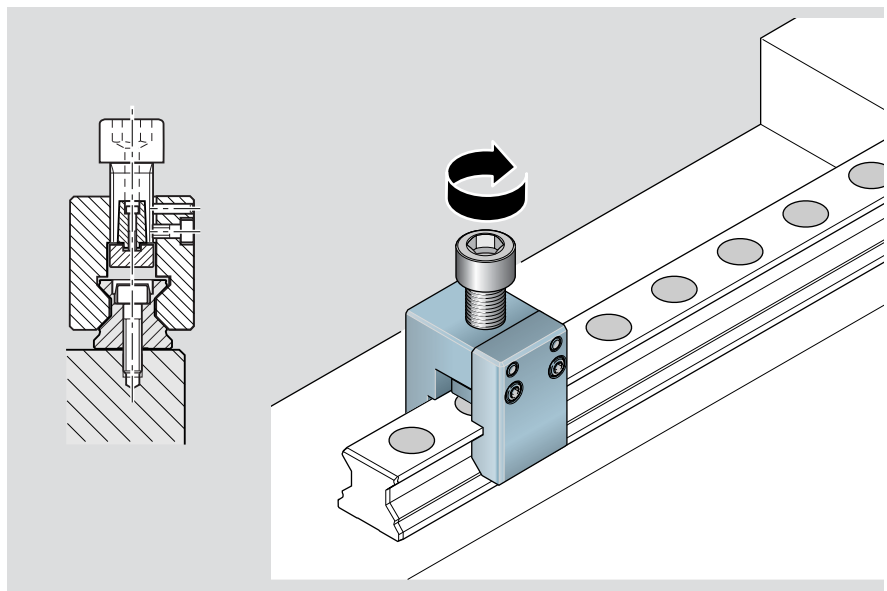

# General Accessories – Runner Blocks

## Tapered lube nipple

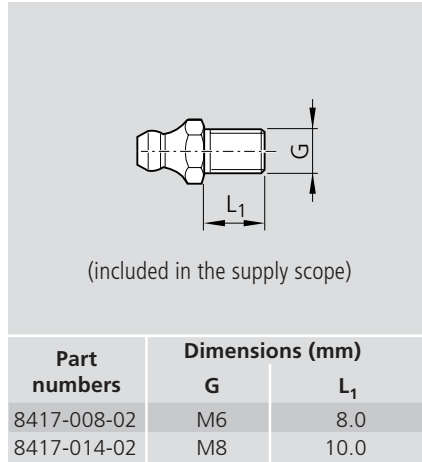
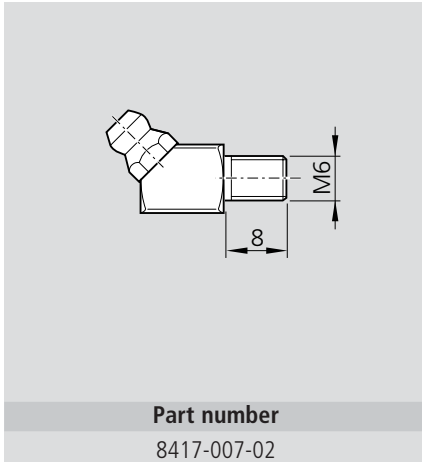

## Lube fittings

### Reducers

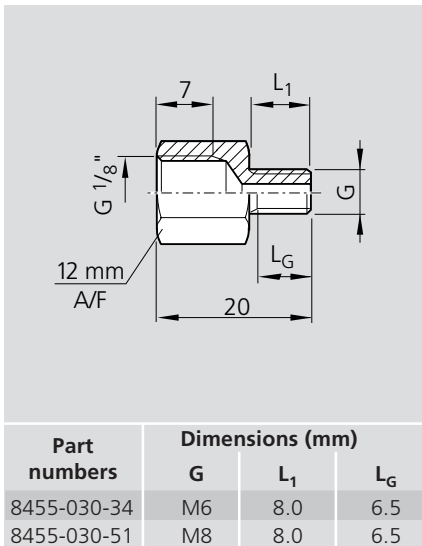

### Connectors

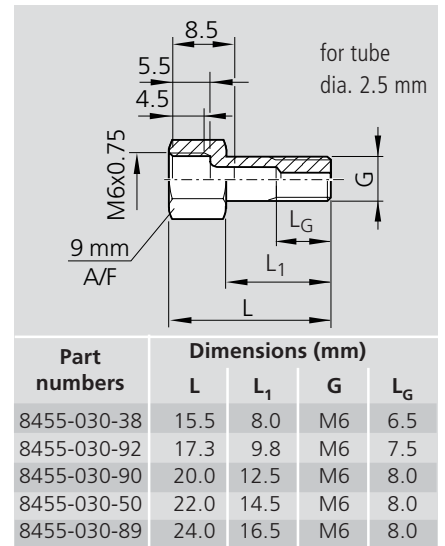
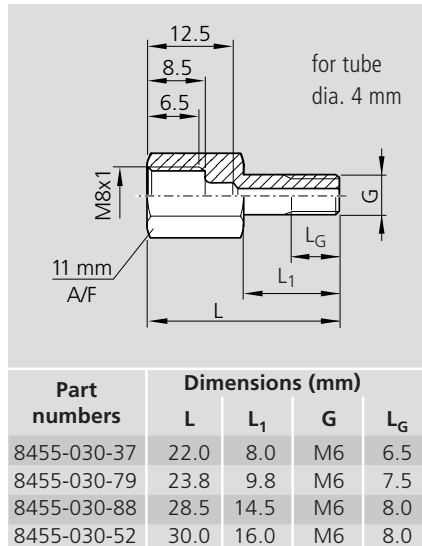

### Extension pieces

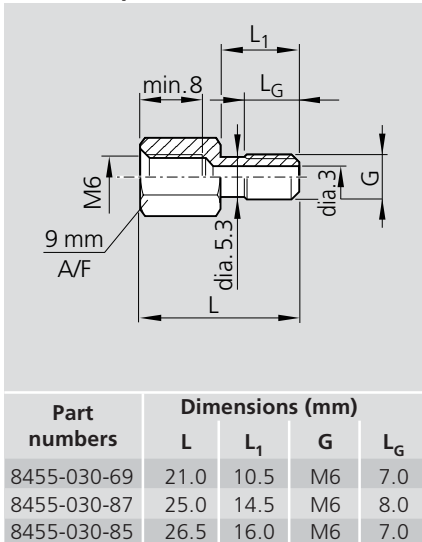

### Swivel fittings

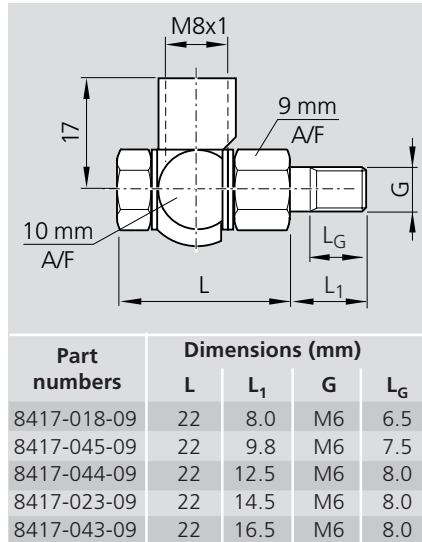

# Rexroth Roller Rail Systems

## General Accessories – Runner Blocks

### Tube connectors

Tube materials: copper, brass, PU, nylon

#### Straight connector

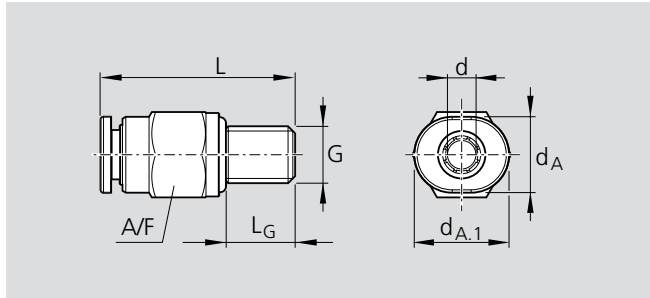

Part numbers	Dimensions (mm)						
	$d_A$	$d_{A.1}$	$d^{1)}$	L	A/F	G	$L_G$
8417-035-09	8	10	4	20.5	9	M6x1	8.0
8417-036-09	10	12	6	21.3	10	M6x1	8.0

<sup>1)</sup> Tube diameter

#### Angled socket connector, rotatable

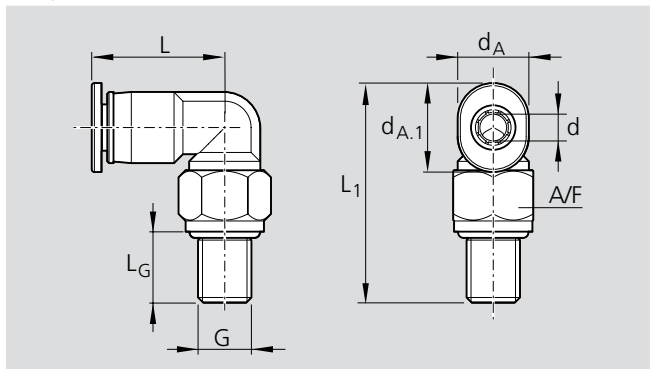

Part numbers	Dimensions (mm)							
	$d_A$	$d_{A.1}$	$d^{1)}$	L	$L_1$	A/F	G	$L_G$
8417-038-09	8	10	4	14.95	24.7	9	M6x1	8.0
8417-039-09	10	12	6	15.90	24.9	9	M6x1	8.0

<sup>1)</sup> Tube diameter

#### O-rings

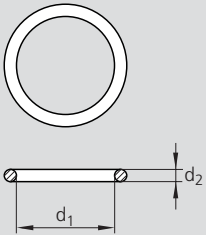

O-rings	
Part numbers	$d_1 \times d_2$ (mm)
8411-128-01	4 x 1.5
8411-108-01	5 x 1.5
8411-136-01	6 x 1
8411-004-01	6 x 2
8411-122-01	7 x 1.5
8411-008-01	8 x 2
8411-135-01	10 x 1.5
8411-018-01	12 x 1.5
8411-145-01	15 x 2.5

## General Accessories – Runner Blocks

### Mounting handle

as mounting aid for heavy duty runner blocks

Part number 1869-340-09

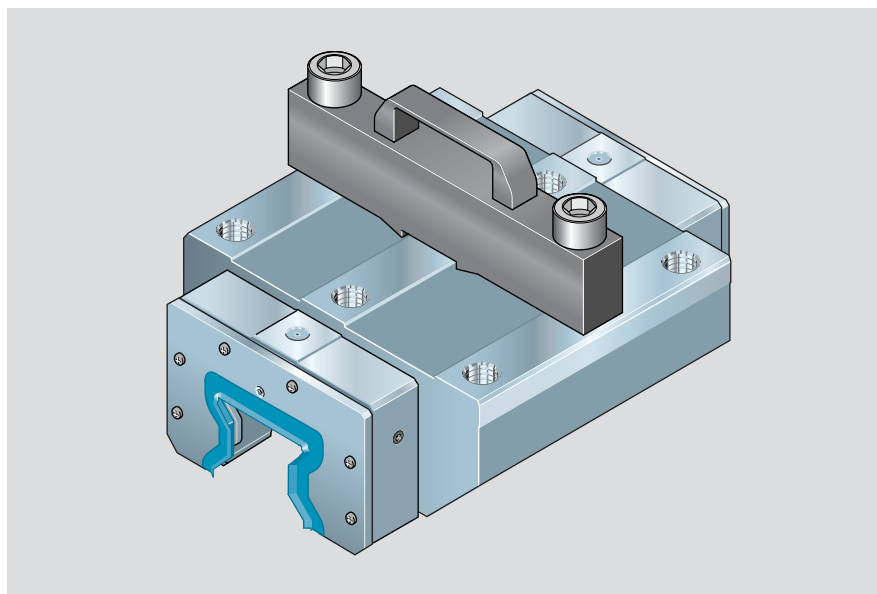

## General Accessories – Guide Rails

### Adjusting shafts

as mounting aid for composite guide rails

Especially when there is no reference edge.

Observe the Mounting Instructions for Roller Rail Systems.

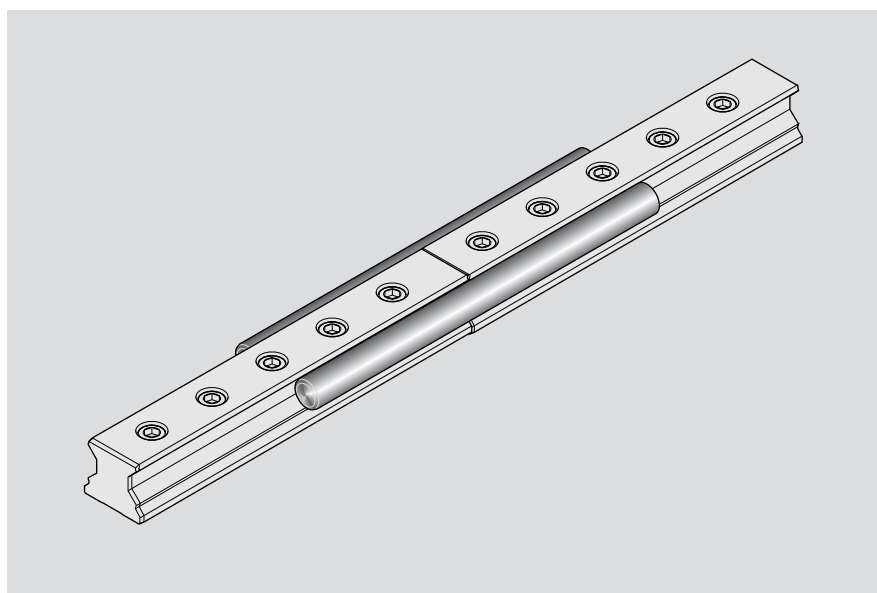

### Part numbers and dimensions

Always order two adjustment shafts for mounting.

Size	Part number Adjusting shaft (single)	Dimensions (mm)	
		Shaft dia.	Length
25	–	–	–
35	1810-390-01	20	160
45	1810-490-01	25	200
55 and 55/85	1810-590-01	30	250
65 and 65/100	–	–	–
125	1810-391-01	80	600

# Rexroth Roller Rail Systems

## General Accessories – Guide Rails

### Mounting runner block

as mounting aid for parallel alignment of the guide rails

#### Note

Hole D serves both as key hole and screw hole.

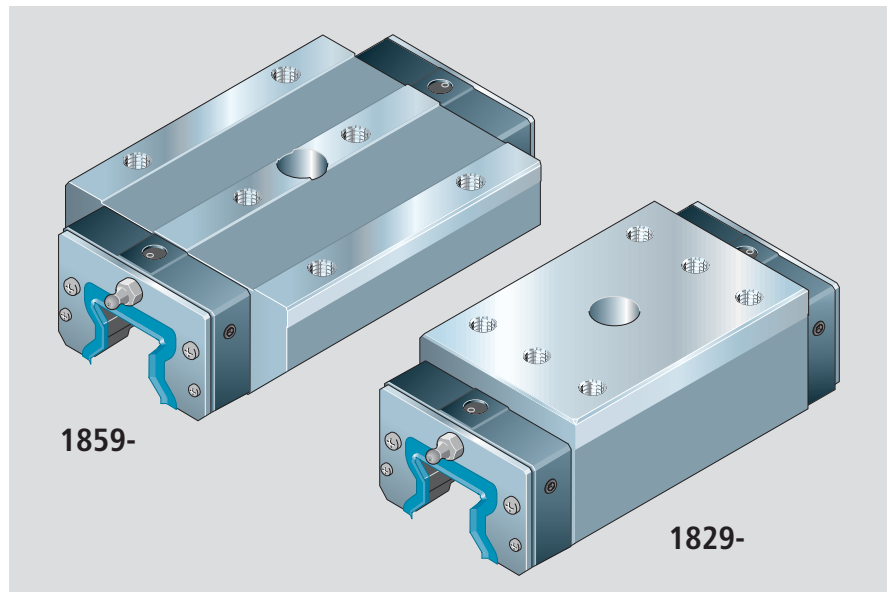

### Mounting runner block, standard width

Size	Part numbers, mounting runner block, standard width, long
	Preload 0.13 C
25	1859-220-19
35	1859-320-46
45	1859-420-76
55	1859-520-43
65	1859-620-29

### Mounting runner block, slimline

Size	Part numbers, mounting runner block, slimline, high, long
	Preload 0.13 C
25	1829-220-27
35	1829-320-39
45	1829-420-53
55	1829-520-14
65	1829-620-04

### Mounting instructions

The central hole D in the mounting runner block allows precise measurement of the relative rail position. The rail mounting screws can also be driven down through this hole.

Aligning the rails:

- Align and mount the first rail using a graduated straightedge.
- Set up a mounting bridge with dial gauge between the runner blocks.
- Move both runner blocks in parallel until hole D in the mounting runner block is positioned precisely above a mounting hole.
- Align the guide rail manually until the dial gauge shows the correct dimension.
- Then screw down the rail through hole D in the mounting runner block.

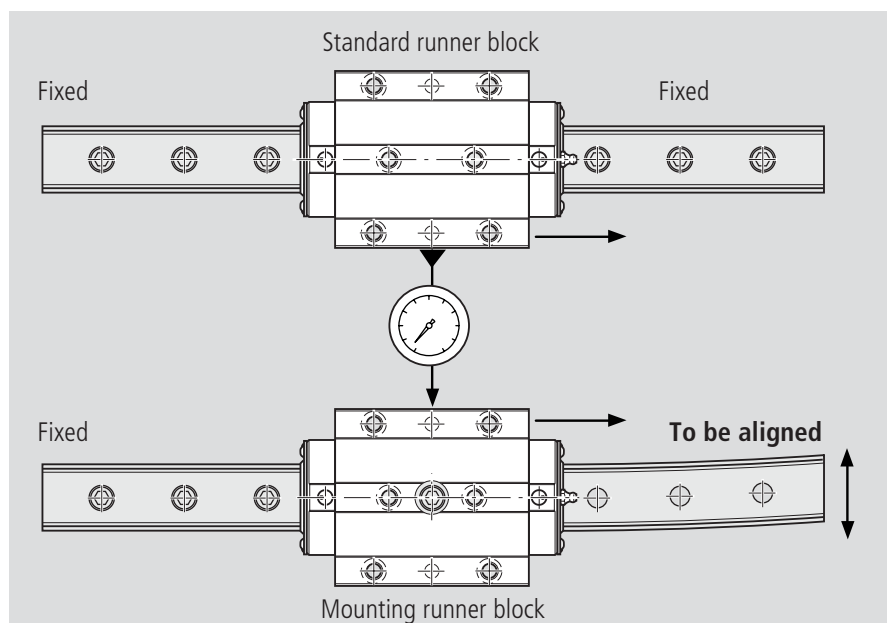



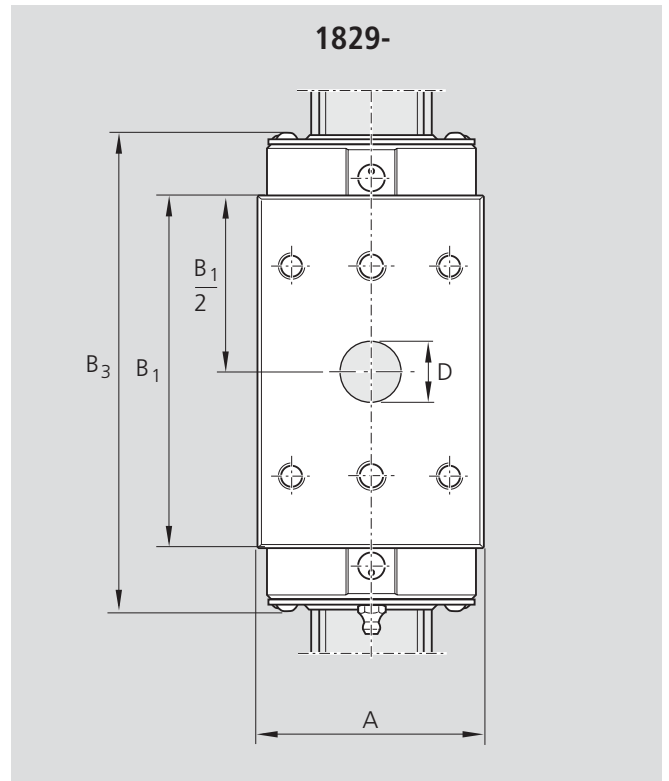
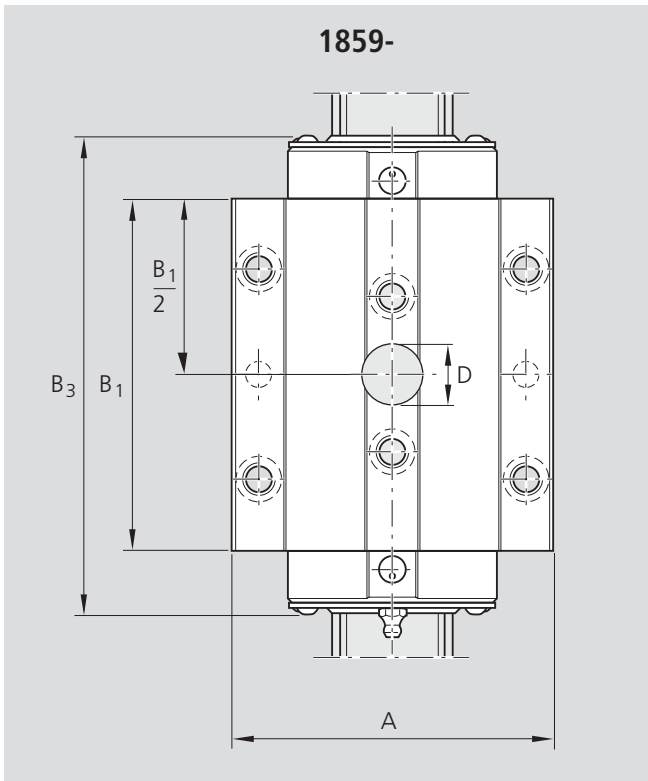

Dimensions 1859- (mm)				
Size	A	B <sub>1</sub>	B <sub>3</sub>	D
25 <sup>1)</sup>	70	81.5	115	19
35	100	103.6	145	25
45	120	134.0	183	27
55	140	162.1	216	27
65	170	194.0	264	30

Dimensions 1829- (mm)				
Size	A	B <sub>1</sub>	B <sub>3</sub>	D
25 <sup>1)</sup>	48	81.5	115	19
35 <sup>1)</sup>	70	103.6	145	25
45	86	134.0	183	27
55	100	162.1	216	27
65	126	194.0	264	30

<sup>1)</sup> In preparation

For all other dimensions, see runner block  
1853- (corresponds to 1859-) or 1824-  
(corresponds to 1829-)

# Rexroth Roller Rail Systems

## General Accessories – Guide Rails

### Wedge profile for lateral retention of the guide rails

- Material: steel
- Finish: black finished

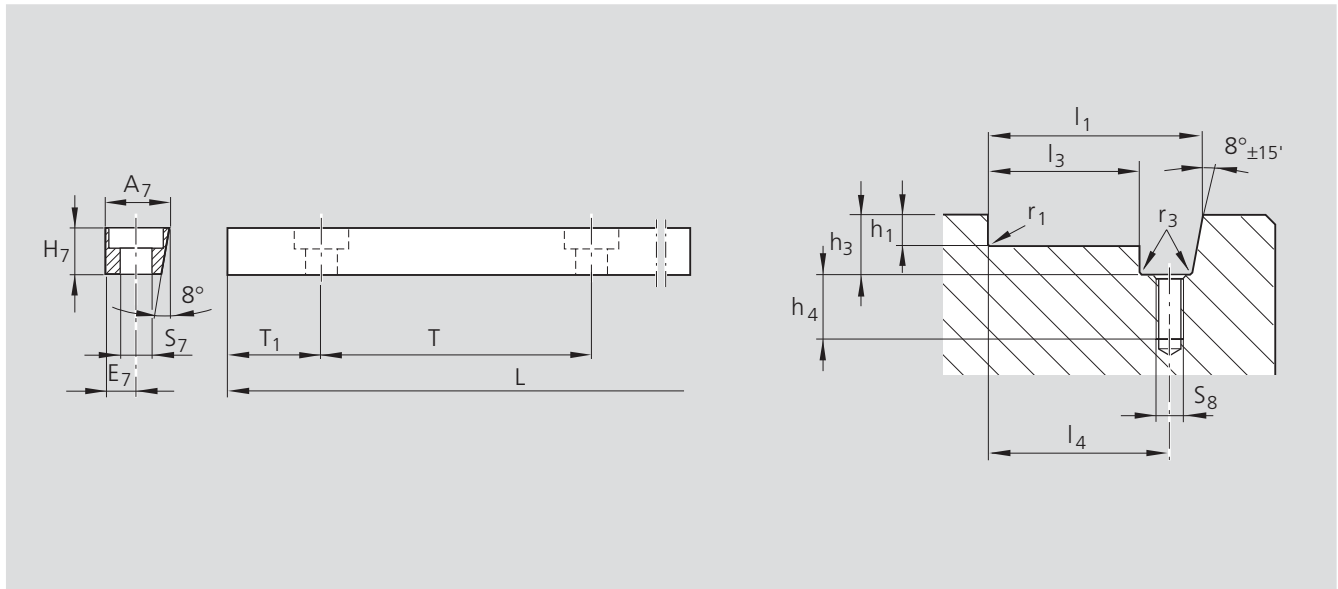
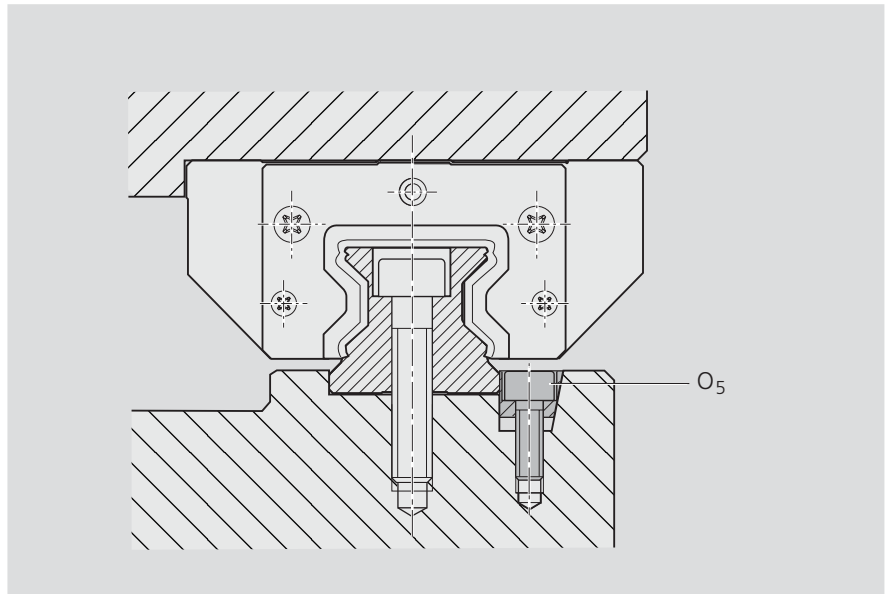

### Part numbers and dimensions

Size	Part numbers	Wedge profile Dimensions (mm)								Wedge profile groove Dimensions (mm)								
		A <sub>7</sub>	E <sub>7</sub>	H <sub>7</sub>	S <sub>7</sub>	T	T <sub>1</sub>	L	O <sub>5</sub> DIN 6912	h <sub>1</sub> -0.2	h <sub>3</sub> +1	h <sub>4</sub> +2	l <sub>1</sub> ±0.05	l <sub>3</sub> -0.1 -0.2	l <sub>4</sub> ±0.1	S <sub>8</sub>	r <sub>1</sub> max.	r <sub>3</sub> max.
<b>25</b>	1619-200-01	12	6	10	5.5	60	28.5	957	M5x20	4.5	12.5	15	35.1	23	29	M5	0.8	0.5
<b>35</b>										5.0	12.5	15	46.1	34	40	M5	0.8	0.5
<b>45</b>	1619-400-01	19	9	16	9.0	105	51.0	942	M8x25	7.0	19.0	16	64.1	45	54	M8	0.8	0.5
<b>55</b>										9.0	19.0	16	72.1	53	62	M8	1.2	0.5
<b>65</b>										9.0	19.0	16	82.1	63	72	M8	1.2	0.5
<b>125</b>	1810-391-02	47.5	23	30	17.5	120	57.0	954	M16x45	20.0	34.0	29	172.6	125	148	M16	1.8	1.0

# Rexroth Roller Rail Systems

## Spare Parts

### End seal

- Material: stainless spring steel to EN 10088 with plastic seal
- Finish: bright

### Mounting instructions:

Comes complete with mounting screws.  
Dispose of the old screws.

Detailed information is contained in our "Mounting Instructions for Roller Rail Systems" RDEFI 82 370.

Only for replacement on new runner block, if front lube unit damaged during mounting.

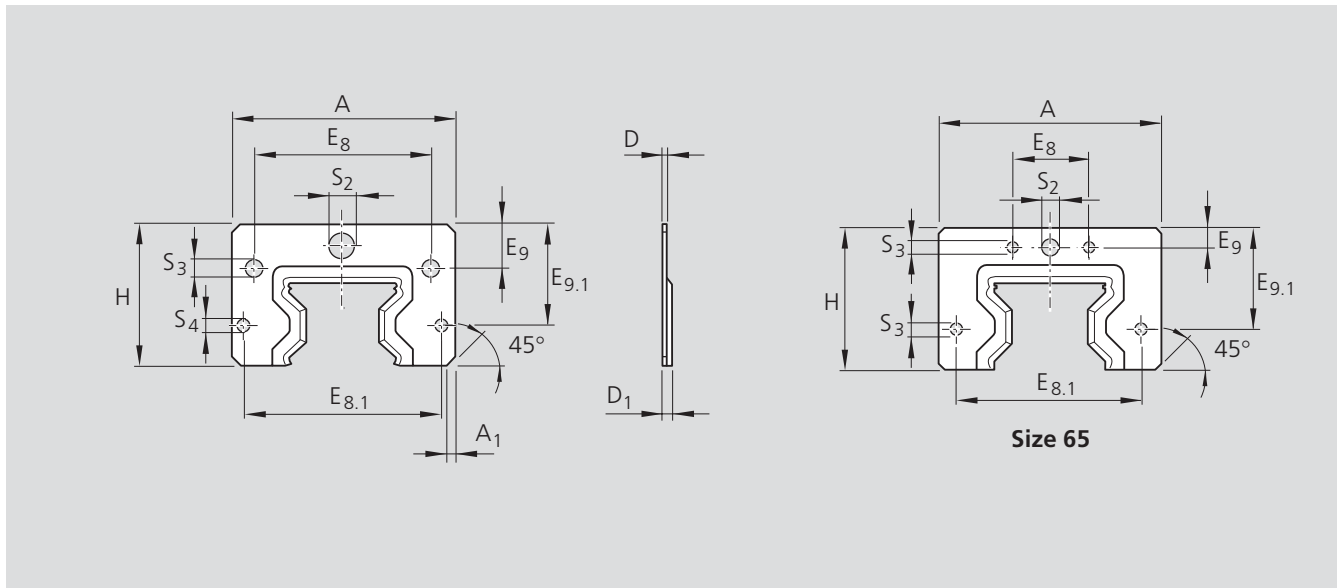
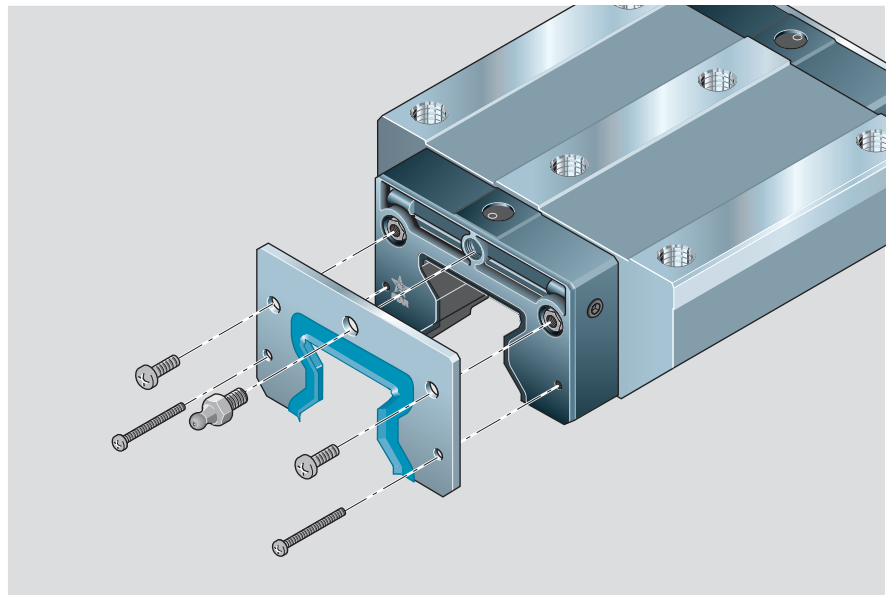

### Part numbers and dimensions

Size	Kit Part numbers	Dimensions (mm)											
		A	A <sub>1</sub>	H	E <sub>8</sub>	E <sub>8.1</sub>	E <sub>9</sub>	E <sub>9.1</sub>	dia. S <sub>2</sub>	dia. S <sub>3</sub>	dia. S <sub>4</sub>	D	D <sub>1</sub>
25	1810-210-00	44.0	1.2	28.5	33.4	40.2	7.9	20.7	7	4	3	1	2.6
35	1810-310-00	63.0	2.0	39.8	50.3	56.6	12.4	28.4	7	4	3	1	2.6
45	1810-410-00	77.0	2.0	49.8	62.9	69.6	16.0	35.8	7	5	4	2	4.0
55	1810-510-00	90.5	2.0	56.2	74.2	81.6	18.2	40.0	7	6	4	2	4.8
65	1810-610-00	119.0	3.0	74.5	35.0	106.0	8.3	54.0	7	5	5	2	5.0

# Rexroth Roller Rail Systems

## Spare Parts

For further information, see our "Mounting Instructions for Roller Rail Systems" RDEFI 82 370.

### Set of end caps with end seals

for replacement as part of system servicing

Size	Part numbers Set
25	1810-290-10
35	1810-390-10
45	1810-490-10
55	1810-590-10
65	1810-690-10

#### Mounting instructions:

Comes complete with mounting screws.  
Dispose of the old screws.

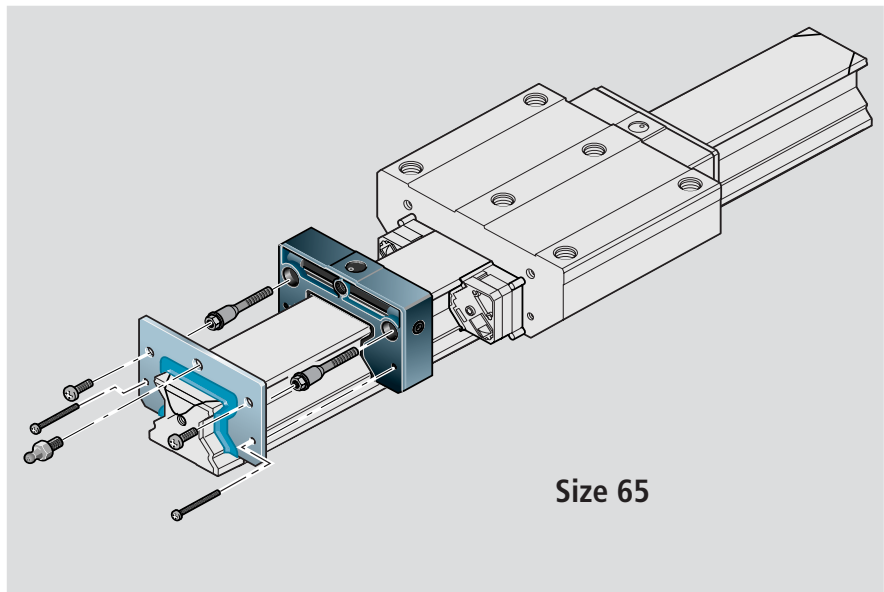

Size 65

### Set of aluminum end caps with end seals

Size	Part numbers Set
35	1810-390-60
45	1810-490-60
55	1810-590-60
65	1810-690-60
55/85	1810-592-60
65/100	1810-692-60
125	1810-391-60

#### Mounting instructions:

Comes complete with mounting screws.  
Dispose of the old screws.

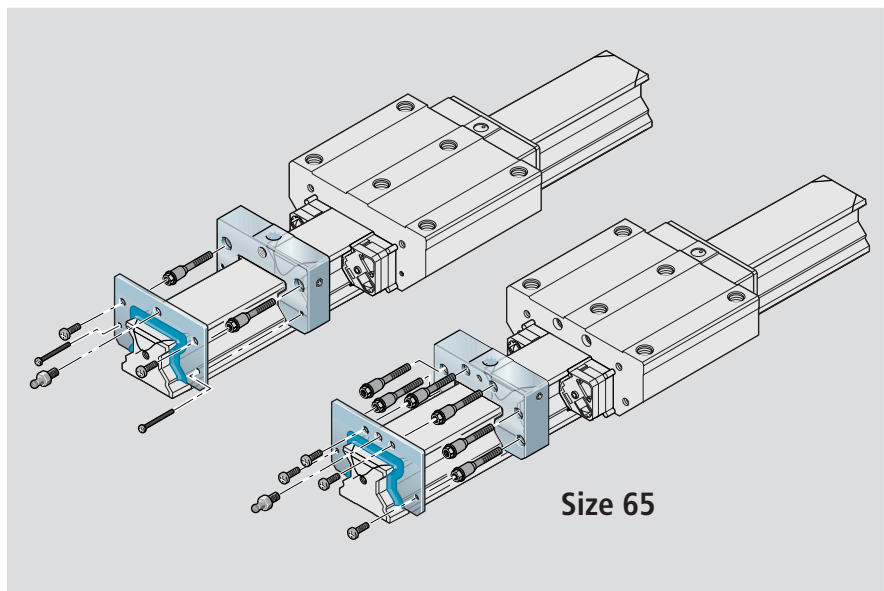

Size 65

### Transport and mounting arbor for runner blocks

– Material: plastic

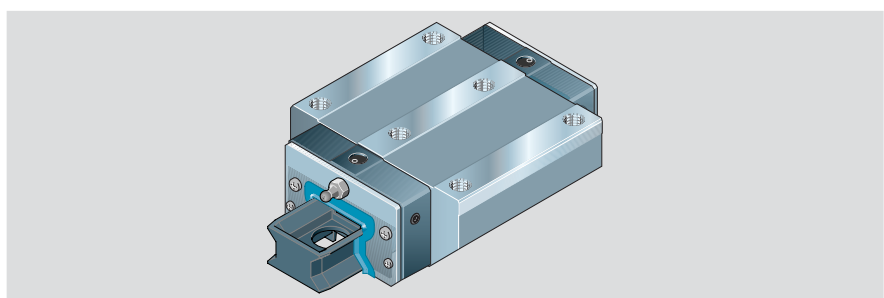

Size	Transport and mounting arbor	
	standard length	long
25	1851-200-91	1853-200-91
35	1851-300-91	1853-300-91
45	1851-400-91	1853-400-91
55	1851-500-91	1853-500-91
65	1851-600-81	1853-600-91
55/85	–	1871-500-81
65/100	–	1871-600-81
125	1861-300-81	1863-300-81

# Rexroth Roller Rail Systems

## Lubrication

### Lubrication

We have compiled a Lubrication Guide which provides basic know-how and criteria for the selection of lubricants.

Rexroth Roller Rail Systems are delivered filled with an anti-corrosion agent. Either oil or grease can be used as a lubricant.

Before start-up, make sure the system has sufficient initial lubrication.

### Dry axes and axes with minimal use of coolants

#### Grease lubricants

##### Lubrication using a grease gun or a dispensing system:

We recommend using a grease type to DIN 51 825 classified as follows:

- KP 2 K (grease of NLGI class 2 to DIN 51 818),
- KP 1 K or KP 0 K with lubricating properties matching the application (base oil, thickening agent, etc.)

For high loads  $> 0.2 \times C_{dyn}$ , we recommend a high quality grease lubricant (with synthetic base oil).

##### Lubrication via metering valves in a central lubrication system:

We recommend using liquid grease to DIN 51 825:

- Preferred type: KP 0 K (low-viscosity grease, consistency class NLGI 0 to DIN 51 818) with lubricating properties matching the application (base oil, thickening agent, etc.)
- KP 00 K or GP 00 K

Observe the instructions of grease and lubrication system manufacturers!

**⚠ Do not use greases containing solid lubricant particles (e.g. graphite or MoS<sub>2</sub>)!**

#### Short stroke

##### Stroke < 2 runner block lengths:

- Provide 2 lube ports per runner block and lubricate these!

##### Stroke < 0.5 runner block length:

- Provide 2 lube ports per runner block and lubricate these!
- Move the runner block over twice its length per lubricating cycle. If this is not possible, consult Rexroth.

Lubricant quantities as per table 1 (in-service lubrication).

Apply the specified lubricant quantity per lube port.

#### Initial lubrication of runner blocks

Initial lubrication requires a total of three times the partial quantity given in table 1:

1. Carefully press the grease gun to apply the first partial quantity of lubricant as per table 1 to the runner block.
2. Slide runner block back and forth over at least three times the block length for three full cycles. For size 125, slide runner block back and forth for three full cycles of at least 300 mm.
3. Repeat steps 1. and 2. twice more.
4. Check whether a film of lubricant is visible on the guide rail.

#### In-service lubrication of runner blocks

- Once the in-service lubrication interval as given in table 2 is reached, apply the lubricant quantity as stated in table 1.

If the equipment is to operate in an environment subject to dirt or vibration and shock loads, etc., we recommend shortening the in-service lubrication interval.

The smaller the load, the longer the intervals between in-service lubrication will be.

Size	Grease lubrication	
	Initial lubrication Partial qty (cm <sup>3</sup> )	In-service lubrication (cm <sup>3</sup> )
25	0.8 (x 3)	0.8
35	0.9 (x 3)	0.9
45	1.0 (x 3)	1.0
55	1.4 (x 3)	1.4
65	2.7 (x 3)	2.7
55/85	1.8 (x 3)	1.8
65/100	3.2 (x 3)	3.2
125	See fig. at right	Please consult us

Table 1

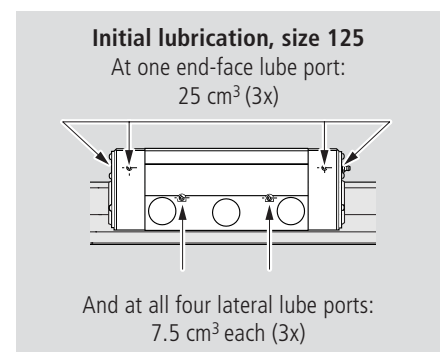

Size	Lubricating with grease NLGI ≥ 1 In-service lubrication intervals under normal operating conditions and loads ≤ 0.15 C <sub>dyn</sub> *	Lubricating with grease NLGI ≤ 0 In-service lubrication intervals under normal operating conditions and loads ≤ 0.15 C <sub>dyn</sub> *
	Travel (km)	Travel (km)
25	800	600
35	500	375
45	250	190
55	150	115
65	100	75
55/85	150	115
65/100	100	75
125	30	20

Table 2

\* For loads up to  $0.3 \times C_{dyn}$  the in-service lubrication interval reduces to a quarter of the specified travel.

# Rexroth Roller Rail Systems Lubrication

## Oil lubricants

### Notes

For normal operating conditions we recommend using a CLP oil to ISO VG 220 for both manual and central lubrication.

If the application involves low operating speeds or high loads ( $> 0.2 \times C_{dyn}$ ), we recommend using a synthetic oil lubricant with a viscosity of 220 to 460 mm<sup>2</sup>/s.

Observe the instructions of the oil and lubrication system manufacturers!

### Initial lubrication of runner blocks

Initial lubrication requires a total of twice the partial quantity given in table 3:

1. Apply the first partial quantity of lubricant as per table 3 to the runner block.
2. Slide runner block back and forth over at least twice the block length for three full cycles.
3. Repeat steps 1. and 2.
4. Check whether a film of lubricant is visible on the guide rail.

Size	Oil lubrication	
	Initial lubrication Partial qty (cm <sup>3</sup> )	In-service lubrication (cm <sup>3</sup> )
25	1.2 (2x)	1.2
35	1.3 (2x)	1.3
45	1.5 (2x)	1.5
55	2.0 (2x)	2.0
65	4.0 (2x)	4.0
55/85	2.7 (2x)	2.7
65/100	4.8 (2x)	4.8
125	38.0 (2x)	38.0

Table 3

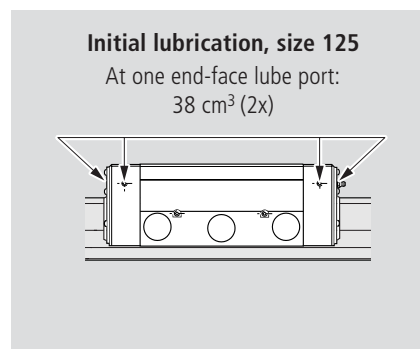

### In-service lubrication of runner blocks

- Once the in-service lubrication interval as given in table 4 is reached, apply the lubricant quantity as stated in table 3 in a single pulse.

The lubricant quantities for central oil lubrication via metering valves are given in tables 5, 6 and 7.

If the equipment is to operate in an environment subject to dirt, vibration, shock loads, etc., or where coolants are used, we recommend shortening the in-service lubrication interval.

The smaller the load, the longer the intervals between in-service lubrication will be.

Monitor the lubrication state during the initial cycles and adjust the in-service lubrication interval as required.

Size	In-service lubrication intervals under normal operating conditions and loads $\leq 0.15 C_{dyn}$ *
	Travel (km)
25	400
35	250
45	125
55	75
65	50
55/85	75
65/100	50
125	10

Table 4

\* For loads up to  $0.3 \times C_{dyn}$  the in-service lubrication interval reduces to a quarter of the specified travel.

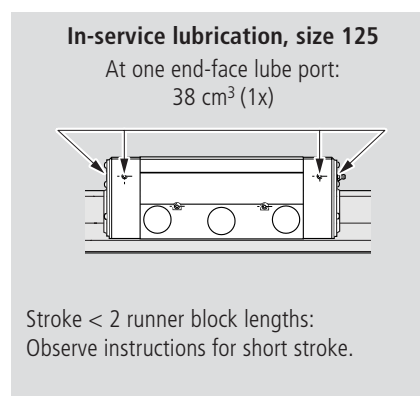

# Rexroth Roller Rail Systems

## Lubrication

### Normal stroke and short stroke

#### Normal stroke:

##### Stroke > 2 runner block lengths

- Provide 1 lube port per runner block.
- Orientations I, II and III: Apply oil quantity as per table 3 (in-service lubrication) in a **single** pulse.

If this is impossible for orientation III, please consult Rexroth.

#### Short stroke:

##### Stroke < 2 runner block lengths

- Provide 2 lube ports per runner block and lubricate both of these.
- Orientations III, IV and V: Apply oil quantity as per table 3 (in-service lubrication) in a **single** pulse.

If this is impossible for orientation III, please consult Rexroth.

#### Stroke < 0.5 runner block length:

- See “Stroke < 2 runner block lengths” plus the following:
- Move the runner block over at least twice its length per lubricating cycle. If this is not possible, provide for lubrication of the guide rail.
- Grease lubrication is preferred for this application case.

### Orientations

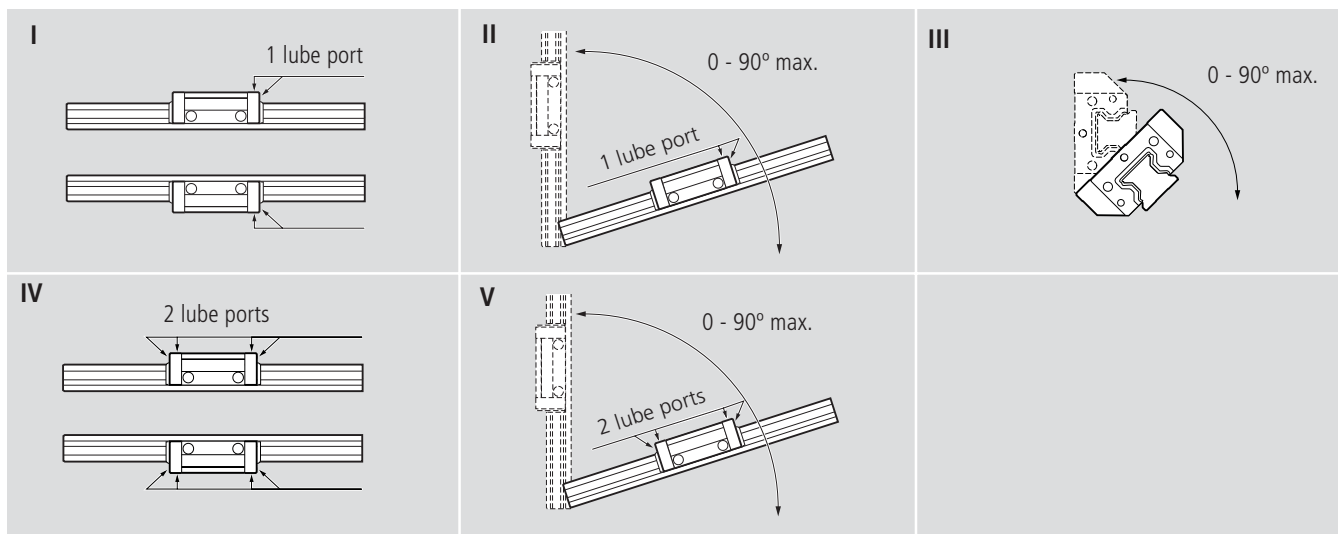

### Central oil lubrication

#### Orientations I, II, IV, V

#### Notes

Lubrication mode 1 as per table 5:

in-service lubrication interval as per table 4

Lubrication mode 2 as per table 5:

- For initial lubrication or lubrication after a prolonged standstill, apply oil in 2 to 5 consecutive pulses.
- Wherever possible, lubricate with the runner block in motion.
- Carry out cleaning cycles. See “Maintenance” section.

Size	Lubrication mode	Oil quantity per pulse (cm <sup>3</sup> )	Pulses per lubrication cycle	Pulses per hour
25	1	0.6	2 <sup>1)</sup>	–
	2	0.06	1	3 - 4 <sup>2)</sup>
35	1	0.6	2 <sup>1)</sup>	–
	2	0.1	1	3 - 4 <sup>2)</sup>
45	1	0.6	3 <sup>1)</sup>	–
	2	0.1	1	3 - 4 <sup>2)</sup>
55	1	0.6	4 <sup>1)</sup>	–
	2	0.16	1	3 - 4 <sup>2)</sup>
65	1	0.6	7 <sup>1)</sup>	–
	2	0.2	1	3 - 4 <sup>2)</sup>

Table 5

1) Interval between pulses: 20 secs max.

2) Irrespective of travel

### Special recommendation for runner blocks installed at an angle about the centerline, orientation III

Part numbers	Lubrication mode	Oil quantity per pulse and port (cm <sup>3</sup> )	Pulses per lubrication cycle	Pulses per hour
18...3...18	2	0.06	1	3 - 4 <sup>2)</sup>
18...4...18	2	0.06	1	3 - 4 <sup>2)</sup>
18...5...18	2	0.10	1	3 - 4 <sup>2)</sup>

Table 6

# Rexroth Roller Rail Systems

## Lubrication

### Wet axes with liberal use of coolants

#### Oil lubricants

Orientations I, II, IV, V

#### Notes

Lubrication mode 2 as per table 7:

- For initial lubrication or lubrication after a prolonged standstill, apply oil in 2 to 5 consecutive pulses.
- Wherever possible, lubricate with the runner block in motion.
- Carry out cleaning and lubrication cycles. See "Maintenance" section.

Size	Lubrication mode	Oil quantity per pulse (cm <sup>3</sup> )	Pulses per lubrication cycle	Pulses per hour
25	2	0.06	1	4 <sup>1)</sup>
35	2	0.10	1	4 <sup>1)</sup>
45	2	0.16	1	4 <sup>1)</sup>
55	2	0.20	1	4 <sup>1)</sup>
65	2	0.20	1	4 <sup>1)</sup>

Table 7

<sup>1)</sup> Irrespective of travel



# Rexroth Roller Rail Systems

## Maintenance

### Cleaning cycle

Dirt can settle and encrust on guide rails, especially when these are not enclosed.

To ensure that seals and cover strips retain their functionality, this dirt must be removed at regular intervals.

It is advisable to run the machine through at least one full cleaning cycle over the entire installed rail length every 8 hours.

Depending on the amount of spoiling and on the coolant used, more frequent cleaning may be required.

Before shutting down the machine, always run two cleaning cycles over the entire installed rail length, followed by at least two lubrication cycles over the entire installed rail length.

### Checking accessories

All accessories used for scraping or wiping the guide rails must be checked at regular intervals.

In environments with heavy soiling, it is advisable to replace all the parts in the soiled area.

We recommend checking the accessories at least once a year.

# Rexroth Roller Rail Systems

## Notes



Rexroth Star GmbH  
D-97419 Schweinfurt, Germany  
Member of  
Bosch Rexroth Group  
Telephone +49-9721-937-0  
Telefax +49-9721-937-275  
(general)  
Telefax +49-9721-937-250  
(direct)  
Internet [www.boschrexroth.com/brl](http://www.boschrexroth.com/brl)  
E-mail [info.brl@boschrexroth.de](mailto:info.brl@boschrexroth.de)

Great care has been taken during the compilation of this publication to ensure all the information contained is accurate. We accept no responsibility however for any damage resulting from incorrect or incomplete information contained.

For deliveries and other services in the course of commercial business, the general terms and conditions for supplies and services contained in the valid price lists and the confirmations of order apply.

As our products are constantly in the process of further development, they are subject to alteration without notice.

STAR, Ball Rail and  are trademarks registered for Rexroth Star GmbH, Germany.

Roller Rail is a trademark of Rexroth Star GmbH, Germany.

Reproduction of this document, even in extract form, is only permitted with our approval.