

Cartridge Program - Oil Control

The Drive & Control Company



INDEX

General Information	03
Mechanical Data	23
Solenoid Data	26
Pressure Control Valve	32
Special Valves	42
Check Valves	44
Counterbalance Valves	45
Flow Control Valves	59
Logic Elements	69
Directional Valves, Mechanically Operated	75
Shuttle Valves	78
Solenoid Valves	80
Coils	101
Manifolds	103
Cavities	116
Preferred Items	126
Cartridge Valves - RC X BROC	127

Hydraulic valves for mobile applications

RE 64 020-B1/08.05

General Information



What you need to know about these Operating Instructions

These Operating Instructions apply to Rexroth hydraulic valves for mobile applications and consist of the following three parts.

Part I General Information RE 64 020-B1

Part II Product-specific Instructions

Part III Technical Datasheet

If you do not have all three parts, please request the missing part from Bosch Rexroth AG.
Only if all the information contained in all parts of the three-part Operating Instructions is observed can safe operation of the Rexroth hydraulic valve be ensured.

Contents

1	General	4
1.1	Scope of application of these Operating Instructions	4
1.2	To assist your understanding of these Operating Instructions	4
1.3	Further important and applicable documents	4
2	Responsibilities	5
2.1	Liability and warranty	5
2.2	Responsibilities of the operator/user	5
3	Important basic safety instructions	6
3.1	Proper use	6
3.2	Improper use	7
3.3	Requirements for personnel, duty of care	7
3.4	Ancillary dangers and protective measures	9
3.5	Disposal	10
4	Pressure fluids	11
4.1	General information on pressure fluids	11
4.2	Malfunctions due to contamination of pressure fluid	11
4.3	Topping up / refilling	12
5	Storage and longer standstills	13
5.1	Storage conditions	13
5.2	Corrosion protection	13
5.3	Ageing during storage and longer standstills	13
6	Assembly and bringing into first use	14
6.1	Before bringing into first use	14
6.2	Bringing into first use, subsequent bringing into use	16
7	Maintenance	18
7.1	Definitions of terms	18
7.2	Safety during maintenance tasks	19
7.3	Inspection and servicing	20
7.4	Repair	20

1 General

1.1 Scope of application of these Operating Instructions



These Operating Instructions apply to Rexroth control and regulating valves for mobile control systems.

These Operating Instructions are intended for the use of the system manufacturer and the designer as well as the operator.

The designer can be a person that is responsible for the design of a hydraulic system in which Rexroth valves are used.

1.2 To assist your understanding of these Operating Instructions

Cross-references are printed in *italics*.

 DANGER	This symbol of danger indicates high risk, danger of loss of life or of serious injury.
 WARNING	This symbol of danger indicates medium risk, injury and serious damage to property.
 CAUTION	This symbol of danger indicates slight risk and possible damage.
Important	This symbol indicates additional information.

1.3 Further important and applicable documents

For system manufacturers and users, in addition to the Operating Instructions, the relevant installation drawing issued by Bosch Rexroth AG shall apply.

2 Responsibilities

2.1 Liability and warranty

Bosch Rexroth AG is not liable for damages that result from non-compliance with or disregard of this user's manual.

Any modification of the Rexroth valves beyond the extent described in these Operating Instructions shall render the warranty and, if applicable, any further concessions granted, null and void.

Bosch Rexroth AG shall only be liable if the scope of delivery was shown to be defective. Bosch Rexroth AG shall not be liable if a deficiency occurs that involves parts having been replaced by the customer with equivalent but not identical parts as specified by the manufacturer.

2.2 Responsibilities of the operator/user

Users and operators of the Rexroth valves are responsible for the proper use of these valves.

Users and operators must ensure that the Rexroth valves are stored, used, operated and maintained only in accordance with the proper use as defined in these Operating Instructions.

Any maintenance tasks specified in these Operating Instructions must be carried out at the specified intervals.



WARNING

Mineral-oil-based pressure fluid is hazardous to health and water; it may also be flammable.

It may only be used if the relevant safety datasheet from the manufacturer is available and all the measures stipulated therein have been implemented.

Important

The Operating Instructions supplied by Bosch Rexroth AG – in all its parts and with all other relevant applicable documents – contain safety-related information that must be included by the system manufacturer/user in the Operating Instructions to be written for the final product.

A wide range of dangers can arise from the combined actions of the Rexroth valve and the machine or system in which the valve is installed.

System manufacturers, users or operators must therefore ensure that the Rexroth valve is only installed if it is suitable, without restrictions, for the proposed application at the installation location.

3 Important basic safety instructions

3.1 Proper use

Rexroth valves have been designed and constructed for the control and regulation of energy and signals using a flow of oil. The safety components integrated into the Rexroth valves satisfy at least Safety Category 1 in accordance with EN 954-1.

However, only by carefully observing these Operating Instructions can accidents be prevented and problem-free operation of your Rexroth valve be guaranteed.

Use the Rexroth valve only as described in these Operating Instructions and if it is stored, installed, operated and maintained in accordance with the technical data, operating and ambient conditions as defined in these Operating Instructions. The limiting values given in *Part III, Technical Datasheet* must be observed.

Information on storage and longer standstills is given in *5 Storage and longer standstills*.

Rexroth valves may only be operated if they are in perfect technical condition.

The Rexroth valve must be operated only with the pressure fluids intended for the purpose specified in *Part III, Technical Datasheet*. Information on using the Rexroth valve with different pressure fluids is available on request.

The Rexroth valve must be used only for the purpose specified in *Part III, Technical Datasheet*. The connections, operating conditions and performance data defined in these Operating Instructions must not be changed.

Important

If you wish to use the Rexroth valve with connections, operating conditions and performance data or for purposes other than those defined by Bosch Rexroth AG in these Operating Instructions, you should contact Bosch Rexroth AG in advance. The Rexroth valve must not be used with connections, operating conditions and performance data or for purposes other than those defined in these Operating Instructions without the written agreement of Bosch Rexroth AG.

Rexroth valves may only be converted within the scope given in *Part II, Product-specific Instructions*.

During setting up or maintenance work, unless impractical, the safety devices fitted by Bosch Rexroth AG must be present, properly installed and in full working order. They must not be relocated, bypassed or rendered ineffective.

3.2 Improper use

Modifications and/or conversions of a Rexroth valve are only permissible within the scope given in *Part II, Product-specific Instructions*.

Tamperproof lead seals installed by Bosch Rexroth AG shall not be removed or damaged except when this is necessary in the course of maintenance tasks defined in the Operating Instructions.

Rexroth valves for which these Operating Instructions apply shall not be used in potentially explosive atmospheres. Special Rexroth valves are available that can be used in potentially explosive atmospheres.

Pressure control valves without a type examination in accordance with the EU Pressure Equipment Directive must not be used as safety valves in safety-related applications.

The nameplate must not be removed or painted over.

3.3 Requirements for personnel, duty of care

3.3.1 General requirements, qualifications

Rexroth valves must never be operated or maintained by persons under the influence of alcohol, drugs or other medication which affect one's ability to react.

Persons under the age of 18 who are currently receiving instruction or training or are working under supervision may not work on Rexroth valves.

This does not apply to young persons of 16 or over if

- working on Rexroth valves is necessary in order for them to accomplish their training objective
- their protection is guaranteed by the supervision of an experienced, competent person and they are allowed to use only tools, materials and protective gear that preclude the risk of injury.

Specialist personnel are those who, using their specialist training, knowledge and experience as well as familiarity with the relevant conditions, can recognise possible dangers and undertake the necessary measures to eliminate possible accidents.

3.3.2 Requirements for maintenance personnel

It may be necessary to carry out maintenance tasks on the Rexroth valve in order to keep it in proper working order. For details please refer to *Part II, Product-specific Instructions*.

Maintenance tasks include inspection, servicing and repair of hydraulic and electrical components. The personnel carrying out these various tasks must have certain minimum qualifications.

For inspections of the external parts of hydraulic components, the personnel must fulfil the following requirements:

- they must be instructed about the tasks,
- Specialist knowledge of hydraulics is not required.

For maintenance of the hydraulic components, the personnel must fulfil the following requirements:

- They have been instructed in the relevant activity.
- Specialist knowledge of hydraulics is required.

For maintenance of the Rexroth valves, the personnel must fulfil the following requirements:

- The personnel must be hydraulics experts instructed in the tasks as defined above.
- The personnel must be familiar with the function of the hydraulic system as a whole, from subsystems to their interaction with the function of the machine as a whole.
- The personnel must be able to read hydraulic circuit diagrams, interpret individual functions from their symbols and understand function diagrams.
- The personnel must possess knowledge of the function and construction of hydraulic elements in general and of the Rexroth valves to be maintained in particular.

See also *7.4 Repair*.

For work on the electrics, the following applies:

All work on electrical equipment may only be carried out by an authorised, qualified electrician, or by instructed persons under the guidance and supervision of an authorised qualified electrician, in accordance with the rules applicable to electrotechnical products.

For work on the software, the following applies:

Modifications of the software may only be carried out by bodies authorised to do so by Bosch Rexroth AG.

3.4 Ancillary dangers and protective measures

 DANGER		
Danger zone	Ancillary danger	Protective measure(s), safety instructions
Connections and pressure lines (pipes and hoses)	Risk of injury or loss of life from sprayed pressure fluid under high pressure during maintenance work.	Depressurise the hydraulic system before starting maintenance work. Relieve any accumulators of pressure. Rectify leaks immediately.
	There is a health hazard if escaping pressure fluid comes into contact with the skin. This is a particular risk if the tank is at a higher level during repair work	Tanks installed above the valve being repaired must be emptied before work is started.
Surfaces of components and pressure lines	Risk of burning due to high surface temperatures	Allow hydraulic parts to cool before commencing maintenance work. Wear protective clothing.
Electrical components	Electric shock	Work on electrical components only in the non-powered state. Switch electrical connections off before assembly and disassembly work starts. All tasks that require product components to be dismantled must be performed only within the scope given in <i>Part II, Product-specific Instructions</i> .
	Failure caused by excessive moisture entry following cleaning with a high-pressure cleaner	Shield the valve from the direct effect of high-pressure water jets.

Handling pressure fluid without protection is hazardous to health.

Please observe the manufacturer's safety instructions and the relevant safety datasheets for the pressure fluid that you are using.

Serious damage to health or death may result if pressure fluid enters the blood stream or is swallowed. Contact a physician immediately if pressure fluid has entered the blood stream or has been swallowed.

**CAUTION****Risk of environmental pollution**

Danger zone	Ancillary danger	Protective measure(s), safety instructions
Connections and pressure lines (pipes and hoses)	Water or ground pollution due to leakage	Use a collecting trough. Rectify leaks immediately.

Important

Also see *2.2 Responsibilities of the operator/user*.

3.5 Disposal

Completely empty valve and dispose as scrap metal.

Important

To completely empty means that the valve must be properly emptied so that no more pressure fluid can drip out.

The valve does not need to be cleaned when it is completely empty.

Collect residual pressure fluid and dispose of it in accordance with the instructions given in the safety datasheet of the pressure fluid.

Dispose of electronic products in accordance with the applicable regulations.

4 Pressure fluids

4.1 General information on pressure fluids

The effectiveness of pressure fluid diminishes as it ages (undergoes chemical changes). Acids and resinous residues form that may cause moving parts inside the valves to stick.

The following factors accelerate the ageing process:

- high temperatures
- oxygen in the pressure fluid
- air humidity
- water
- metallic catalysts
- high operating pressure
- contaminants.

Important

Observe the following rules of thumb:

At pressure fluid temperatures $> 70^{\circ}\text{C}$, the rate of ageing doubles for every 10°C .

Further information on mineral-oil-based pressure fluids, also concerning Rexroth valves, can be found in our publications *RE 90 220 Mineral-oil Based Pressure Fluids* and *RE 90 220-1 Hydraulic Fluids on Mineral Oil Basis for Axial Piston Units*.

4.2 Malfunctions due to contamination of pressure fluid

Contaminants of the pressure fluid lead to malfunctions, increased wear and a shorter service life of the hydraulic product. This can have negative effects on the safety and reliability of the hydraulic product.

Therefore the maintenance tasks specified in the Operating Instructions of the hydraulic system shall be carried out at regular intervals and the utmost cleanliness is required during work on the hydraulic product.

Contamination of the pressure fluid can be caused by:

- Wear during operation of the machine/system (metallic and non-metallic abrasion)
- Leaks of the hydraulic product
- Contaminants introduced during servicing/repair
- The use of dirty (unfiltered) pressure fluid when the pressure fluid is changed.

4.3 Topping up / refilling

When topping up / refilling your hydraulic system, make sure that you use pressure fluid of the same sort and type and from the same manufacturer.

If the fluid is heavily contaminated or prematurely aged, then the system, including the tank must be cleaned and flushed before refilling. New pressure fluid must always be filtered in accordance with the required cleanliness class, as it does not normally meet the required cleanliness class in the as-supplied state. Flush out lines and hoses before installation.

Use a filter unit to fill the pressure fluid tank. Ensure that the filter element is clean. Do not remove the filter strainers from filler necks or the filter element from filters before filling the pressure fluid tank.

Important

The fineness of the filter shall correspond to the cleanliness class required by the overall system and if possible be even finer. The filter unit used shall fulfil the requirements for functional safety and service life.

If possible, fill the pressure fluid tank via a filling coupling, if possible using a filter in the return line.

5 Storage and longer standstills

5.1 Storage conditions

Store the Rexroth valve only in a dry, dust-free atmosphere that is free of corrosive agents and vapours, has a low moisture content and no large variations in temperature.

5.2 Corrosion protection

Rexroth valves are tested with mineral oil in the factory. This oil protects sealed valves against internal corrosion.

Unpainted valves or those that only have a galvanic coating are not protected against corrosion.

Delays in bringing into use, long shipping and storage times or long periods of non-use can lead to rust formation in Rexroth valves. Additional corrosion protection measures must be implemented to prevent this.

5.3 Ageing during storage and longer standstills

Long storage times or long periods of non-use of Rexroth valves leads to damage of seals and plastic parts.

External seals of valves that have been stored for more than 12 months must be checked for damage before they are installed. They must be replaced, if necessary.

All externally acting seals must be replaced after a storage time or standstill period of 3 years. Seal sets can be ordered from Bosch Rexroth AG.

Every time the unit is brought into use, the valves must be checked that they are not leaking to the outside, see *6 Assembly and bringing into first use*. If there is a leakage, the seals must be replaced.

6 Assembly and bringing into first use



CAUTION

Risk of injury and damage

Wear safety gloves to avoid being injured by sharp edges.

Assembling and bringing into (first) use shall only be done by an instructed, authorised hydraulics expert who has the required specialist knowledge.

Pay attention to cleanliness:

- Do not use cleaning wool or cloths containing fibres for cleaning. Depending on the condition of the system or machine, cleaning with fibre-free cloths may be sufficient. Use suitable liquid cleaning agents to remove lubricants and other stronger contaminants. Make sure that cleaning agent does not get into the hydraulic system.
- Use only sealing elements specified in *Part III, Technical Datasheet*.

6.1 Before bringing into first use

1. Check the delivery for completeness and transport damage.
2. Check whether the seals are present for all connections and that they are in a perfect condition.
3. Check that the Operating Instructions for the Rexroth valve are present and complete. Contact us if the Operating Instructions are incomplete.
4. If the valve is to be painted prior to assembly, then
 - before painting, protect all hydraulic connections from being covered in paint by fully inserting plastic screw plugs
 - protect any fastening threads from being covered in paint by inserting a screw
 - carefully mask the flange surfaces of the valves as well as the subplates and end-plates before painting to prevent dirt and paint from entering
 - mask plastic plugs of the electrical connections and make sure not to damage the plugs in any way.

A removable foil has been applied to the nameplate in the factory to protect them during painting.

When removing the plastic screw plugs, ensure that paint splinters do not get into the valve.

5. Mount the Rexroth valve.
 - Use the intended seal for each hydraulic connection.
 - Mount and fit the pipes to the Rexroth valve so that they are free of strain.
 - Tighten the fastening bolts evenly with the specified tightening torque. Only fastening materials specified in the Operating Instructions are to be used.
6. Ensure that the interfaces of the system/machine and the installation conditions provide for safe operation of the Rexroth valve. If in doubt, consult the people responsible for the overall system / functional machine.
7. Based on the operating instructions for the system or machine in which the Rexroth valve is to be installed, check whether bringing the hydraulic system into use could lead to uncontrolled, dangerous movements. Where appropriate, take into account the hazard analysis / risk assessment for the system or machine.

8. Take the precautions appropriate to the anticipated dangers, e. g.:
 - Ensure that the cylinder piston rod can move out without danger.
 - Use a hoist or other lifting device to additionally secure lifted loads.
9. As part of bringing into (first) use, check whether the electric motors and valve solenoids can be switched manually using the electrical controls of the system/machine. If they cannot be switched manually or they can but with difficulty you must provide a remote control (e. g. test boxes for Rexroth proportional valves) for the internal function test of the hydraulic system.
10. Draw up a sequential program for bringing into (first) use and store it with the technical documentation as an appendix to the Operating Instructions.
11. Divide the functional circuit diagram into separate mini-circuits that can each be started up in succession.
12. Read the functional circuit diagram and seek clarification of any unclear text or diagrams. More information on the functioning of subassemblies is given in the *Technical Datasheet*.
13. Establish into which position valves are to be switched, or how valves are to be set.
14. Put up any necessary directional, prohibitive or informative signs and check whether the meaning of these signs is explained in the Operating Instructions.
15. Follow this sequence for bringing into (first) use
 - Pump circuit
 - Parts of the control system: e. g. pressure cut-off and switchover, open centre, pressure reduction, etc.

6.2 Bringing into first use, subsequent bringing into use

- Take suitable precautions when bringing into first use to maintain the required purity of the pressure fluid.
 - Make sure that the quality of the pressure fluid is not diminished by contaminants in the system.
 - Completely remove any oil residues left over from the factory test.
 - Remove any gummed oil which may have formed due to incorrect storage.
- Connect all connection lines in accordance with the installation instructions provided by the manufacturer of the connectors.



DANGER

Danger due to pressure fluid escaping with a high pressure.

Wear safety goggles and safety gloves!

Make sure that pipes and hoses are connected at all ports or that the ports are sealed with screw plugs.

Carry out a special check to make sure that the union nuts and flanges are correctly tightened at the pipe connections and flanges.

- Set the pressure and flow control valves, pump regulator, signalling elements such as pressure switches, limit switches and temperature regulators to the settings and values defined in the sequential program (see 6.1 *Before bringing into first use*).



DANGER

Dangers due to malfunctions

Do not change the settings of valves with a safety function, valves with a position switch or valves with preset electronics.

- Do not remove the lead seals. Damaged or removed lead seals indicate improper use of the hydraulic product.
- Bleed the hydraulics (valve, pump, motor, line, cylinder). Bleed the hydraulics lines to consumers or measuring points at the highest point, if possible. Before bringing into use, the valve must be filled with pressure fluid and the system in which the valve is installed must be completely bled.

Important

Details on bleeding can be found in the *Operating Instructions of the respective system*.

Important

Details on fine-tuning can be found in the *Operating Instructions of the respective system*.

- Check the operating temperature after the machine has been running continuously for several hours. Too high an operating temperature indicates that there are faults that need to be analysed and rectified.
- After bringing the machine into first use, have a sample of the pressure fluid analysed to ensure that it achieves the required cleanliness class. Change the pressure fluid if the required cleanliness class is not achieved. If the pressure fluid is not tested in the laboratory after bringing the machine into first use: Change the pressure fluid.

Important

Information on how to perform the function test and pressure test can be found in the *Operating Instructions of the respective system*.

7 Maintenance

7.1 Definitions of terms

The term "Maintenance" as defined in DIN 31051 encompasses all measures to maintain and restore the desired conditions and to determine and assess the actual condition of the technical devices of a system.

These measures are divided into the following categories:

- Inspection (determining the actual condition)
- Servicing (maintaining the desired condition)
- Repair (restoring the desired condition).

7.2 Safety during maintenance tasks



DANGER

Dangers due to reduced safety during repair work

Experience has shown that the number of accidents is higher during repair work than during normal operations. Therefore, in the interests of safety, please observe all the following safety instructions at all times.

- Regularly check any safety devices – if installed – for their correct functioning.
 - Perform all maintenance work properly, completely and within the stipulated periods and make a record of the work.
 - Cordon off the maintenance zone at a sufficient distance before commencing work.
 - Pay attention to cleanliness to avoid malfunctions caused by contamination.
 - Exercise extreme vigilance when operating the hydraulic product in maintenance mode, which may in certain circumstances necessitate the temporary removal of certain safety devices. Switch off the hydraulic system and secure it against being unintentionally switched on again.
 - The set values of safety valves shall not be altered by the user. Any readjustment shall be performed by authorised testing bodies only.
 - Wear safety goggles, safety gloves and safety shoes. Depressurise the hydraulic product, relieve the pressure in any pressure accumulators.
 - Allow pressure lines and sections of the system which have to be opened to cool down before commencing maintenance work.
 - Open with care any segments that have to remain under pressure.
 - Note that if check valves are located in the pressure lines above the pumps, the hydraulic system may still be under pressure even after it has been disconnected from the actual pressure supply. Advance all cylinders to their safe end position.
 - Lower all loads. Use an external support if it is not possible to lower a load. Never perform any maintenance work on raised units without external support.
 - Switch off all pumps.
 - Mechanically support vertical cylinders so that they cannot descend.
 - Only new, interchangeable and tested components, replacement parts and lubricants in original-equipment quality are approved for use/replacement.
 - For reasons of safety, the installation of untested components is strictly prohibited.
 - Make sure that all safety devices are properly installed and have undergone a function test before bringing the system (back) into use.
 - Remove all tools and materials needed for maintenance from the hydraulic product after the work has been completed.
-

7.3 Inspection and servicing

The objective of inspection and servicing is

- to maintain all system functions along with the initial parameters of the system
- to ensure continual availability of the system
- to detect weak points
- to ensure that the system attains the required service life.

We strongly recommend the use of an inspection and servicing book, in which all work specific to the system and the site, and all inspection and servicing intervals should be defined and documented.

Important

The product-specific inspection and servicing plan for the Rexroth valve can be found in *Part II, Product-specific Operating Instructions*.

7.4 Repair

All repairs of Rexroth valves must be carried out only by workshops authorised by Bosch Rexroth AG.

--	--	--

HYDRAULIC FLUID

General properties: it must have physical lubricating and chemical properties suitable for use in hydraulic systems such as, for example:

- MINERAL OIL BASED HYDRAULIC FLUIDS HL (DIN 51524 part 1)
- MINERAL OIL BASED HYDRAULIC FLUIDS HLP (DIN 51524 part 2).

For use of environmentally acceptable fluids (vegetable or polyglycol base) please consult BROC.

Viscosity class: according to ISO-DIN, it is expressed by the ISO-VG number which indicates the average kinematic viscosity at 40°C (104°F) – mm²/s or centistokes –cSt-

VISCOSITY CLASS	KINEMATIC VISCOSITY - (cSt)		
	MAX at 0°C (32°F)	MED at 40°C (104°F)	MIN at 100°C (212°F)
ISO VG 10	90	10	2.4
ISO VG 22	300	22	4.1
ISO VG 32	420	32	5
ISO VG 46	780	46	6.1
ISO VG 68	1400	68	7.8
ISO VG 100	2560	100	9.9

Test conditions: the main performance curves and specifications shown in this catalogue are obtained using mineral based fluid ISO VG 46, with a cleanliness class of 17/14 - 18/14 ISO 4406 (8-9 NAS 1638), at a temperature of 30/40°C (86/104°F). More detailed technical characteristics are available at BROC.

Fluid temperature range: the valves are designed for fluids at a temperature between -30°C and +100°C (-22°F and +212°F). For temperatures outside this range, consult BROC.

Internal leakage: most BROC valves have a leak proof seat design, but there are different families of valves each providing a different level of sealing depending on the type and number of the poppets; the leakage features of each valve type must be selected in order to suit the application.

The table **A** (pg. A-PD3) shows the AVERAGE LEAKAGE for various valve families; the readings are achieved in the specified test conditions, and are measured in cm³/min or drops/min.

The ratio between them is:

$$1 \text{ cm}^3/\text{min} (0.06 \text{ in}^3/\text{min}) = 15\div 20 \text{ drops}/\text{min}.$$

For pressure relief valves the leakage is indicated at re-seating conditions, identified as X% of pressure relief setting.

CLEANLINESS (see table **B**, pg. A-PD3)

General information: the cause of malfunctions in hydraulic systems and components is often found to be excessive fluid contamination. The hard contaminant particles in the fluid wear the hydraulic components and prevent the poppets from re-seating, with consequent internal leakage and system inefficiency. For the correct operation of BROC valves it is necessary to ensure a fluid cleanliness class at least 19/15 ISO-4406, or 10÷11 NAS-1638, unless otherwise specified in the relevant technical sheet.

Filtration ratio (β_x): characteristic of each type of filter, it's the ratio between the number of particles before and after the filter with diameter larger than X micron.

Absolute filtration rating (ISO 4572): the diameter X of the largest particles with β_x ≥ 75.

Contamination class ISO 4406: expressed by two numbers respectively representing the number of particles larger than 5 μm and larger than 15 μm contained in 1 ml of fluid.

Contamination class NAS 1638: expressed by one number representing the number of particles of different size ranges contained in 100 ml of fluid.

--	--	--

CHART OF SEALING PROPERTIES



HYDRAULIC FUNCTION	VALVE TYPE (see product index)	FLOW gpm (l/min)	MAX. PRESSURE psi (bar)	OPERATION TYPE	AVERAGE LEAKAGE
PRESSURE RELIEF 	Direct acting poppet type (leak proof seat design)	1 - 8 (3 - 30)	5000 (350)	CONTINUOUS	5-10 drops/min at 80% of standard pressure setting (Z=20-35)
	Direct acting differential type (leak proof seat design)	11 - 93 (40 - 350)	5000 (350)	INTERMITTENT	(max 40 drops/min)
	Direct acting poppet type	5 - 53 (20 - 200)	5000 (350)	CONTINUOUS	5-10 cm ³ /min (0.31-0.61 in ³ /min) at 80% of standard pressure setting (Z=20-35)
	Pilot controlled spool type	40 (150)	6000 (420)	CONTINUOUS	100 cm ³ /min (6.1 in ³ /min) at 90% of standard pressure setting
CHECK VALVE 	Poppet type (leak proof seat design)	8 - 26 (30 - 100)	5000 (350)	CONTINUOUS	0-5 drops/min (max 20 drops/min)
	Ball type (leak proof seat design)	16 (60)	5000 (350)	INTERMITTENT	
PILOT ASSISTED COUNTERBALANCE 		8 - 85 (30 - 320)	5000 (350)	CONTINUOUS	5-10 drops/min at 80% of pressure setting (max 40 drops/min)

Table A

OIL CONTROL FILTRATION RECOMMENDATIONS

TYPE OF SYSTEM TYPE OF VALVE	NOMINAL FILTRATION micron	ABSOLUTE FILTRATION RATING ISO 4572 ($\hat{a} \times \geq 75$)	CONTAMINATION CLASS ACCORDING TO	
			ISO 4406	NAS 1638
Systems/components operating at HIGH PRESSURE > 250 bar (3600 psi) HIGH DUTY CYCLE APPLICATIONS Systems/components with LOW dirt tolerance	10	X = 10...12	17 / 14	8
Systems/components operating at MEDIUM HIGH PRESSURE Systems/components moderately dirt tolerance	15	X = 12...15	18 / 14	9
Systems/components operating at LOW PRESSURE < 100 bar (1500 psi) LOW DUTY CYCLE APPLICATIONS Systems/components with GOOD dirt tolerance	25	X = 15...25	19 / 15	10 - 11

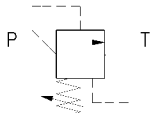
Table B

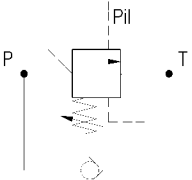
--	--	--

PRESSURE SETTING: BROC valves are supplied pre-set at the standard pressure setting shown by the relevant catalog sheet. Whenever the application requires a re-adjustment, please ensure that the limits of the indicated pressure range are never exceeded.

SEALING OF VALVE ADJUSTERS: plastic sealing caps are available for most cartridge valves. The cartridges can be purchased Factory sealed.

INSTALLATION OF CARTRIDGE VALVES:

Procedure to be followed for correct installation of the cartridge valves in their cavities:

- ensure that seals and back-up rings are flawless and correctly installed;
- check that both the cartridge and the cavity are clean, without contamination;
- dip the cartridge in clean oil;
- insert the cartridge into the cavity and screw it in by hand, until you begin to compress the top o-ring
- tighten with a calibrated torque wrench up to the specifications shown in the catalogue.

STORAGE OF NEW VALVES:

the valves shall not be exposed to direct sun light nor to sources of heat or ozone (like electric motors running), and should be stored in their original, protective wrapping at a temperature between -20°C and +50°C (-4°F and +122°F).

TECHNICAL DATA CONTINUOUS DUTY COILS - ED 100%

WORKING DUTY

DIN VDE 0580

The working duty ED of a coil is the ratio between energized time t_i and full cycle time t_c where $t_c = t_i + t_r$ and $t_r =$ de-energized time.

$$ED = (t_i / t_c) * 100 \%$$

ALL COILS ARE RATED FOR ED = 100 % PROVIDED THAT TEMPERATURE LIMIT OF THEIR INSULATION CLASS IS NOT EXCEEDED.

PROTECTION

DIN 40050 Part 9 - EN 60529

Protection class is designated by the letter IP followed by two digits: the first indicates protection against penetration of foreign solid bodies, the second against penetration of water. Protection class doesn't apply to explosion risks or to conditions such as moisture, corrosive agents, mildew etc.

IP65 MEANS WATER PROTECTION AGAINST:

- LOW PRESSURE JETS

Water at 43.5 psi (0.3 bar) pressure sprayed from a distance of 8.2 - 9.8 ft (2.5 - 3 m) from every direction. Coils CANNOT BE PLUNGED INTO WATER OR REMAIN UNDER WATER.

IP67 MEANS WATER PROTECTION AGAINST:

- 30 MINUTES IMMERSION AT 3.3 ft (1 m) DEPTH

IP69K MEANS WATER PROTECTION AGAINST:

- HIGH PRESSURE AND TEMPERATURE JETS

Water at 1160 - 1450 psi (80-100 bar) pressure and 167 - 185°F (75-85°C) temperature sprayed from a distance of 3.9 - 5.9 in (100 - 150 mm) from every direction.

PROTECTION THERMAL SHOCK DUNK TEST

This test, well known and commonly applied in the construction, agricultural and mobile equipment markets, includes several steps :

- 1) Coil is continuously energized for 1 hour at nominal voltage (ambient temperature 77°F (25°C)) or heated for 2 hours in oven at 221°F (105°C) (coil not energized)
- 2) Coil is immediately immersed in water at 68 - 77°F (20 - 25°C) for 30 minutes (minimum depth 11.8 in (300 mm))
- 3) Coil, when still wet, is tested for moisture ingress and dielectric breakdown with the "Hypot test". Using an instrument for testing dielectric strength, 500 VDC is supplied between winding and external surface of the coil and current leakage is measured. Current leakage must not exceed 100 micro-amps
- 4) Complete cycle is repeated for 5 times minimum on a sample of 10 coils minimum

All coils with DIN 43650 connector correctly mounted have IP65 protection.

S8-356, S7 and S5 coils with integrated Deutsch DT04-2P connector have IP69K protection and have passed the thermal shock dunk test.

INLET VOLTAGE

To obtain correct operation and long life of coils it is necessary that operating voltage fluctuations do not exceed $\pm 10 \%$ of nominal voltage.

HEAT INSULATION

DIN VDE 0580

All COILS

COMPLETE COIL	CLASS	H	365°F (180°C)
Copper wire			392°F (200°C)

These are the maximum allowable absolute temperatures $T = T_A + \Delta T$ where $T_A =$ ambient temperature and $\Delta T =$ temperature rise due to operation.

For example, if $T_A = 104^\circ\text{F}$ (40°C) we obtain $\Delta T_{\text{max}} = 239^\circ\text{F}$ (115°C) if we have to comply with the limit of 311°F (155°C) and $\Delta T_{\text{max}} = 284^\circ\text{F}$ (140°C) if we have to comply with the limit of 365°F (180°C).

The temperature rise ΔT is calculated from resistance at ambient temperature and resistance at stabilized temperature, measured according to DIN VDE 0580:

- coil is mounted on a standard cartridge valve size 06 inserted in a standard steel manifold on a wooden surface.
- coil is kept energized for 1 hour at nominal voltage, with ambient temperature $T_A = 68 - 77^\circ\text{F}$ ($20-25^\circ\text{C}$) and natural ventilation.

CLASS H COILS ARE NOT RATED FOR CONTINUOUS DUTY ED = 100 % IF AMBIENT TEMPERATURE EXCEEDS THE VALUE $T_x = 365 (180) - \Delta T$ °F (°C) IN ANY CASE FREE HEAT EXCHANGE AND NATURAL VENTILATION ARE NECESSARY FOR THE CORRECT OPERATION OF COILS.

EXTERNAL TEMPERATURE of coils is not directly related with ΔT . After few minutes of continuous energization temperatures up to $176-212^\circ\text{F}$ ($80-100^\circ\text{C}$) can be reached, so care should be taken to avoid accidental contact of people with hot surfaces.

AC SERVICE

All OIL CONTROL's solenoid valves are designed to operate only with DC power supply. All windings are DC.

AC service is possible using DIN 43650 connectors with rectifier (see page 1.71.010).



SCREW-OUT KNOB STYLE

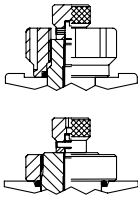

AVAILABLE ON FOLLOWING MODELS:

- 2 way 2 position pilot operated normally closed series 8A / 8I
- 2 way 2 position direct acting poppet style normally closed series 8I
- 2 way 2 position direct acting double lock normally open series 8I
- 3 way 2 position spool style series 8I / 7I
- 4 way 2 position spool style series 8I / 7I

OPERATION

To operate manual override, screw out the knob turning it counterclockwise.
 To return to normal valve operation, turn the knob clockwise.

SCREW-IN STYLE

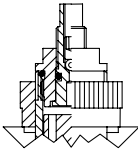

AVAILABLE ON FOLLOWING MODELS:

- Proportional valves series 5A

OPERATION

To operate manual override, screw in the pin turning it clockwise with wrench.
 To return to normal valve operation, turn the bolt counterclockwise.

PUSH STYLE

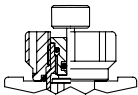

AVAILABLE ON FOLLOWING MODELS:

- 2 way 2 position pilot operated normally open series 8A / 8I
- 2 way 2 position direct acting poppet style normally open series 8I
- 2 way 2 position direct acting double lock normally closed series 8I

OPERATION

To operate manual override, push and hold override button.
 To return to normal valve operation, simply release the button.

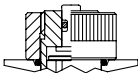

AVAILABLE ON FOLLOWING MODELS:

- 2 way 2 position direct acting double lock normally closed series 7A
- 3 way 2 position direct acting poppet style series 7A

OPERATION

To operate manual override, push and hold override button with tool.
 To return to normal valve operation, simply release the button.

PUSH AND TWIST STYLE

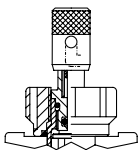

AVAILABLE ON FOLLOWING MODELS:

- 2 way 2 position pilot operated normally open series 8A / 8I
- 2 way 2 position direct acting poppet style normally open series 8I
- 2 way 2 position direct acting double lock normally closed series 8I

OPERATION

To operate manual override button, turn clockwise and release.
 To return to normal valve operation, push override button, turn counterclockwise and release.

PUSH AND PULL STYLE

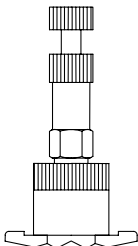

AVAILABLE ON FOLLOWING MODELS:

- 4 way 3 position spool style series 8A / 7I

OPERATION

To operate manual override, push to override S2 coil or pull to override S1 coil and hold override button.
 To return to normal valve operation, simply release the button.



PULL STYLE
CABLE OPERATED **HAND OPERATED**

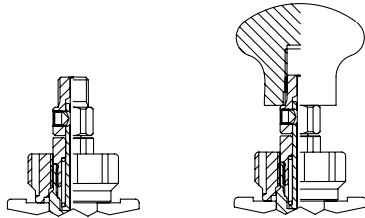

AVAILABLE ON FOLLOWING MODELS:

- 2 way 2 position pilot operated normally closed series 8A size 06

OPERATION

To operate manual override, pull and hold the knob. This override is not detented. Force required to operate is approximately 11.2 lbs (50 N).

This override can also be remote operated by a cable fixed to the M8 thread. In this case the spring may not provide enough force to overcome internal cable friction and the user must provide an external means of returning the cable.

SAFETY
PUSH STYLE

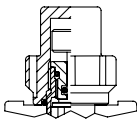

AVAILABLE ON FOLLOWING MODELS:

- 2 way 2 position pilot operated normally open series 8A / 8I
- 2 way 2 position direct acting poppet style normally open series 8I
- 2 way 2 position direct acting double lock normally closed series 8I

OPERATION

To operate manual override, screw out the knob protection after removing wire-locking and push and hold override button.

To return to normal valve operation, simply release the button.

SAFETY
PUSH AND TWIST STYLE

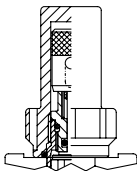

AVAILABLE ON FOLLOWING MODELS:

- 2 way 2 position pilot operated normally open series 8A / 8I
- 2 way 2 position direct acting poppet style normally open series 8I
- 2 way 2 position direct acting double lock normally closed series 8I

OPERATION

To operate manual override, screw out the knob protection after removing wire-locking and turn clockwise and release override button.

To return to normal valve operation, push override button, turn counterclockwise and release.

SAFETY
SCREW-IN STYLE

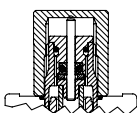

AVAILABLE ON FOLLOWING MODELS:

- 2 way 2 position pilot operated normally open series 8I
- 2 way 2 position direct acting poppet style normally open series 8I
- 2 way 2 position direct acting double lock normally closed series 8I

OPERATION

Safety manual override has been designed to avoid accidental operation of the emergency device.

Manual override can be operated only screwing out the knob, removing the coil and screwing the knob completely in again.

To return to normal valve operation it is necessary to turn out the knob and mount the coil again.



HYDRAULIC FLUID

GENERAL PROPERTIES

Hydraulic fluid must have physical, lubricating and chemical properties suitable for use in hydraulic systems such as, for example

MINERAL BASED HYDRAULIC OILS HL DIN 51524 Part 1
 MINERAL BASED HYDRAULIC OILS HLP DIN 51524 Part 2

VISCOSITY CLASS ISO 3448 - DIN 51519

ISO viscosity class is expressed by ISO VG followed by one number representing the medium kinematic viscosity at 104°F 40°C in mm²/s or centiStokes cSt

VISCOSITY CLASS	KINEMATIC VISCOSITY		
	Maximum at 32°F (0°C)	Medium at 104°F (40°C)	Minimum at 212°F (100°C)
ISO VG 10	90	10	2.4
ISO VG 22	300	22	4.1
ISO VG 32	420	32	5.0
ISO VG 46	780	46	6.1
ISO VG 68	1400	68	7.8
ISO VG 100	2560	100	9.9

FUNCTIONAL TESTING - TEMPERATURES - INTERNAL LEAKAGE

FUNCTIONAL TESTING

All performance curves in this catalogue are obtained using mineral based hydraulic oil with 46 cSt viscosity at 104°F (40°C) (ISO VG 46 viscosity class).

All valves go through functional testing at these conditions before shipment. Our test stands ensure 10 micron ABSOLUTE FILTRATION.

All performance curves represent the average of real values measured on tested valves. For this reason a tolerance of ± 15-29 psi (1-2 bar) for pressure drop and ± 20-30 ms for response time has to be considered normal and acceptable.

The electrical parameters and the response times of the ON-OFF solenoid valves are measured using 24 V DC coils at stabilized temperature and nominal voltage. Tests on proportional valves are performed using 12 V DC coils.

FLUID TEMPERATURE RANGE

-22°F (-30°C) to +212°F (+100°C)

AMBIENT TEMPERATURE RANGE

NON SOLENOID VALVES -22°F (-30°C) to +212°F (+100°C)
 SOLENOID VALVES SEE COIL PAGES
 Please consult us for different temperature ranges.

INTERNAL LEAKAGE - POPPET VALVES

MAXIMUM ALLOWABLE INTERNAL LEAKAGE of all poppet valves cannot exceed 0.06 in³/min (1 cm³/min) (15-20 drops/min) at the maximum working pressure with 46 cSt oil viscosity. Actual leakage is expected, on average, to be less than 10 drops/min and anyway tends to decrease after few seconds.

SEALS

O - RINGS

Acryl - Nitrile Butadiene Rubber NBR (BUNA-N) standard for temperatures between -22°F (-30°C) and +212°F (+100°C).
 FLUOROCARBON FPM (Viton) and other compounds are available on request.

BACKUP RINGS

LUBRIFLON - PTFE

SEAL KITS

SEAL KITS include ALL EXTERNAL SEALS. Internal seals of cartridge valves are not included, since the customer is not allowed to disassemble cartridge valves.

ORDERING CODE:

CARTRIDGE VALVES Substitute OD with KD
 VALVES IN STANDARD MANIFOLD Same as cartridge KIT
 VALVES IN EMERGENCY MANIFOLD Substitute OE with KE

EXAMPLES:

VALVE CODE: OD.15.32.18.18.00
 OS.15.32.18.18.02
 SEAL KIT CODE: KD.15.32.18.18.00
 VALVE CODE: OE.15.05.18.37.02
 SEAL KIT CODE: KE.15.05.18.37.02



CARTRIDGE INSTALLATION

It is recommended to follow these steps:

- Inspect the cartridge to ensure that no external contaminant is present.
- Check that O-ring and back-up rings are intact and correctly positioned. The O-ring should be towards the higher pressure port if only one back-up ring is present or between double back-up rings if both ports receive high pressure.
- Inspect cavity for burrs or other machining irregularities which could damage seals during installation.
- Dip the cartridge in clean oil.
- Screw the cartridge in BY HAND until the O-ring is met, then tighten to the torque specified in the cartridge catalogue page. Do not exceed maximum torque: overtightening may cause valve failure.

IMPORTANT: Continuous high frequency vibrations especially if combined with pulsating pressure, may cause cartridge unscrewing and consequent O-ring extrusion. Please consult our Technical Department.

COIL INSTALLATION

COIL WITH O-RING SEATS (S7 - S5)

It is recommended to follow these steps:

- Insert 1st O-Ring (see drawing)
- Insert coil
- Insert 2nd O-Ring (see drawing)
- Tighten BY HAND coil retaining nut to the torque specified in the cartridge catalogue page.

Example:

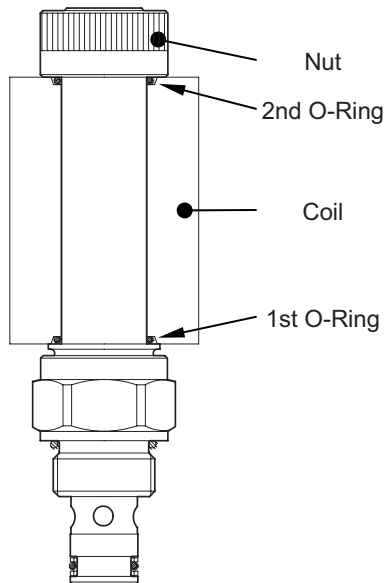

COIL WITHOUT O-RING SEATS (S8-356)

It is recommended to follow these steps:

- Insert 1st O-Ring (see drawing)
- Insert coil
- Tighten BY HAND coil retaining nut to the torque specified in the cartridge catalogue page. The 2nd O-Ring is fixed inside the nut.

Example:

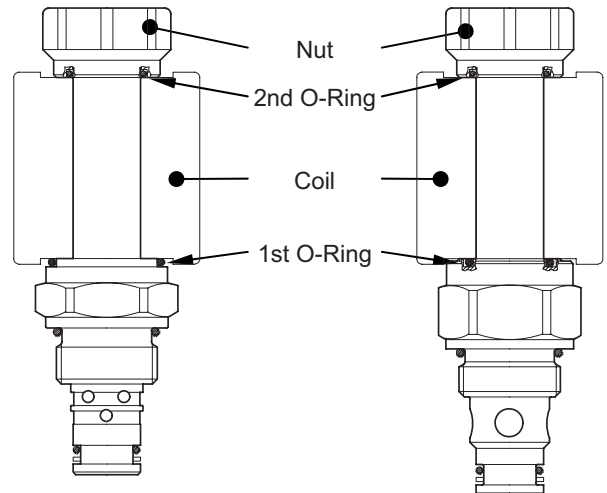

IMPORTANT: O-rings are the only protection against water infiltration between tube and coil, which may lead in short time to coil failure. The proper mounting of both O-rings is therefore necessary to ensure normal life of coils when operating in presence of water, ice, moisture etc. Oil Control cannot guarantee any IP protection degree if both O-rings are not properly mounted on coils.



GENERAL INFORMATION

Manufacturers and users of hydraulic equipment admit that contamination is the most likely cause of malfunction or failure in hydraulic systems and reduces security and reliability of components and systems. Metal particles flowing throughout the circuit scratch moving surfaces so that contamination level, if not controlled, increases very rapidly.

It is strongly recommended to maintain contamination level at least at nominal values shown below, choosing adequate filtration products.

FILTRATION RATIO BETAx

It's the ratio between the number of particles before and after the filter with diameter larger than X micron.

ABSOLUTE FILTRATION RATING ISO 4572

It's the diameter X of the largest particle with $BETAx \geq 75$.

CONTAMINATION CLASS ISO 4406:1999

It's expressed by 3 scale numbers representing respectively: the number of particles equal to or larger than 4 μm (c); the number of particles equal to or larger than 6 μm (c); the number of particles equal to or larger than 14 μm (c), contained in 0.034 oz (1 ml) of fluid.

CONTAMINATION CLASS NAS 1638

It's expressed by one scale numbers representing the number of particles of different size ranges contained in 3.4 oz (100 ml) of fluid.

TYPE OF SYSTEM	MINIMUM REQUIRED	FILTRATION RECOMMENDATIONS FOR EXTENDED PRODUCT LIFE		
		NOMINAL FILTRATION (μm)	ABSOLUTE FILTRATION RATING ISO 4572 $BETAx \geq 75$	CONTAMINATION ACCORDING TO
				ISO 4406:1999
PROPORTIONAL VALVES	6	X = 6...10	18 / 16 / 13	7
Systems/components operating at HIGH PRESSURE > 3600 psi (250 bar) HIGH CYCLE APPLICATIONS	10	X = 10...12	19 / 17 / 14	8
Systems/components with LOW dirt tolerance				
Systems/components operating at MEDIUM PRESSURE up to 3600 psi (250 bar)	15	X = 12...15	20 / 18 / 15	9
Systems/components operating at LOW PRESSURE < 1450 psi (100 bar) LOW CYCLE APPLICATIONS	25	X = 15...25	21 / 19 / 16	10
Systems/components with GOOD dirt tolerance.				

Pressure Control Valves	
VSBN-08A	
VSBN-10A	
VSBG-10A	
VSNG-10A	
VSPN-10A	
VSPY-10A	
VSPY-10A	
VSPY-10A	
VRPP-10A	

**RELIEF, DIRECT ACTING GUIDED POPPET TYPE
COMMON CAVITY**



VSBN-08A

SIZE 08

04.11.49 - X - 56 - Z

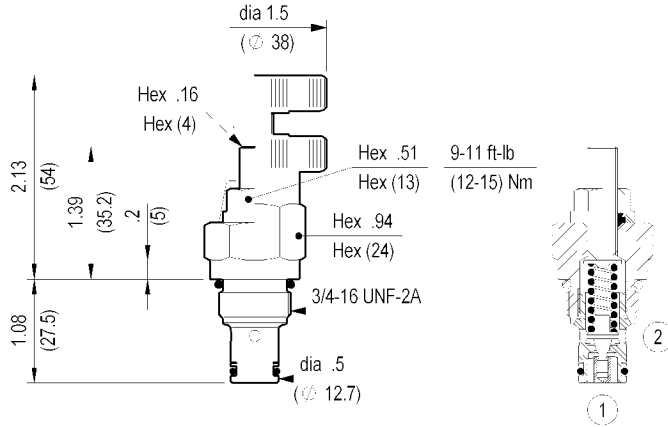

Inches
(mm)

Flow is blocked from 1 to 2 until pressure increases to meet the selected valve setting, lifting the poppet from its seat and allowing relief flow through port 2 to tank. Pressure at port 2 is additive to the relief setting of the valve. The unique Oil Control poppet design provides enhanced stability at all flows and pressures.

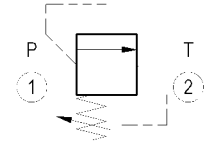

TECHNICAL DATA

Max. pressure: 5000 psi (350 bar)

Max. flow: 5 gpm (20 l/min)

Cavity : CA-08A-2N (see page CT.A.001.U)

Line bodies : see page MN1.A...

External seal kit : see page A11.011

Installation torque : 25-30 ft-lb (34-41 Nm)

Weight: 0.309 lbs (0.140 Kg)

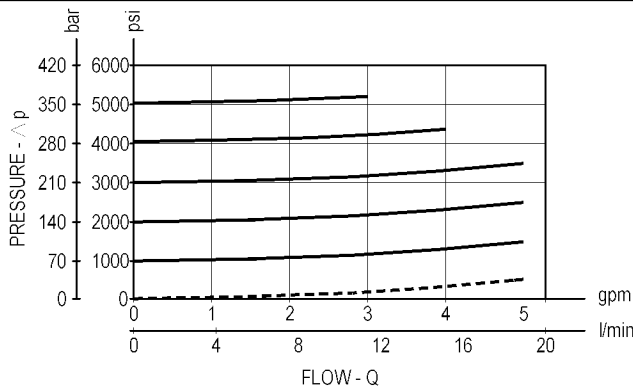

X ADJUSTMENTS

03 Leakproof hex. socket screw



04 Handknob and locknut



73 O-Ring seal on adjust screw



Z

SPRINGS

		Adj. press. range psi (bar)	Press. increase psi / turn (bar/turn)	Standard setting psi (bar) (Q=5 l/min)
X = 03	05	145-1000 (10-70)	375 (26)	725 (50)
	10	500-2000 (35-140)	725 (50)	1450 (100)
	20	1500-3000 (105-210)	1145 (79)	2900 (200)
	35	2500-5000 (175-350)	2465 (170)	5000 (350)
X = 04	35	500-5000 (35-350)	1044 (72)	2900 (200)
X = 73	35	500-5000 (35-350)	1044 (72)	2900 (200)

OPTIONS

Ordering code

Description

X = 03 11.04.23.002



X = 73 11.04.23.004

Tamper resistant cap

Special settings available. Contact factory authorized representative for ordering code.

**RELIEF, DIRECT ACTING GUIDED POPPET TYPE
COMMON CAVITY**



VSBN-10A SIZE 10 04.11.55 - X - 85 - Z

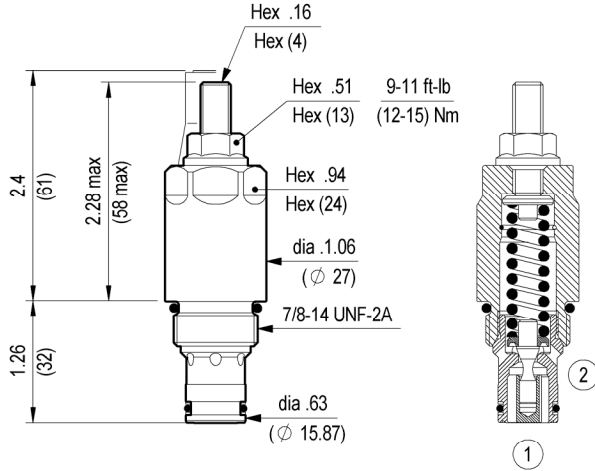

Inches
(mm)

Flow is blocked from 1 to 2 until pressure increases to meet the selected valve setting, lifting the poppet from its seat and allowing relief flow through port 2 to tank. Pressure at port 2 is additive to the relief setting of the valve. The unique Oil Control poppet design provides enhanced stability at all flows and pressures.

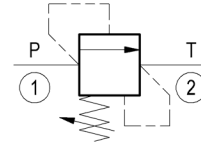

TECHNICAL DATA

Max. pressure: 5000 psi (350 bar)

Max. flow: 13 gpm (50 l/min)

Cavity : CA-10A-2N (see page CT.A.001.U)

Line bodies : see page MN1.A...

External seal kit : see page A11.011

Installation torque : 30-35 ft-lb (41-47 Nm)

Weight: 0.430 lbs (0.195 Kg)

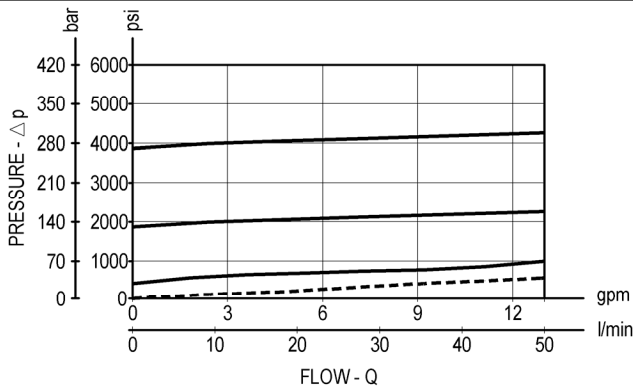

X ADJUSTMENTS

03 Leakproof hex. socket screw



Z SPRINGS

Z	Adj. press. range psi (bar)	Press. increase psi / turn (bar/turn)	Standard setting psi (bar) (Q=5 l/min)
05	75-1000 (5-70)	232 (16)	725 (50)
10	500-2000 (35-140)	348 (24)	1450 (100)
20	1500-3000 (105-210)	783 (54)	2900 (200)
35	2500-5000 (175-350)	1218 (84)	5000 (350)

OPTIONS

Ordering code	Description
11.04.23.002	Tamper resistant cap

Special settings available. Contact factory authorized representative for ordering code.

**RELIEF, DIRECT ACTING GUIDED POPPET TYPE
COMMON CAVITY**



VSBG-10A SIZE 10 04.11.56 - X - 85 - Z

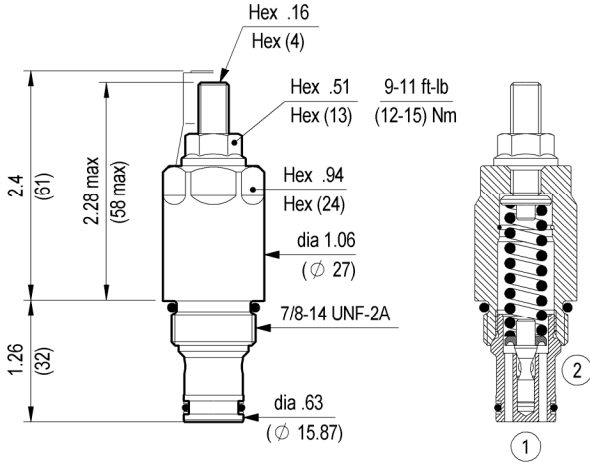

Inches
(mm)

Flow is blocked from 2 to 1 until pressure increases to meet the selected valve setting, lifting the poppet from its seat and allowing relief flow through port 1 to tank. Pressure at port 1 is additive to the relief setting of the valve. The unique Oil Control poppet design provides enhanced stability at all flows and pressures.

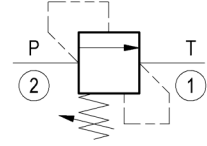

TECHNICAL DATA

Max. pressure: 5000 psi (350 bar)

Max. flow: 13 gpm (50 l/min)

Cavity : CA-10A-2N (see page CT.A.001.U)

Line bodies : see page MN1.A...

External seal kit : see page A11.011

Installation torque : 30-35 ft-lb (41-47 Nm)

Weight: 0.430 lbs (0.195 Kg)

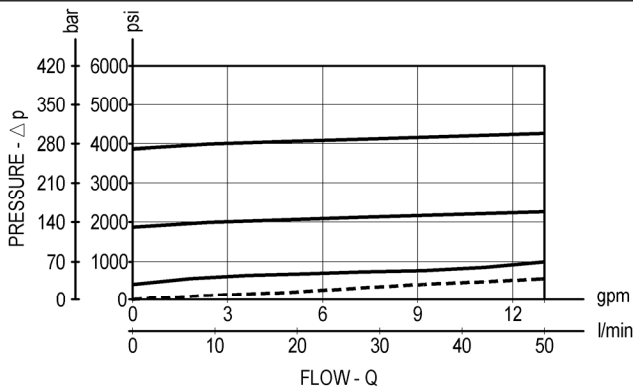

X ADJUSTMENTS

03 Leakproof hex. socket screw



Z	SPRINGS		
	Adj. press. range psi (bar)	Press. increase psi / turn (bar/turn)	Standard setting psi (bar) (Q=5 l/min)
05	75-1000 (5-70)	232 (16)	725 (50)
10	500-2000 (35-140)	348 (24)	1450 (100)
20	1500-3000 (105-210)	783 (54)	2900 (200)
35	2500-5000 (175-350)	1218 (84)	5000 (350)

OPTIONS

Ordering code

Description

11.04.23.002



Tamper resistant cap

Special settings available. Contact factory authorized representative for ordering code.

**RELIEF, BI-DIRECTIONAL
DIRECT ACTING POPPET TYPE DIFFERENTIAL AREA
COMMON CAVITY**

VSNG-10A

SIZE 10

04.11.59 - X - 85 - Z

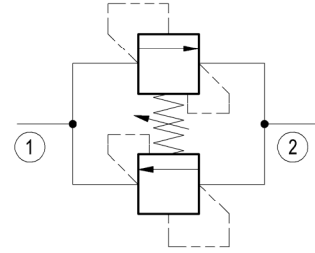
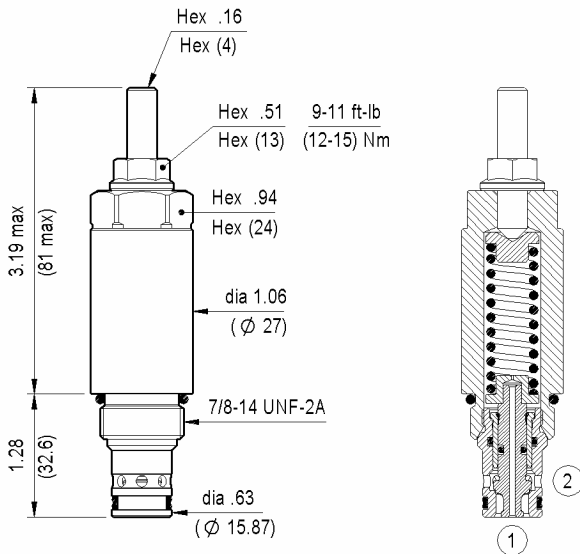

TECHNICAL DATA

Max. pressure: 5000 psi (350 bar)

Max. flow: 15 gpm (56 l/min)

Cavity : CA-10A-2N (see page CT.A.001.U)

Line bodies : see page MN1.A...

External seal kit : see page A11.011

Installation torque : 30-35 ft-lb (41-47 Nm)

Weight: 0.551 lbs (0.250 Kg)

Flow is blocked bi-directionally between 1 and 2 until pressure at either port increases to meet the selected valve setting, lifting the poppet from its seat and allowing relief flow to the opposite port. The unique Oil Control poppet design provides consistent cracking pressures at both ports and enhanced stability at all flows and pressures.

Maximum difference for crack pressure in both direction : 145 psi (10 bar)

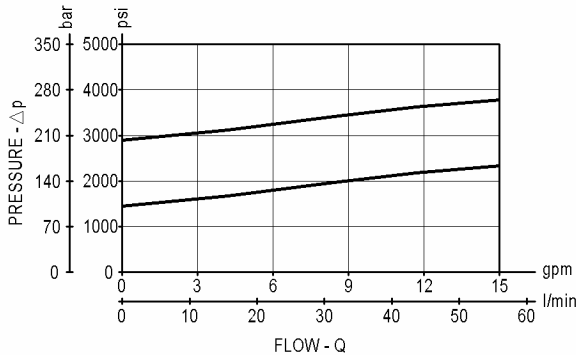

X ADJUSTMENTS

03 Leakproof hex. socket screw



SPRINGS

Z	SPRINGS			
	Adj. press. range psi (bar)	Press. increase psi / turn (bar/turn)	Standard setting psi (bar) (Q=5 l/min)	
10	450-1450 (30-100)	196 (13.5)	1450 (100)	
20	1450-3000 (100-210)	450 (31)	2900 (200)	

**RELIEF, PILOT OPERATED SPOOL TYPE
 COMMON CAVITY**

VSPN-10A

SIZE 10

04.12.08 - X - 85 - Z

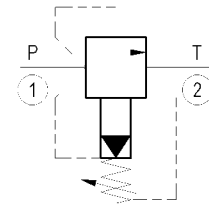
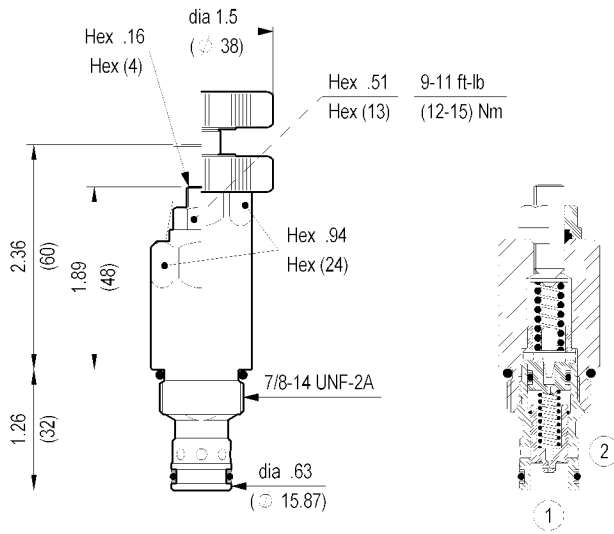

TECHNICAL DATA

Max. pressure:	6000 psi	(420 bar)
Max. flow:	32 gpm	(120 l/min)
Int. leakage ave. :	2900 psi 12 in ³ /min	(200 bar) (200 cm ³ /min)
Cavity : CA-10A-2N (see page CT.A.001.U)		
Line bodies : see page MN1.A...		
External seal kit : see page A11.011		
Installation torque :	30-35 ft-lb	(41-47 Nm)
Weight:	0.463 lbs	(0.210 Kg)

Flow is blocked from 1 to 2 until pressure increases to meet the selected valve setting, lifting the conical, pilot-stage poppet from its seat. This action exhausts oil above the main-stage piston (spool type), allowing it to shift and provide relief flow through 2 to tank. Pressure at 2 is additive to the relief setting of the valve.

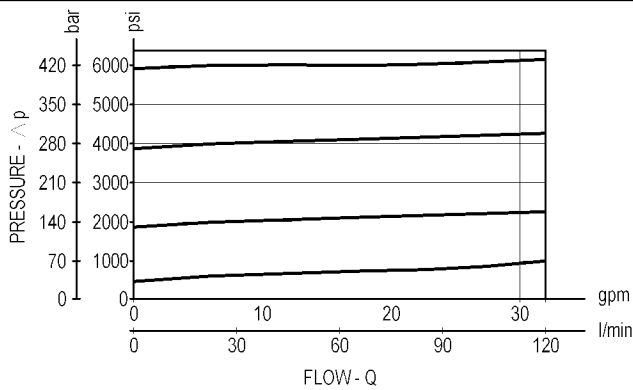

X ADJUSTMENTS

03	Leakproof hex. socket screw	
04	Handknob and locknut	

Z

SPRINGS

		Adj. press. range psi (bar)	Press. increase psi / turn (bar/turn)	Standard setting psi (bar) (Q=5 l/min)
X = 03	10	500-2000 (35-140)	696 (48)	1450 (100)
	20	1000-4000 (70-280)	1276 (88)	2900 (200)
	35	2000-6000 (140-420)	2030 (140)	5000 (350)
X = 04	35	500-5000 (35-350)	986 (68)	5000 (350)

OPTIONS

Ordering code	Description
11.04.23.002	 Tamper resistant cap

Special settings available. Contact factory authorized representative for ordering code.

**RELIEF, PILOT OPERATED SPOOL TYPE
EXTERNAL DRAIN
COMMON CAVITY**



VSPY-10A

SIZE 10

04.13.05 - X - 85 - Z

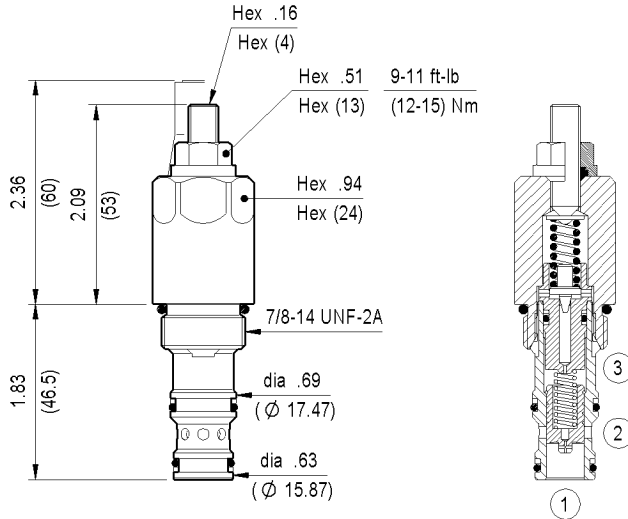

Inches
(mm)

Flow is blocked from 1 to 2 until pressure increases to meet the selected valve setting, lifting the conical, pilot-stage poppet from its seat. This action exhausts oil above the main-stage piston (spool type), allowing it to shift and provide relief flow through 2 to tank. The spring chamber is drained to tank at 3 allowing a consistent relief setting independent of back-pressure at 2.

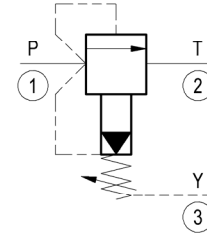

TECHNICAL DATA

Max. pressure:	6000 psi	(420 bar)
Max. flow:	32 gpm	(120 l/min)
Int. leakage ave. :	2900 psi 12 in ³ /min	(200 bar) (200 cm ³ /min)
Cavity : CA-10A-3N (see page CT.A.003.U)		
Line bodies : see page MN1.A...		
External seal kit : see page A11.011		
Installation torque :	30-35 ft-lb	(41-47 Nm)
Weight:	0.463 lbs	(0.210 Kg)

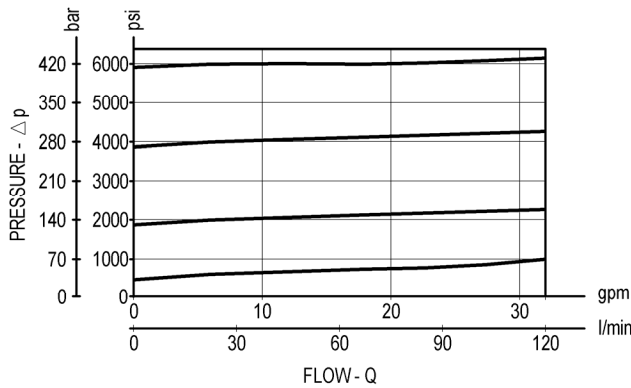

X ADJUSTMENTS

03 Leakproof hex. socket screw



SPRINGS

Z	Adj. press. range psi (bar)	Press. increase psi / turn (bar/turn)	Standard setting psi (bar) (Q=5 l/min)
10	500-2000 (35-140)	696 (48)	1450 (100)
20	1000-4000 (70-280)	1276 (88)	2900 (200)
35	2000-6000 (140-420)	2030 (140)	5000 (350)

OPTIONS

Ordering code

Description

11.04.23.002



Tamper resistant cap

Special settings available. Contact factory authorized representative for ordering code.

**PRESSURE REDUCING, PILOT OPERATED SPOOL TYPE
 COMMON CAVITY**

VRPP-10A

SIZE 10

04.93.06 - X - 85 - Z

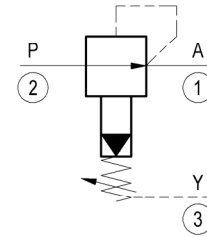
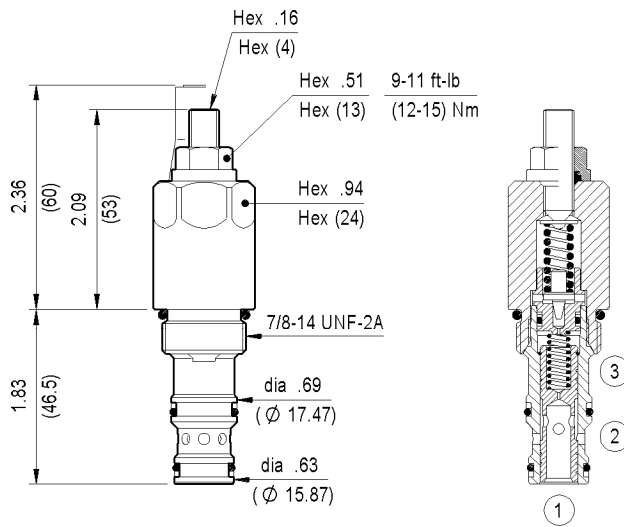

TECHNICAL DATA

Max. pressure:	5000 psi	(350 bar)
Max. regulated pressure:	4000 psi	(280 bar)
Max. flow:	16 gpm	(60 l/min)
Cavity : CA-10A-3N (see page CT.A.003.U)		
Line bodies : see page MN1...		
External seal kit : see page A11.011		
Installation torque :	30-35 ft-lb	(41-47 Nm)
Weight:	0.463 lbs	(0.210 Kg)
Std. internal orifice :	0.6 mm	

Inches
(mm)

Initially, flow passes freely from 2 to 1. When the pressure at 1 exceeds the pressure setting, the valve acts to restrict input flow at 2. This increases the pressure drop through the valve and maintains consistent pressure at 1. The spring chamber is drained at 3 to prevent a build-up of back-pressure against the spool.

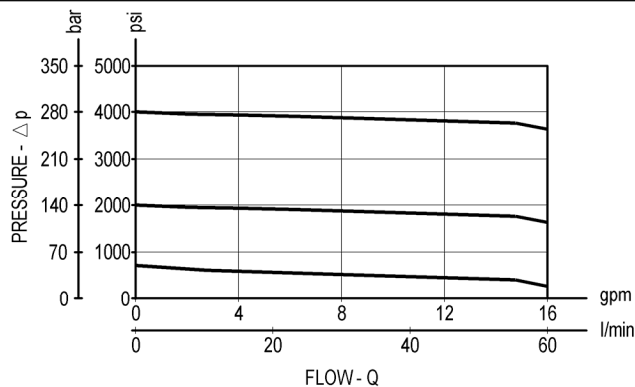

X ADJUSTMENTS

03 Leakproof hex. socket screw



SPRINGS

Z	SPRINGS		
	Adj. press. range psi (bar)	Press. increase psi / turn (bar/turn)	Standard setting psi (bar)
10	145-2000 (10-140)	696 (48)	1450 (100)
20	1000-4000 (70-280)	1276 (88)	2900 (200)

OPTIONS

Ordering code

Description

11.04.23.002

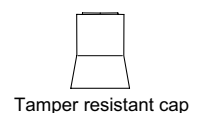

Special settings available. Contact factory authorized representative for ordering code.

**PRESSURE REDUCING AND RELIEVING,
 PILOT OPERATED SPOOL TYPE
 COMMON CAVITY**

VRPX-10A

SIZE 10

04.93.07 - X - 85 - Z

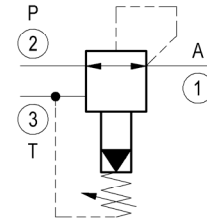
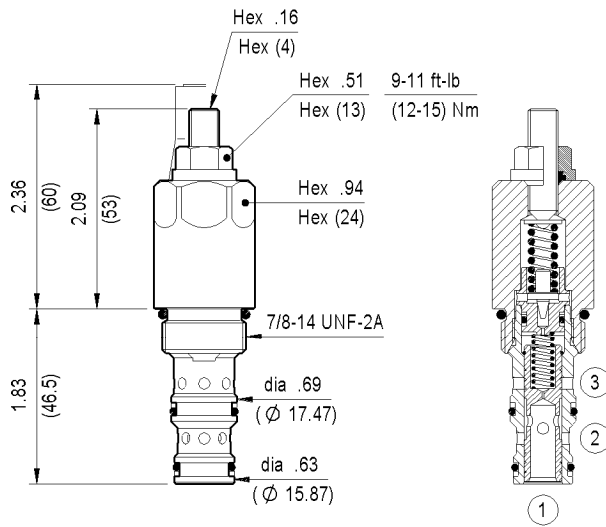

TECHNICAL DATA

Max. pressure:	5000 psi	(350 bar)
Max. flow:	16 gpm	(60 l/min)
Cavity : CA-10A-3N (see page CT.A.003.U)		
Line bodies : see page MN1.A...		
External seal kit : see page A11.011		
Installation torque :	30-35 ft-lb	(41-47 Nm)
Weight:	0.441 lbs	(0.200 Kg)
Std. internal orifice : 0.6 mm		

Inches
(mm)

Initially, flow passes freely from 2 to 1. When the pressure at 1 exceeds the pressure setting, the conical poppet in the upper, pilot stage is lifted from its seat. This allows the main-stage piston to shift, restricting input flow at 2. This increases the pressure drop through the valve and maintains consistent pressure at 1. The spring chamber is drained at 3 to prevent a build-up of back-pressure against the spool. Additionally, if pressure at 1 rises above the pressure setting, flow is relieved to 3 until the setting is re-attained.

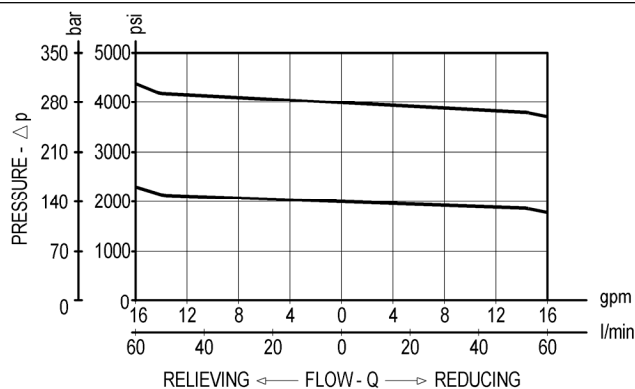

X ADJUSTMENTS

03 Leakproof hex. socket screw



Z SPRINGS

Z	Adj. press. range psi (bar)	Press. increase psi / turn (bar/turn)	Standard setting psi (bar) (reduc. mode)
10	500-2000 (35-140)	696 (48)	1450 (100)
20	1000-4000 (70-280)	1276 (88)	2900 (200)

OPTIONS

Ordering code

Description

11.04.23.002

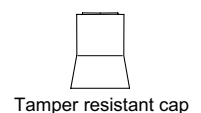

Special settings available. Contact factory authorized representative for ordering code.

**PRESSURE REDUCING AND RELIEVING,
 DIRECT ACTING SPOOL TYPE
 COMMON CAVITY**

VRPR-10A

SIZE 10

04.95.04 - X - 85 - Z

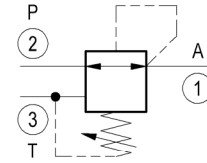
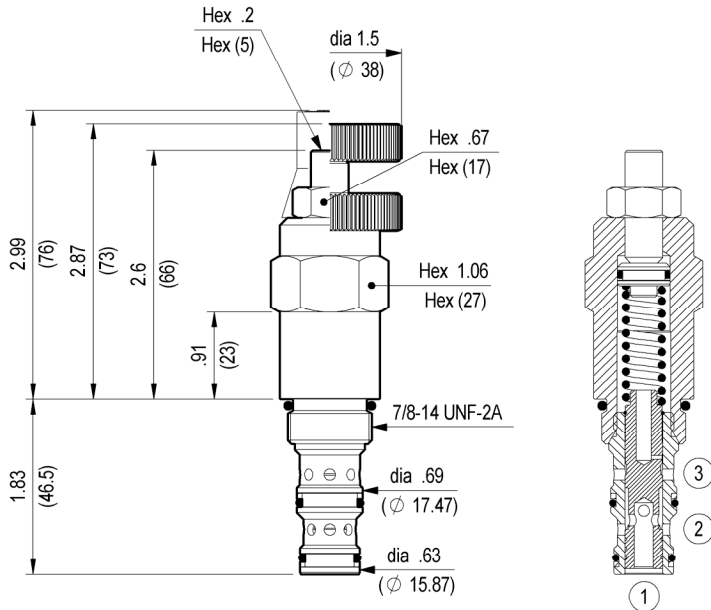

TECHNICAL DATA

Max. pressure (*):	5000 psi	(350 bar)
Max. flow:	8 gpm	(30 l/min)
Int. leakage ave. :	3 in ³ /min	(50 cm ³ /min)
Cavity : CA-10A-3N (see page CT.A.003.U)		
Line bodies : see page MN1.A...		
External seal kit : see page A11.011		
Installation torque :	30-35 ft-lb	(41-47 Nm)
Weight:	0.573 lbs	(0.260 Kg)
(*) Max pressure for Z=01 version	3000 psi	(210 bar)

Initially, flow passes freely from 2 to 1. When the pressure at 1 exceeds the pressure setting, the valve acts to restrict input flow at 2. This increases the pressure drop through the valve and maintains consistent pressure at 1. The spring chamber is drained at 3 to prevent a build-up of back-pressure against the spool. Additionally, if pressure at 1 rises above the pressure setting, flow is relieved to 3 until the setting is re-attained.

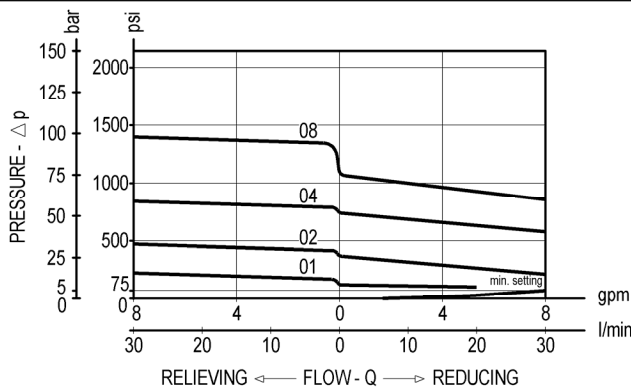

X ADJUSTMENTS

03	Leakproof hex. socket screw	
04	Handknob and locknut	

SPRINGS

Z	Adj. press. range psi (bar)	Press. increase psi / turn (bar/turn)	Standard setting psi (bar) (reduc. mode)
01	30-200 (2-14)	29 (2)	115-145 (8-10)
02	30-350 (2-25)	44 (3)	100-145 (7-10)
04	145-725 (10-50)	102 (7)	500-580 (35-40)
08	400-1160 (28-80)	203 (14)	650-725 (45-50)

OPTIONS

Ordering code	Description
11.04.23.004	 Tamper resistant cap

Special settings available. Contact factory authorized representative for ordering code.

Special Valves

VPN1

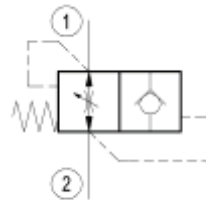

Hose burst
check valve

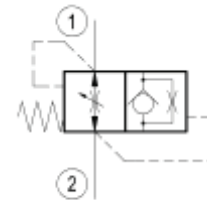

Hose burst valve
with orifice

VPN1 **OT.F4.01 - X - Y - Z**

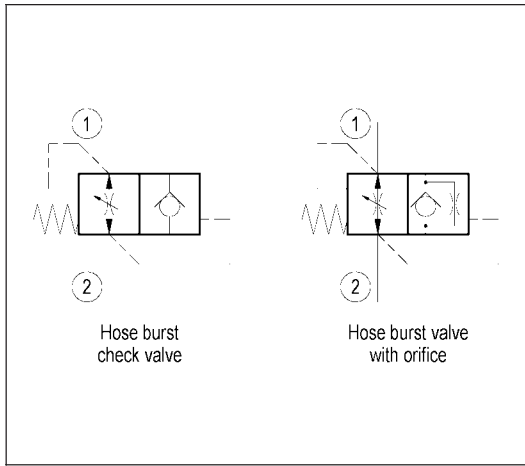
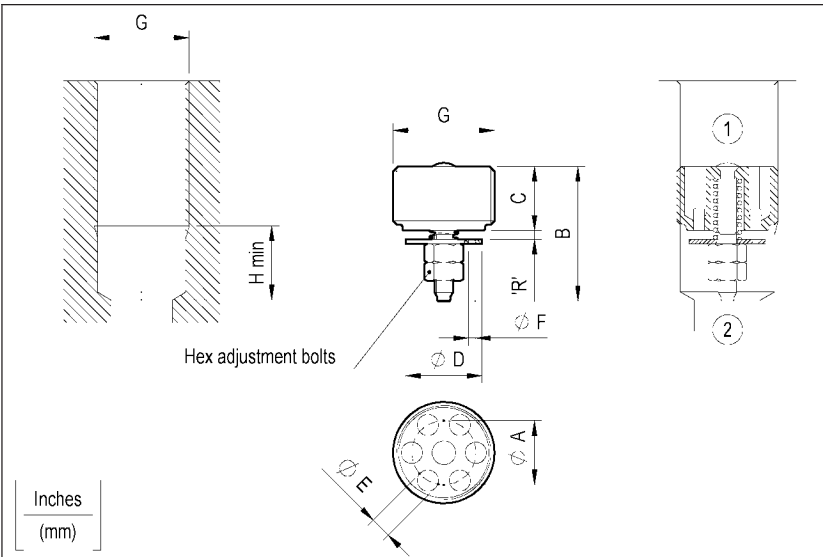

TECHNICAL DATA

Max. pressure: 4500 psi (315 bar)
 Flow: see below graphs ('R'-Q)
Special flow settings available. Please contact factory authorized representative for ordering code.
Note: on request are available as "in line mounted sleeves type configuration". Please contact factory for any information.
The valve is only supposed to be operated in case of hose failure. Should this circumstance occur, we strongly recommend to verify the integrity of the valve and eventually to replace it in the event that the pressure spike generated by the hose failure was such to damage permanently some valve components.

G	A	B	C	D	E	F	H	Hex	Weight	Inst. torque	Flow	
											min	max
G 1/4	.34 (8.5)	.69 (17.5)	.32 (8)	.37 (9.5)	.1 (2.4)	on request	.43 (11)	22 (5.5)	0.011 lbs 0.005 Kg	1.5 ft-lb 2 Nm	1 gpm 4 l/min	7 gpm 25 l/min
G 3/8	.41 (10.5)	.91 (23)	.41 (10.5)	.49 (12.5)	.14 (3.5)	on request	.43 (11)	22 (5.5)	0.022 lbs 0.010 Kg	2 ft-lb 3 Nm	2 gpm 6 l/min	13 gpm 50 l/min
G 1/2	.51 (13)	.98 (25)	.47 (12)	.59 (15)	.18 (4.5)	on request	.59 (15)	28 (7)	0.044 lbs 0.020 Kg	3 ft-lb 4 Nm	4 gpm 16 l/min	21 gpm 80 l/min
G 3/4	.63 (16)	1.2 (30.5)	.67 (17)	.71 (18)	.24 (6)	on request	.63 (16)	28 (7)	0.093 lbs 0.042 Kg	7 ft-lb 10 Nm	7 gpm 25 l/min	40 gpm 150 l/min

When the lowering speed exceeds preset value, as it might happen in case of hose failure, the flow is blocked. These valves should ideally be screwed directly into the actuator outlet port. Sealing parts are superfinished and enable to lock the load in the position where the actuator is in the moment of hose failure. These valves can be supplied, on request, with an orifice on the disc, allowing an emergency lowering of the load. It is recommended to fit a flow regulator valve downstream the hose burst valve, at the end of the flexible hose, to control the lowering speed at the nominal value. The "R" gap must be adjusted to allow a flow at least 50% over the nominal regulated flow from the actuator.

X ADJUSTMENTS

03	Locking nut + counter nut see graphs ('R' - Q)
-----------	---

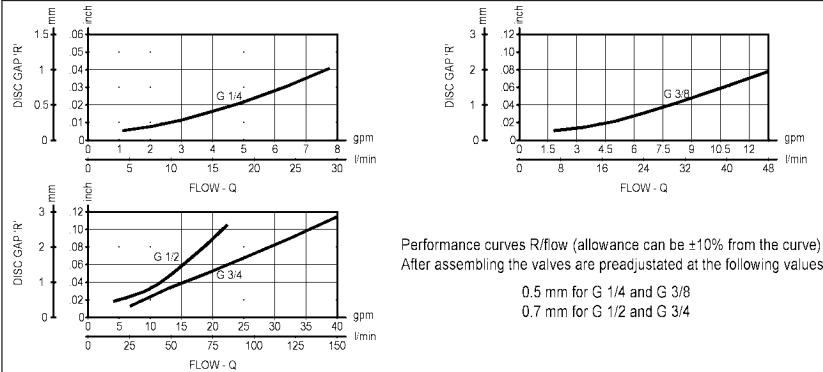

Y PORTS

09	G 1/4
02	G 3/8
03	G 1/2
04	G 3/4



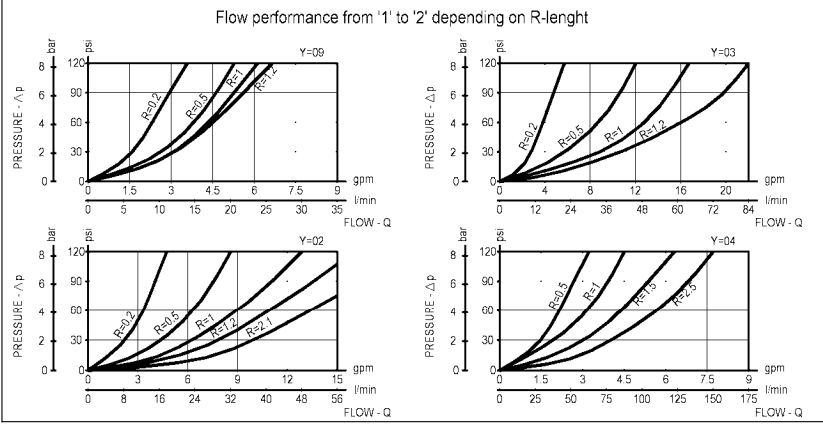

Z ORIFICE DIAMETER (mm)

00	no orifice	06	1
01	0.5	07	1.2
02	0.6	08	1.3
03	0.7	09	1.5
04	0.8	10	1.9
05	0.9	11	2

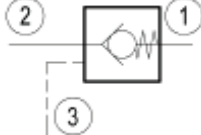
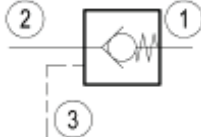
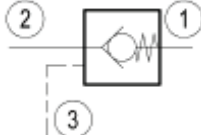
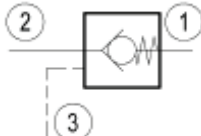
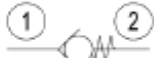

FITTING TOOL DIMENSION

Type	F	L	L1	L2	Tool's ordering code
VPN1 G14	.45 (11.3)	4.72 (120)	4.33 (110)	2.36 (60)	AVA18
VPN1 G38	.59 (15)	4.72 (120)	4.25 (108)	3.15 (80)	AVA18-01
VPN1 G12	.74 (18.8)	4.72 (120)	4.25 (108)	3.15 (80)	AVA18-02
VPN1 G34	.95 (24)	4.72 (120)	4.25 (108)	3.15 (80)	AVA18-03

Check Valves	
VUH1	
VSON-08A	
VSON-10A	
VSON-12A	
VSON-16A	
VUCN-08A	
VUCN-10A	
VUCN-12A	
VUCN-16A	

VUH1

0T.U5.01.00 - Y - Z

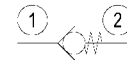
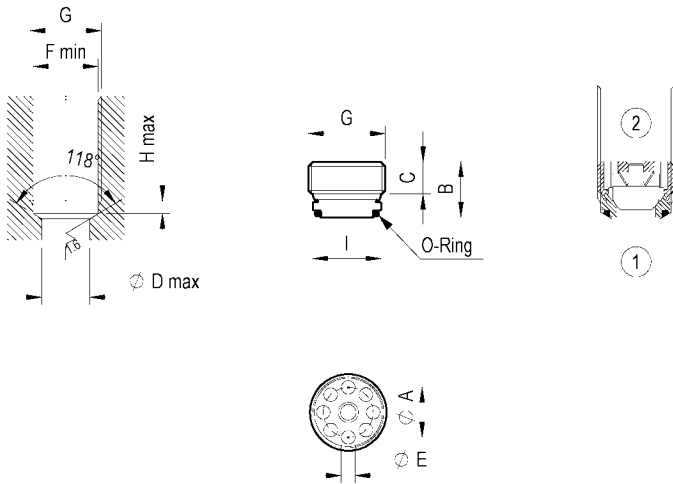

TECHNICAL DATA

Max. pressure: 5000 psi (350 bar)

Max. flow : see diagram

Note : valves are burnished.

Inches													
G	A	B	C	D	E	F	O-Ring	H	I	Weight	Inst. torque	Flow max.	
G 1/4	.34 (8.5)	.35 (8.8)	.17 (4.2)	.28 (7)	.09 (2.2)	.46 (11.6)	dia .32x.06 Ø 8.1x1.6	.12 (3)	.45 (11.3)	0.011 lbs 0.005 Kg	4 ft-lb 6 Nm	5 gpm 20 l/min	
G 3/8	.43 (10.8)	.47 (12)	.28 (7)	.35 (9)	.12 (3)	.6 (15.1)	dia .43x.06 Ø 11x1.5	.12 (3)	.58 (14.8)	0.033 lbs 0.015 Kg	4 ft-lb 6 Nm	13 gpm 50 l/min	
G 1/2	.56 (14.2)	.58 (14.7)	.32 (8)	.47 (12)	.15 (3.8)	.74 (18.8)	dia .55x.06 Ø 14x1.5	.18 (4.5)	.73 (18.6)	0.033 lbs 0.015 Kg	7 ft-lb 10 Nm	21 gpm 80 l/min	

When pressure at 1 rises above the spring bias pressure, the poppet is lifted and flow allowed from 1 to 2. The valve is closed (checked) from 2 to 1. Precision machining and hardening processes allow virtually leak-free performance in the checked condition.

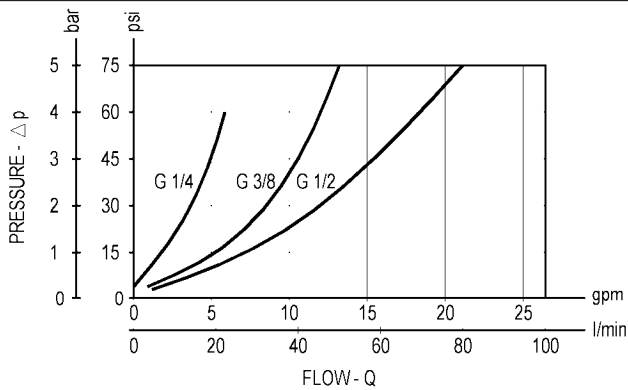

FITTING TOOL DIMENSION

Type	F	L	L1	L2	Tool code
VUH1 G14	.45 (11.3)	4.72 (120)	4.33 (110)	2.36 (60)	AVA17
VUH1 G38	.59 (14.9)	4.72 (120)	4.25 (108)	3.15 (80)	AVA17-01
VUH1 G12	.73 (18.6)	4.72 (120)	4.25 (108)	3.15 (80)	AVA17-02

Z	Cracking pressure psi (bar)				
00	< 7 (< 0.5)				

Y	PORTS
09	G 1/4
02	G 3/8
03	G 1/2

**PILOT OPERATED CHECK, PILOT TO OPEN
COMMON CAVITY**



VSON-08A

SIZE 08

04.33.06 - X - 56 - Z

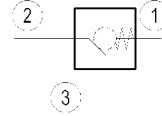
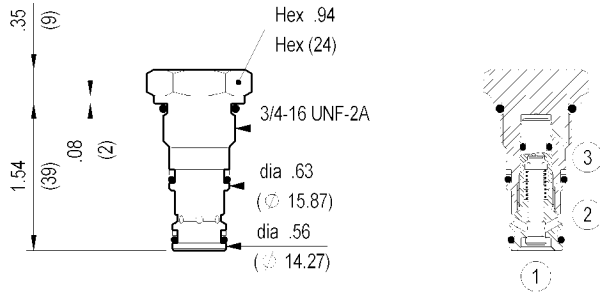

TECHNICAL DATA

Max. pressure: 5000 psi (350 bar)

Max. flow: 8 gpm (30 l/min)

Pilot ratio : 3 : 1

Cavity : CA-08A-3C (see page CT.A.002.U)

Line bodies : see page MN1.A...

External seal kit : see page A11.011

Installation torque : 25-30 ft-lb (34-41 Nm)

Weight: 0.265 lbs (0.120 Kg)

Inches
(mm)

When pressure at 2 rises above the spring bias pressure, the poppet is pushed from its seat and flow is allowed from 2 to 1. The valve is normally closed (checked) from 1 to 2. When sufficient pilot pressure is present at port 3, the pilot piston acts to push the poppet from its seat and flow is allowed from 1 to 2. Precision machining and hardening processes allow virtually leak-free performance in the checked condition.

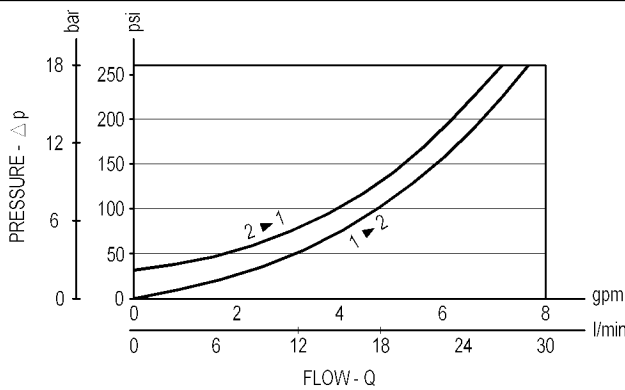

X O-RING ON PILOT PISTON

00 No O-Ring

10 With O-Ring

Z	SPRINGS			
	Cracking pressure psi (bar)			
00	30 (2)			

**PILOT OPERATED CHECK, PILOT TO OPEN
 COMMON CAVITY**

VSON-10A

SIZE 10

04.33.05 - X - 85 - Z

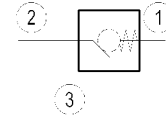
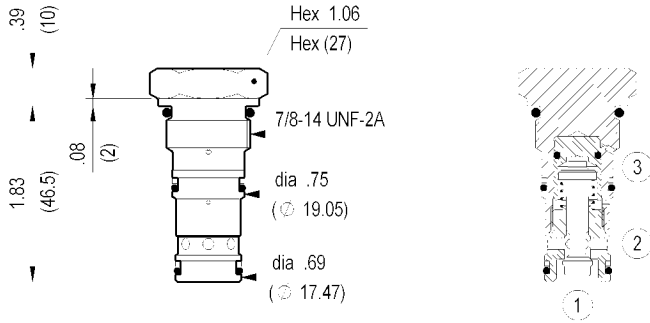

TECHNICAL DATA

Max. pressure: 5000 psi (350 bar)

Max. flow: 16 gpm (60 l/min)

Pilot ratio : 3.2 : 1

Cavity : CA-10A-3C (see page CT.A.002.U)

Line bodies : see page MN1.A...

External seal kit : see page A11.011

Installation torque : 30-35 ft-lb (41-47 Nm)

Weight: 0.265 lbs (0.120 Kg)

When pressure at 2 rises above the spring bias pressure, the poppet is pushed from its seat and flow is allowed from 2 to 1. The valve is normally closed (checked) from 1 to 2. When sufficient pilot pressure is present at port 3, the pilot piston acts to push the poppet from its seat and flow is allowed from 1 to 2. Precision machining and hardening processes allow virtually leak-free performance in the checked condition.

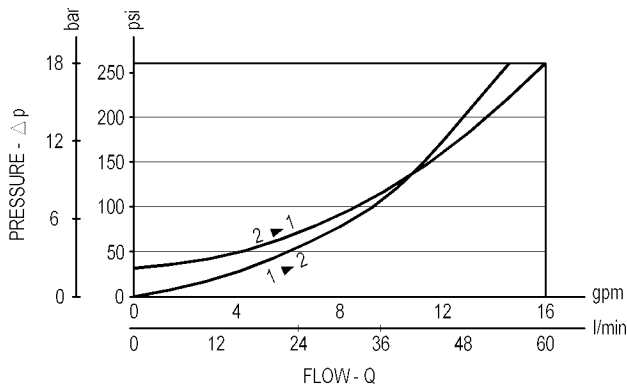

X O-RING ON PILOT PISTON

00 No O-Ring

10 With O-Ring

SPRINGS

Z	SPRINGS				
	Cracking pressure psi (bar)				
00	30 (2)				

**PILOT OPERATED CHECK, PILOT TO OPEN
COMMON CAVITY**



VSON-12A

SIZE 12

04.33.07 - X - 57 - Z

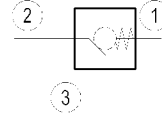
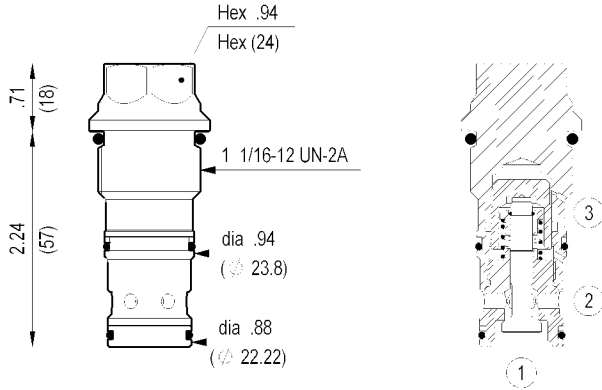

TECHNICAL DATA

Max. pressure: 5000 psi (350 bar)

Max. flow: 32 gpm (120 l/min)

Pilot ratio : 3.2 : 1

Cavity : CA-12A-3C (see page CT.A.002.U)

Line bodies : see page MN1.A...

External seal kit : see page A11.011

Installation torque : 60-70 ft-lb (81-95 Nm)

Weight: 0.551 lbs (0.250 Kg)

Inches
(mm)

When pressure at 2 rises above the spring bias pressure, the poppet is pushed from its seat and flow is allowed from 2 to 1. The valve is normally closed (checked) from 1 to 2. When sufficient pilot pressure is present at port 3, the pilot piston acts to push the poppet from its seat and flow is allowed from 1 to 2. Precision machining and hardening processes allow virtually leak-free performance in the checked condition.

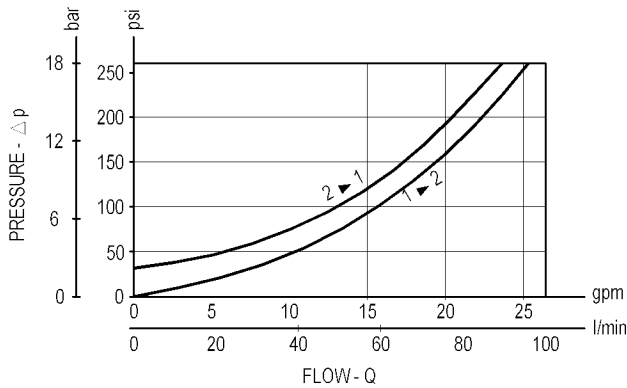

X O-RING ON PILOT PISTON

00 No O-Ring

10 With O-Ring

Z	SPRINGS			
	Cracking pressure psi (bar)			
00	30 (2)			

**PILOT OPERATED CHECK, PILOT TO OPEN
 COMMON CAVITY**

VSON-16A

SIZE 16

04.33.08 - X - 27 - Z

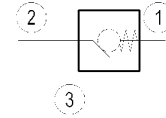
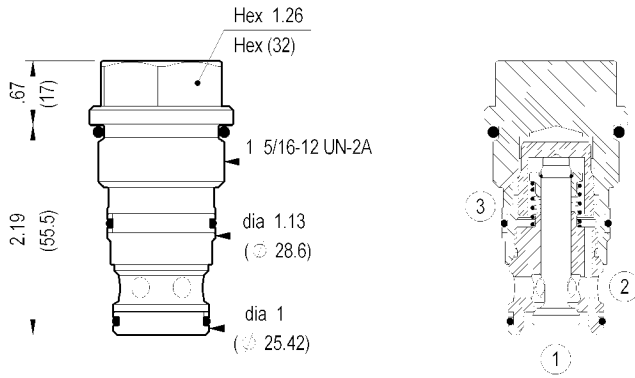

TECHNICAL DATA

Max. pressure:	5000 psi	(350 bar)
Max. flow:	53 gpm	(200 l/min)
Pilot ratio :	3 : 1	
Cavity :	CA-16A-3C (see page CT.A.002.U)	
Line bodies :	see page MN1.A...	
External seal kit :	see page A11.012	
Installation torque :	80-90 ft-lb	(108-122 Nm)
Weight:	0.706 lbs	(0.320 Kg)

Inches
(mm)

When pressure at 2 rises above the spring bias pressure, the poppet is pushed from its seat and flow is allowed from 2 to 1. The valve is normally closed (checked) from 1 to 2. When sufficient pilot pressure is present at port 3, the pilot piston acts to push the poppet from its seat and flow is allowed from 1 to 2. Precision machining and hardening processes allow virtually leak-free performance in the checked condition.

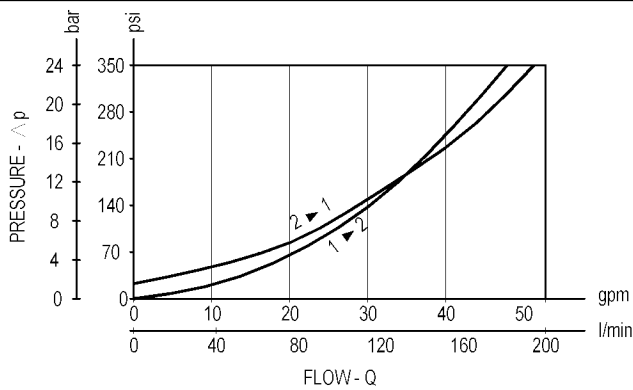

X O-RING ON PILOT PISTON

00 No O-Ring

10 With O-Ring

SPRINGS

Z	Cracking pressure			
	psi	bar		
00	22	(1.5)		

**CHECK, POPPET TYPE
COMMON CAVITY**

VUCN-08A

SIZE 08

04.31.20.00.56 - Z

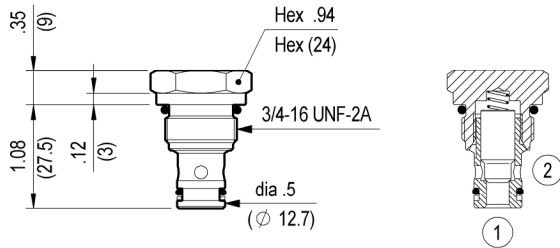

TECHNICAL DATA

Max. pressure: 6000 psi (420 bar)

Max. flow: 13 gpm (50 l/min)

Cavity : CA-08A-2N (see page CT.A.001.U)

Line bodies : see page MN1.A...

External seal kit : see page A11.011

Installation torque : 25-30 ft-lb (34-41 Nm)

Weight: 0.265 lbs (0.120 Kg)

Inches
(mm)

When pressure at 1 rises above the spring bias pressure, the poppet is lifted and flow allowed from 1 to 2. The valve is closed (checked) from 2 to 1. Precision machining and hardening processes allow virtually leak-free performance in the checked condition.

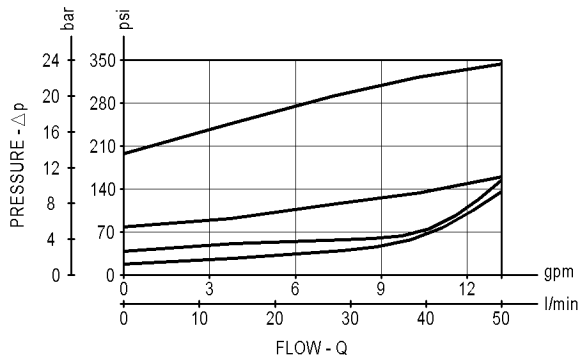

SPRINGS

Z	SPRINGS			
	Cracking pressure psi (bar)			
00	15 (1)			
03	39 (2.7)			
05	75 (5)			
14	200 (14)			

**CHECK, POPPET TYPE
COMMON CAVITY**

VUCN-10A

SIZE 10

04.31.23.00.85 - Z

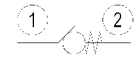
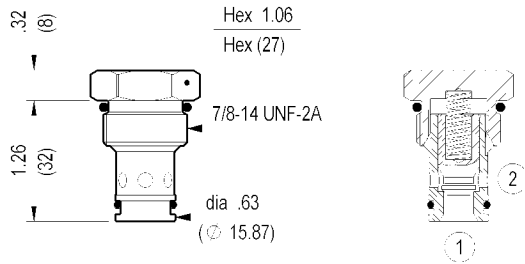

TECHNICAL DATA

Max. pressure: 5000 psi (350 bar)

Max. flow: 21 gpm (80 l/min)

Cavity : CA-10A-2N (see page CT.A.001.U)

Line bodies : see page MN1.A...

External seal kit : see page A11.011

Installation torque : 30-35 ft-lb (41-47 Nm)

Weight: 0.331 lbs (0.150 Kg)

Inches
(mm)

When pressure at 1 rises above the spring bias pressure, the poppet is lifted and flow allowed from 1 to 2. The valve is closed (checked) from 2 to 1. Precision machining and hardening processes allow virtually leak-free performance in the checked condition.

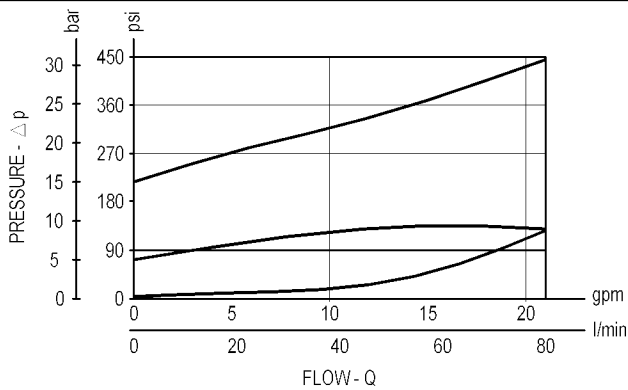

Z	SPRINGS			
	Cracking pressure psi (bar)			
00	7 (0.5)			
05	75 (5)			
15	220 (15)			

**CHECK, POPPET TYPE
 COMMON CAVITY**

VUCN-12A

SIZE 12

04.31.28.00.57 - Z

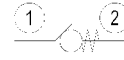
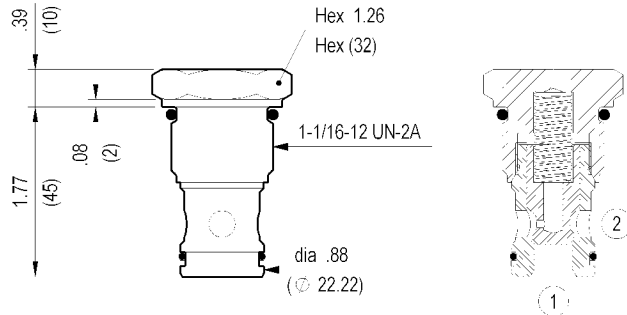

TECHNICAL DATA

Max. pressure: 5000 psi (350 bar)

Max. flow: 32 gpm (120 l/min)

Cavity : CA-12A-2N (see page CT.A.001.U)

Line bodies : see page MN1.A...

External seal kit : see page A11.011

Installation torque : 60-70 ft-lb (81-95 Nm)

Weight: 0.397 lbs (0.180 Kg)

Inches
(mm)

When pressure at 1 rises above the spring bias pressure, the poppet is lifted and flow allowed from 1 to 2. The valve is closed (checked) from 2 to 1. Precision machining and hardening processes allow virtually leak-free performance in the checked condition.

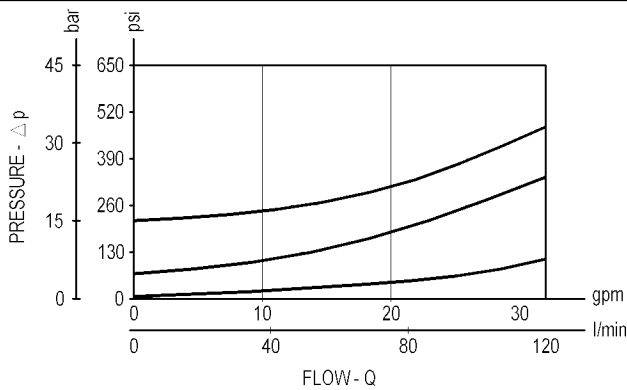

Z	SPRINGS				
	Cracking pressure psi (bar)				
00	15 (1)				
05	75 (5)				
15	220 (15)				

**CHECK, POPPET TYPE
COMMON CAVITY**

VUCN-16A

SIZE 16

04.31.25.00.27 - Z

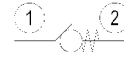
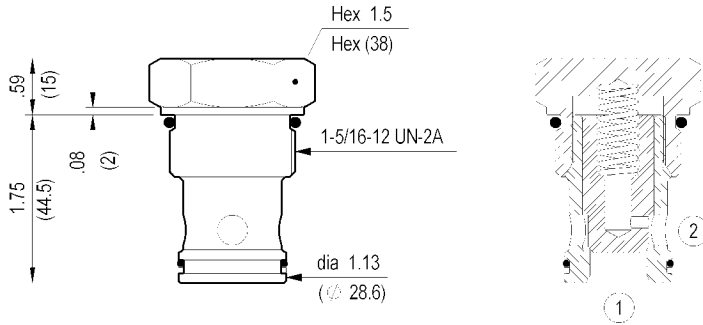

TECHNICAL DATA

Max. pressure:	5000 psi	(350 bar)
Max. flow:	53 gpm	(200 l/min)
Cavity : CA-16A-2N (see page CT.A.001.U)		
Line bodies : see page MN1.A...		
External seal kit : see page A11.012		
Installation torque :	80-90 ft-lb	(108-122 Nm)
Weight:	0.595 lbs	(0.270 Kg)

Inches
(mm)

When pressure at 1 rises above the spring bias pressure, the poppet is lifted and flow allowed from 1 to 2. The valve is closed (checked) from 2 to 1. Precision machining and hardening processes allow virtually leak-free performance in the checked condition.

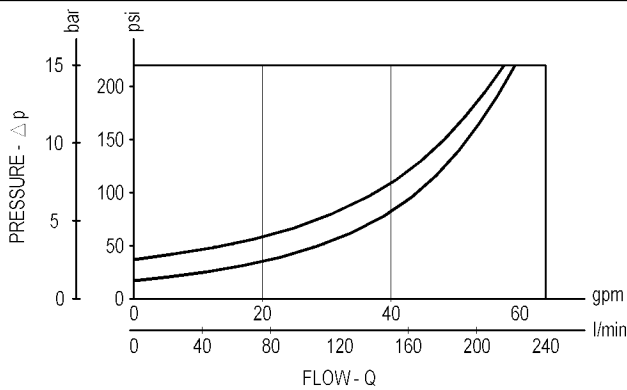

Z	SPRINGS				
	Cracking pressure psi (bar)				
00	15 (1)				
02	30 (2)				

Counterbalance Valves	
VBSN-08AA	
VBSN-10A	
VBSN-12A	
VBSN-16A	

**COUNTERBALANCE, STANDARD GUIDED POPPET TYPE
COMMON CAVITY**



VBSN-08AA

SIZE 08

04.52.20 - X - 56 - Z

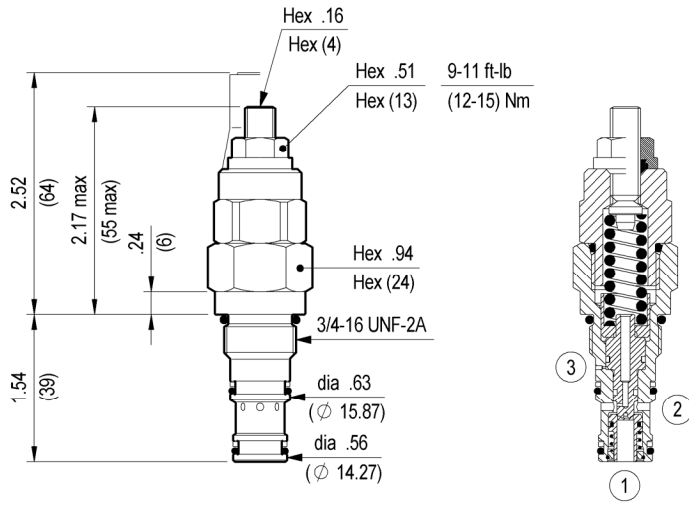

Inches
(mm)

When pressure at 2 rises above the spring bias pressure, the check seat is pushed away from the piston and flow is allowed from 2 to 1. When load pressure at 1 rises above the pressure setting, the direct-acting, relief function is activated and flow is relieved from 1 to 2. With pilot pressure at 3, the pressure setting is reduced in proportion to the stated ratio of the valve, until fully open with free-flow from 1 to 2. The spring chamber is drained to 2, and any back-pressure at 2 is additive to the pressure setting in all functions.

TECHNICAL DATA

Max. pressure: 5000 psi (350 bar)

Max. flow: 8 gpm (30 l/min)

Cavity : CA-08A-3C (see page A10.011)

Line bodies : see page A09.010 – A09.014

External seal kit : see page A11.011

Installation torque : 25-30 ft-lb (34-41 Nm)

Weight: 0.397 lbs (0.180 Kg)

Pressure setting: at least 1.3 times the load induced pressure.

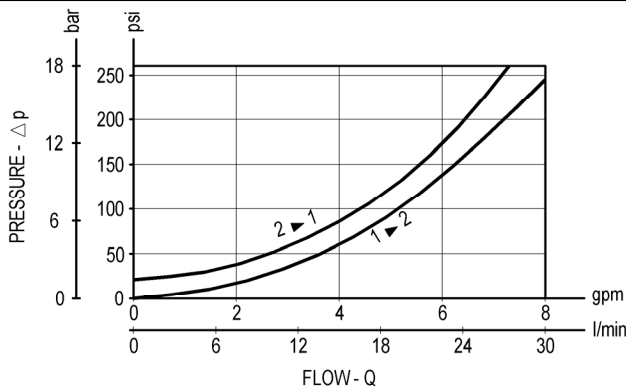

X PILOT RATIO

03 4 : 1

33 4 : 1 With sealed pilot

SPRINGS

Z	Adj. press. range psi (bar)	Press. increase psi / turn (bar/turn)	Standard setting psi (bar) (Q=5 l/min)	Ordering code
15	1000-2200 (70-150)	1051 (72.5)	2200 (150)	03.51.01.329
20	1450-3000 (100-210)	1581 (109)	2900 (200)	03.51.01.328
35	2900-5000 (200-350)	1987 (137)	5000 (350)	03.51.01.327

OPTIONS

Ordering code	Description
11.04.23.002	Tamper resistant cap

Special settings available. Contact factory authorized representative for ordering code.

**COUNTERBALANCE, STANDARD POPPET TYPE
 DIFFERENTIAL AREA
 COMMON CAVITY**

VBSN-10A

SIZE 10

04.52.31 - X - 85 - Z

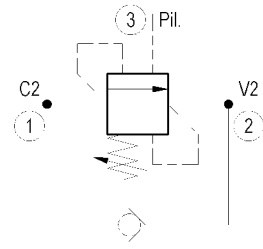
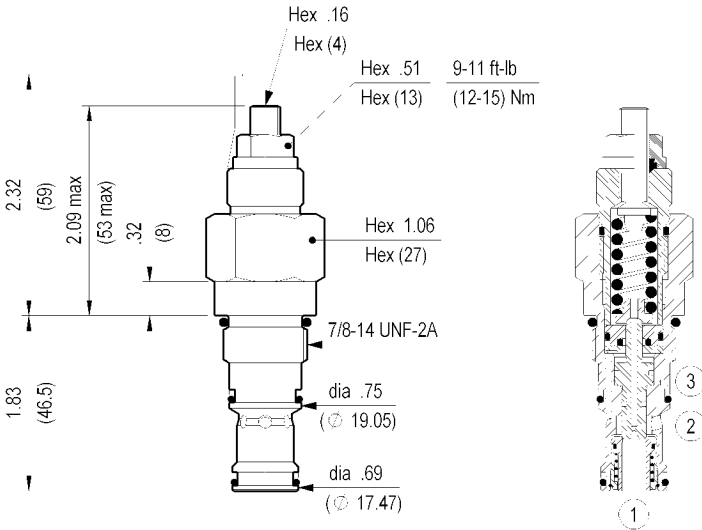

TECHNICAL DATA

Max. pressure: 5000 psi (350 bar)

Max. flow: 16 gpm (60 l/min)

Cavity : CA-10A-3C (see page CT.A.002.U)

Line bodies : see page MN1.A...

External seal kit : see page A11.011

Installation torque : 30-35 ft-lb (41-47 Nm)

Weight: 0.441 lbs (0.200 Kg)

Pressure setting: at least 1.3 times the load induced pressure

When pressure at 2 rises above the spring bias pressure, the check seat is pushed away from the piston and flow is allowed from 2 to 1. When load pressure at 1 rises above the pressure setting, the direct-acting, differential area relief function is activated and flow is relieved from 1 to 2. With pilot pressure at 3, the pressure setting is reduced in proportion to the stated ratio of the valve, until fully open with free-flow from 1 to 2. The spring chamber is drained to 2, and any back-pressure at 2 is additive to the pressure setting in all functions.

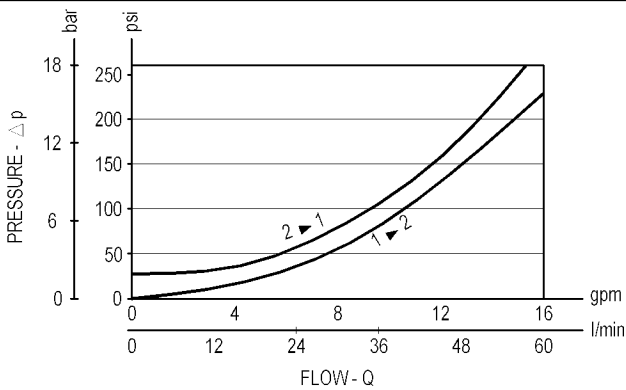

X PILOT RATIO

03 3 : 1

10 8 : 1

Z

SPRINGS

		Adj. press. range psi (bar)	Press. increase psi / turn (bar/turn)	Standard setting psi (bar) (Q=5 l/min)
X = 03	20	1000-3000 (70-210)	1958 (135)	2900 (200)
	35	2000-5000 (140-350)	2842 (196)	5000 (350)
X = 10	20	1000-3000 (70-210)	754 (52)	2900 (200)
	35	2000-5000 (140-350)	1291 (89)	5000 (350)

OPTIONS

Ordering code

Description

11.04.23.002

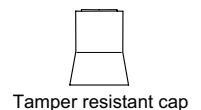

Special settings available. Contact factory authorized representative for ordering code.



**COUNTERBALANCE, STANDARD POPPET TYPE
DIFFERENTIAL AREA
COMMON CAVITY**

VBSN-12A

SIZE 12

04.52.28 - X - 57 - Z

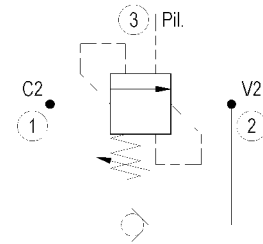
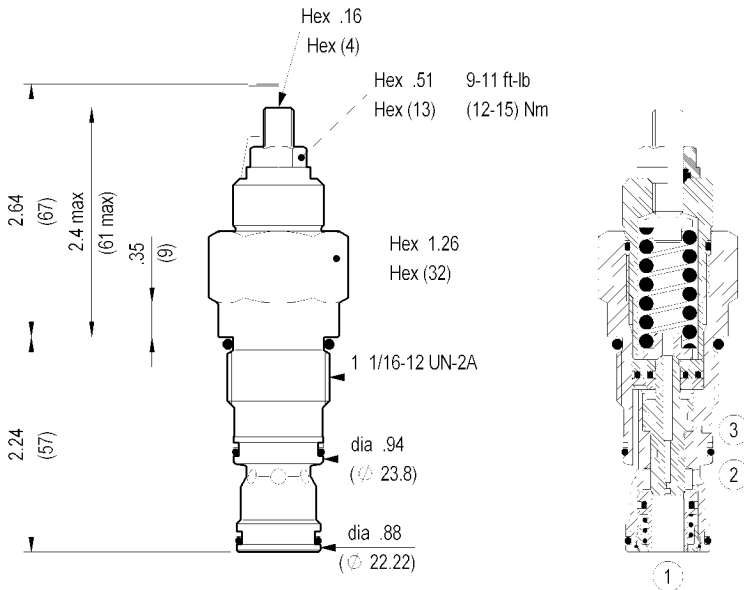

TECHNICAL DATA

Max. pressure: 5000 psi (350 bar)

Max. flow: 32 gpm (120 l/min)

Cavity : CA-12A-3C (see page CT.A.002.U)

Line bodies : see page MN1.A...

External seal kit : see page A11.011

Installation torque : 60-70 ft-lb (81-95 Nm)

Weight: 0.860 lbs (0.390 Kg)

Pressure setting: at least 1.3 times the load induced pressure

When pressure at 2 rises above the spring bias pressure, the check seat is pushed away from the piston and flow is allowed from 2 to 1. When load pressure at 1 rises above the pressure setting, the direct-acting, differential area relief function is activated and flow is relieved from 1 to 2. With pilot pressure at 3, the pressure setting is reduced in proportion to the stated ratio of the valve, until fully open with free-flow from 1 to 2. The spring chamber is drained to 2, and any back-pressure at 2 is additive to the pressure setting in all functions.

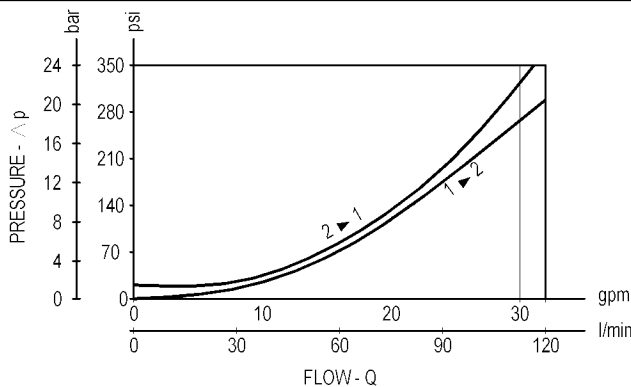

X PILOT RATIO

03 4 : 1

10 8 : 1

Z

SPRINGS

		Adj. press. range psi (bar)	Press. increase psi / turn (bar/turn)	Standard setting psi (bar) (Q=5 l/min)
X = 03	20	1000-3000 (70-210)	725 (50)	2900 (200)
	35	2000-5000 (140-350)	2306 (159)	5000 (350)
X = 10	20	1000-3000 (70-210)	609 (42)	2900 (200)
	35	2000-5000 (140-350)	972 (67)	5000 (350)

OPTIONS

Ordering code

Description

11.04.23.002

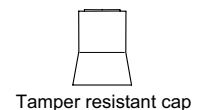

Special settings available. Contact factory authorized representative for ordering code.

**COUNTERBALANCE, STANDARD POPPET TYPE
 DIFFERENTIAL AREA
 COMMON CAVITY**

VBSN-16A

SIZE 16

04.52.29 - X - 27 - Z

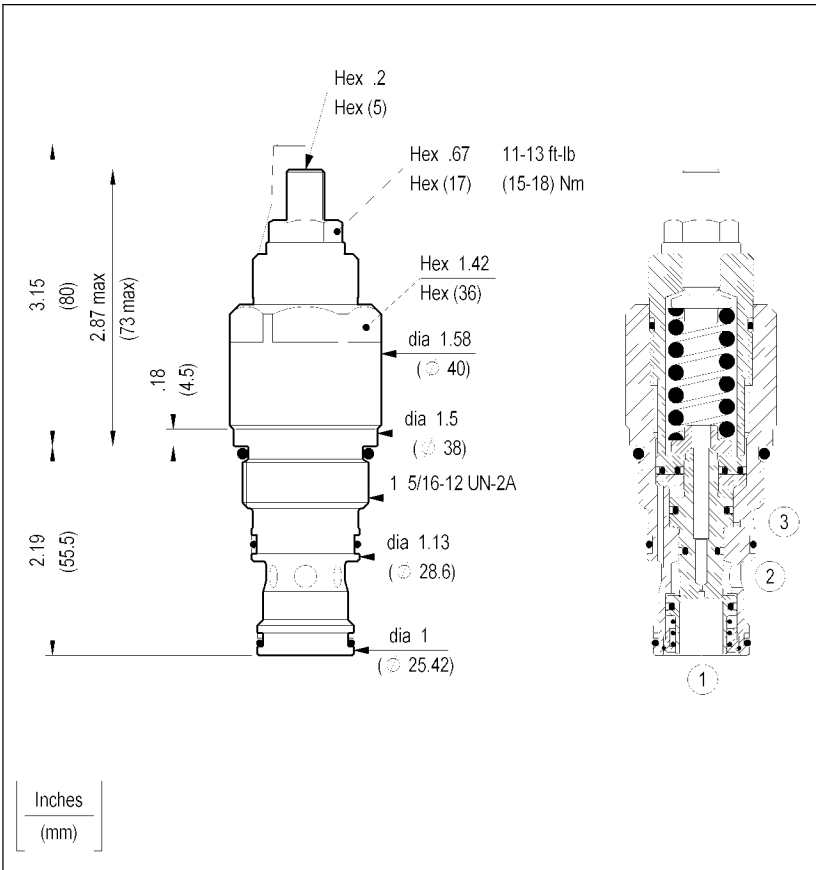

When pressure at 2 rises above the spring bias pressure, the check seat is pushed away from the piston and flow is allowed from 2 to 1. When load pressure at 1 rises above the pressure setting, the direct-acting, differential area relief function is activated and flow is relieved from 1 to 2. With pilot pressure at 3, the pressure setting is reduced in proportion to the stated ratio of the valve, until fully open with free-flow from 1 to 2. The spring chamber is drained to 2, and any back-pressure at 2 is additive to the pressure setting in all functions.

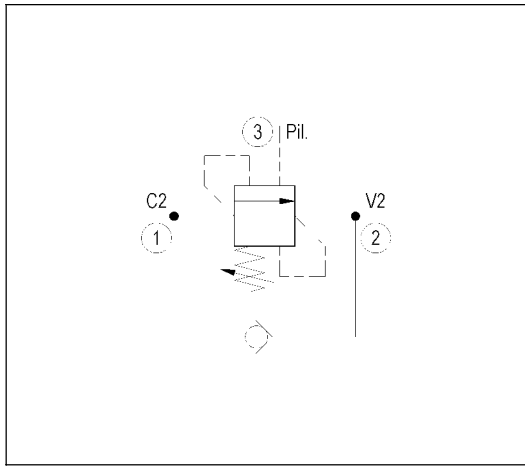



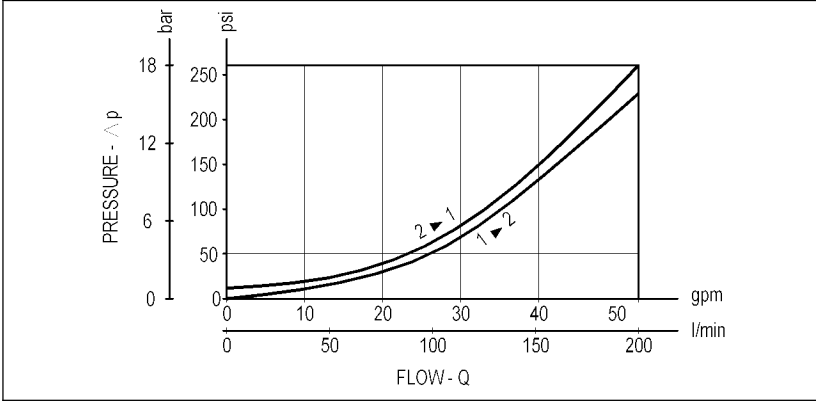



TECHNICAL DATA	
Max. pressure:	5000 psi (350 bar)
Max. flow:	53 gpm (200 l/min)
Cavity : CA-16A-3C (see page CT.A.002.U)	
Line bodies : see page MN1.A...	
External seal kit : see page A11.012	
Installation torque :	80-90 ft-lb (108-122 Nm)
Weight:	1.808 lbs (0.820 Kg)
Pressure setting: at least 1.3 times the load induced pressure	

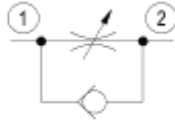

X	PILOT RATIO
03	4 : 1
10	8 : 1

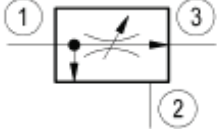
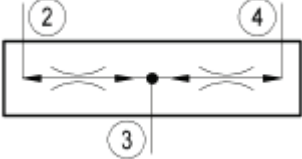
Z	SPRINGS			
	Adj. press. range psi (bar)	Press. increase psi / turn (bar/turn)	Standard setting psi (bar) (Q=5 l/min)	
X = 03	20	1000-3000 (70-210)	1015 (70)	2900 (200)
	35	2000-5000 (140-350)	1566 (108)	5000 (350)
X = 10	40	2000-6000 (140-420)	1958 (135)	5000 (350)

OPTIONS	
Ordering code	Description
11.04.23.004	 Tamper resistant cap
Special settings available. Contact factory authorized representative for ordering code.	

Flow Control Valves	
STVU-08A	
VRFB-10A	
VRFD-10	
DRFN-10A	
ST-C-06	
ST-C-10A	
ST-C-12A	
ST-C-16A	

**NEEDLE RESTRICTOR, FREE REVERSE FLOW
 COMMON CAVITY**

STVU-08A

SIZE 08

04.01.02 - X - 56.00

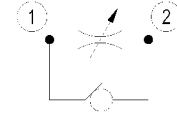
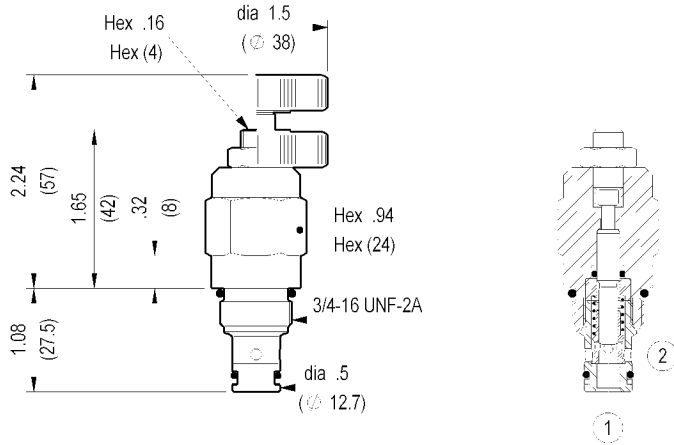

TECHNICAL DATA

Max. pressure: 5000 psi (350 bar)

Max. flow: 11 gpm (40 l/min)

Cavity : CA-08A-2N (see page CT.A.001.U)

Line bodies : see page MN1.A...

External seal kit : see page A11.011

Installation torque : 25-30 ft-lb (34-41 Nm)

Weight: 0.353 lbs (0.160 Kg)

With flow from 2 to 1, the valve provides a fully adjustable orifice restriction. Free flow is permitted from 1 to 2, regardless of valve adjustment, by when pressure overcomes the spring bias of the valve's check function.

Inches
(mm)

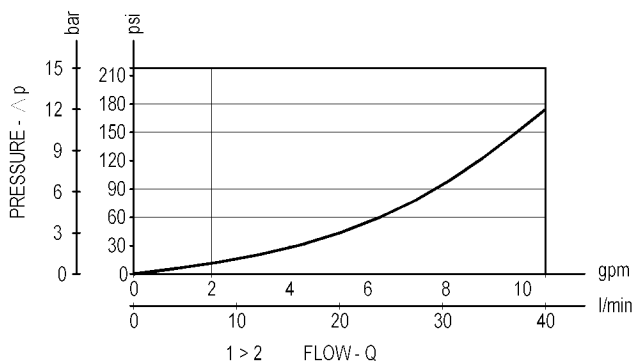
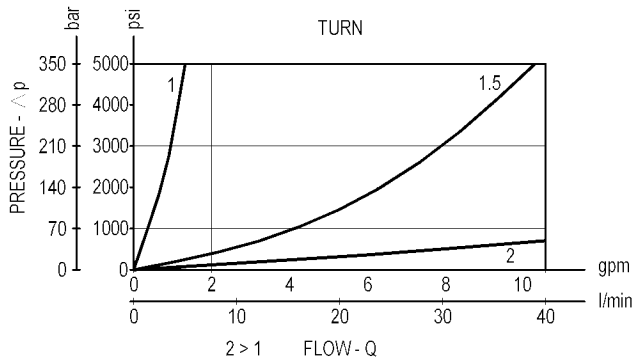

X

ADJUSTMENTS

03 Leakproof hex. socket screw



04 Handknob and locknut



**FLOW CONTROL, 2-WAY PRESSURE COMPENSATED
FULLY ADJUSTABLE
COMMON CAVITY**



VRFB-10A

SIZE 10

04.02.02 - X - 85 - Z

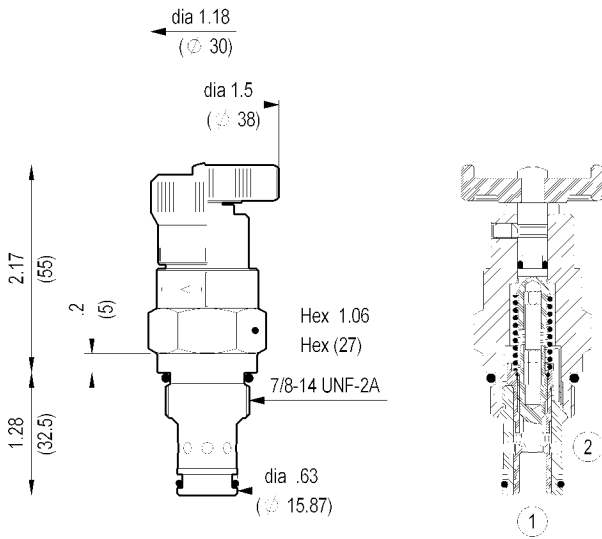

Inches
(mm)

A constant flow rate, regardless of system pressures, is established from 1 to 2 while a minimum pressure differential of 200 psi exists between the two ports. Output flow can be varied from closed to the nominal maximum rating for the valve. Flow from 2 to 1 is limited by the diameter of the selected control orifice and is not pressure compensated.

TECHNICAL DATA

Pressure min-max: 200-5000 psi (14-350 bar)

Flow range: see below

Cavity : CA-10A-2N (see page CT.A.001.U)

Line bodies : see page MN1.A...

External seal kit : see page A11.011

Installation torque : 30-35 ft-lb (41-47 Nm)

Weight: 0.595 lbs (0.270 Kg)

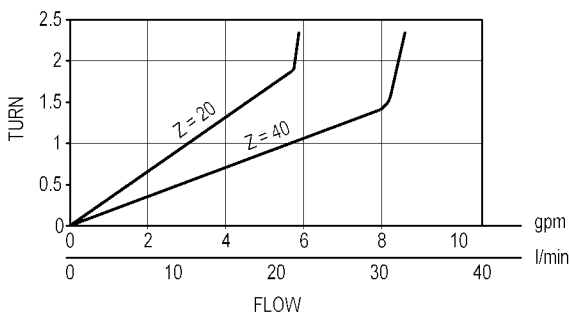
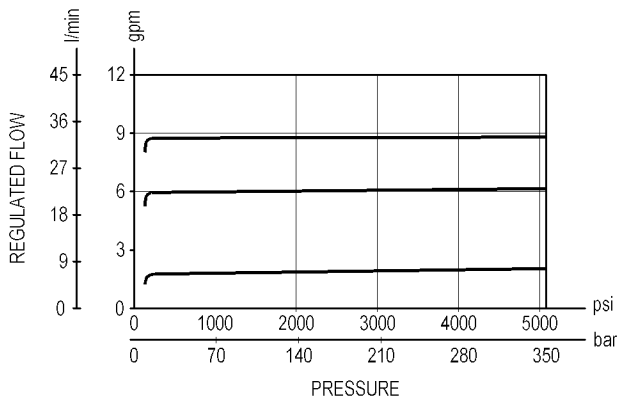

X ADJUSTMENTS

40 Calibrated handknob



04 Handknob



Z REGULATED FLOW RANGE

20	0.01-5.28 gpm	0.05-20 l/min
40	0.03-7.93 gpm	0.10-30 l/min

**FLOW CONTROL, 3-WAY PRESSURE COMPENSATED
COMBINATION TYPE FULLY ADJUSTABLE
COMMON CAVITY**



VRFD-10A SIZE 10 04.04.02 - X - 85 - Z

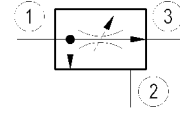
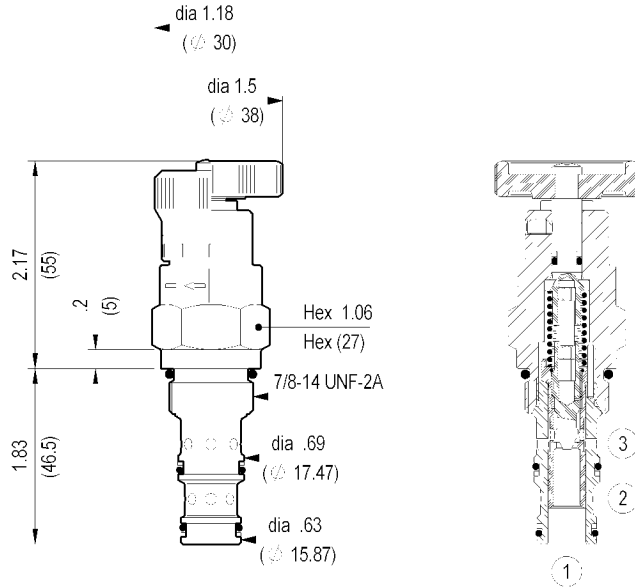

TECHNICAL DATA

Pressure min-max:	200-5000 psi	(14-350 bar)
Max inlet flow:	16 gpm	(60 l/min)
Flow range:	see below	
Cavity :	CA-10A-3N (see page CT.A.003.U)	
Line bodies :	see page MN1.A...	
External seal kit :	see page A11.011	
Installation torque :	30-35 ft-lb	(41-47 Nm)
Weight:	0.573 lbs	(0.260 Kg)

A constant flow rate, regardless of system pressures, is established from 1 to 3 while a minimum pressure differential of 200 psi exists between the two ports. Input flow supplied to 1 in excess of the regulated output at 3 is by-passed to 2. Output flow can be varied from closed to the nominal maximum rating for the valve. Flow from 3 to 1 is limited by the diameter of the selected control orifice and is not pressure compensated. Flow from 2 to 1 is not permitted.

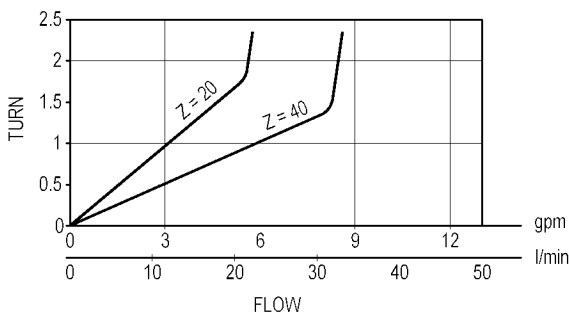
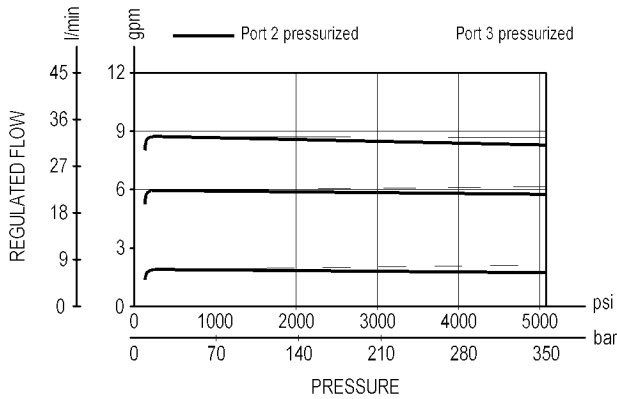

X ADJUSTMENTS

40	Calibrated handknob	
04	Handknob	

Z REGULATED FLOW RANGE

20	0.01-5.28 gpm	0.05-20 l/min
40	0.03-7.93 gpm	0.10-30 l/min

**FLOW DIVIDER AND COMBINER
 COMMON CAVITY**

DRFN-10A

SIZE 10

04.05.01.00.85 - Z

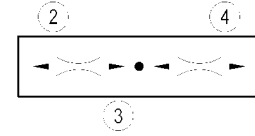
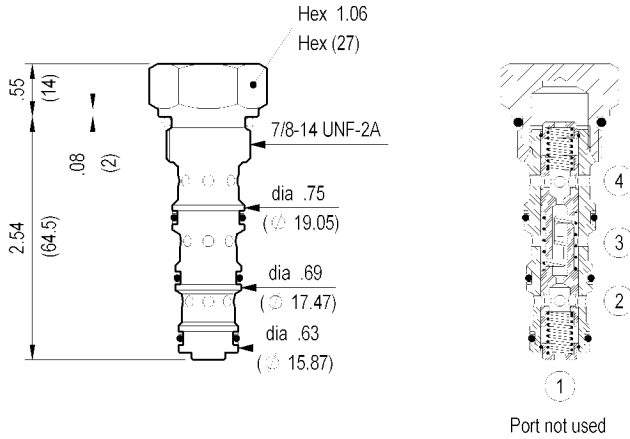

TECHNICAL DATA

Pressure min-max: 145-5000 psi (10-350 bar)

Range of rated total flow: see table Z

Division or combination ratio: 50%-50%

Cavity : CA-10A-4N (see page CT.A.004.U)

Line bodies : see page MN1.A...

External seal kit : see page A11.011

Installation torque : 30-35 ft-lb (41-47 Nm)

Weight: 0.617 lbs (0.280 Kg)

Slippage (tolerance) from theoretical divided flows:
 ±5% to ±10%, depending from inlet flow (see diagram).
 N.B.: slippage is lowest toward upper limit of nominal range.

Input flow at 3 will be divided and output equally to 2 and 4 independent of system pressures. Flow input at 2 and 4 will be combined and output at 3. Should either 2 or 4 become blocked in flow division mode, approximately 5% of the input flow will be transmitted to the open port.

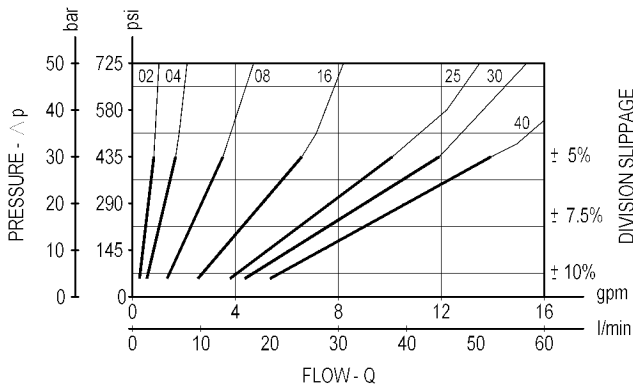

Z	RANGE OF TOTAL FLOW			
02	0.26-0.79	gpm	1-3	l/min
04	0.53-1.59	gpm	2-6	l/min
08	1.32-3.44	gpm	5-13	l/min
16	2.38-6.34	gpm	9-24	l/min
25	3.70-9.78	gpm	14-37	l/min
30	4.23-11.63	gpm	16-44	l/min
40	5.28-14.27	gpm	20-54	l/min

**FLOW CONTROL VALVES
CARTRIDGE RESTRICTORS
COMMON CAVITY**



ST-C-06

SIZE 08

OD.21.01 - X - 56

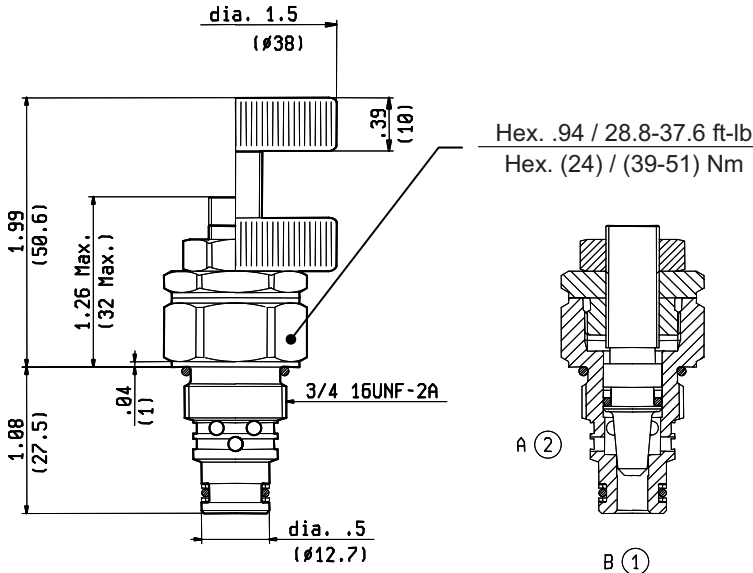

Inches
(mm)

TECHNICAL DATA

Maximum Operating Pressure	5000 psi (350 bar)
Rated Flow	11 gpm (40 l/min)
Cavity - Tooling (CA-08A-2N)	page CT.A.001.U
Line bodies	page MN2.A...
Weight	0.199 lbs (0.090 kg)
Fluids - Temperatures	page 7.01.040
Testing Conditions - Seals	page 7.01.040
Internal Leakage	page 7.01.040
Filtration : 25 µm nominal or better	page 7.01.050
Adjustment Torque at 145 psi (10 bar)	0.7 ft-lb (1 Nm)
Adjustment Torque at 5000 psi (350 bar)	3.7 ft-lb (5 Nm)
Mounting Position	unrestricted

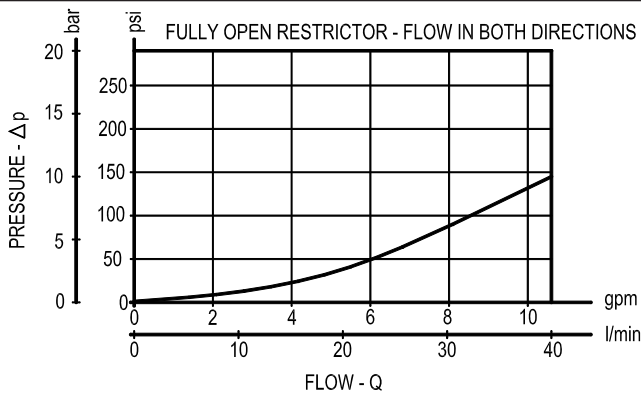

X ORDERING OPTIONS

03 Socket Screw

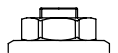

04 Handknob and Locknut

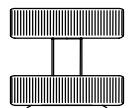

**FLOW CONTROL VALVES
 CARTRIDGE RESTRICTORS
 COMMON CAVITY**

ST-C-10A

SIZE 10

OD.21.01 - X - 36

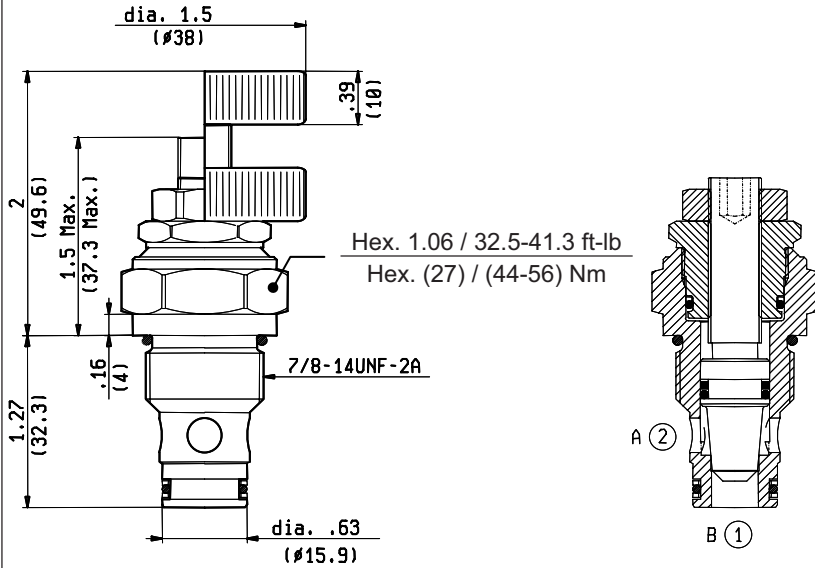

Hex. 1.06 / 32.5-41.3 ft-lb
 Hex. (27) / (44-56) Nm

Inches
 (mm)



TECHNICAL DATA

Maximum Operating Pressure	5000 psi (350 bar)
Rated Flow	19 gpm (70 l/min)
Cavity - Tooling (CA-10A-2N)	page CT.A.001.U
Line bodies	page MN1.A...
Weight	0.397 lbs (0.180 kg)
Fluids - Temperatures	page 7.01.040
Testing Conditions - Seals	page 7.01.040
Internal Leakage	page 7.01.040
Filtration : 25 μm nominal or better	page 7.01.050
Adjustment Torque at 145 psi (10 bar)	0.7 ft-lb (1 Nm)
Adjustment Torque at 5000 psi (350 bar)	7.4 ft-lb (10 Nm)
Mounting Position	unrestricted

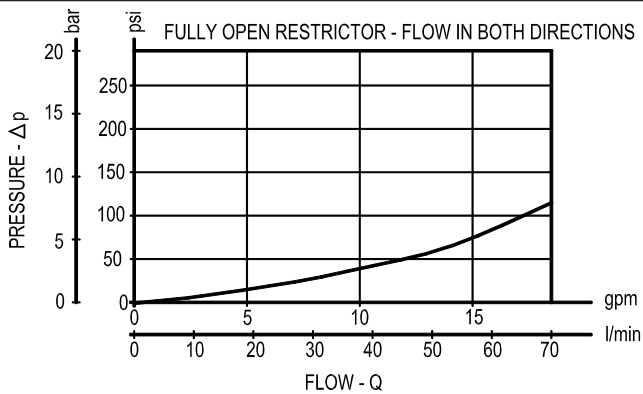

X ORDERING OPTIONS

03 Socket Screw

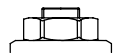

04 Handknob and Locknut

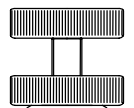

**FLOW CONTROL VALVES
CARTRIDGE RESTRICTORS
COMMON CAVITY**

ST-C-12A

SIZE 12

OD.21.01 - X - 89

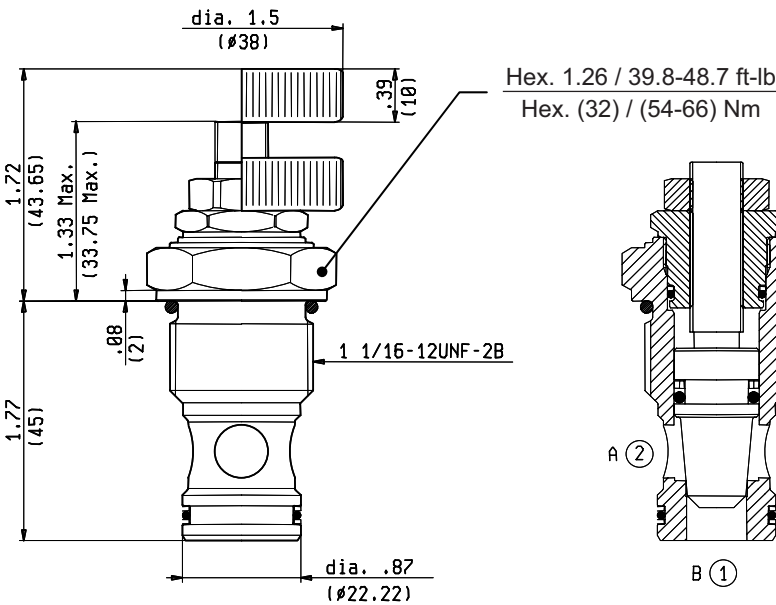

Inches
(mm)

TECHNICAL DATA

Maximum Operating Pressure	5000 psi (350 bar)
Rated Flow	39 gpm (150 l/min)
Cavity - Tooling (CA-12A-2N)	page CT.A.001.U
Line bodies	page MN1.A...
Weight	0.684 lbs (0.310 kg)
Fluids - Temperatures	page 7.01.040
Testing Conditions - Seals	page 7.01.040
Internal Leakage	page 7.01.040
Filtration : 25 µm nominal or better	page 7.01.050
Adjustment Torque at 145 psi (10 bar)	0.7 ft-lb (1 Nm)
Adjustment Torque at 5000 psi (350 bar)	13.3 ft-lb (18 Nm)
Mounting Position	unrestricted

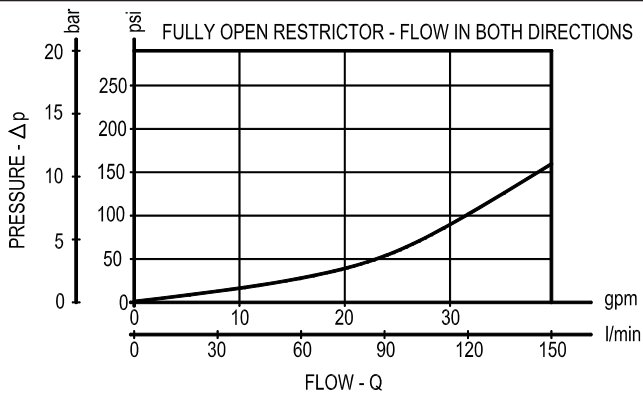

X ORDERING OPTIONS

03 Socket Screw

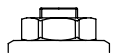

04 Handknob and Locknut

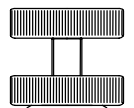

**CHECK, POPPET TYPE
COMMON CAVITY**

VUCN-16A

SIZE 16

04.31.25.00.27 - Z

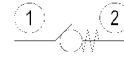
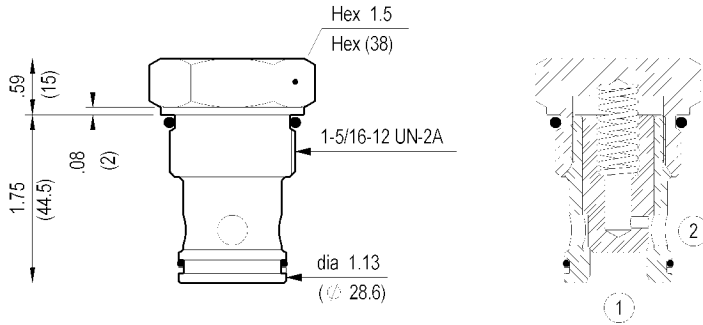

TECHNICAL DATA

Max. pressure:	5000 psi	(350 bar)
Max. flow:	53 gpm	(200 l/min)
Cavity : CA-16A-2N (see page CT.A.001.U)		
Line bodies : see page MN1.A...		
External seal kit : see page A11.012		
Installation torque :	80-90 ft-lb	(108-122 Nm)
Weight:	0.595 lbs	(0.270 Kg)

Inches
(mm)

When pressure at 1 rises above the spring bias pressure, the poppet is lifted and flow allowed from 1 to 2. The valve is closed (checked) from 2 to 1. Precision machining and hardening processes allow virtually leak-free performance in the checked condition.

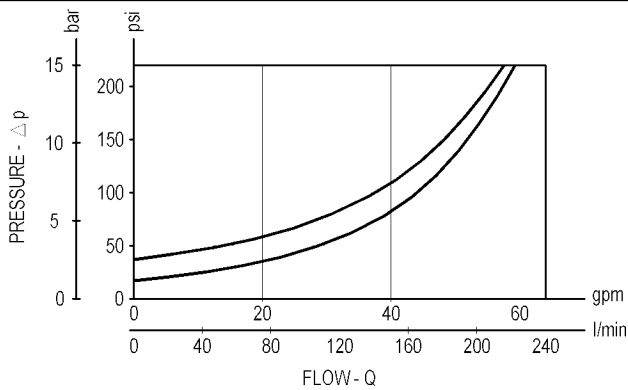

Z	SPRINGS				
	Cracking pressure psi (bar)				
00	15 (1)				
02	30 (2)				

Logic Elements	
VLST-10A	
VLST-16A	
VLST-20A	
VLSP-10A	
VLSP-16A	
VCSQ-16A	

**LOGIC ELEMENT, FLOW AND PRESSURE CONTROL
 WITH EXTERNAL PILOT
 COMMON CAVITY**

VLST-10A

SIZE 10

04.84.01 - X - 85 - Z

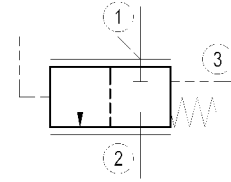
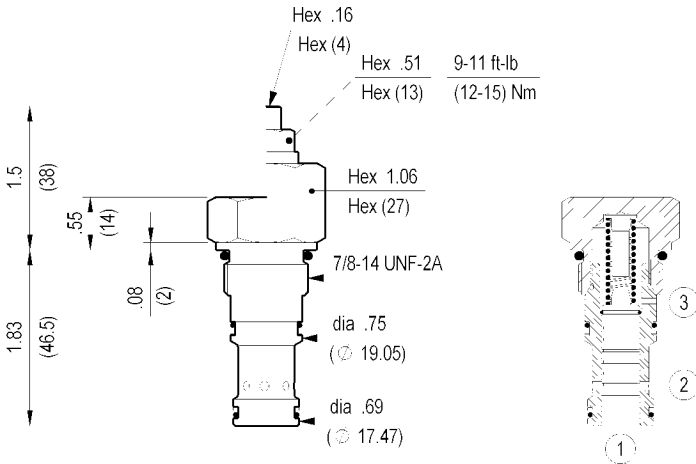

TECHNICAL DATA

Max. pressure:	5000 psi	(350 bar)
Max. flow:	16 gpm	(60 l/min)
Int. leakage ave. :	2900 psi 12 in ³ /min	(200 bar) (200 cm ³ /min)
Cavity : CA-10A-3C (see page CT.A.002.U)		
Line bodies : see page MN1.A...		
External seal kit : see page A11.011		
Installation torque :	30-35 ft-lb	(41-47 Nm)
Weight:	0.265 lbs	(0.120 Kg)

When pressure at 1 rises above the selected spring bias pressure against the spool, the valve shifts to allow flow from 1 to 2. Pilot pressure at 3 is additive to the spring bias pressure. The valve may be used in switching or compensation type applications.

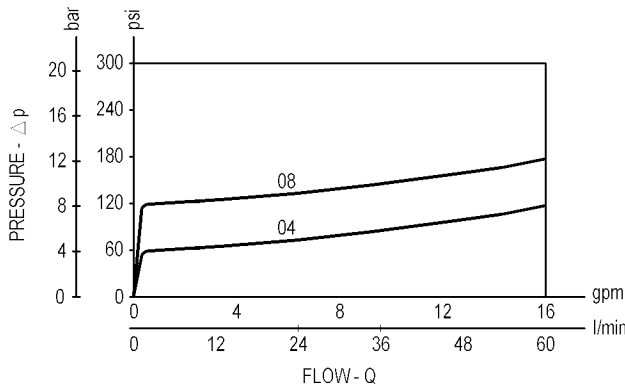

X ADJUSTMENTS

00	Fixed setting	
03	Leakproof hex. socket screw	

Z

SPRINGS

		Cracking press. psi (bar)	Press. increase psi / turn (bar/turn)	Standard setting psi (bar)		
X = 00	04	60 ±20% (4 ±20%)				
	08	115 ±15% (8 ±15%)				
X = 03	00	30-115 (2-8)	15 (1)	60 (4)		

**LOGIC ELEMENT, FLOW AND PRESSURE CONTROL
WITH EXTERNAL PILOT
COMMON CAVITY**

VLST-16A

SIZE 16

04.84.01 - X - 27 - Z

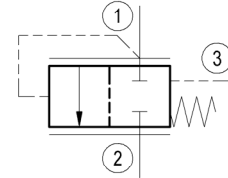
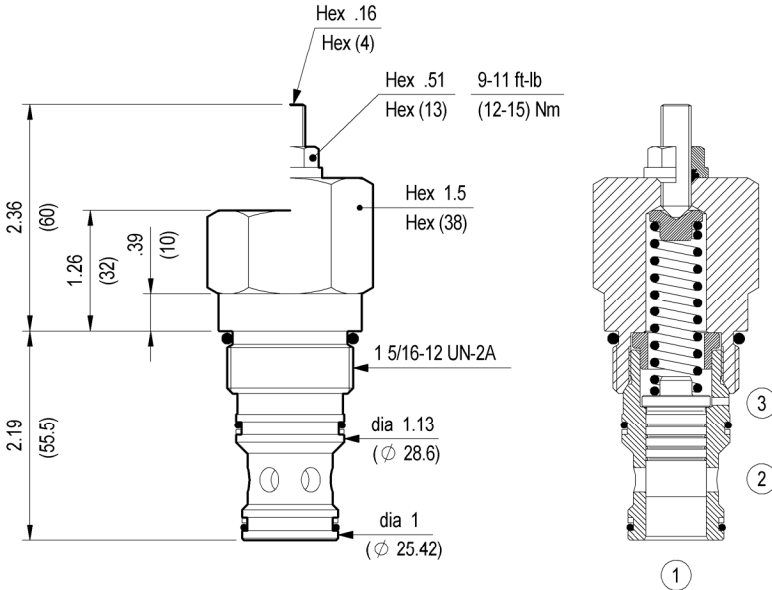

TECHNICAL DATA

Max. pressure:	5000 psi	(350 bar)
Max. flow:	53 gpm	(200 l/min)
Int. leakage ave. :	2900 psi 12 in ³ /min	(200 bar) (200 cm ³ /min)
Cavity : CA-16A-3C (see page CT.A.002.U)		
Line bodies : see page MN1.A...		
External seal kit : see page A11.012		
Installation torque :	80-90 ft-lb	(108-122 Nm)
Weight:	0.772 lbs	(0.350 Kg)

Inches
(mm)

When pressure at 1 rises above the selected spring bias pressure against the spool, the valve shifts to allow flow from 1 to 2. Pilot pressure at 3 is additive to the spring bias pressure. The valve may be used in switching or compensation type applications.

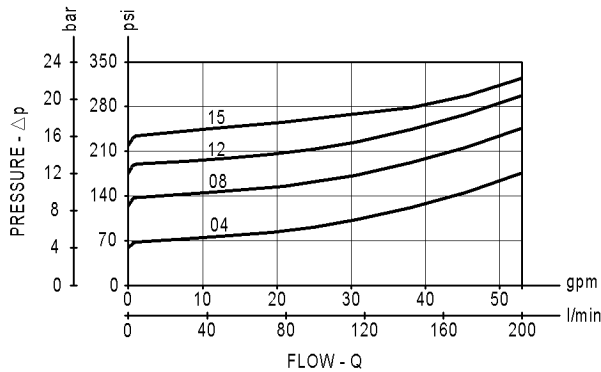

X ADJUSTMENTS

00	Fixed setting	
03	Leakproof hex. socket screw	

SPRINGS

Z	SPRINGS		
	Cracking press. psi (bar)	Press. increase psi / turn (bar/turn)	Standard setting psi (bar)
X = 00	04	60 ±20% (4 ±20%)	
	08	123 ±15% (8.5 ±15%)	
	12	175 ±10% (12 ±10%)	
	15	218 ±10% (15 ±10%)	
X = 03	00	60-175 (4-12)	22 (1.5)
			60 (4)

**LOGIC ELEMENT, FLOW AND PRESSURE CONTROL
 WITH EXTERNAL PILOT
 COMMON CAVITY**

VLST-20A

SIZE 20

04.84.01 - X - 58 - Z

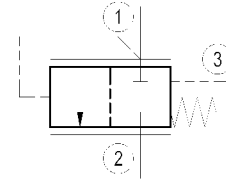
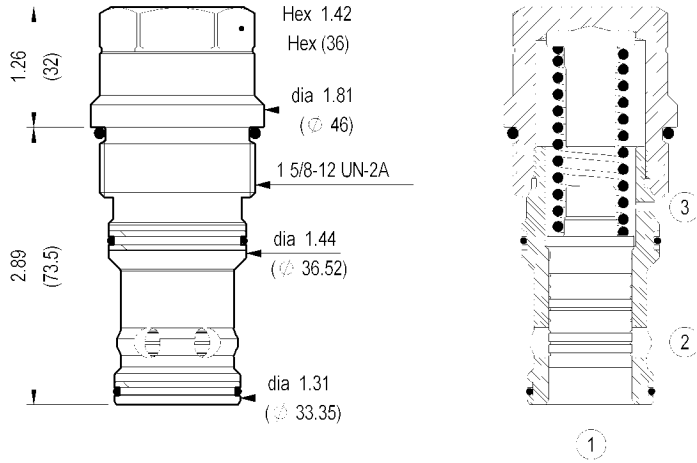

TECHNICAL DATA

Max. pressure:	5000 psi	(350 bar)
Max. flow:	95 gpm	(360 l/min)
Int. leakage ave. :	2900 psi 12 in ³ /min	(200 bar) (200 cm ³ /min)
Cavity : CA-20A-3C (see page CT.A.002.U)		
Line bodies : see page MN1.A...		
External seal kit : see page A11.012		
Installation torque :	95-110 ft-lb	(128-149 Nm)
Weight:	1.764 lbs	(0.800 Kg)

When pressure at 1 rises above the selected spring bias pressure against the spool, the valve shifts to allow flow from 1 to 2. Pilot pressure at 3 is additive to the spring bias pressure. The valve may be used in switching or compensation type applications.

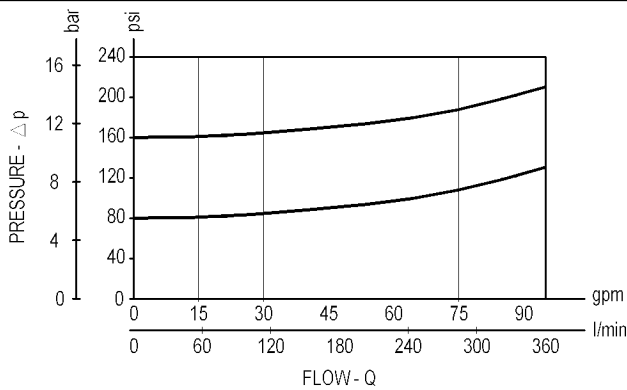

X ADJUSTMENTS

00	Fixed setting	
-----------	---------------	--

SPRINGS

Z	Cracking press. psi (bar)			
05	80 (5.5)			
11	167 (11.5)			

**LOGIC ELEMENT, FLOW AND PRESSURE CONTROL
WITH INTERNAL PILOT
COMMON CAVITY**

VLSP-10A

SIZE 10

04.84.03 - X - 85 - Z

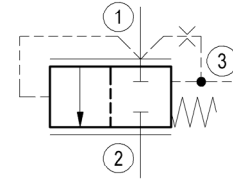
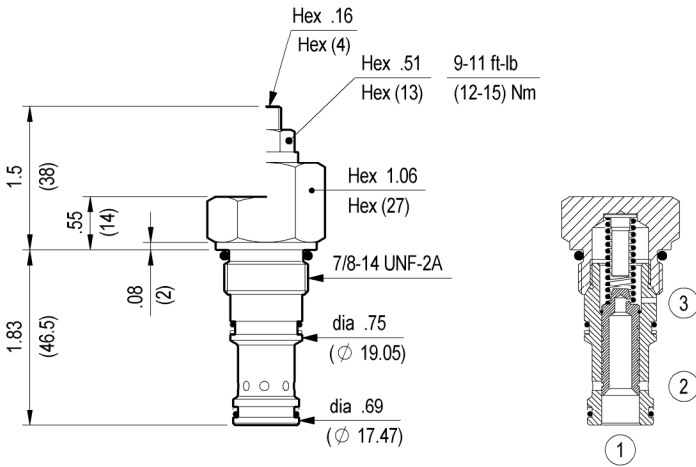

TECHNICAL DATA

Max. pressure:	5000 psi	(350 bar)
Max. flow:	16 gpm	(60 l/min)
Int. leakage ave. :	2900 psi 12 in ³ /min	(200 bar) (200 cm ³ /min)
Cavity : CA-10A-3C (see page CT.A.002.U)		
Line bodies : see page MN1.A...		
External seal kit : see page A11.011		
Installation torque :	30-35 ft-lb	(41-47 Nm)
Weight:	0.265 lbs	(0.120 Kg)
Standard internal orifice:	0.6 mm	

When pressure at 1 rises above the selected spring bias pressure against the spool, the valve shifts to allow flow from 1 to 2. The differential pressure between 1 and 3, across an internal orifice, is additive to the spring bias pressure. Note that flow, restricted by the internal orifice, can be transmitted from 3 to 1. The valve may be used in switching or compensation type applications.

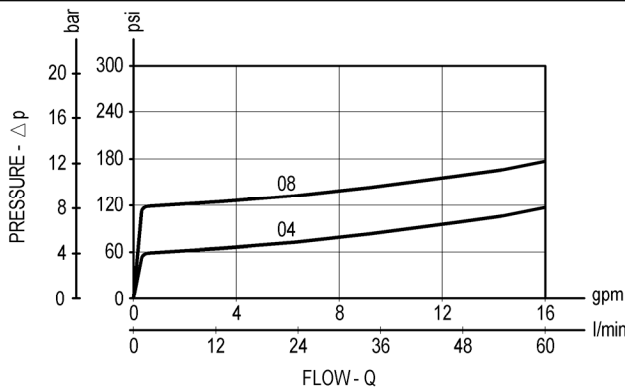

X ADJUSTMENTS

00	Fixed setting	
03	Leakproof hex. socket screw	

Z

SPRINGS

		Cracking press. psi (bar)	Press. increase psi / turn (bar/turn)	Standard setting psi (bar)		
X = 00	04	60 ±20% (4 ±20%)				
	08	115 ±15% (8 ±15%)				
X = 03	00	30-115 (2-8)	15 (1)	60 (4)		

**LOGIC ELEMENT, FLOW AND PRESSURE CONTROL
 WITH INTERNAL PILOT
 COMMON CAVITY**

VLSP-16A

SIZE 16

04.84.03 - X - 27 - Z

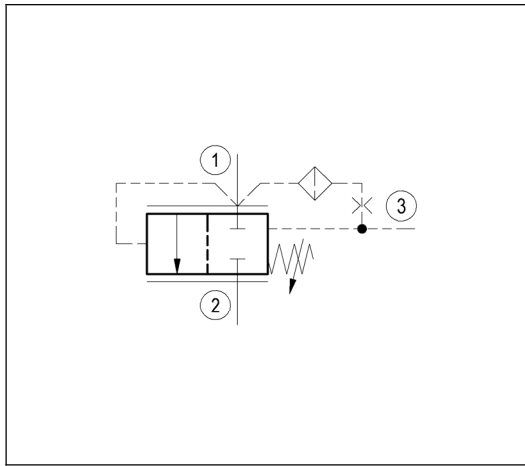
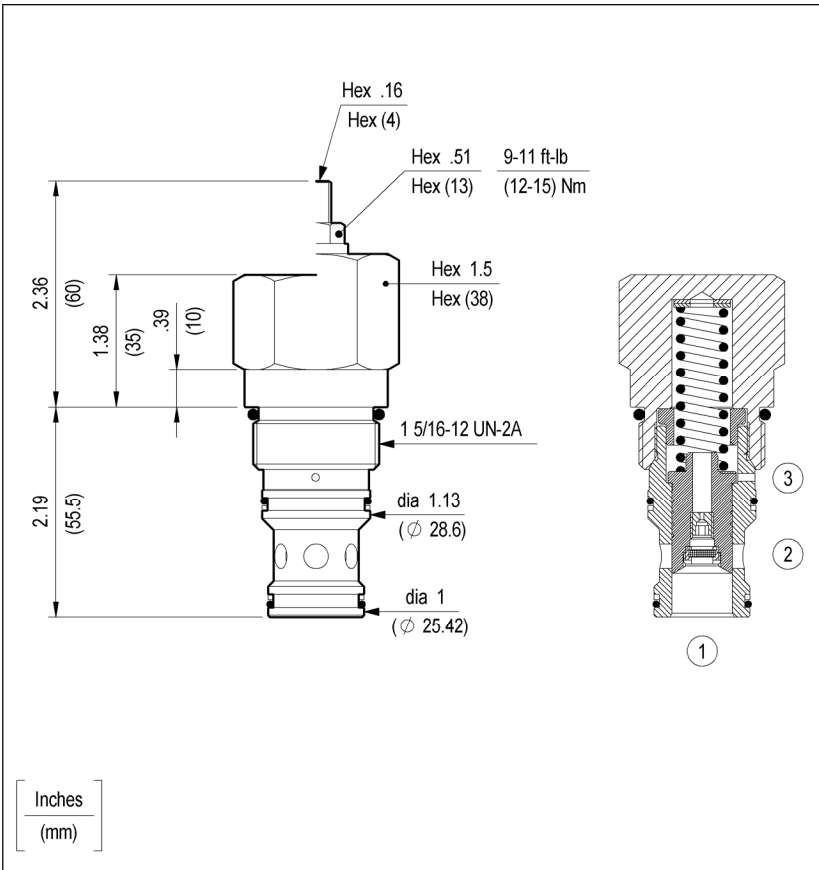

TECHNICAL DATA

Max. pressure:	5000 psi	(350 bar)
Max. flow:	53 gpm	(200 l/min)
Int. leakage ave. :	2900 psi	(200 bar)
	12 in ³ /min	(200 cm ³ /min)
Cavity : CA-16A-3C (see page CT.A.002.U)		
Line bodies : see page MN1.A...		
External seal kit : see page A11.012		
Installation torque :	80-90 ft-lb	(108-122 Nm)
Weight:	0.772 lbs	(0.350 Kg)
Standard internal orifice:	0.6 mm	

When pressure at 1 rises above the selected spring bias pressure against the spool, the valve shifts to allow flow from 1 to 2. The differential pressure between 1 and 3, across an internal orifice, is additive to the spring bias pressure. Note that flow, restricted by the internal orifice, can be transmitted from 3 to 1. The valve may be used in switching or compensation type applications.

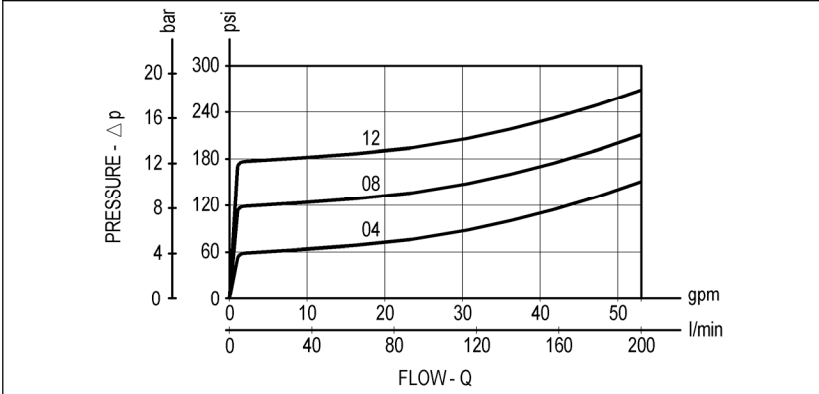

X	ADJUSTMENTS	
00	Fixed setting	
03	Leakproof hex. socket screw	

Z		SPRINGS			
		Cracking press. psi (bar)	Press. increase psi / turn (bar/turn)	Standard setting psi (bar)	
X = 00	04	60 ±20% (4 ±20%)			
	08	115 ±15% (8 ±15%)			
	12	175 ±10% (12 ±10%)			
X = 03	00	60-175 (4-12)	22 (1.5)	60 (4)	

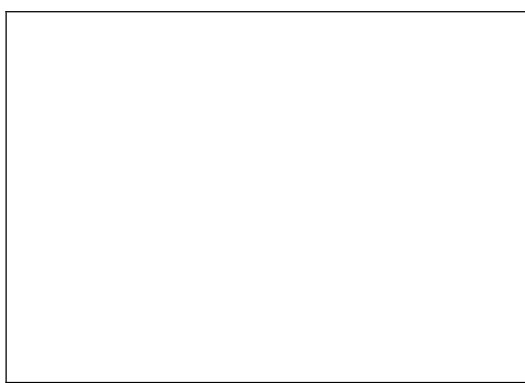

**LOGIC ELEMENT, PRESSURE COMPENSATOR
COMBINATION TYPE
COMMON CAVITY**



VCSQ-16A

SIZE 16

04.84.06 - X - 27 - Z

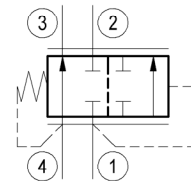
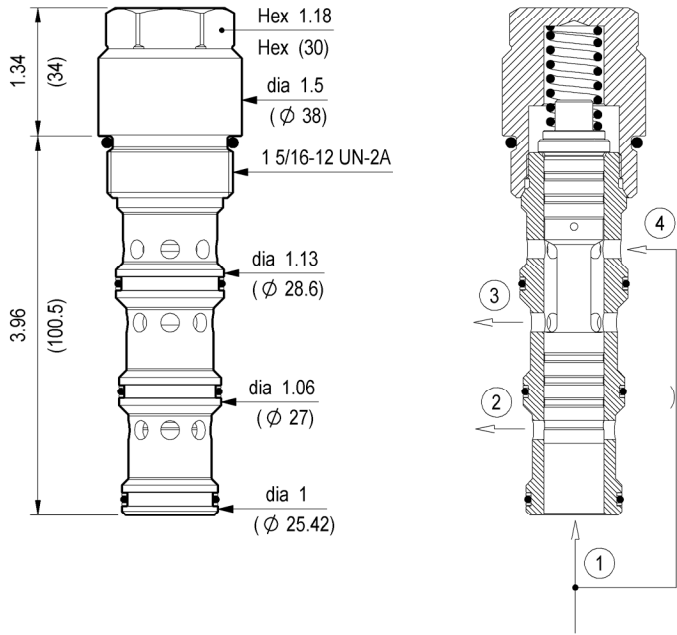

Inches
(mm)

Flow is normally allowed from 4 to 3. When pilot pressure at 1 rises above the combined pressure of the spring bias, plus pressure at 4, the valve shifts to block flow between 3 and 4, while diverting flow from 1 to 2. A constant pressure drop is maintained across a fixed (or variable) orifice upstream of 4 when installed and piloted per the diagram above. In this case, flow priority is given to 3, with flow in excess of the orifice differential requirement being by-passed to 2.

TECHNICAL DATA

Max. pressure:	5000 psi	(350 bar)
Max. inlet flow:	53 gpm	(200 l/min)
Max. priority flow:	32 gpm	(120 l/min)
Flow maintenance:	± 10%	
Cavity :	CA-16A-4N (see page A10.013)	
Line bodies :	see page A09.010 – A09.014	
External seal kit :	see page A11.012	
Installation torque :	80-90 ft-lb	(108-122 Nm)
Weight:	1.654 lbs	(0.750 Kg)

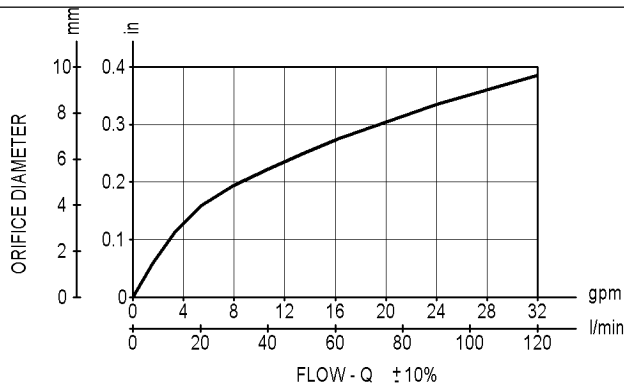

X ADJUSTMENTS

00	Fixed setting	

SPRINGS

Z	Cracking pressure			
	psi (bar)			
06	90 (6)			

Directional Valves, Mechanically Operated.	
VDS-10A	
VDP-32	

**DIRECTIONAL SPOOL TYPE,
DIRECT ACTING EXTERNAL PILOT EXTERNAL VENT
COMMON CAVITY**

VDSD-10A SIZE 10 04.77.22 - X - 85 - Z

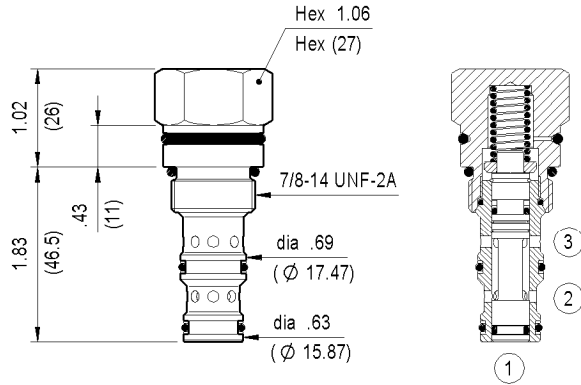

Inches
(mm)

Flow is allowed bi-directionally between 2 and 3 until pressure at 1 rises to overcome the spring bias against the spool. When this bias pressure is surpassed, the spool shifts, blocking flow at both 2 and 3. The spring chamber is sealed and vented to atmosphere, allowing consistent shifting with only spring bias pressure independent of conditions at 2 or 3.

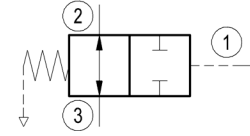

TECHNICAL DATA

Max. pressure:	5000 psi	(350 bar)
Max. flow:	13 gpm	(50 l/min)
Int. leakage ave. :	1.5 in ³ /min	(25 cm ³ /min)
Pilot displacement volume:	0.02 in ³	(0.28 cm ³)
Cavity : CA-10A-3N (see page CT.A.003.U)		
Line bodies : see page MN1.A...		
External seal kit : see page A11.011		
Installation torque :	30-35 ft-lb	(41-47 Nm)
Weight:	0.441 lbs	(0.200 Kg)

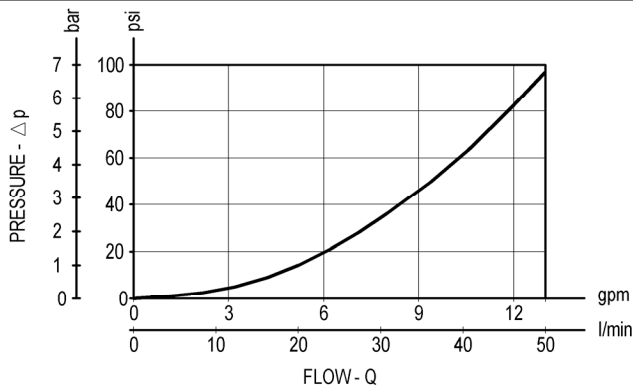

X O-RING ON PILOT PISTON

00	No O-Ring
10	With O-Ring

SPRINGS

Z	Setting psi (bar)			
05	80 ±20% (5.5 ±20%)			
11	167 ±10% (11.5 ±10%)			



**DIRECTIONAL CONTROL VALVES
HYDRAULIC AUTOMATIC SWITCHING
SPOOL 3-WAY 2-POSITION CARTRIDGE STYLE**



VDP-32

OD.71.01.51 - Z

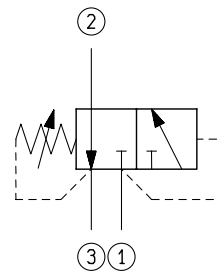
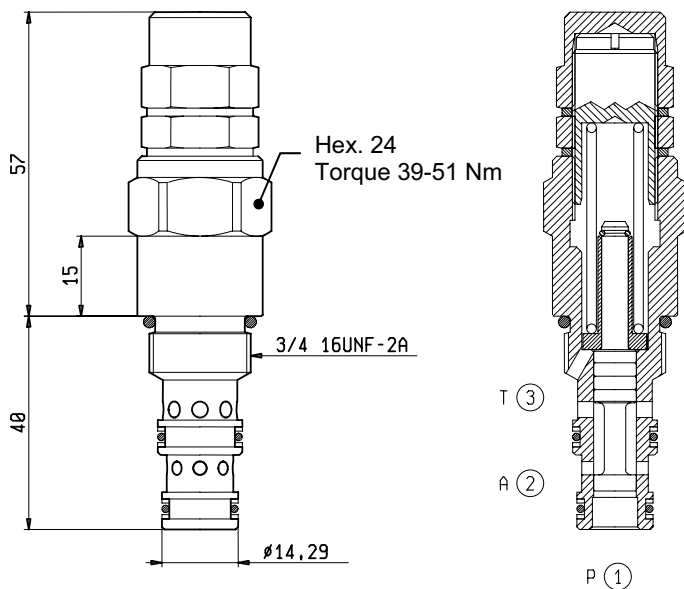

TECHNICAL DATA

Maximum Operating Pressure	315	bar
Rated Flow	30	l/min
Cavity - Tooling (051-E)	page 7.01.110	
Weight	0.195	kg
Fluids - Temperatures	page 7.01.040	
Testing Conditions - Seals	page 7.01.040	
Internal Leakage	page 7.01.050	
Filtration : 25 µm nominal or better	unrestricted	

Pressure settings different from standard have to be specified when ordering.

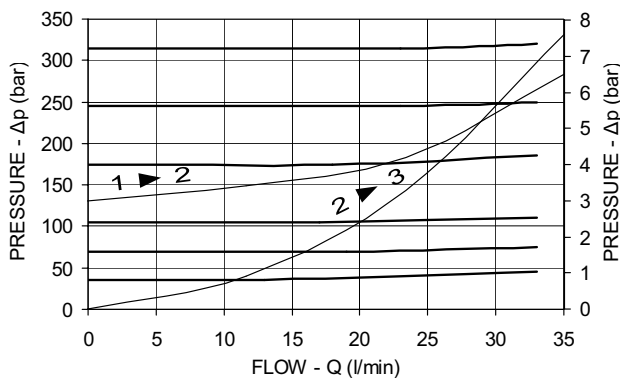

Z	SWITCHING PRESSURE bar				
	Adj. pressure range	Standard setting			
01	3-25	5			
02	20-60	35			
04	70-100	90			

Shuttle Valves	
VFC	
SELB-08A	

VFC

05.99.05.00 - Y

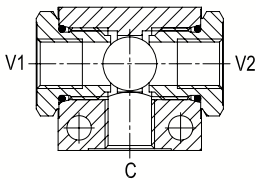
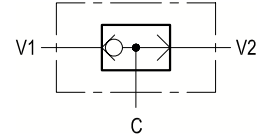
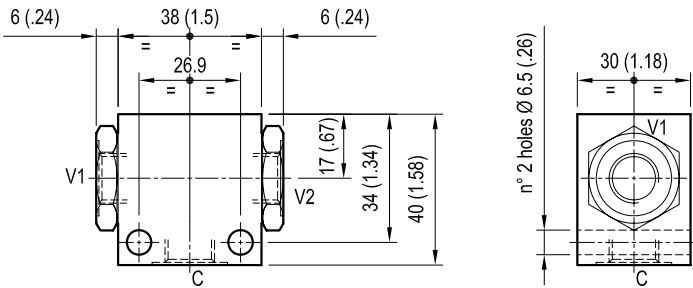

[mm (inches)]

Single ball shuttle valve with 3 ports for in-line plumbing: when the ports V1 and V2 are connected to 2 work lines, the valve delivers the highest of the 2 pressures to the common port C. The single ball allows for the decay of the pressure signal when both work ports drop to a lower pressure level.

TECHNICAL DATA

Operating pressure: up to 210 bar (3000 psi)

Max flow: 50 l/min (13 gpm)

Aluminium body
NOTE: aluminium bodies are often strong enough for operating pressures exceeding 210 bar (3000 psi), depending from the fatigue life expected in the specific application. If in doubt, consult our Service Network.

Weight: 0.17 kg (0.4 lbs)

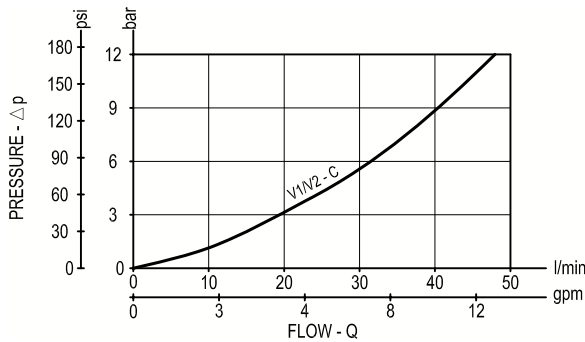

Y	PORT SIZE
	V1-V2-C
09	G 1/4

Solenoid Valves	
VED-8I-32-06-SE	
VED-8I-32-06-SI	
VED-8I-32-06-NC	
VED-8I-42-06-CA	
VED-8I-43-06-ABT	
VEI-8A-2A-06-NA-S-NSS	
VEI-8A-2A-06-NC-S-X-NSS	
VEI-8A-2A-09-NA-S-NSS	
VEI-8A-2A-09-NC-S-X-NSS	
VEI-8A-2A-10A-NA-S-NSS	
VEI-8I-2A-06-NC-S1-NSS, N9	
VEI-8A-2A-10A-NC-S-NSS	
VEI-8A-2A-10A-NC-S-X-NSS	
VEI-8A-2A-12-NA-S-NSS	
VEI-8A-2A-12-NC-S-X-NSS	
VEI-8A-2A-12A-NA-S-NSS	
VEI-8A-2T-06-NA-S-NSS	
VEI-8A-2T-06-NC-S-NSS	
VEI-8I-2A-06-NC-S-NSS	
VEI-8I-2A-06-NC-S1-NSS	
VEI-8I-2A-06-NC-S1-NSS, N9	

**DIRECTIONAL POPPET TYPE,
SHUTTLE
COMMON CAVITY**

SELB-08A

SIZE 08

04.94.05.00.56.00

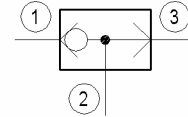
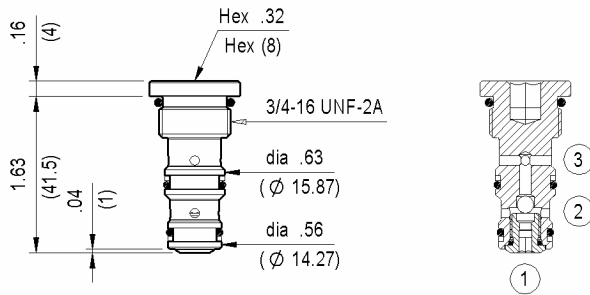

TECHNICAL DATA

Max. pressure: 5000 psi (350 bar)

Max. flow: see performance graph

Nominal size DN 3

Cavity : CA-08A-3N (see page CT.A.003.U)

Line bodies : see page MN1.A...

External seal kit : see page A11.011

Installation torque : 25-30 ft-lb (34-41 Nm)

Weight: 0.132 lbs (0.060 Kg)

Inches
(mm)

The single ball shuttle allows flow from the higher pressure of two work ports 1 and 3 to the 2 port.

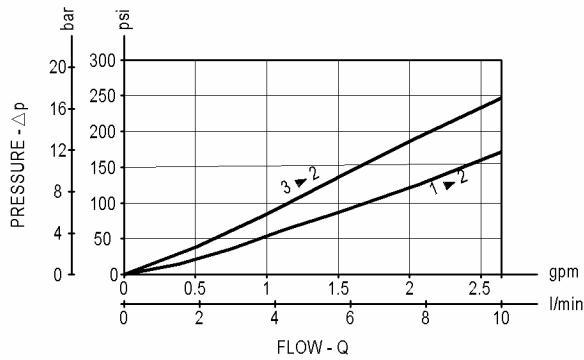

**SOLENOID OPERATED VALVES
 SPOOL 3-WAY 2-POSITION
 COMMON CAVITY**

VED-8I-32-06-SE

SIZE 08

OD.13.10.51 - Y - 00

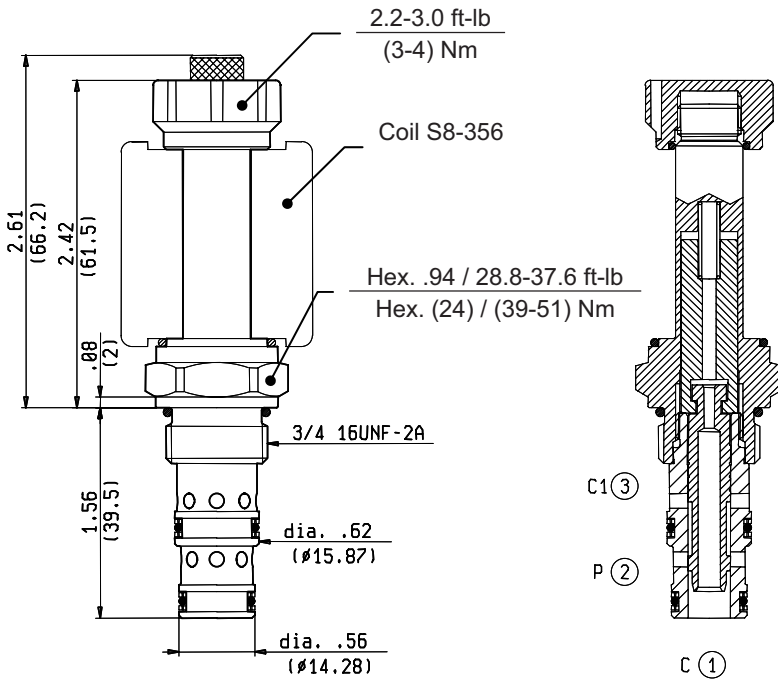

Inches
(mm)

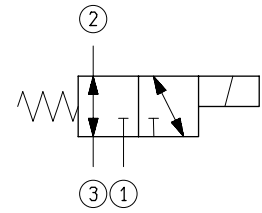

TECHNICAL DATA

Maximum Operating Pressure	3000 psi (210 bar)
Rated Flow	3 gpm (10 l/min)
Cavity - Tooling (CA-08A-3N)	page CT.A.003.U
Line bodies	page MN2.A...
Weight	0.286 lbs (0.130 kg)
Fluids - Temperatures	page 7.01.040
Testing Conditions - Seals	page 7.01.040
Internal Leakage at 3000 psi (210 bar) with 46 cSt oil	Max.2.5 in ³ /min (Max.40 cm ³ /min)
Filtration : 25 µm nominal or better	page 7.01.050
Minimum Voltage Required	90% of nominal
Coils must be ordered separately	page 1.71.042
Mounting Position	unrestricted

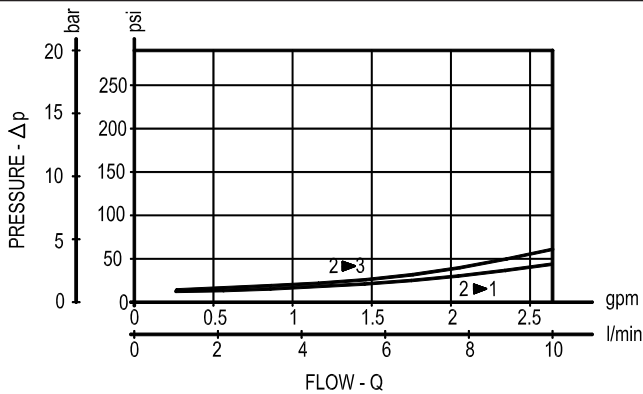

Y ORDERING OPTIONS

30 Standard

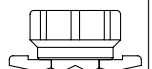

40 Knob Style Manual Override

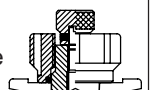

**SOLENOID OPERATED VALVES
 SPOOL 3-WAY 2-POSITION
 COMMON CAVITY**

VED-8I-32-06-SI

SIZE 08

OD.13.11.51 - Y - 00

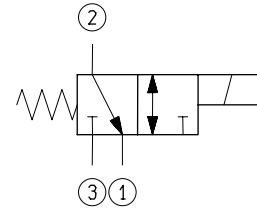
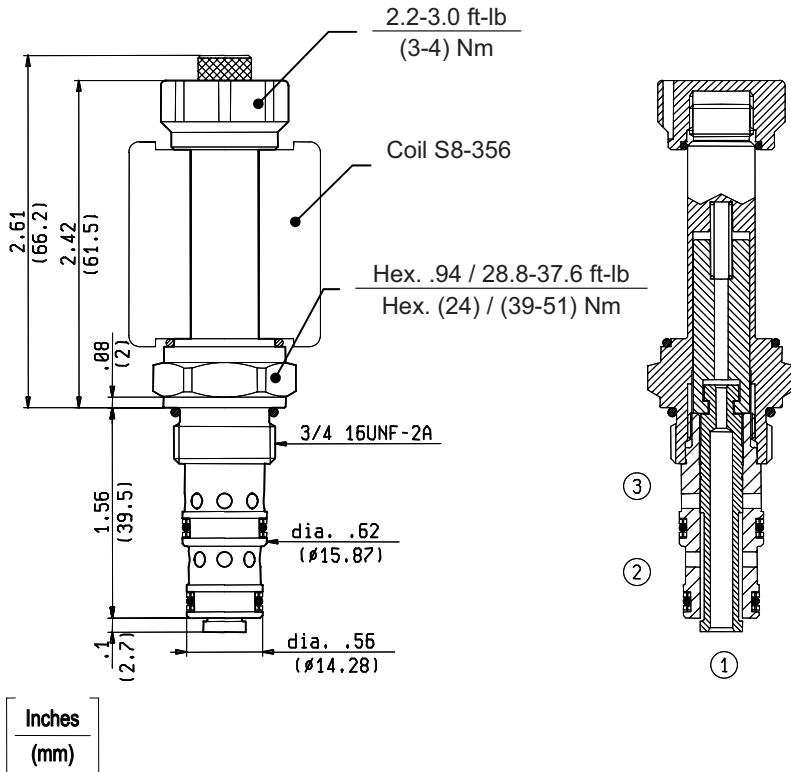

TECHNICAL DATA

Maximum Operating Pressure	3000 psi (210 bar)
Rated Flow	3 gpm (10 l/min)
Cavity - Tooling (CA-08A-3N)	page CT.A.003.U
Line bodies	page MN2.A...
Weight	0.286 lbs (0.130 kg)
Fluids - Temperatures	page 7.01.040
Testing Conditions - Seals	page 7.01.040
Internal Leakage(2 ▶ 3) at 210 bar with 46 cSt oil	Max.2.5 in ³ /min (Max.40 cm ³ /min)
Internal Leakage(2 ▶ 1) at 210 bar with 46 cSt oil	Max.9.8 in ³ /min (Max.160 cm ³ /min)
Filtration : 25 μm nominal or better	page 7.01.050
Minimum Voltage Required	90% of nominal
Coils must be ordered separately	page 1.71.042
Mounting Position	unrestricted

Port 1 can be pressurized but is not intended to be used as inlet port.

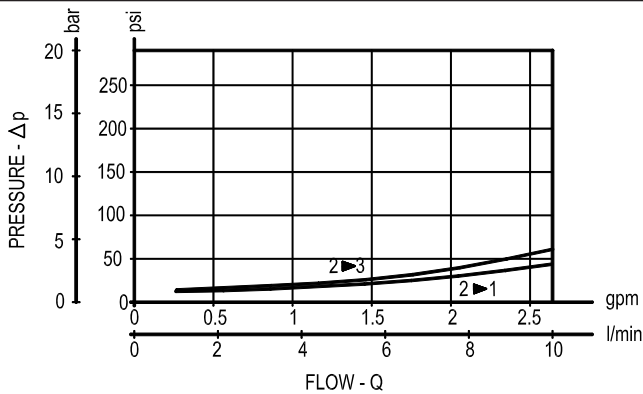

Y ORDERING OPTIONS

30 Standard

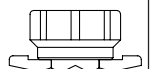

40 Knob Style Manual Override

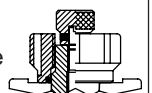

**SOLENOID OPERATED VALVES
 SPOOL 3-WAY 2-POSITION
 COMMON CAVITY**

VED-8I-32-06-NC

SIZE 08

OD.13.20.51 - Y - 00

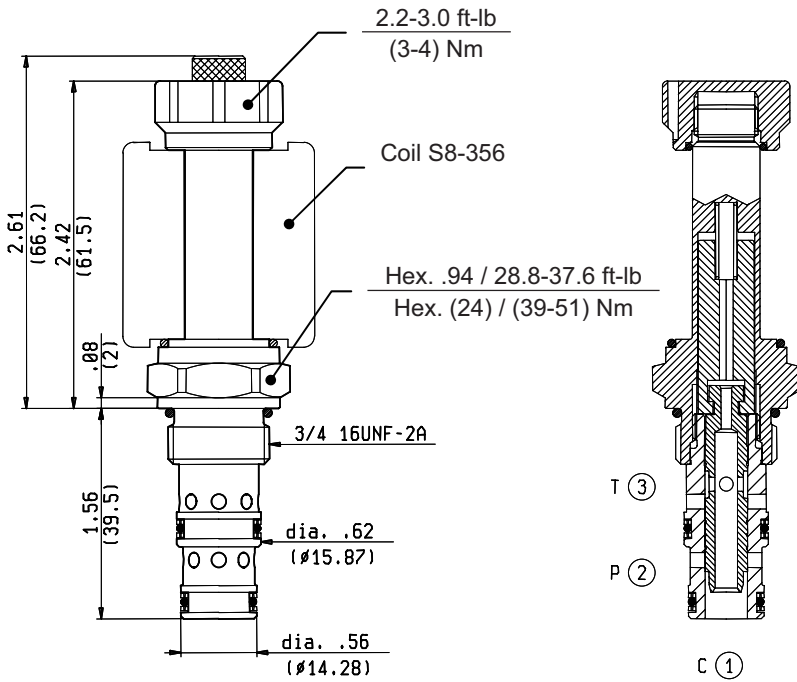

Inches
(mm)

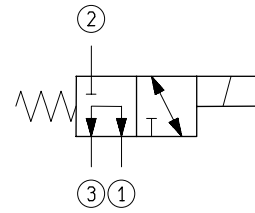

TECHNICAL DATA

Maximum Operating Pressure	3000 psi (210 bar)
Rated Flow	3 gpm (10 l/min)
Cavity - Tooling (CA-08A-3N)	page CT.A.003.U
Line bodies	page MN2.A...
Weight	0.286 lbs (0.130 kg)
Fluids - Temperatures	page 7.01.040
Testing Conditions - Seals	page 7.01.040
Internal Leakage at 3000 psi (210 bar) with 46 cSt oil	Max.2.5 in ³ /min (Max.40 cm ³ /min)
Filtration : 25 μm nominal or better	page 7.01.050
Minimum Voltage Required	90% of nominal
Coils must be ordered separately	page 1.71.042
Mounting Position	unrestricted

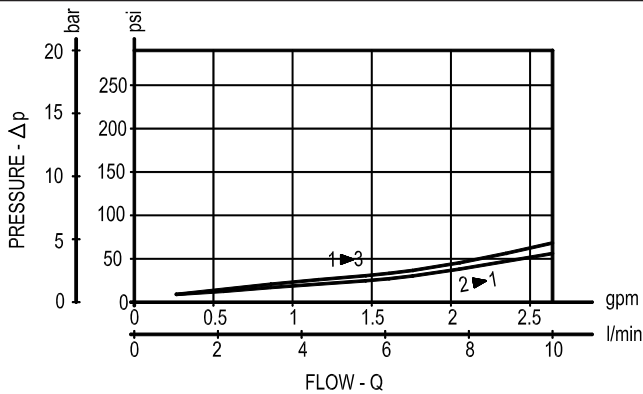

Y ORDERING OPTIONS

30 Standard

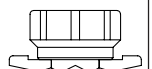

40 Knob Style Manual Override

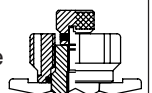

SOLENOID OPERATED VALVES
SPOOL 4-WAY 2-POSITION
COMMON CAVITY

VED-8I-42-06-CA

SIZE 08

OD.14.40.58 - Y - 00

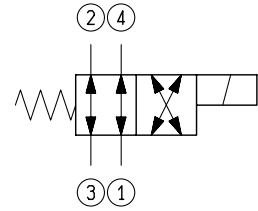
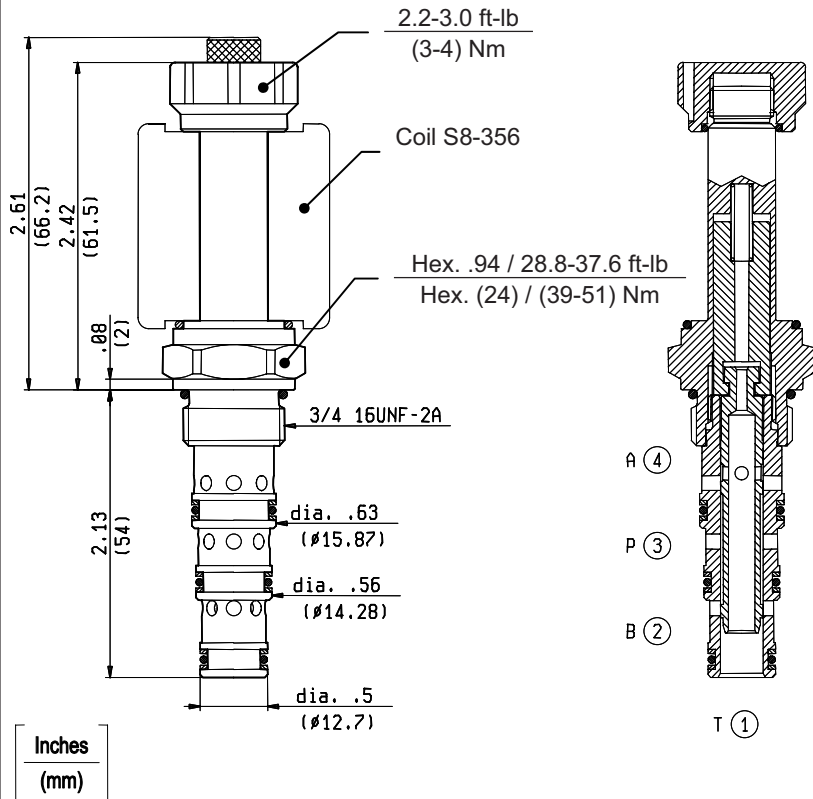

TECHNICAL DATA

Maximum Operating Pressure	3000 psi (210 bar)
Rated Flow	3 gpm (10 l/min)
Cavity - Tooling (CA-08A-4N)	page CT.A.004.U
Line bodies	page MN2.A...
Weight	0.286 lbs (0.130 kg)
Fluids - Temperatures	page 7.01.040
Testing Conditions - Seals	page 7.01.040
Internal Leakage at 3000 psi (210 bar) with 46 cSt oil	Max.2.5 in ³ /min (Max.40 cm ³ /min)
Filtration : 25 µm nominal or better	page 7.01.050
Minimum Voltage Required	90% of nominal
Coils must be ordered separately	page 1.71.042
Mounting Position	unrestricted

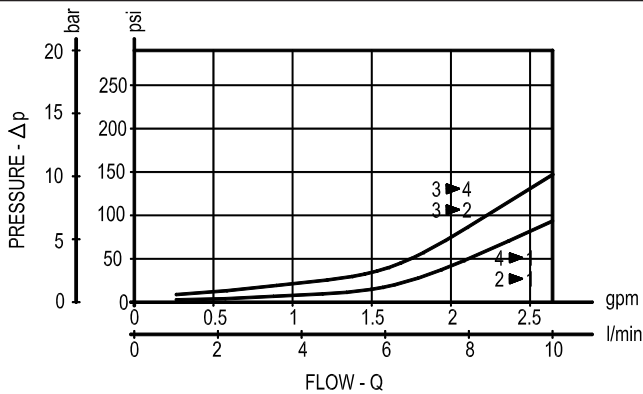

Y ORDERING OPTIONS

30 Standard

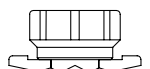

40 Knob Style Manual Override

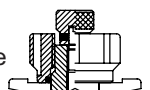

**SOLENOID OPERATED VALVES
 SPOOL 4-WAY 3-POSITION
 COMMON CAVITY**

VED-8I-43-06-ABT

SIZE 08

OD.14.32.58 - Y - 00

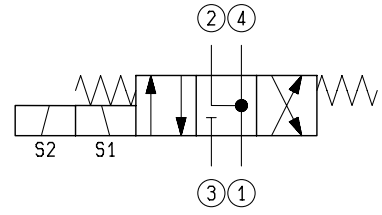
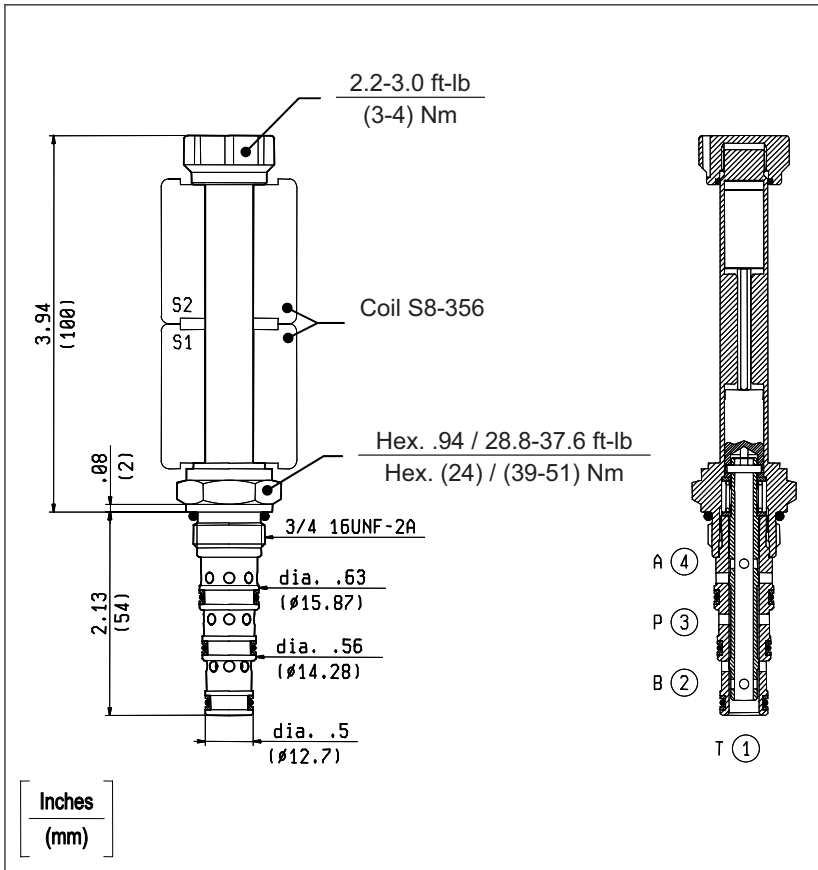

TECHNICAL DATA

Maximum Operating Pressure	3000 psi (210 bar)
Rated Flow	3 gpm (10 l/min)
Cavity - Tooling (CA-08A-4N)	page CT.A.004.U
Line bodies	page MN2.A...
Weight	0.397 lbs (0.180 kg)
Fluids - Temperatures	page 7.01.040
Testing Conditions - Seals	page 7.01.040
Internal Leakage at 3000 psi (210 bar) with 46 cSt oil	Max.7.3 in ³ /min (Max.120 cm ³ /min)
Filtration : 25 µm nominal or better	page 7.01.050
Minimum Voltage Required	90% of nominal
Coils must be ordered separately	page 1.71.042
Mounting Position	unrestricted

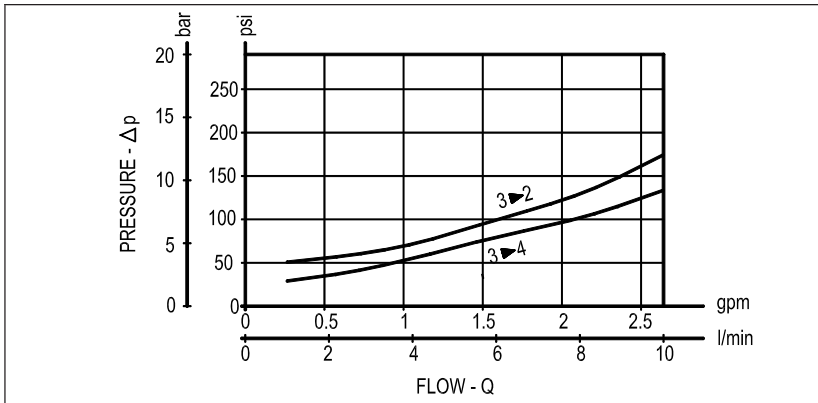

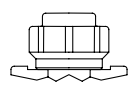
Y	ORDERING OPTIONS
44	Standard 

**SOLENOID OPERATED VALVES
 POPPET 2-WAY NORMALLY OPEN
 COMMON CAVITY**

VEI-8A-2A-06-NA-S-NSS

SIZE 08

OD.15.06.18 - Y - S0

PATENT PENDING

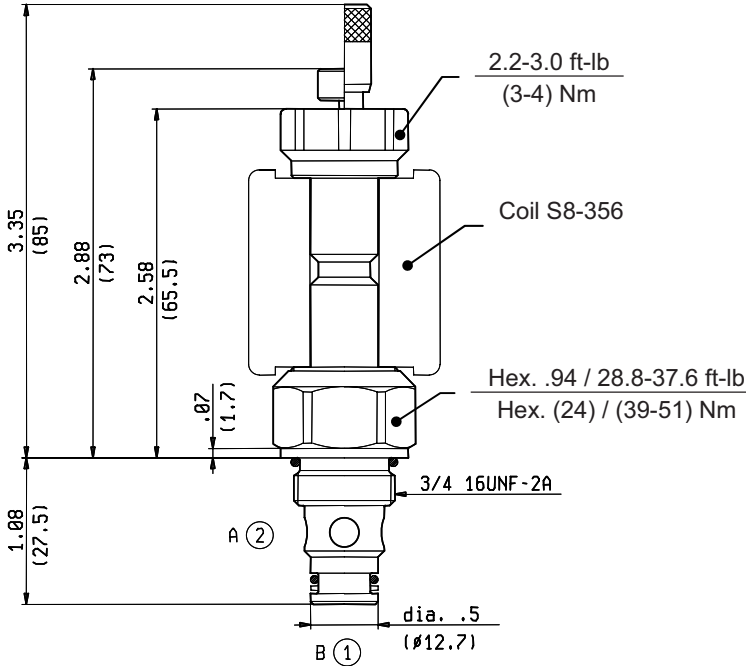

Inches
(mm)

TECHNICAL DATA

Maximum Operating Pressure	5000 psi (350 bar)
Fatigue Cycle Life at 5000 psi (350 bar) and 0.5 Hz (1 s ON - 1 s OFF)	10 million cycles
Rated Flow	11 gpm (40 l/min)
Cavity - Tooling (CA-08A-2N)	page CT.A.001.U
Line bodies	page MN2.A...
Weight	0.286 lbs (0.130 kg)
Fluids - Temperatures	page 7.01.040
Testing Conditions - Seals	page 7.01.040
Internal Leakage	page 7.01.040
Filtration : 25 µm nominal or better	page 7.01.050
Minimum Voltage Required	90% of nominal
Coils must be ordered separately	page 1.71.042
Mounting Position	unrestricted

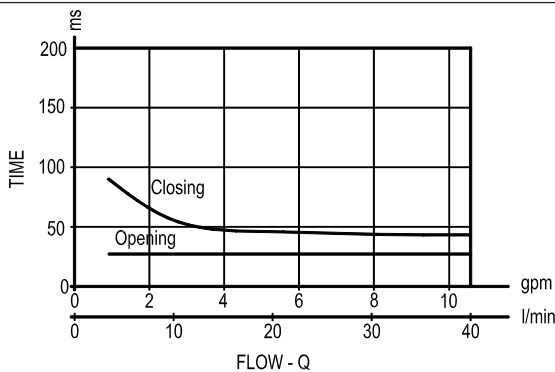
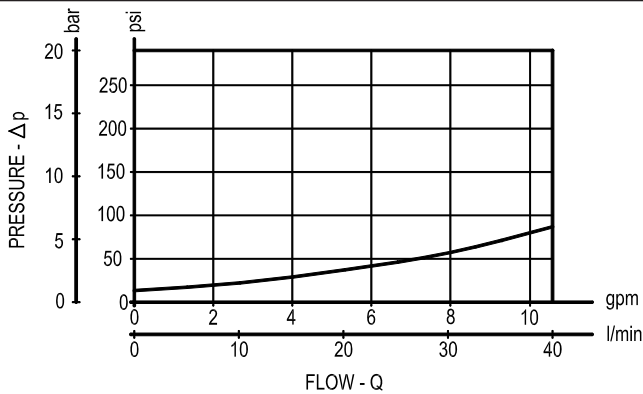

Y ORDERING OPTIONS

1A	Standard	
1B	Push Style Manual Override	
1C	Push and Twist Style Manual Override	

**SOLENOID OPERATED VALVES
POPPET 2-WAY NORMALLY CLOSED - EXTRA SPRING
SPECIAL CAVITY**



VEI-8A-2A-09-NC-S-X-NSS

017-E

OD.15.05.17 - Y - S8

PATENT PENDING

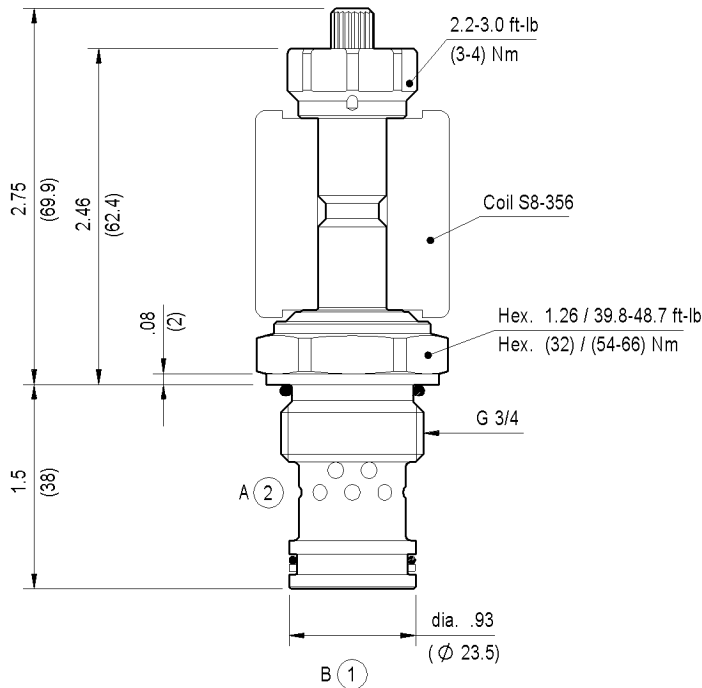

Inches
(mm)

TECHNICAL DATA

Maximum Operating Pressure	5000 psi (350 bar)
Fatigue Cycle Life at 5000 psi (350 bar) and 0.5 Hz (1 s ON - 1 s OFF)	10 million cycles
Rated Flow	19 gpm (70 l/min)
Cavity - Tooling (017-E)	page CT.S.005.U
Line bodies	page MN2.S...
Weight	0.485 lbs (0.220 kg)
Fluids - Temperatures	page 7.01.040
Testing Conditions - Seals	page 7.01.040
Internal Leakage	page 7.01.040
Filtration : 25 μ m nominal or better	page 7.01.050
Minimum Voltage Required	90% of nominal
Coils must be ordered separately	page 1.71.042
Mounting Position	unrestricted

The only difference between this valve and the standard model is a spring placed between pilot section and poppet. This design allows faster response times with very small flow or even virtually zero flow. A pressure of approximately 58 psi (4 bar) is required to open the main poppet.

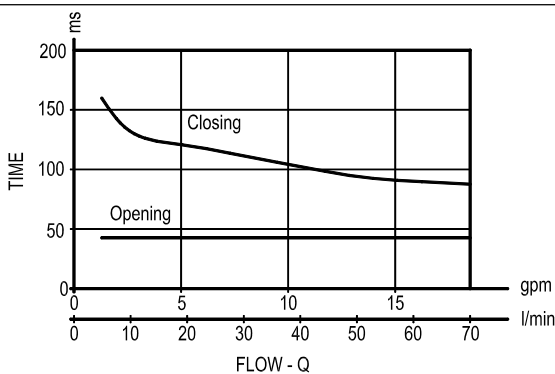
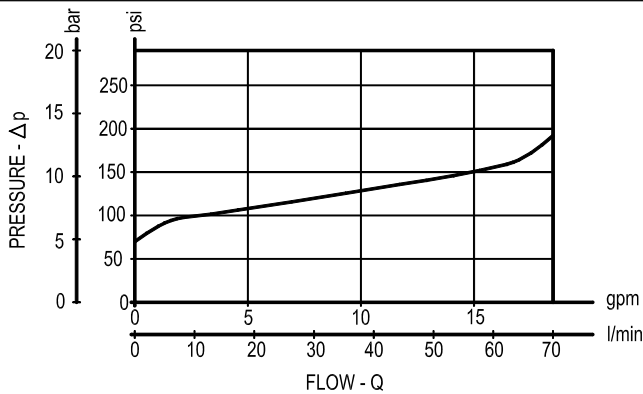

Y ORDERING OPTIONS

3A Standard

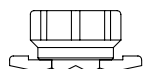

3D Knob Style Manual Override

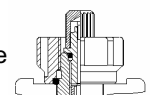

**SOLENOID OPERATED VALVES
 POPPET 2-WAY NORMALLY OPEN
 COMMON CAVITY**

VEI-8A-2A-10A-NA-S-NSS

SIZE 10

OD.15.06.36 - Y - S0

PATENT PENDING

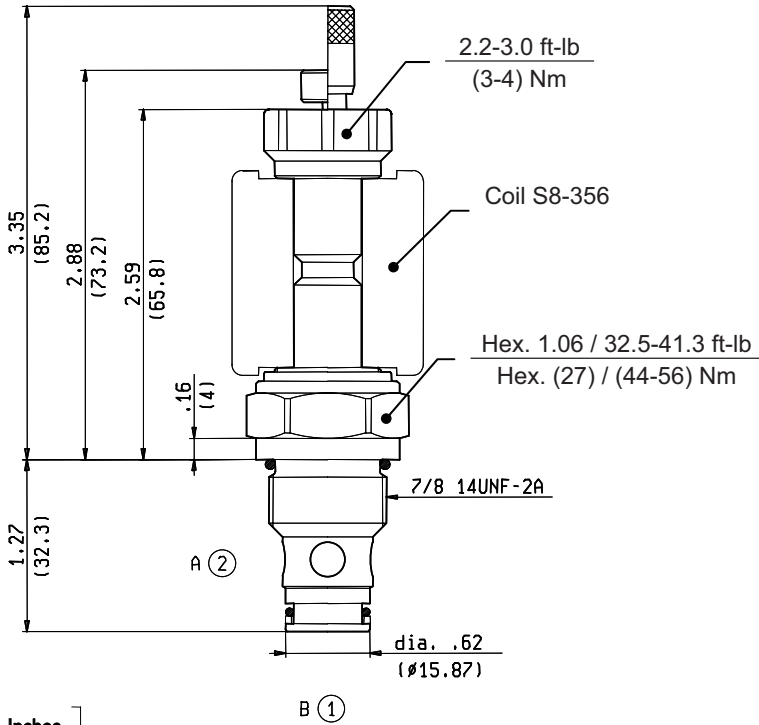

Inches
(mm)

TECHNICAL DATA

Maximum Operating Pressure	5000 psi (350 bar)
Fatigue Cycle Life at 5000 psi (350 bar) and 0.5 Hz (1 s ON - 1 s OFF)	10 million cycles
Rated Flow	19 gpm (70 l/min)
Cavity - Tooling (CA-10A-2N)	page CT.A.001.U
Line bodies	page MN1.A...
Weight	0.485 lbs (0.220 kg)
Fluids - Temperatures	page 7.01.040
Testing Conditions - Seals	page 7.01.040
Internal Leakage	page 7.01.040
Filtration : 25 µm nominal or better	page 7.01.050
Minimum Voltage Required	90% of nominal
Coils must be ordered separately	page 1.71.042
Mounting Position	unrestricted

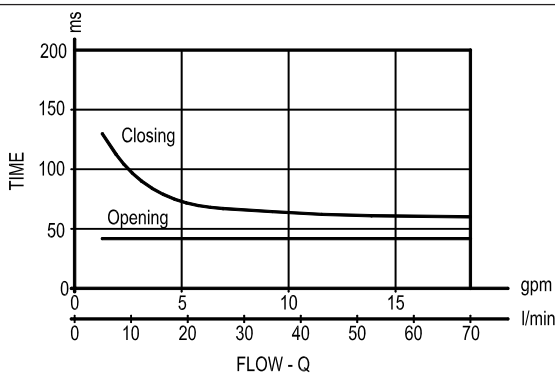
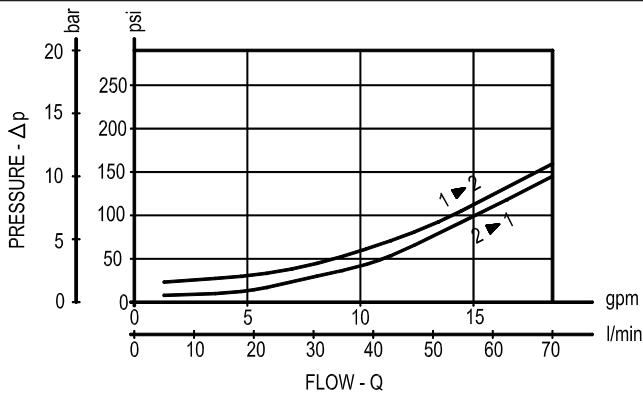

Y ORDERING OPTIONS

1A	Standard	
1B	Push Style Manual Override	
1C	Push and Twist Style Manual Override	

**SOLENOID OPERATED VALVES
POPPET 2-WAY NORMALLY CLOSED - EXTRA SPRING
SPECIAL CAVITY**



VEI-8A-2A-09-NC-S-X-NSS

017-E

OD.15.05.17 - Y - S8

PATENT PENDING

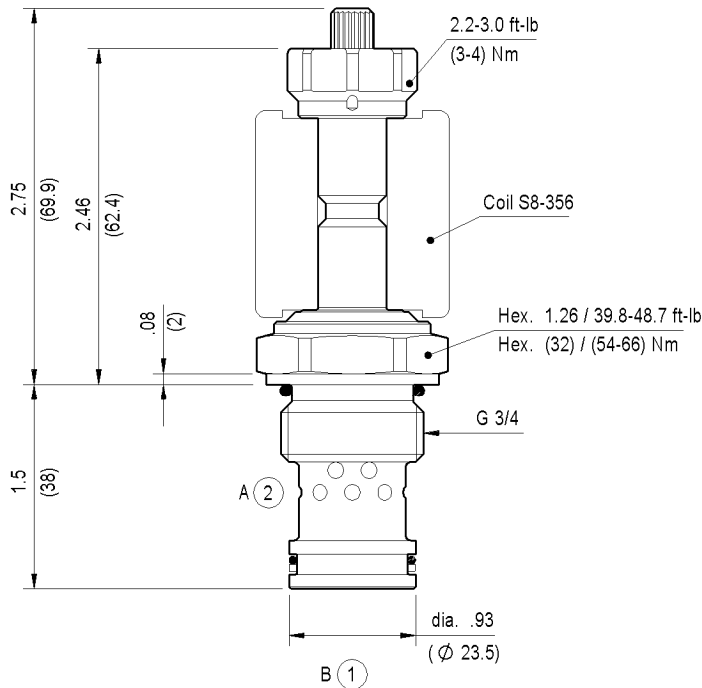

Inches
(mm)

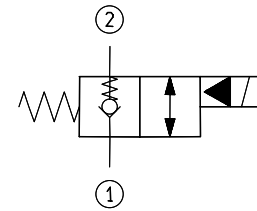

TECHNICAL DATA

Maximum Operating Pressure	5000 psi (350 bar)
Fatigue Cycle Life at 5000 psi (350 bar) and 0.5 Hz (1 s ON - 1 s OFF)	10 million cycles
Rated Flow	19 gpm (70 l/min)
Cavity - Tooling (017-E)	page CT.S.005.U
Line bodies	page MN2.S...
Weight	0.485 lbs (0.220 kg)
Fluids - Temperatures	page 7.01.040
Testing Conditions - Seals	page 7.01.040
Internal Leakage	page 7.01.040
Filtration : 25 μm nominal or better	page 7.01.050
Minimum Voltage Required	90% of nominal
Coils must be ordered separately	page 1.71.042
Mounting Position	unrestricted

The only difference between this valve and the standard model is a spring placed between pilot section and poppet. This design allows faster response times with very small flow or even virtually zero flow. A pressure of approximately 58 psi (4 bar) is required to open the main poppet.

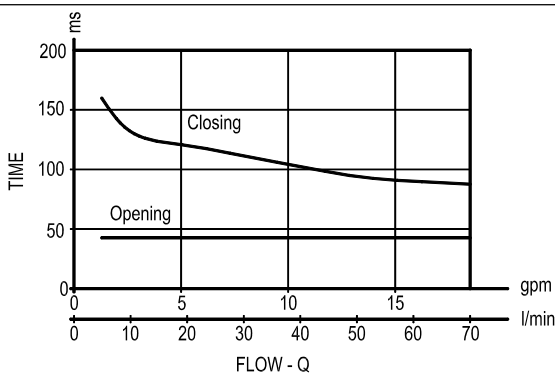
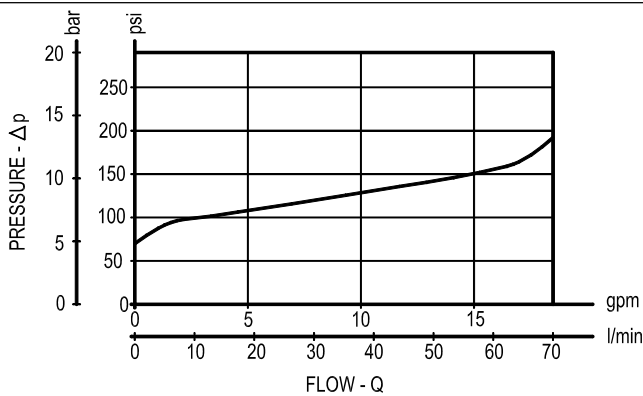

Y ORDERING OPTIONS

3A Standard

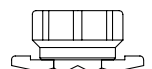

3D Knob Style Manual Override

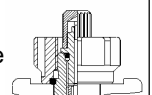

**SOLENOID OPERATED VALVES
 POPPET 2-WAY NORMALLY OPEN
 COMMON CAVITY**

VEI-8A-2A-10A-NA-S-NSS

SIZE 10

OD.15.06.36 - Y - S0

PATENT PENDING

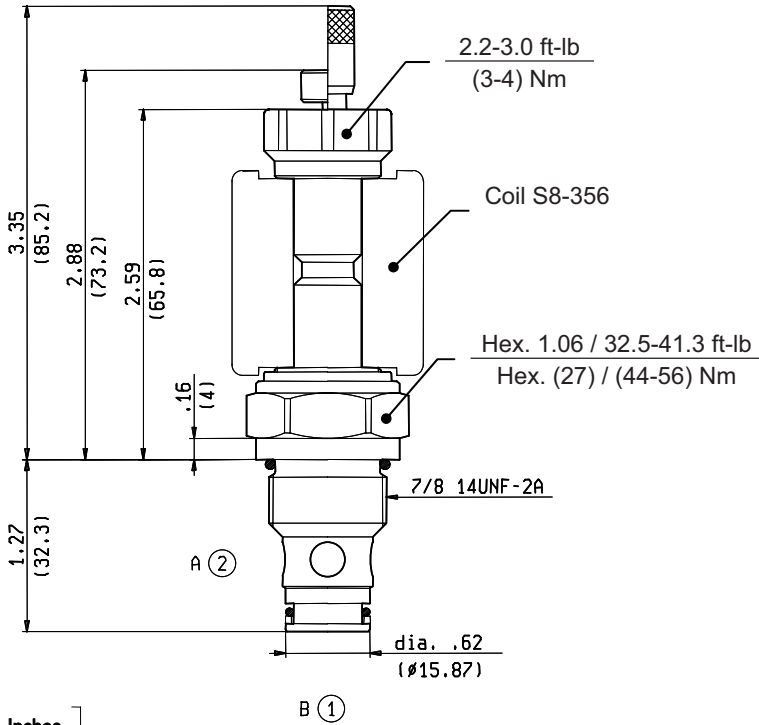

Inches
(mm)

TECHNICAL DATA

Maximum Operating Pressure	5000 psi (350 bar)
Fatigue Cycle Life at 5000 psi (350 bar) and 0.5 Hz (1 s ON - 1 s OFF)	10 million cycles
Rated Flow	19 gpm (70 l/min)
Cavity - Tooling (CA-10A-2N)	page CT.A.001.U
Line bodies	page MN1.A...
Weight	0.485 lbs (0.220 kg)
Fluids - Temperatures	page 7.01.040
Testing Conditions - Seals	page 7.01.040
Internal Leakage	page 7.01.040
Filtration : 25 µm nominal or better	page 7.01.050
Minimum Voltage Required	90% of nominal
Coils must be ordered separately	page 1.71.042
Mounting Position	unrestricted

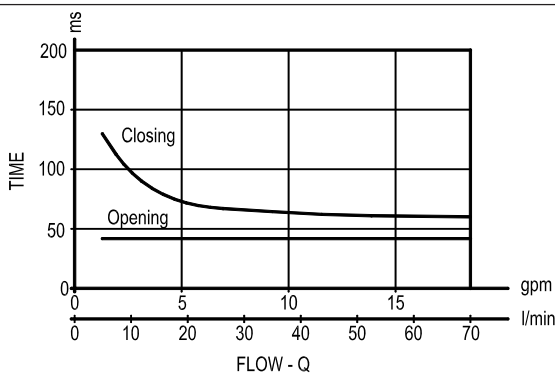
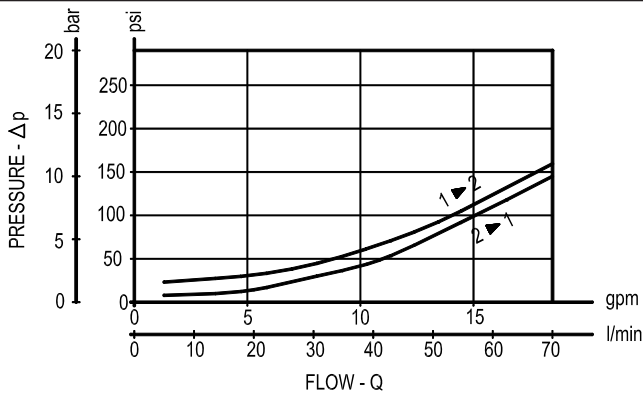

Y ORDERING OPTIONS

1A	Standard	
1B	Push Style Manual Override	
1C	Push and Twist Style Manual Override	

**SOLENOID OPERATED VALVES
POPPET 2-WAY NORMALLY CLOSED
COMMON CAVITY**



VEI-8A-2A-10A-NC-S-NSS

SIZE 10

OD.15.05.36 - Y - S0

PATENT PENDING

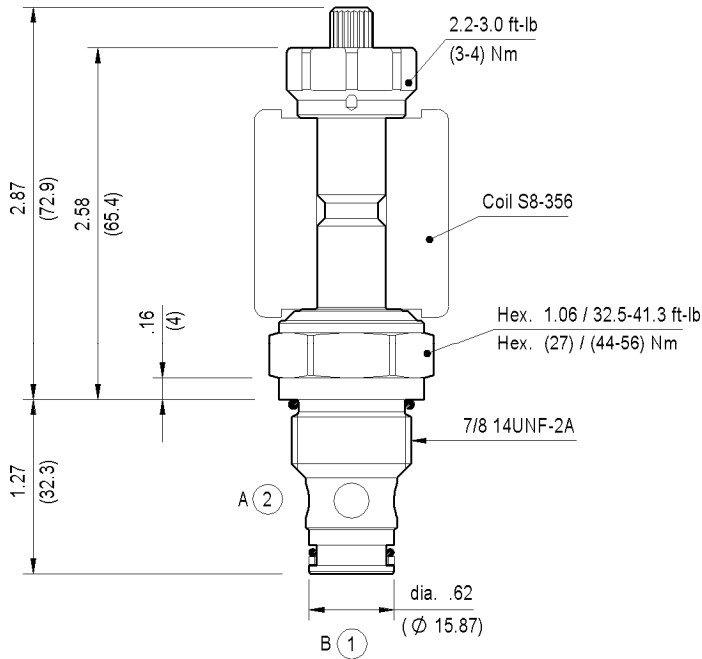

Inches
(mm)

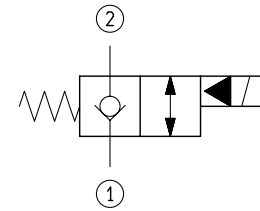

TECHNICAL DATA

Maximum Operating Pressure	5000 psi (350 bar)
Fatigue Cycle Life at 5000 psi (350 bar) and 0.5 Hz (1 s ON - 1 s OFF)	10 million cycles
Rated Flow	19 gpm (70 l/min)
Cavity - Tooling (CA-10A-2N)	page CT.A.001.U
Line bodies	page MN1.A...
Weight	0.485 lbs (0.220 kg)
Fluids - Temperatures	page 7.01.040
Testing Conditions - Seals	page 7.01.040
Internal Leakage	page 7.01.040
Filtration : 25 µm nominal or better	page 7.01.050
Minimum Voltage Required	90% of nominal
Coils must be ordered separately	page 1.71.042
Mounting Position	unrestricted

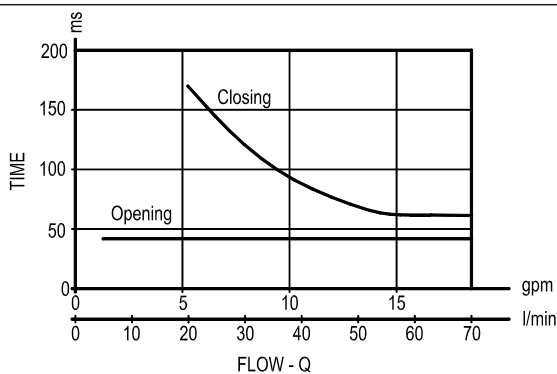
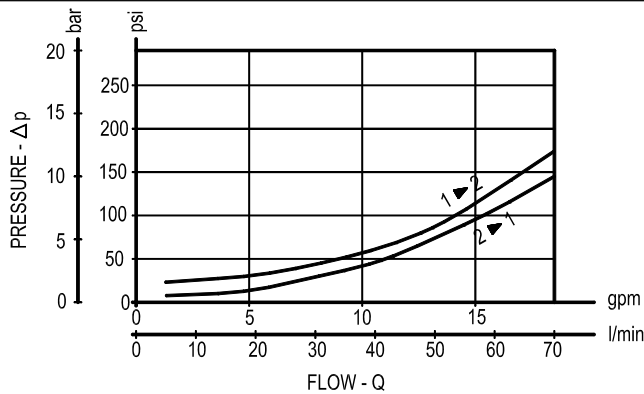

Y ORDERING OPTIONS

3A Standard

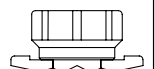

3D Knob Style Manual Override

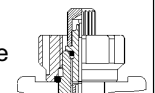

**SOLENOID OPERATED VALVES
POPPET 2-WAY NORMALLY CLOSED - EXTRA SPRING
COMMON CAVITY**



VEI-8A-2A-10A-NC-S-X-NSS SIZE 10 OD.15.05.36 - Y - S8

PATENT PENDING

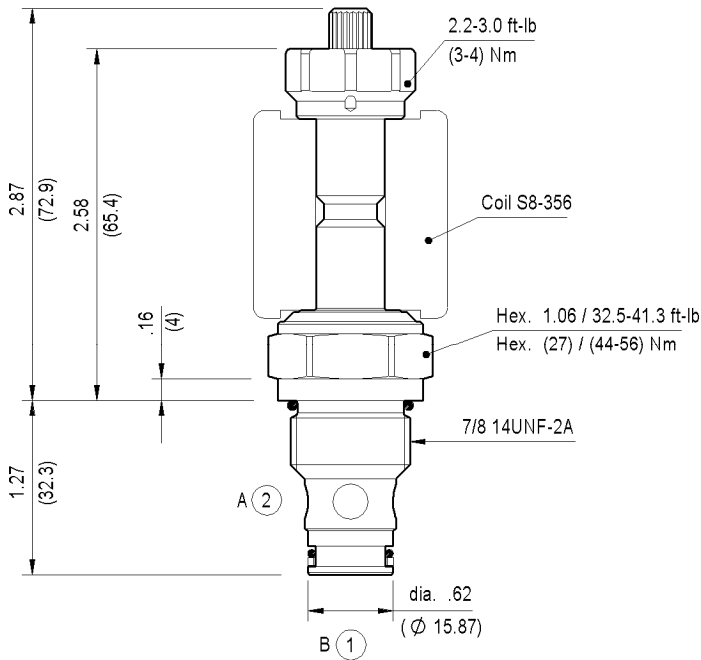

Inches
(mm)

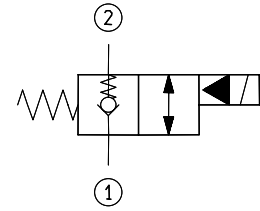

TECHNICAL DATA

Maximum Operating Pressure	5000 psi (350 bar)
Fatigue Cycle Life at 5000 psi (350 bar) and 0.5 Hz (1 s ON - 1 s OFF)	10 million cycles
Rated Flow	19 gpm (70 l/min)
Cavity - Tooling (CA-10A-2N)	page CT.A.001.U
Line bodies	page MN1.A...
Weight	0.485 lbs (0.220 kg)
Fluids - Temperatures	page 7.01.040
Testing Conditions - Seals	page 7.01.040
Internal Leakage	page 7.01.040
Filtration : 25 μ m nominal or better	page 7.01.050
Minimum Voltage Required	90% of nominal
Coils must be ordered separately	page 1.71.042
Mounting Position	unrestricted

The only difference between this valve and the standard model is a spring placed between pilot section and poppet. This design allows faster response times with very small flow or even virtually zero flow. A pressure of approximately 58 psi (4 bar) is required to open the main poppet.

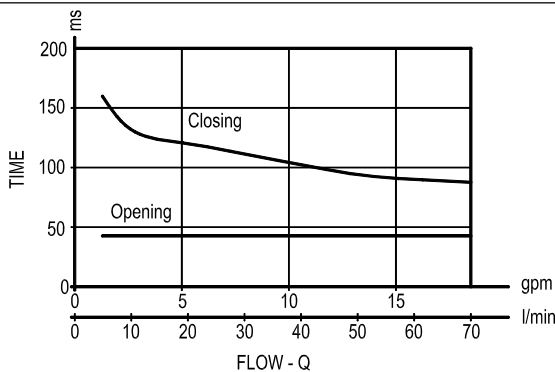
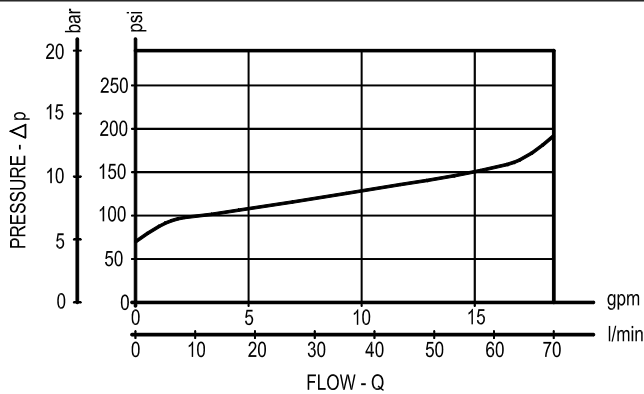

Y ORDERING OPTIONS

3A Standard

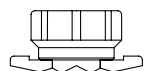

3D Knob Style Manual Override

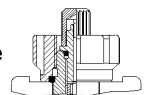

**SOLENOID OPERATED VALVES
POPPET 2-WAY NORMALLY OPEN
SPECIAL CAVITY**



VEI-8A-2A-12-NA-S-NSS

021-E

OD.15.06.21 - Y - S0

PATENT PENDING

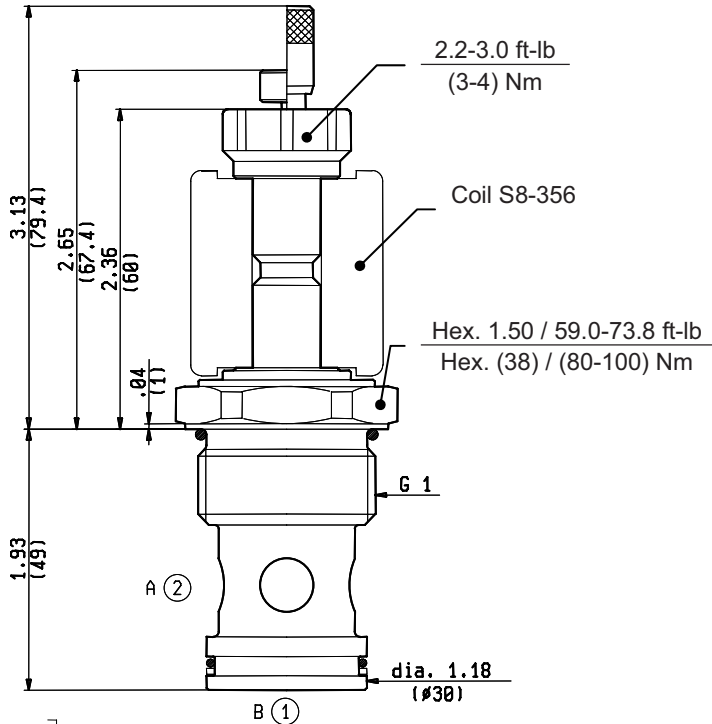

Inches
(mm)

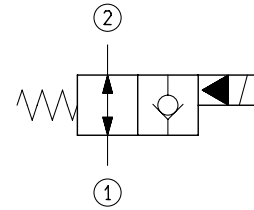

TECHNICAL DATA

Maximum Operating Pressure	5000 psi (350 bar)
Fatigue Cycle Life at 5000 psi (350 bar) and 0.5 Hz	10 million cycles (1 s ON - 1 s OFF)
Rated Flow	39 gpm (150 l/min)
Cavity - Tooling (021-E)	page CT.S.006.U
Line bodies	page MN2.S...
Weight	0.772 lbs (0.350 kg)
Fluids - Temperatures	page 7.01.040
Testing Conditions - Seals	page 7.01.040
Internal Leakage	page 7.01.040
Filtration : 25 µm nominal or better	page 7.01.050
Minimum Voltage Required	90% of nominal
Coils must be ordered separately	page 1.71.042
Mounting Position	unrestricted

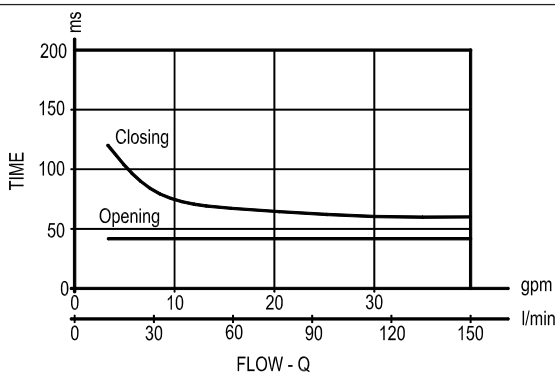
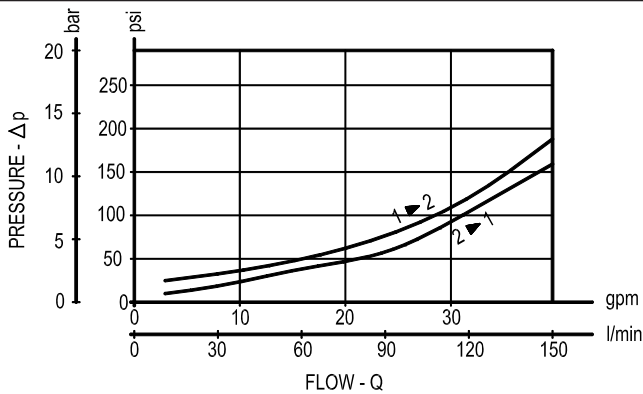

Y ORDERING OPTIONS

1A	Standard	
1B	Push Style Manual Override	
1C	Push and Twist Style Manual Override	

**SOLENOID OPERATED VALVES
POPPET 2-WAY NORMALLY CLOSED - EXTRA SPRING
SPECIAL CAVITY**



VEI-8A-2A-12-NC-S-X-NSS 021-E OD.15.05.21 - Y - S8

PATENT PENDING

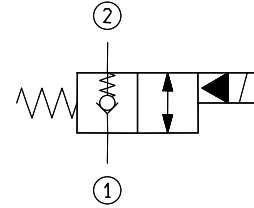
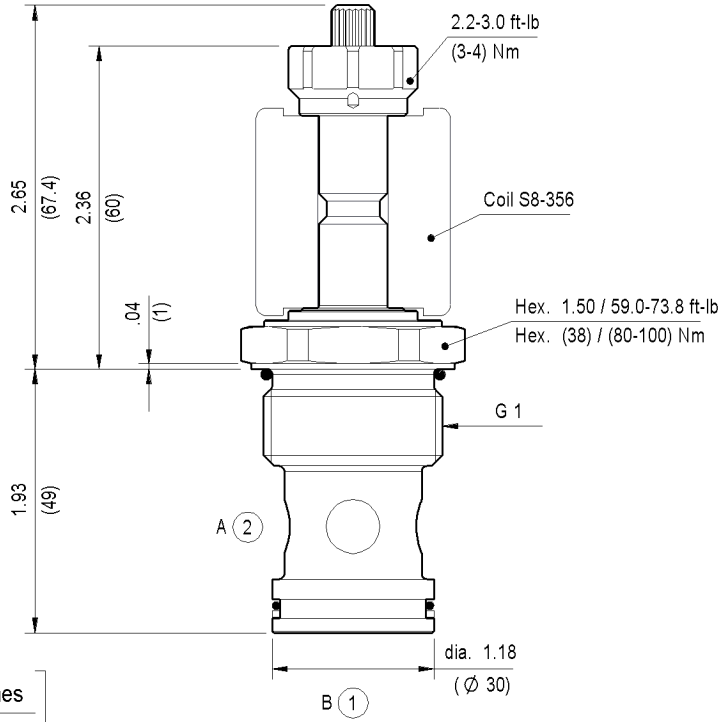

TECHNICAL DATA

Maximum Operating Pressure	5000 psi (350 bar)
Fatigue Cycle Life at 5000 psi (350 bar) and 0.5 Hz (1 s ON - 1 s OFF)	10 million cycles
Rated Flow	39 gpm (150 l/min)
Cavity - Tooling (021-E)	page CT.S.006.U
Line bodies	page MN2.S...
Weight	0.772 lbs (0.350 kg)
Fluids - Temperatures	page 7.01.040
Testing Conditions - Seals	page 7.01.040
Internal Leakage	page 7.01.040
Filtration : 25 µm nominal or better	page 7.01.050
Minimum Voltage Required	90% of nominal
Coils must be ordered separately	page 1.71.042
Mounting Position	unrestricted

The only difference between this valve and the standard model is a spring placed between pilot section and poppet. This design allows faster response times with very small flow or even virtually zero flow. A pressure of approximately 44 psi (3 bar) is required to open the main poppet.

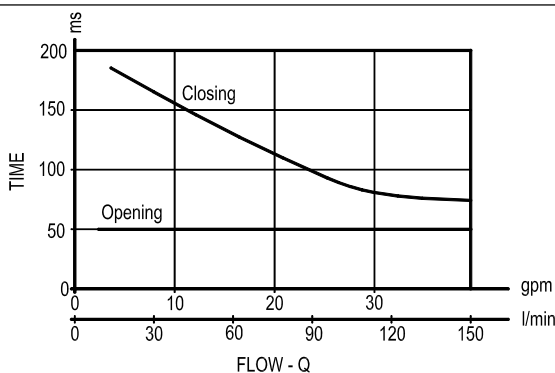
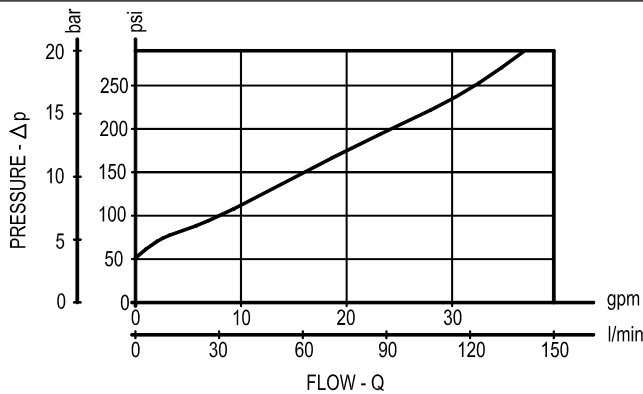

Y ORDERING OPTIONS

3A Standard

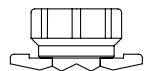

3D Knob Style Manual Override

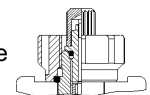

**SOLENOID OPERATED VALVES
 POPPET 2-WAY NORMALLY OPEN
 COMMON CAVITY**

VEI-8A-2A-12A-NA-S-NSS

SIZE 12

OD.15.06.89 - Y - S0

PATENT PENDING

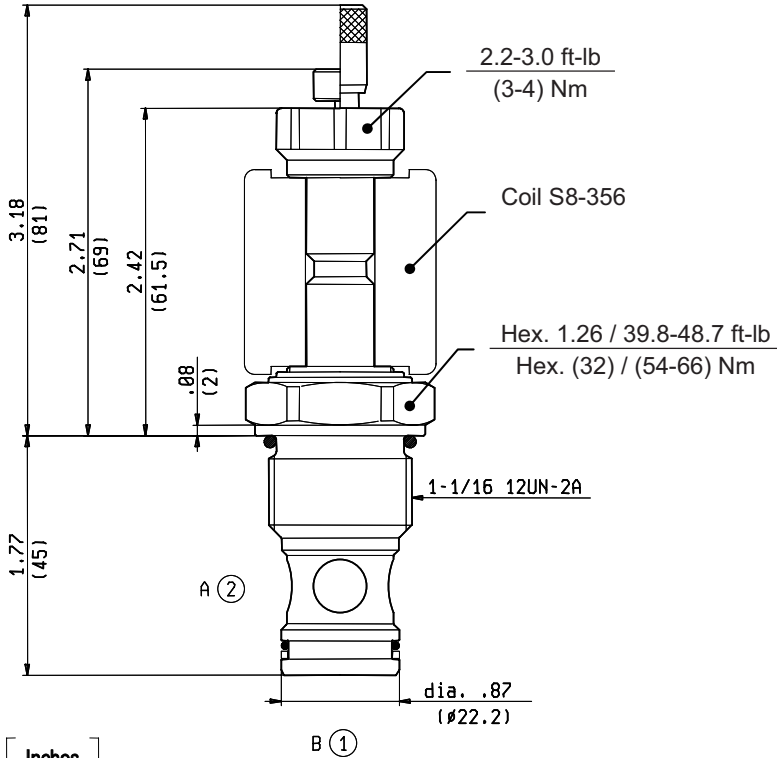

Inches
(mm)

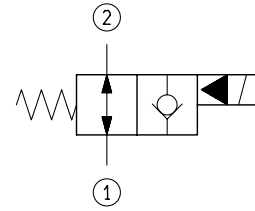

TECHNICAL DATA

Maximum Operating Pressure	5000 psi (350 bar)
Fatigue Cycle Life at 5000 psi (350 bar) and 0.5 Hz (1 s ON - 1 s OFF)	10 million cycles
Rated Flow	39 gpm (150 l/min)
Cavity - Tooling (CA-12A-2N)	page CT.A.001.U
Line bodies	page MN1.A...
Weight	0.772 lbs (0.350 kg)
Fluids - Temperatures	page 7.01.040
Testing Conditions - Seals	page 7.01.040
Internal Leakage	page 7.01.040
Filtration : 25 µm nominal or better	page 7.01.050
Minimum Voltage Required	90% of nominal
Coils must be ordered separately	page 1.71.042
Mounting Position	unrestricted

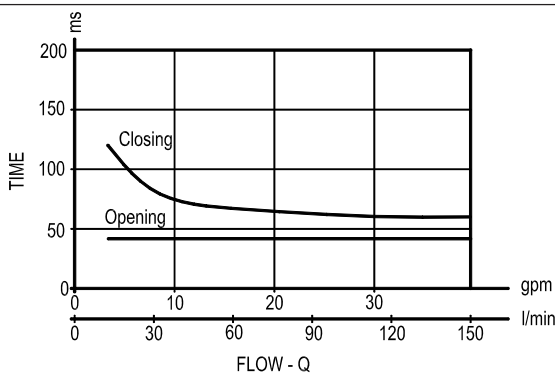
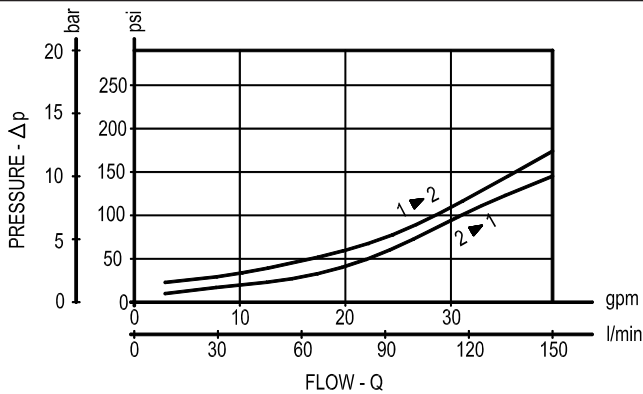

Y ORDERING OPTIONS

1A	Standard	
1B	Push Style Manual Override	
1C	Push and Twist Style Manual Override	

**SOLENOID OPERATED VALVES
 POPPET 2-WAY DOUBLE LOCK NORMALLY OPEN
 COMMON CAVITY**

VEI-8A-2T-06-NA-S-NSS

SIZE 08

OD.15.32.18 - Y - S0

PATENT PENDING

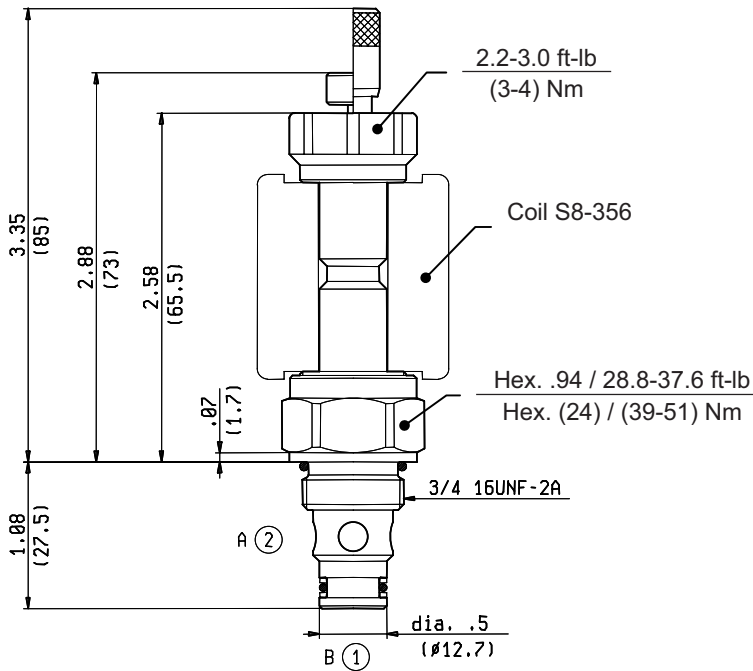

Inches
(mm)

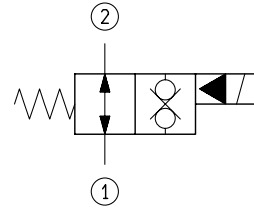

TECHNICAL DATA

Maximum Operating Pressure	5000 psi (350 bar)
Fatigue Cycle Life at 5000 psi (350 bar) and 0.5 Hz (1 s ON - 1 s OFF)	10 million cycles
Rated Flow	11 gpm (40 l/min)
Cavity - Tooling (CA-08A-2N)	page CT.A.001.U
Line bodies	page MN2.A...
Weight	0.286 lbs (0.130 kg)
Fluids - Temperatures	page 7.01.040
Testing Conditions - Seals	page 7.01.040
Internal Leakage	page 7.01.040
Filtration : 25 µm nominal or better	page 7.01.050
Minimum Voltage Required	90% of nominal
Coils must be ordered separately	page 1.71.042
Mounting Position	unrestricted

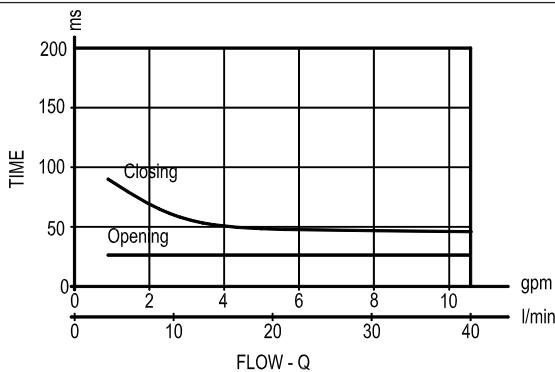
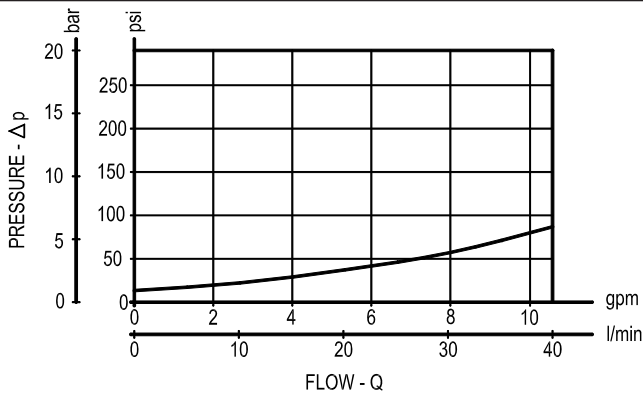

Y ORDERING OPTIONS

1A	Standard	
1B	Push Style Manual Override	
1C	Push and Twist Style Manual Override	

**SOLENOID OPERATED VALVES
POPPET 2-WAY DOUBLE LOCK NORMALLY CLOSED
COMMON CAVITY**



VEI-8A-2T-06-NC-S-NSS SIZE 08 OD.15.31.18 - Y - S0

PATENT PENDING

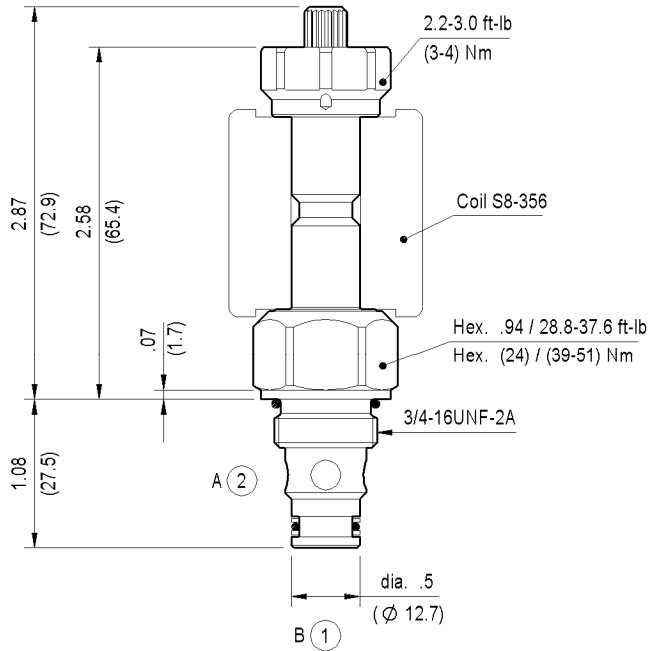

Inches
(mm)

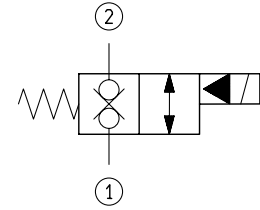

TECHNICAL DATA

Maximum Operating Pressure	5000 psi (350 bar)
Fatigue Cycle Life at 5000 psi (350 bar) and 0.5 Hz (1 s ON - 1 s OFF)	10 million cycles
Rated Flow	11 gpm (40 l/min)
Cavity - Tooling (CA-08A-2N)	page CT.A.001.U
Line bodies	page MN2.A...
Weight	0.286 lbs (0.130 kg)
Fluids - Temperatures	page 7.01.040
Testing Conditions - Seals	page 7.01.040
Internal Leakage	page 7.01.040
Filtration : 25 µm nominal or better	page 7.01.050
Minimum Voltage Required	90% of nominal
Coils must be ordered separately	page 1.71.042
Mounting Position	unrestricted

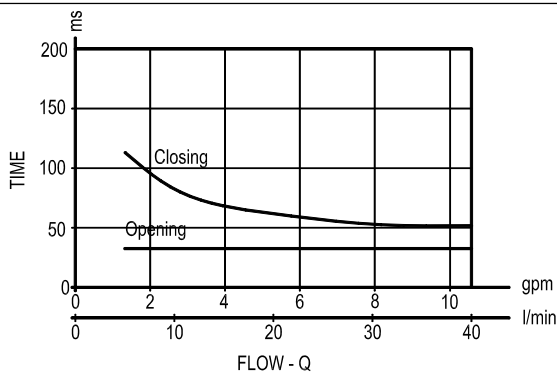
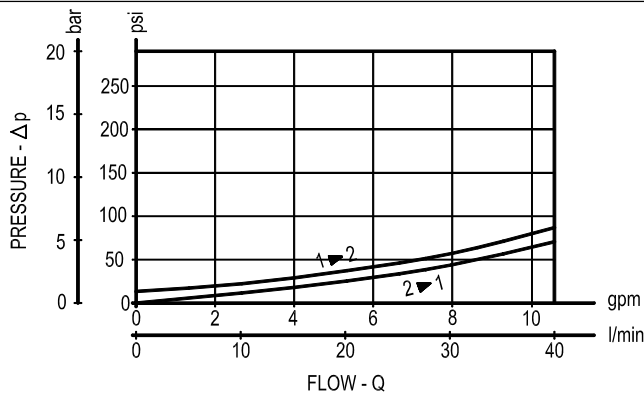

Y ORDERING OPTIONS

3A Standard

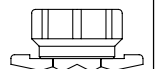

3D Knob Style Manual Override

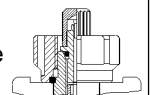

**SOLENOID OPERATED VALVES
POPPET 2-WAY NORMALLY CLOSED
COMMON CAVITY**



VEI-8I-2A-06-NC-S-NSS

SIZE 08

OD.15.05.18 - Y - S0

PATENT PENDING

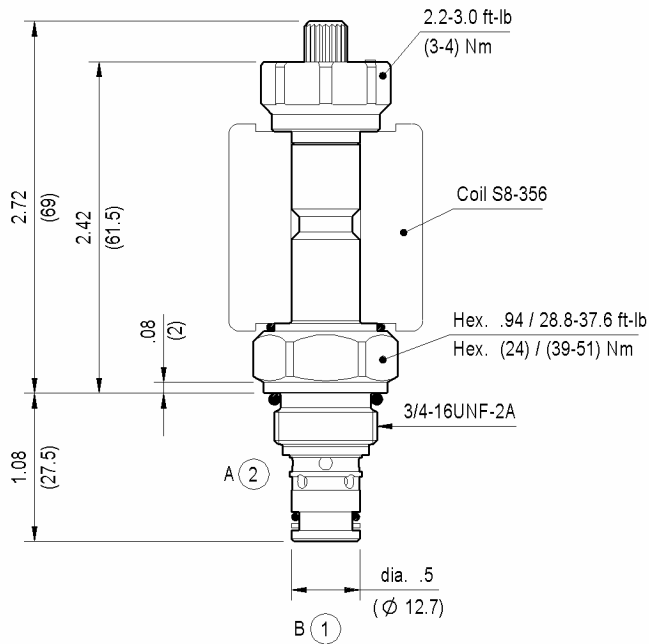

Inches
(mm)

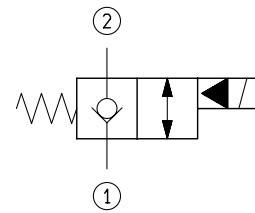

TECHNICAL DATA

Maximum Operating Pressure	5000 psi (350 bar)
Fatigue Cycle Life at 5000 psi (350 bar) and 0.5 Hz (1 s ON - 1 s OFF)	10 million cycles
Rated Flow	8 gpm (30 l/min)
Cavity - Tooling (CA-08A-2N)	page CT.A.001.U
Line bodies	page MN2.A...
Weight	0.286 lbs (0.130 kg)
Fluids - Temperatures	page 7.01.040
Testing Conditions - Seals	page 7.01.040
Internal Leakage	page 7.01.040
Filtration : 25 µm nominal or better	page 7.01.050
Minimum Voltage Required	90% of nominal
Coils must be ordered separately	page 1.71.042
Mounting Position	unrestricted

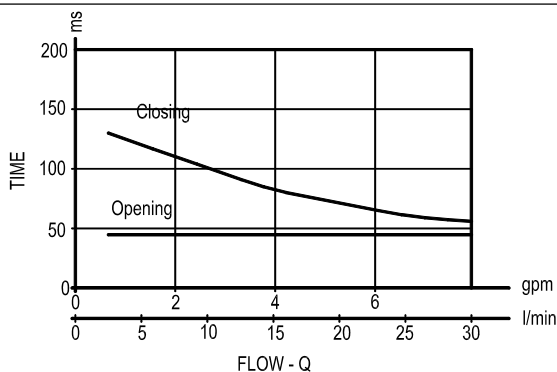
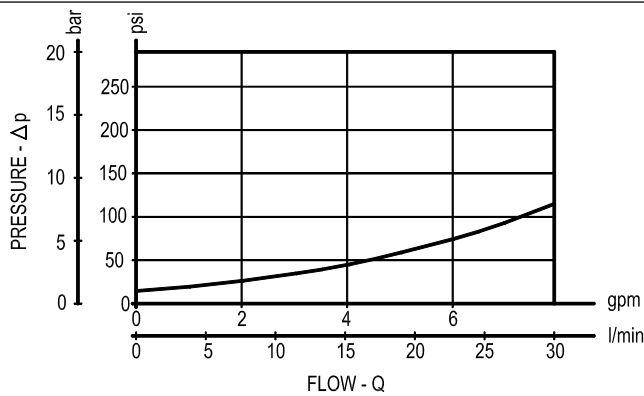

Y ORDERING OPTIONS

3I Standard

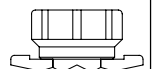

3M Knob Style Manual Override

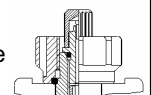

**SOLENOID OPERATED VALVES
POPPET 2-WAY NORMALLY CLOSED
COMMON CAVITY**



VEI-8I-2A-06-NC-S1-NSS SIZE 08 OD.15.01.18 - Y - S0

PATENT PENDING

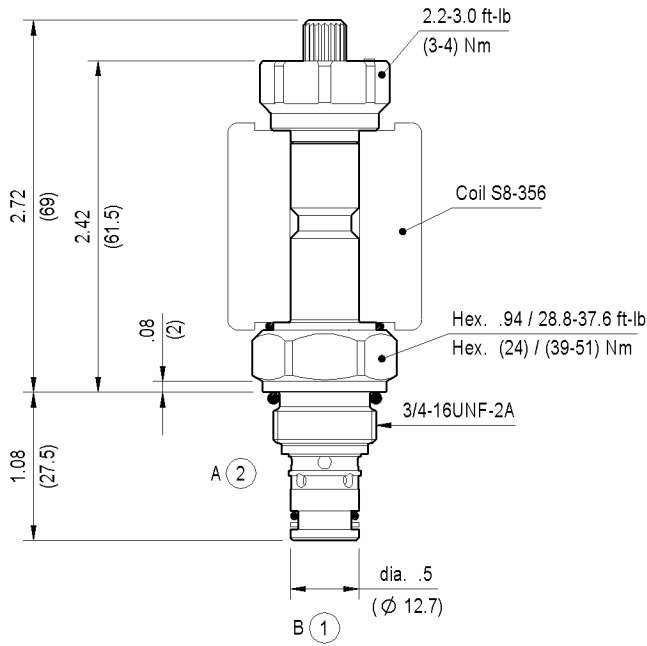

Inches
(mm)

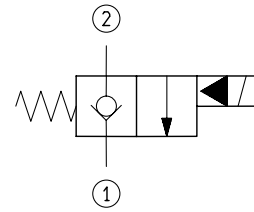

TECHNICAL DATA

Maximum Operating Pressure	5000 psi (350 bar)
Fatigue Cycle Life at 5000 psi (350 bar) and 0.5 Hz (1 s ON - 1 s OFF)	10 million cycles
Rated Flow	8 gpm (30 l/min)
Cavity - Tooling (CA-08A-2N)	page CT.A.001.U
Line bodies	page MN2.A...
Weight	0.286 lbs (0.130 kg)
Fluids - Temperatures	page 7.01.040
Testing Conditions - Seals	page 7.01.040
Internal Leakage	page 7.01.040
Filtration : 25 µm nominal or better	page 7.01.050
Minimum Voltage Required	90% of nominal
Coils must be ordered separately	page 1.71.042
Mounting Position	unrestricted

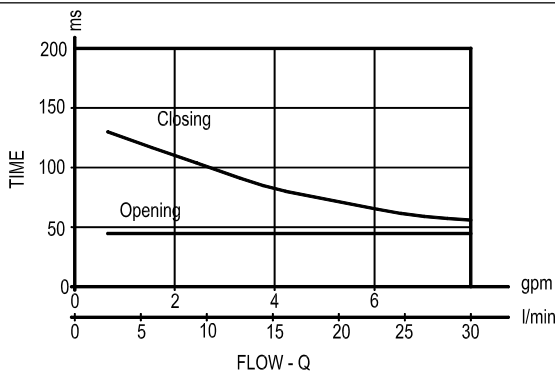
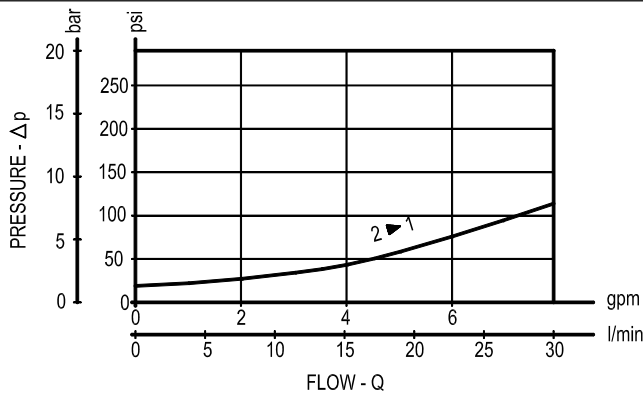

Y ORDERING OPTIONS

3I Standard

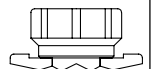

3M Knob Style Manual Override

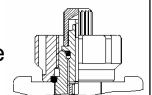

**SOLENOID OPERATED VALVES
CONTINUOUS DUTY COILS - ED 100%**



S8-356 SERIES - CLASS H

OD.02.17 - X - Y - Z

S8-H S8-A S8-G
DIN 43650 - ISO 4400 AMP JUNIOR SINGLE LEAD

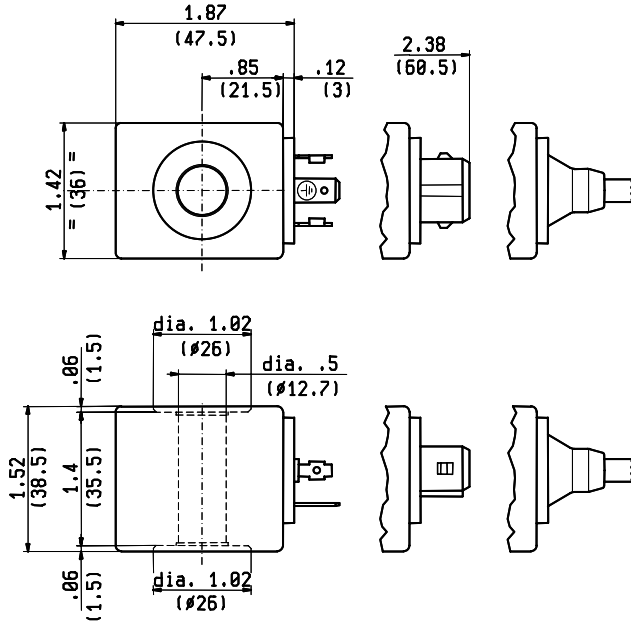

Inches
(mm)

TECHNICAL DATA

General coil information page 7.01.010

Weight 0.397 lbs (0.180 kg)

Encapsulating material IXEF

HEAT INSULATION CLASS H 356 °F (180 °C)

Ambient temperature range -86 +140 °F (-30 +60 °C)

Available on request : Different Voltages - Different connectors mounted on single lead.

Inlet voltage fluctuations must not exceed ± 10% of nominal voltage to obtain correct operation and long life of coils.

X	Y	Connections	Circuit	Voltage
01	30	DIN 43650 - ISO 4400	Standard	DC-RAC
07	30	AMP JUNIOR	Standard	DC only
0G	03	SINGLE LEAD	Standard	DC only
14	30	DIN 43650 - ISO 4400	Bidirectional Diode	DC only
15	30	AMP JUNIOR	Bidirectional Diode	DC only
0H	03	SINGLE LEAD	Bidirectional Diode	DC only

Length
11.8 inches (300 mm)
Ext. diameter
0.25 inches (6.3 mm)
External and Internal Sheath
Silicone rubber

Z	Voltage V	Resistance Ω (±7%)	Power W	Current A		ΔT °F (°C)
	Nominal	Ta = 68-77 °F (20-25 °C)	Cold Coil	Cold Coil	Hot Coil	1 hour energized at Ta = 68-77 °F (20-25 °C) Nominal Voltage
OB	12 DC	7.4	20	1.62	1.19	221-230 (105-110)
OC	24 DC	28.5	20	0.85	0.61	
OV	24 RAC		20			
OW	110 RAC		20			
OZ	220 RAC		20			
OG	14 DC		20			
AC	26 DC	34.3	20	0.76	0.54	

**SOLENOID OPERATED VALVES
 CONTINUOUS DUTY COILS - ED 100%**

S8-356 SERIES - CLASS H

OD.02.17 - X - Y - Z

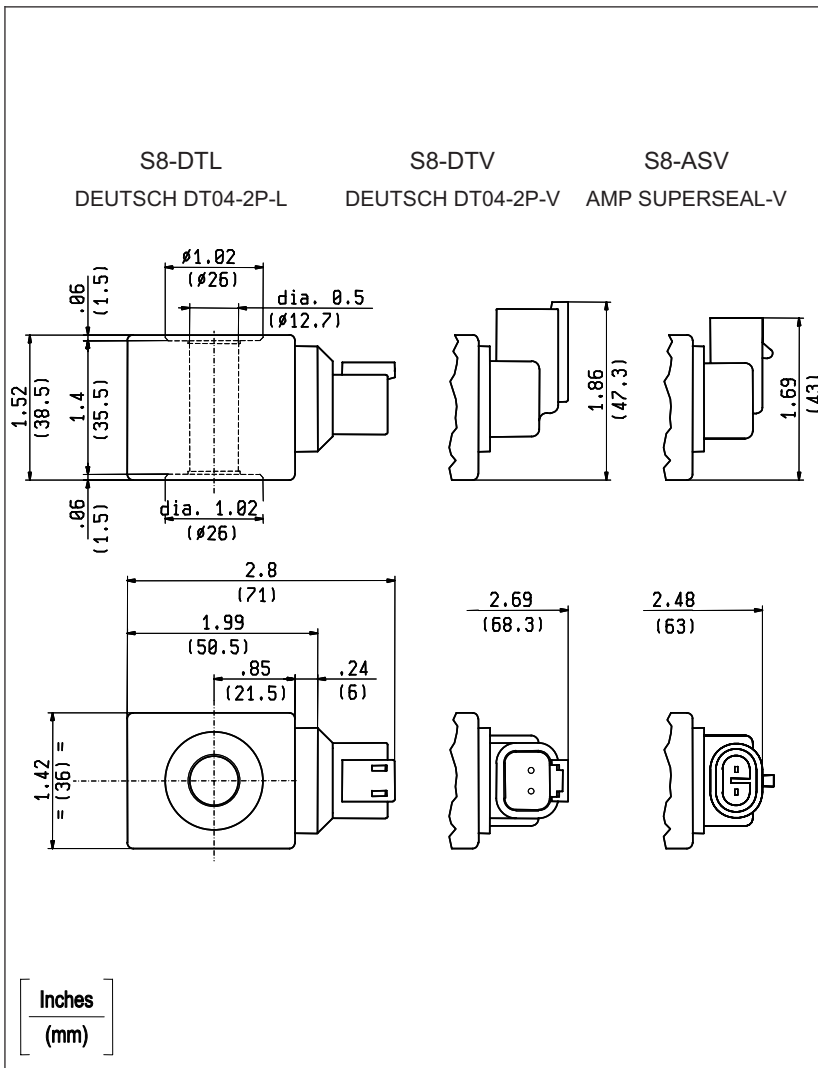

TECHNICAL DATA

General coil information page 7.01.010

Weight 0.397 lbs (0.180 kg)

Encapsulating material IXEF

Protection **IP 69K** DIN 40050 part 9
 These coils have passed the THERMAL SHOCK DUNK TEST, see page 7.01.010

HEAT INSULATION CLASS H 356 °F (180 °C)

Ambient temperature range -86 +140 °F (-30 +60 °C)

Available on request : Different Voltages - Different connectors mounted on single lead.

Inlet voltage fluctuations must not exceed ± 10% of nominal voltage to obtain correct operation and long life of coils.

X	Y	Connections	Circuit	Voltage
20	30	DEUTSCH DT04-2P-L	Standard	DC only
20	3P	DEUTSCH DT04-2P-V	Standard	DC only
30	3P	AMP SUPERSEAL-V	Standard	DC only
22	30	DEUTSCH DT04-2P-L	Bidirectional Diode	DC only
22	3P	DEUTSCH DT04-2P-V	Bidirectional Diode	DC only
32	3P	AMP SUPERSEAL-V	Bidirectional Diode	DC only

Z	Voltage V	Resistance Ω (±7%)	Power W	Current A		ΔT °F (°C)
	Nominal	Ta = 68-77 °F (20-25 °C)	Cold Coil	Cold Coil	Hot Coil	1 hour energized at Ta = 68-77 °F (20-25 °C) Nominal Voltage
OB	12 DC	7.4	20	1.62	1.19	221-230 (105-110)
OC	24 DC	28.5	20	0.85	0.61	
AC	26 DC	34.3	20	0.76	0.54	

STANDARD MANIFOLDS (SECTION 2)
COMMON CAVITY



2 WAY ALUMINIUM **SIZE 08**

Inches
(mm)

CAVITY	CA-08A-2N
Dimensions on page	CT.A.001.U

ORDERING CODE	PORTS	WEIGHT
	A-B	Lbs (Kg)
OC.10.09.009	G 1/4	0.331 (0.150)
OC.10.09.004	G 3/8	0.331 (0.150)

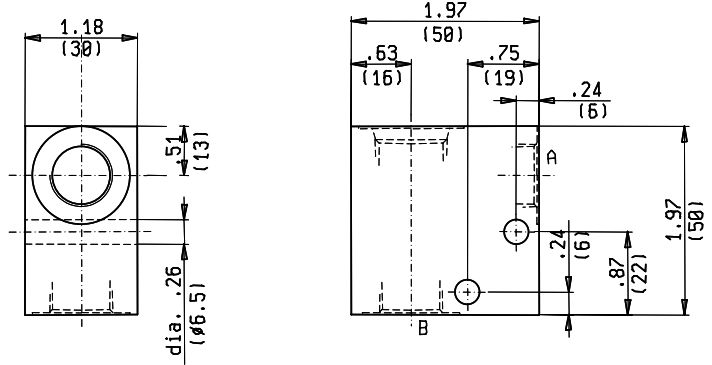

MAX. PRESSURE	3600 psi (250 bar)	FEATURES
		Standard manifolds in high-strength aluminum for working pressures up to 3600 psi (250 bar).

**MANIFOLDS (SECTION 2)
 COMMON CAVITY**

2 WAY STEEL

SIZE 08

Inches
 (mm)

CAVITY	CA-08A-2N
Dimensions on page	CT.A.001.U

ORDERING CODE	PORTS	WEIGHT
	A-B	Lbs (Kg)
OC.10.09.067	G 1/4	0.992 (0.450)
OC.10.09.066	G 3/8	0.992 (0.450)

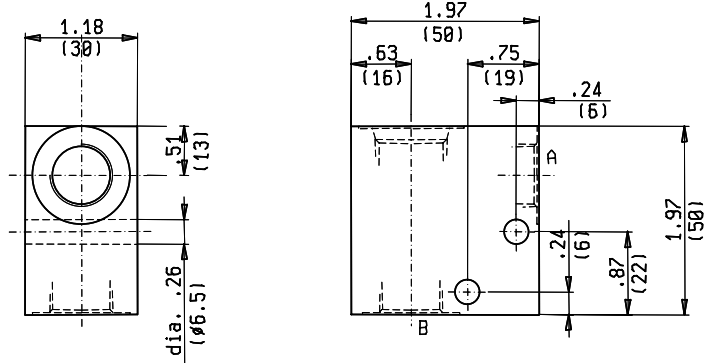

MAX. PRESSURE	6500 psi (450 bar)	FEATURES
		These manifolds can be supplied upon request for working pressures up to 6500 psi (450 bar) and for fatigue cycle applications.

STANDARD MANIFOLDS (SECTION 2)
COMMON CAVITY



3 WAY 4 WAY ALUMINIUM **SIZE 08**

Inches
(mm)

CAVITY	CA-08A-3N
Dimensions on page	CT.A.003.U

ORDERING CODE	PORTS	WEIGHT
	P-C-C1/T	Lbs (Kg)
OC.10.09.042	G 1/4	0.331 (0.150)
OC.10.09.048	G 3/8	0.331 (0.150)

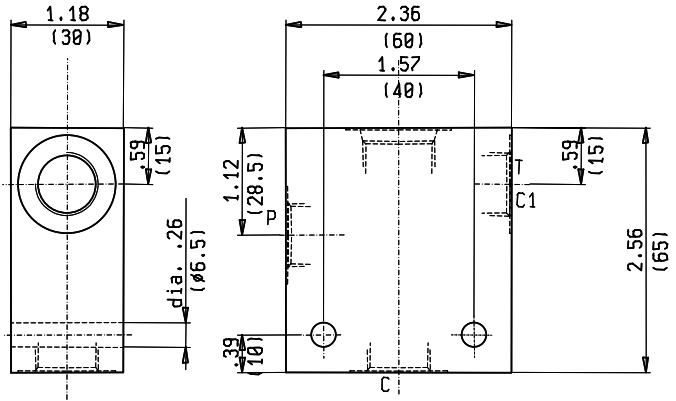

CAVITY	CA-08A-4N
Dimensions on page	CT.A.004.U

ORDERING CODE	PORTS	WEIGHT
	A-B-P-T	Lbs (Kg)
OC.10.09.047	G 1/4	0.331 (0.150)
OC.10.09.046	G 3/8	0.331 (0.150)

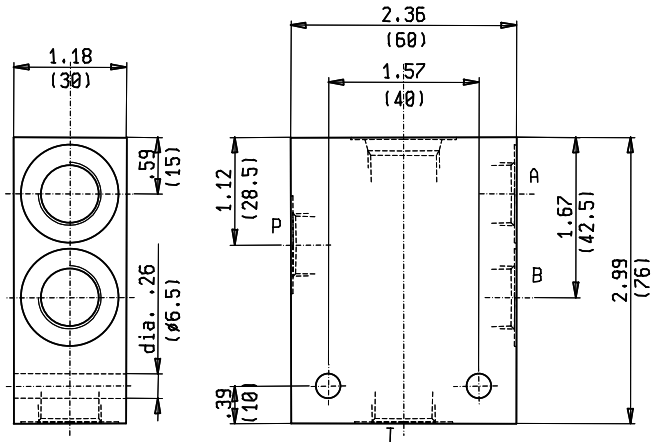

MAX. PRESSURE	3600 psi (250 bar)	FEATURES Standard manifolds in high-strength aluminum for working pressures up to 3600 psi (250 bar).
----------------------	-------------------------------	---

**STANDARD MANIFOLDS (SECTION 2)
 COMMON CAVITY**

3 WAY 4 WAY ALUMINIUM SIZE 10

CAVITY	CA-10A-3N
Dimensions on page	CT.A.003.U

ORDERING CODE	PORTS	WEIGHT
	P-C-C1/T	Lbs (Kg)
OC.10.09.116	G 1/4	0.375 (0.170)
OC.10.09.115	G 3/8	0.375 (0.170)

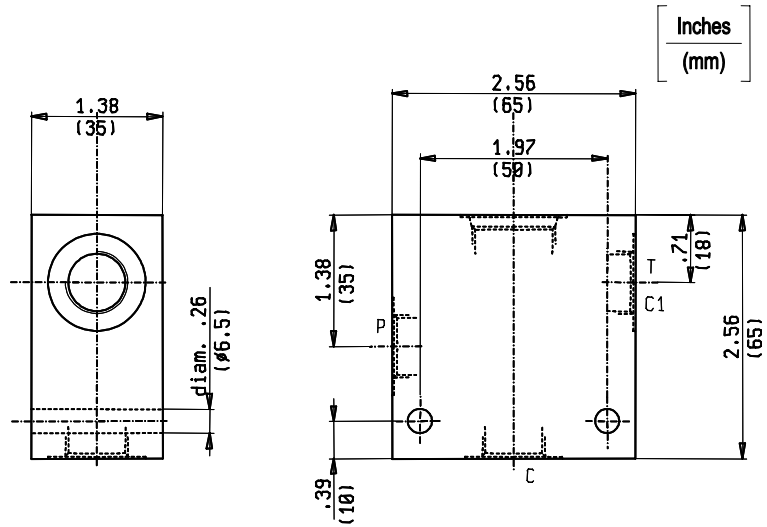

CAVITY	CA-10A-4N
Dimensions on page	CT.A.004.U

ORDERING CODE	PORTS	WEIGHT
	A-B-P-T	Lbs (Kg)
OC.10.09.117	G 1/4	0.375 (0.170)
OC.10.09.118	G 3/8	0.375 (0.170)

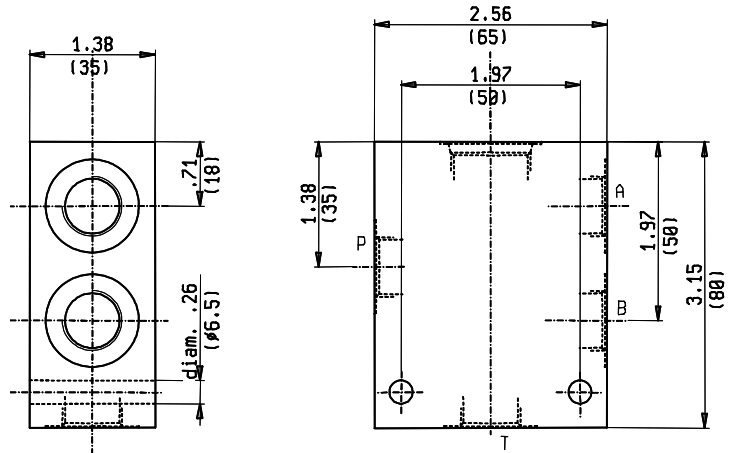

MAX. PRESSURE	3600 psi (250 bar)	FEATURES
		Standard manifolds in high-strength aluminum for working pressures up to 3600 psi (250 bar).

MANIFOLDS (SECTION 2)
SPECIAL CAVITY

2 WAY ALUMINIUM

Inches
(mm)

CAVITY	017-E
Dimensions on page	CT.S.005.U

ORDERING CODE	PORTS	WEIGHT
	A-B	Lbs (Kg)
OC.10.09.015	G 1/2	0.441 (0.200)
OC.10.09.012	G 3/4	0.441 (0.200)

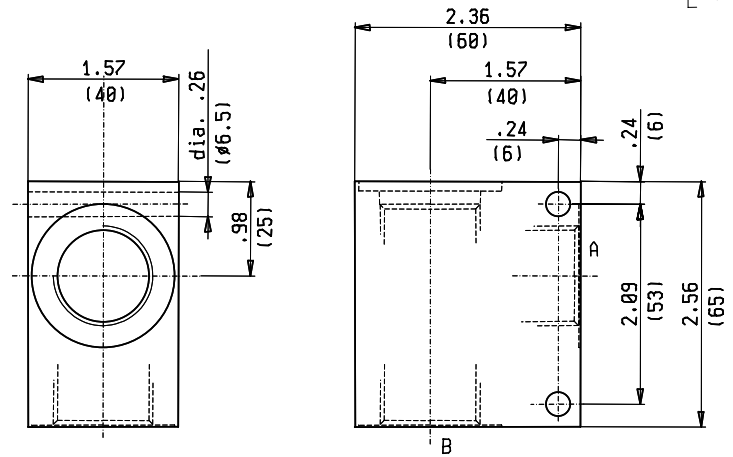

CAVITY	021-E
Dimensions on page	CT.S.005.U

ORDERING CODE	PORTS	WEIGHT
	A-B	Lbs (Kg)
OC.10.09.017	G 3/4	1.367 (0.620)
OC.10.09.019	G 1	1.367 (0.620)

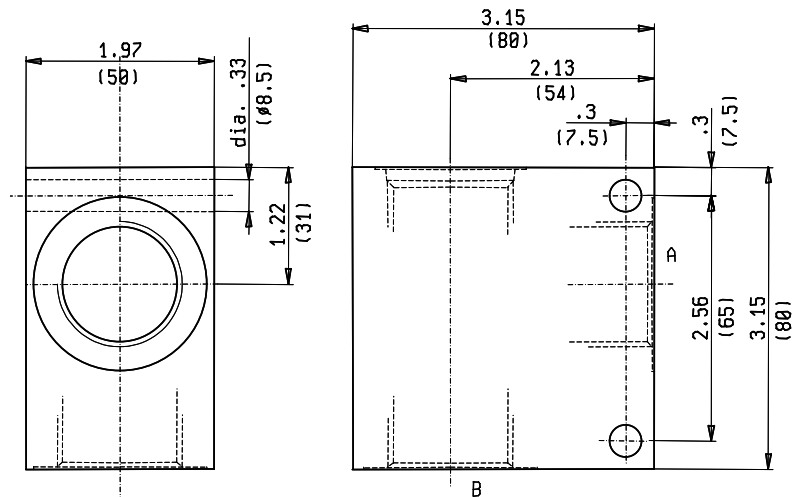

MAX. PRESSURE	3600 psi (250 bar)	FEATURES
		Standard manifolds in high-strength aluminum for working pressures up to 3600 psi (250 bar).

MANIFOLDS (SECTION 2)
SPECIAL CAVITY



2 WAY ALUMINIUM

Inches
(mm)

CAVITY	019-E
Dimensions on page	CT.S.005.U

ORDERING CODE	PORTS	WEIGHT
	A-B	Lbs (Kg)
OC.10.09.103	G 1/4	0.331 (0.150)
OC.10.09.054	G 3/8	0.331 (0.150)

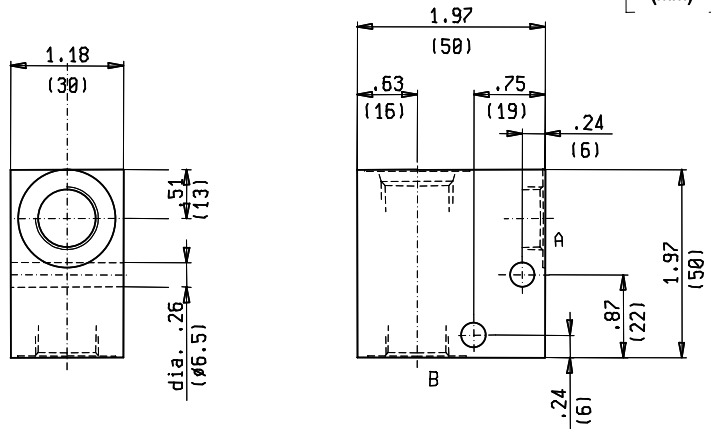

CAVITY	004
Dimensions on page	CT.S.001.U

ORDERING CODE	PORTS	WEIGHT
	A-B	Lbs (Kg)
OC.10.09.040	G 1	2.646 (1.200)
OC.10.09.041	G 1-1/4	2.646 (1.200)

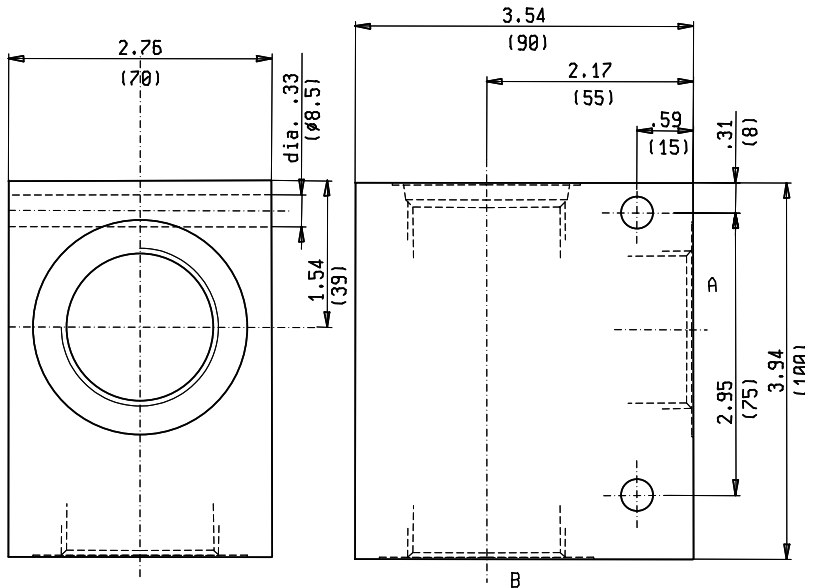

CAVITY	081-E
Dimensions on page	CT.S.005.U

ORDERING CODE	PORTS	WEIGHT
	A-P-T	Lbs (Kg)
OC.10.09.128	G 1/4	0.397 (0.180)

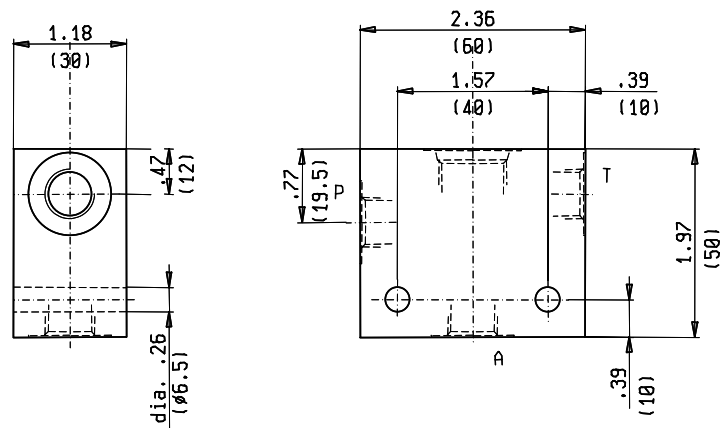

MAX. PRESSURE	3600 psi (250 bar)	FEATURES
		Standard manifolds in high-strength aluminum for working pressures up to 3600 psi (250 bar).

**MANIFOLDS (SECTION 2)
 SPECIAL CAVITY**

2 WAY STEEL

Inches
 (mm)

CAVITY	017-E
Dimensions on page	CT.S.005.U

ORDERING CODE	PORTS	WEIGHT
	A-B	Lbs (Kg)
OC.10.09.074	G 1/2	1.984 (0.900)
OC.10.09.073	G 3/4	1.984 (0.900)

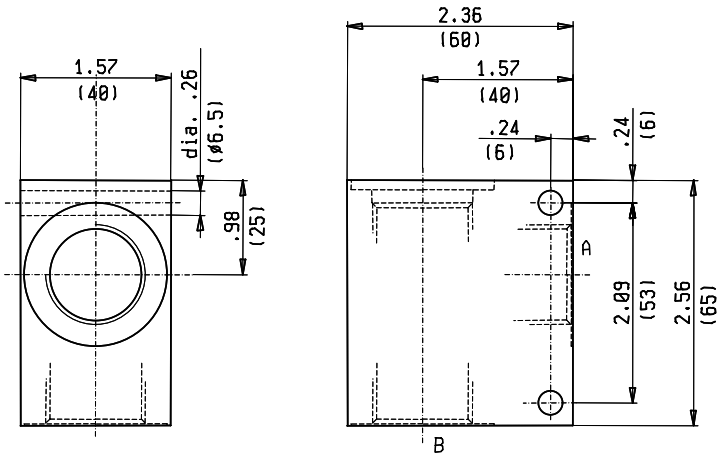

CAVITY	021-E
Dimensions on page	CT.S.005.U

ORDERING CODE	PORTS	WEIGHT
	A-B	Lbs (Kg)
OC.10.09.075	G 3/4	2.866 (1.300)
OC.10.09.076	G 1	2.866 (1.300)

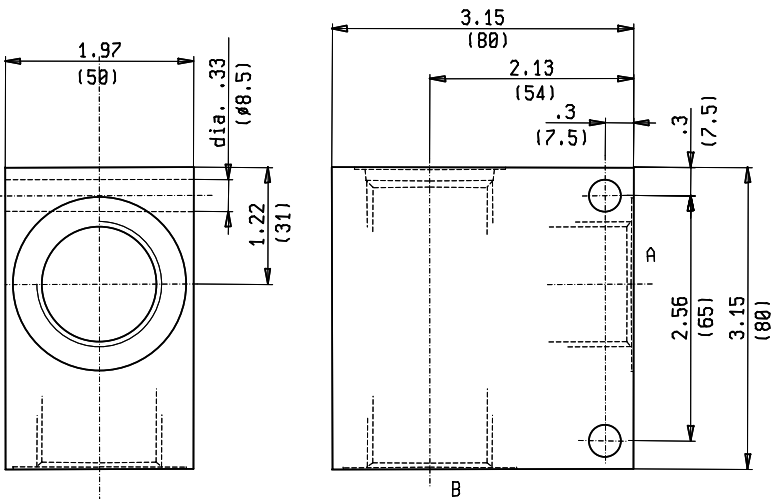

MAX. PRESSURE	6500 psi (450 bar)	FEATURES
		These manifolds can be supplied upon request for working pressures up to 6500 psi (450 bar) and for fatigue cycle applications.

2 WAY STEEL

Inches
(mm)

CAVITY	019-E
Dimensions on page	CT.S.005.U

ORDERING CODE	PORTS	WEIGHT Lbs (Kg)
	A-B	
OC.10.09.102	G 1/4	0.992 (0.450)
OC.10.09.101	G 3/8	0.992 (0.450)

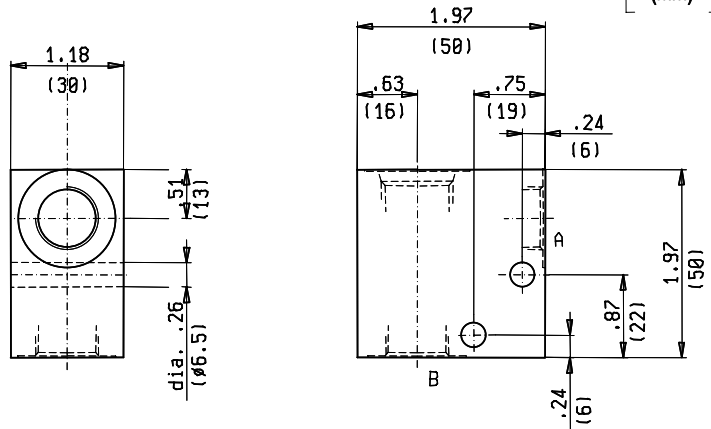

CAVITY	004
Dimensions on page	CT.S.001.U

ORDERING CODE	PORTS	WEIGHT Lbs (Kg)
	A-B	
OC.10.09.122	G 1	7.716 (3.500)
OC.10.09.056	G 1-1/4	7.716 (3.500)

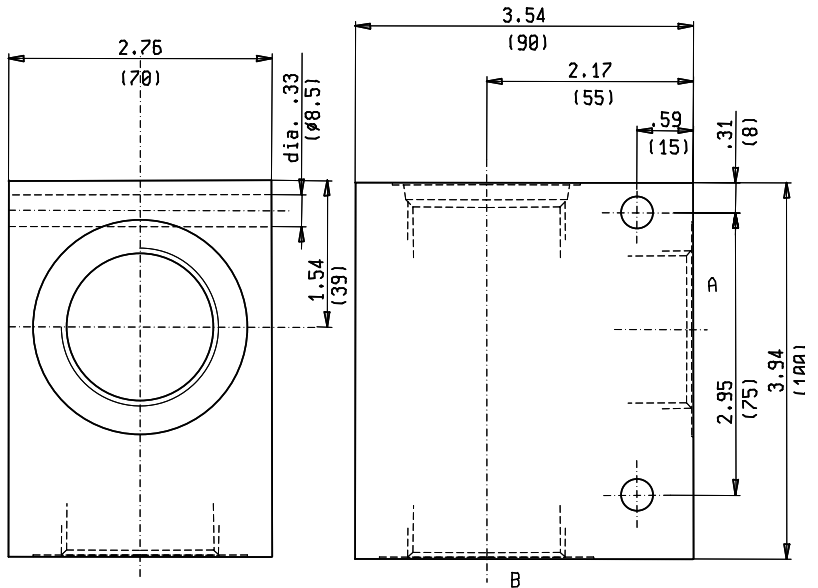

CAVITY	081-E
Dimensions on page	CT.S.005.U

ORDERING CODE	PORTS	WEIGHT Lbs (Kg)
	A-P-T	
OC.10.09.162	G 1/4	1.191 (0.540)

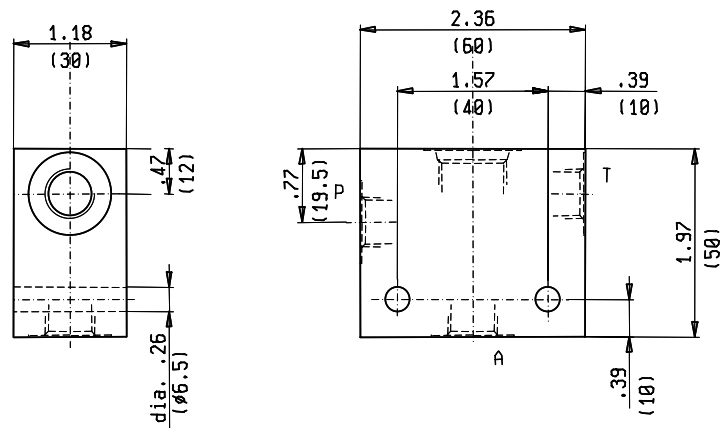

MAX. PRESSURE	6500 psi (450 bar)	FEATURES
		These manifolds can be supplied upon request for working pressures up to 6500 psi (450 bar) and for fatigue cycle applications.

**STANDARD MANIFOLDS (SECTION 1)
 COMMON CAVITY**

CA-xxx-2N

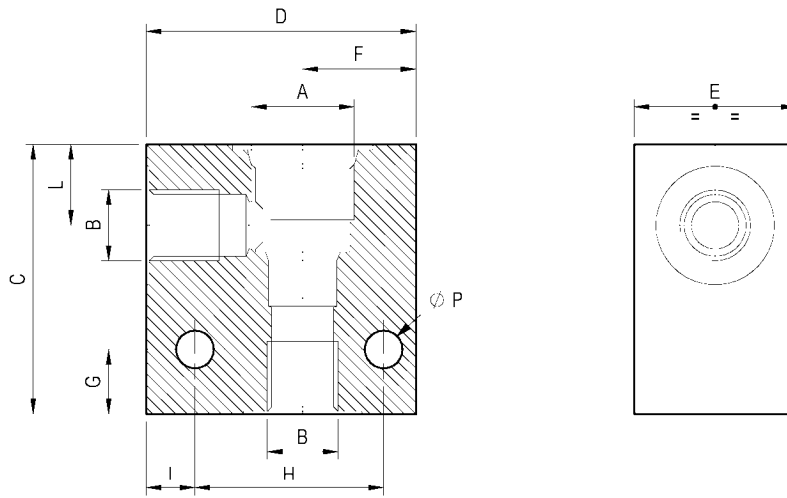

CAVITY	DIMENSIONS (mm)												ORDERING CODES		
	A	B	C	D	E	F	G	H	I	L	M	N	P	Aluminium	Steel
CA-08A-2N	G 1/4	50	50	30	21	12	35	9	15				7	03.30.05.168	03.30.05.169
	G 3/8	50	50	30	21	12	35	9	15				7	03.30.05.170	03.30.05.171
	7/16-20	50	50	30	21	12	35	9	15				7	03.30.05.172	03.30.05.173
	9/16-18	50	50	30	21	12	35	9	15				7	03.30.05.174	03.30.05.175
CA-10A-2N	G 3/8	60	60	35	25	15	45	7	19				7	03.30.05.176	03.30.05.177
	G 1/2	60	60	35	25	15	45	7	19				7	03.30.05.178	03.30.05.179
	G 3/4	60	70	40	30	15	55	9	20				9		03.30.05.226
	9/16-18	60	60	35	25	15	45	7	19				7	03.30.05.180	03.30.05.181
	3/4-16	60	60	35	25	15	45	7	19				7	03.30.05.182	03.30.05.183
	7/8-14	60	60	35	25	15	45	7.5	19				7	03.30.05.247	03.30.05.248
CA-12A-2N	G 1/2	75	80	40	35	20	60	10	26.5				9	03.30.05.228	03.30.05.229
	G 3/4	75	80	40	35	20	60	10	26.5				9	03.30.05.289	03.30.05.290
CA-16A-2N	G 3/4	80	80	50	32	22	60	10	26				9	03.30.05.166	03.30.05.184
	G 1	80	90	50	37	22	60	20	26				9	03.30.05.216	03.30.05.215
	1-1/16-12	80	80	50	32	22	60	10	26				9	03.30.05.185	03.30.05.186
CA-20A-2N															

Available on request Ports ISO 6149 and JIS B 2351-90 type 0

STANDARD MANIFOLDS (SECTION 1)
COMMON CAVITY

CA-xxx-3C

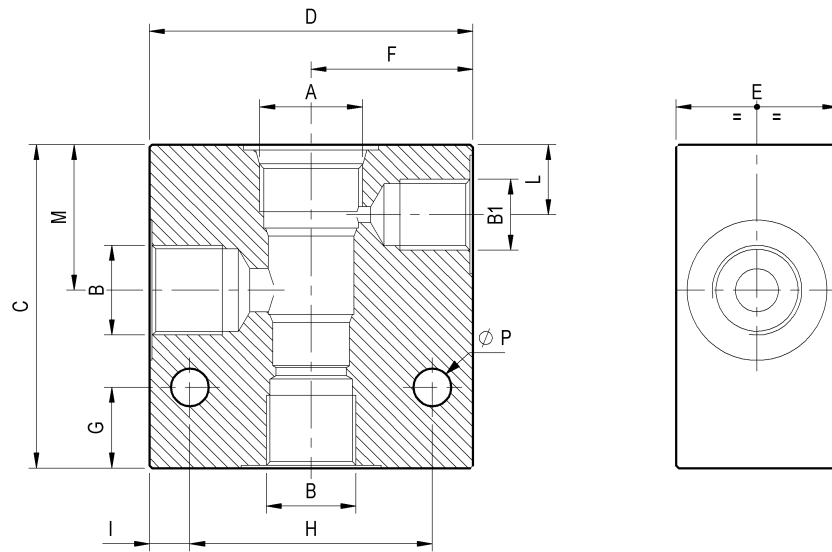

CAVITY	DIMENSIONS (mm)												ORDERING CODES	
	A	B	B1	C	D	E	F	G	H	I	L	M	P	Aluminium
CA-08A-3C	G 3/8	G 1/4	60	60	30	30	15	45	7.5	13	27	7	03.30.05.187	03.30.05.188
	9/16-18	7/16-20	60	60	30	30	15	45	7.5	13	27	7	03.30.05.189	03.30.05.190
CA-10A-3C	G 3/8	G 1/4	70	60	35	30	15	45	7.5	15	32	7	03.30.05.192	
	G 1/2	G 1/4	70	70	35	32	15	55	7.5	15	32	7	03.30.05.193	03.30.05.194
	9/16-18	7/16-20	70	70	35	32	15	55	7.5	15	32	7	03.30.05.195	03.30.05.196
	7/8-14	9/16-18	70	70	35	32	15	55	7.5	15	32	7	03.30.05.243	03.30.05.244
CA-12A-3C	G 1/2	G 1/4	80	75	40	35	15	55	10	24	42	7	03.30.05.217	03.30.05.218
	7/8-14	9/16-18	80	75	40	35	15	55	10	24	42	7	03.30.05.245	03.30.05.246
CA-16A-3C	G 1	G 1/4	90	90	50	40	22	70	10	18.5	39	9	03.30.05.167	03.30.05.197
	1-5/16-12	7/16-20	90	90	50	40	22	70	10	18.5	39	9	03.30.05.198	03.30.05.199
CA-20A-3C	G 1-1/4	G 1/4	110	100	60	45	25	75	12.5	21	51	11	03.30.05.200	03.30.05.201
	1-5/8-12	7/16-20	110	100	60	45	25	75	12.5	21	51	11	03.30.05.202	03.30.05.203

Available on request Ports ISO 6149 and JIS B 2351-90 type 0

**STANDARD MANIFOLDS (SECTION 1)
 COMMON CAVITY**

CA-xxx-3N

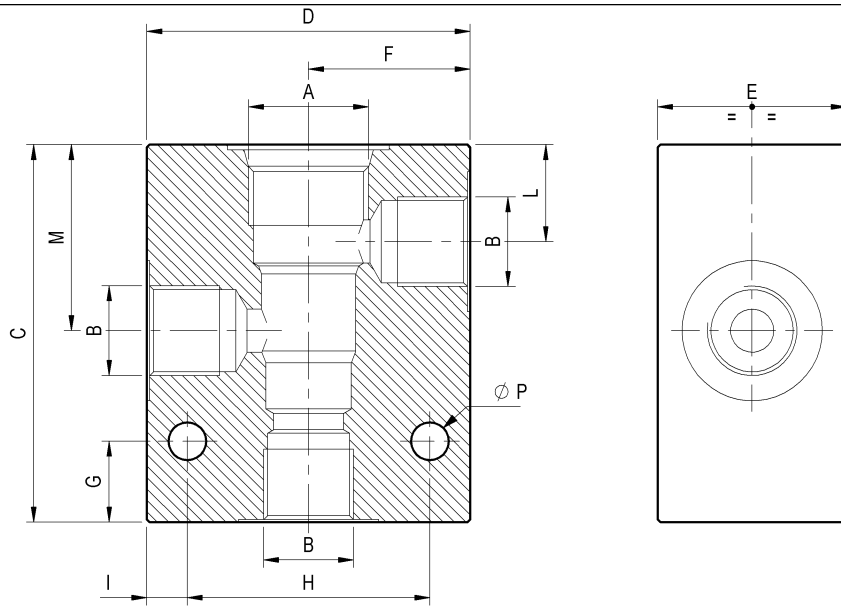

CAVITY	DIMENSIONS (mm)												ORDERING CODES		
	A	B	C	D	E	F	G	H	I	L	M	N	P	Aluminium	Steel
CA-08A-3N															
CA-10A-3N	G 3/8	70	60	35	30	15	45	7.5	18	34.5		7	03.30.05.204	03.30.05.205	
	9/16-18	70	60	35	30	15	45	7.5	18	34.5		7	03.30.05.206	03.30.05.207	
CA-12A-3N															
CA-16A-3N	G 3/4	100	90	50	45	20	60	15	26	54.5		10.5	03.30.05.232	03.30.05.233	
CA-20A-3N															

Available on request Ports ISO 6149 and JIS B 2351-90 type 0

STANDARD MANIFOLDS (SECTION 1)
COMMON CAVITY

CA-xxx-4N

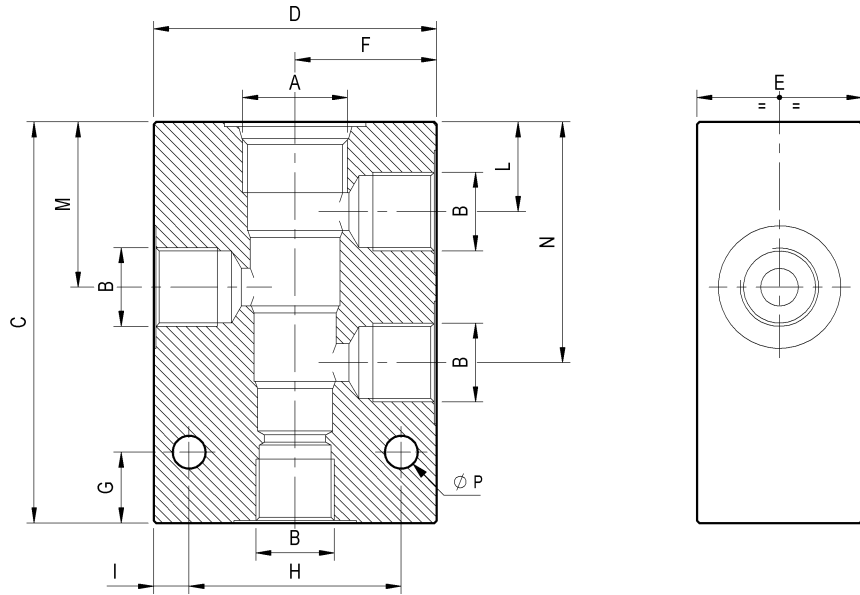

CAVITY	DIMENSIONS (mm)												ORDERING CODES		
	A	B	C	D	E	F	G	H	I	L	M	N	P	Aluminium	Steel
CA-08A-4N															
CA-10A-4N	G 3/8	85	60	35	30	15	45	7.5	19	35	51	7	03.30.05.211	03.30.05.209	
	9/16-18	85	60	35	30	15	45	7.5	19	35	51	7	03.30.05.249	03.30.05.250	
CA-12A-4N															
CA-16A-4N	G 3/4	130	90	50	45	20	60	15	26	54.5	83	10.5	03.30.05.230	03.30.05.231	
	1-1/16-12	125	90	50	45	15	60	15	26	54.5	83	9	03.30.05.251	03.30.05.252	
CA-20A-4N															

Available on request Ports ISO 6149 and JIS B 2351-90 type 0

**STANDARD MANIFOLDS (SECTION 1)
 COMMON CAVITY**

CA-xxx-4N

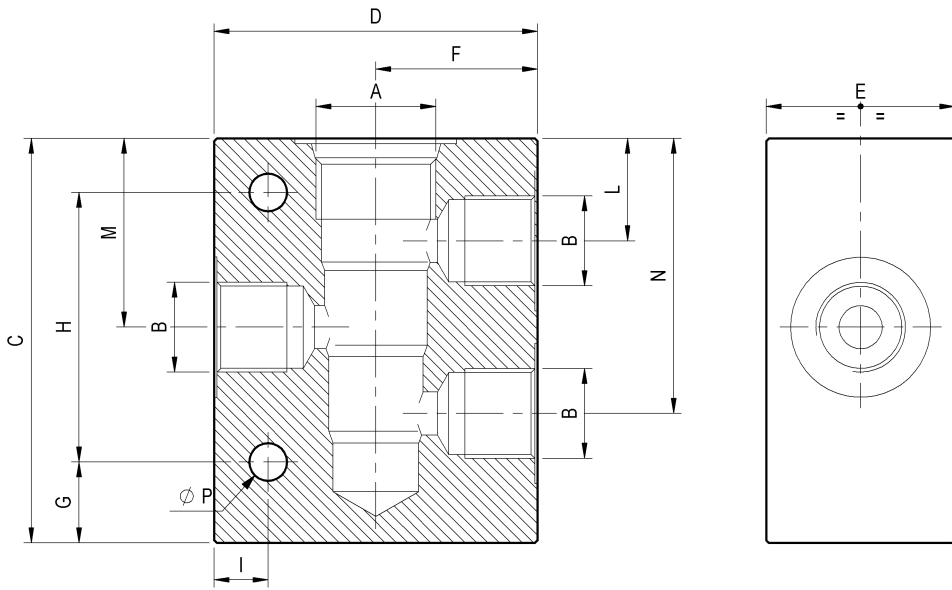

CAVITY	DIMENSIONS (mm)												ORDERING CODES		
	A	B	C	D	E	F	G	H	I	L	M	N	P	Aluminium	Steel
CA-08A-4N															
CA-10A-4N	G 3/8		75	60	35	30	15	50	10	19	35	51	7		03.30.05.210
CA-12A-4N															
CA-16A-4N	1-1/16-12		115	90	50	45	15	80	15	26	54.5	83	9	03.30.05.253	03.30.05.254
CA-20A-4N															

Available on request Ports ISO 6149 and JIS B 2351-90 type 0

STANDARD CAVITIES - TOOLS

TWO WAY		CA-08A-2N	CA-10A-2N	CA-12A-2N	CA-16A-2N	CA-20A-2N	
<p>General tolerance : 0.012 (0.3 mm)</p> <p> ⊙ 0.002 (0.03) ⊥ 0.008 (0.02) </p>		A	3/4-16 UNF-2B	7/8-14 UNF-2B	1-1/16 12 UN-2B	1-5/16 12 UN-2B	1-5/8 12 UN-2B
		B	1.024 (26)	1.118 (30)	1.118 (35)	1.118 (42)	1.118 (48)
		C	0.811 ^{+0.004} ₋₀ (20.6 ^{+0.1} ₋₀)	0.941 ^{+0.004} ₋₀ (23.9 ^{+0.1} ₋₀)	1.150 ^{+0.004} ₋₀ (29.2 ^{+0.1} ₋₀)	1.398 ^{+0.004} ₋₀ (35.5 ^{+0.1} ₋₀)	1.713 ^{+0.004} ₋₀ (43.5 ^{+0.1} ₋₀)
		D1	0.500 ^{+0.002} ₋₀ (12.7 ^{+0.05} ₋₀)	0.625 ^{+0.002} ₋₀ (15.87 ^{+0.05} ₋₀)	0.875 ^{+0.002} ₋₀ (22.22 ^{+0.05} ₋₀)	1.126 ^{+0.002} ₋₀ (28.60 ^{+0.05} ₋₀)	1.438 ^{+0.002} ₋₀ (36.52 ^{+0.05} ₋₀)
		E	0.102 ^{+0.012} ₋₀ (2.6 ^{+0.3} ₋₀)	0.102 ^{+0.012} ₋₀ (2.6 ^{+0.3} ₋₀)	0.130 ^{+0.012} ₋₀ (3.3 ^{+0.3} ₋₀)	0.130 ^{+0.012} ₋₀ (3.3 ^{+0.3} ₋₀)	0.134 ^{+0.012} ₋₀ (3.4 ^{+0.3} ₋₀)
		F	0.512 (13)	0.591 (15)	0.787 (20)	0.787 (20)	0.866 (22)
		G	0.354 (9)	0.472 (12)	0.709 (18)	0.748 (19)	0.984 (25)
		G1	0.472 (12)	0.591 (15)	0.748 (19)	0.945 (24)	1.181 (30)
		H1	0.551 (14)	0.709 (18)	1.024 (26)	0.984 (25)	1.260 (32)
		L1	0.807 (20.5)	1.004 (25.5)	1.437 (36.5)	1.417 (36)	1.752 (44.5)
		L2	1.142 (29)	1.358 (34.5)	1.890 (48)	1.929 (49)	2.323 (59)
		M	0.059 (1.5)	0.059 (1.5)	-	-	-

TOOLS (ALUMINIUM/STEEL *)	ORDERING CODE				
DRILL 	∅ G1	∅ G1	∅ G1	∅ G1	∅ G1
FORM DRILL 	P-CA-08A-2N	P-CA-10A-2N	P-CA-12A-2N	P-CA-16A-2N	P-CA-20A-2N
FORM REAMER 	A-CA-08A-2N	A-CA-10A-2N	A-CA-12A-2N	A-CA-16A-2N	A-CA-20A-2N
PLUG TAP 	M-CA-08A	M-CA-10A	M-CA-12A	M-CA-16A	M-CA-20A

* NOTE: Special heavy duty tools are available upon request, for steel drilling.

inches (mm)

STANDARD CAVITIES - TOOLS

THREE WAY	CA-08A-3N	CA-10A-3N	CA-12A-3N	CA-16A-3N	CA-20A-3N	
<p>General tolerance : 0.012 (0.3 mm)</p> <p> ⊙ 0.002 (0.03) ⊥ 0.008 (0.02) </p>	A	3/4-16 UNF-2B	7/8-14 UNF-2B	1-1/16 12 UN-2B	1-5/16 12 UN-2B	1-5/8 12 UN-2B
	B	1.024 (26)	1.118 (30)	1.118 (35)	1.118 (42)	2.126 (54)
	C	0.811 ^{+0.004} ₋₀ (20.6 ^{+0.1} ₋₀)	0.941 ^{+0.004} ₋₀ (23.9 ^{+0.1} ₋₀)	1.150 ^{+0.004} ₋₀ (29.2 ^{+0.1} ₋₀)	1.398 ^{+0.004} ₋₀ (35.5 ^{+0.1} ₋₀)	1.713 ^{+0.004} ₋₀ (43.5 ^{+0.1} ₋₀)
	D1	0.625 ^{+0.002} ₋₀ (15.87 ^{+0.05} ₋₀)	0.688 ^{+0.002} ₋₀ (17.47 ^{+0.05} ₋₀)	0.937 ^{+0.002} ₋₀ (23.80 ^{+0.05} ₋₀)	1.126 ^{+0.002} ₋₀ (28.60 ^{+0.05} ₋₀)	1.438 ^{+0.002} ₋₀ (36.52 ^{+0.05} ₋₀)
	D2	0.562 ^{+0.002} ₋₀ (14.27 ^{+0.05} ₋₀)	0.625 ^{+0.002} ₋₀ (15.87 ^{+0.05} ₋₀)	0.875 ^{+0.002} ₋₀ (22.22 ^{+0.05} ₋₀)	1.063 ^{+0.002} ₋₀ (27.00 ^{+0.05} ₋₀)	1.313 ^{+0.002} ₋₀ (33.35 ^{+0.05} ₋₀)
	E	0.102 ^{+0.012} ₋₀ (2.6 ^{+0.3} ₋₀)	0.102 ^{+0.012} ₋₀ (2.6 ^{+0.3} ₋₀)	0.130 ^{+0.012} ₋₀ (3.3 ^{+0.3} ₋₀)	0.130 ^{+0.012} ₋₀ (3.3 ^{+0.3} ₋₀)	0.134 ^{+0.012} ₋₀ (3.4 ^{+0.3} ₋₀)
	F	0.512 (13)	0.551 (14)	0.787 (20)	0.787 (20)	0.866 (22)
	G	0.236 (6)	0.315 (8)	0.551 (14)	0.669 (17)	0.984 (25)
	G1	0.472 (12)	0.591 (15)	0.748 (19)	0.945 (24)	1.181 (30)
	H1	0.591 (15)	0.709 (18)	1.102 (28)	1.004 (25.5)	1.260 (32)
	H2	1.142 (29)	1.339 (34)	2.087 (53)	2.126 (54)	2.835 (72)
	L1	0.768 (19.5)	0.925 (23.5)	1.437 (36.5)	1.398 (35.5)	1.811 (46)
	L2	1.319 (33.5)	1.555 (39.5)	2.421 (61.5)	2.520 (64)	3.386 (86)
	L3	1.693 (43)	1.910 (48.5)	2.874 (73)	2.953 (75)	3.937 (100)
	M	-	0.059 (1.5)	-	-	-
M1	-	-	-	-	-	

TOOLS (ALUMINIUM/STEEL *)	ORDERING CODE				
DRILL 	∅ G1	∅ G1	∅ G1	∅ G1	∅ G1
FORM DRILL 	P-CA-08A-3N	P-CA-10A-3N	P-CA-12A-3N	P-CA-16A-3N	P-CA-20A-3N
FORM REAMER 	A-CA-08A-3N	A-CA-10A-3N	A-CA-12A-3N	A-CA-16A-3N	A-CA-20A-3N
PLUG TAP 	M-CA-08A	M-CA-10A	M-CA-12A	M-CA-16A	M-CA-20A

* NOTE: Special heavy duty tools are available upon request, for steel drilling.

inches (mm)

STANDARD CAVITIES - TOOLS

THREE WAY SHORT	CA-08A-3C	CA-10A-3C	CA-12A-3C	CA-16A-3C	CA-20A-3C	
<p>General tolerance : 0.012 (0.3 mm)</p> <p> \varnothing 0.002 (0.03) \perp 0.008 (0.02) </p>	A	3/4-16 UNF-2B	7/8-14 UNF-2B	1-1/16 12 UN-2B	1-5/16 12 UN-2B	1-5/8 12 UN-2B
	B	1.024 (26)	1.118 (30)	1.118 (35)	1.118 (42)	1.118 (48)
	C	0.811 ^{+0.004} ₋₀ (20.6 ^{+0.1} ₋₀)	0.941 ^{+0.004} ₋₀ (23.9 ^{+0.1} ₋₀)	1.150 ^{+0.004} ₋₀ (29.2 ^{+0.1} ₋₀)	1.398 ^{+0.004} ₋₀ (35.5 ^{+0.1} ₋₀)	1.713 ^{+0.004} ₋₀ (43.5 ^{+0.1} ₋₀)
	D1	0.625 ^{+0.002} ₋₀ (15.87 ^{+0.05} ₋₀)	0.750 ^{+0.002} ₋₀ (19.05 ^{+0.05} ₋₀)	0.937 ^{+0.002} ₋₀ (23.80 ^{+0.05} ₋₀)	1.126 ^{+0.002} ₋₀ (28.60 ^{+0.05} ₋₀)	1.438 ^{+0.002} ₋₀ (36.52 ^{+0.05} ₋₀)
	D2	0.562 ^{+0.002} ₋₀ (14.27 ^{+0.05} ₋₀)	0.688 ^{+0.002} ₋₀ (17.47 ^{+0.05} ₋₀)	0.875 ^{+0.002} ₋₀ (22.22 ^{+0.05} ₋₀)	1.100 ^{+0.002} ₋₀ (28.00 ^{+0.05} ₋₀)	1.313 ^{+0.002} ₋₀ (33.35 ^{+0.05} ₋₀)
	E	0.102 ^{+0.012} ₋₀ (2.6 ^{+0.3} ₋₀)	0.102 ^{+0.012} ₋₀ (2.6 ^{+0.3} ₋₀)	0.130 ^{+0.012} ₋₀ (3.3 ^{+0.3} ₋₀)	0.130 ^{+0.012} ₋₀ (3.3 ^{+0.3} ₋₀)	0.134 ^{+0.012} ₋₀ (3.4 ^{+0.3} ₋₀)
	F	0.472 (12)	0.512 (13)	0.827 (21)	0.650 (16.5)	0.787 (20)
	G	0.315 (8)	0.551 (14)	0.551 (14)	0.591 (15)	1.102 (28)
	G1	0.118 (3)	0.158 (4)	0.197 (5)	0.197 (5)	0.276 (7)
	G2	0.472 (12)	0.591 (15)	0.748 (19)	0.945 (24)	1.181 (30)
	H1	0.492 (12.5)	0.551 (14)	0.889 (22.5)	0.689 (17.5)	0.787 (20)
	H2	0.807 (26.5)	1.240 (31.5)	1.595 (40.5)	1.496 (38)	1.969 (50)
	L1	0.630 (16)	0.709 (18)	1.043 (26.5)	0.866 (22)	1.004 (25.5)
	L2	1.260 (32)	1.575 (40)	1.949 (49.5)	1.870 (47.5)	2.579 (65.5)
	L3	1.575 (40)	1.929 (49)	2.362 (60)	2.284 (58)	3.071 (78)
	M	-	-	-	0.079 (2)	-
M1	-	-	-	0.079 (2)	-	

TOOLS (ALUMINIUM/STEEL *)	ORDERING CODE				
DRILL 	\varnothing G2	\varnothing G2	\varnothing G2	\varnothing G2	\varnothing G2
FORM DRILL 	P-CA-08A-3C	P-CA-10A-3C	P-CA-12A-3C	P-CA-16A-3C	P-CA-20A-3C
FORM REAMER 	A-CA-08A-3C	A-CA-10A-3C	A-CA-12A-3C	A-CA-16A-3C	A-CA-20A-3C
PLUG TAP 	M-CA-08A	M-CA-10A	M-CA-12A	M-CA-16A	M-CA-20A

* NOTE: Special heavy duty tools are available upon request, for steel drilling.



inches (mm)

STANDARD CAVITIES - TOOLS

FOUR WAY		CA-08A-4N	CA-10A-4N	CA-12A-4N	CA-16A-4N	CA-20A-4N
A	3/4-16 UNF-2B	7/8-14 UNF-2B	1-1/16 12 UN-2B	1-5/16 12 UN-2B	1-5/8 12 UN-2B	
B	1.024 (26)	1.118 (30)	1.118 (35)	1.118 (42)	1.890 (48)	
C	0.811 ^{+0.004} ₋₀ (20.6 ^{+0.1} ₋₀)	0.941 ^{+0.004} ₋₀ (23.9 ^{+0.1} ₋₀)	1.150 ^{+0.004} ₋₀ (29.2 ^{+0.1} ₋₀)	1.398 ^{+0.004} ₋₀ (35.5 ^{+0.1} ₋₀)	1.713 ^{+0.004} ₋₀ (43.5 ^{+0.1} ₋₀)	
D1	0.625 ^{+0.002} ₋₀ (15.87 ^{+0.05} ₋₀)	0.750 ^{+0.002} ₋₀ (19.05 ^{+0.05} ₋₀)	0.937 ^{+0.002} ₋₀ (23.80 ^{+0.05} ₋₀)	1.126 ^{+0.002} ₋₀ (28.60 ^{+0.05} ₋₀)	1.438 ^{+0.002} ₋₀ (36.52 ^{+0.05} ₋₀)	
D2	0.562 ^{+0.002} ₋₀ (14.27 ^{+0.05} ₋₀)	0.688 ^{+0.002} ₋₀ (17.47 ^{+0.05} ₋₀)	0.875 ^{+0.002} ₋₀ (22.22 ^{+0.05} ₋₀)	1.063 ^{+0.002} ₋₀ (27.00 ^{+0.05} ₋₀)	1.313 ^{+0.002} ₋₀ (33.35 ^{+0.05} ₋₀)	
D3	0.500 ^{+0.002} ₋₀ (12.70 ^{+0.05} ₋₀)	0.625 ^{+0.002} ₋₀ (15.87 ^{+0.05} ₋₀)	0.812 ^{+0.002} ₋₀ (20.62 ^{+0.05} ₋₀)	1 ^{+0.002} ₋₀ (25.42 ^{+0.05} ₋₀)	1.250 ^{+0.002} ₋₀ (31.75 ^{+0.05} ₋₀)	
E	0.102 ^{+0.012} ₋₀ (2.6 ^{+0.3} ₋₀)	0.102 ^{+0.012} ₋₀ (2.6 ^{+0.3} ₋₀)	0.130 ^{+0.012} ₋₀ (3.3 ^{+0.3} ₋₀)	0.130 ^{+0.012} ₋₀ (3.3 ^{+0.3} ₋₀)	0.134 ^{+0.012} ₋₀ (3.4 ^{+0.3} ₋₀)	
F	0.512 (13)	0.591 (15)	0.748 (19)	0.787 (20)	0.866 (22)	
G	0.236 (6)	0.315 (8)	0.551 (14)	0.630 (16)	0.984 (25)	
G1	0.472 (12)	0.591 (15)	0.748 (19)	0.945 (24)	1.181 (30)	
H1	0.591 (15)	0.709 (18)	1.102 (28)	0.984 (25)	1.260 (32)	
H2	1.142 (29)	1.339 (34)	2.087 (53)	2.106 (53.5)	2.835 (72)	
H3	1.693 (43)	1.969 (50)	3.071 (78)	3.228 (82)	4.488 (114)	
L1	0.768 (19.5)	0.925 (23.5)	1.437 (36.5)	1.398 (35.5)	1.811 (46)	
L2	1.319 (33.5)	1.555 (39.5)	2.421 (61.5)	2.520 (64)	3.425 (87)	
L3	1.870 (47.5)	2.185 (55.5)	3.445 (87.5)	3.642 (92.5)	5.059 (128.5)	
L4	2.205 (56)	2.539 (64.5)	3.898 (99)	4.095 (104)	5.591 (142)	
M	-	-	-	-	-	
M1	-	-	-	-	-	
M2	-	-	-	-	-	

General tolerance : 0.012 (0.3 mm)

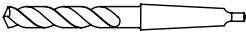
⊙ 0.002 (0.03)
 ⊥ 0.008 (0.02)

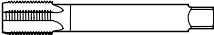
TOOLS (ALUMINIUM/STEEL *)	ORDERING CODE				
DRILL 	∅ G1	∅ G1	∅ G1	∅ G1	∅ G1
FORM DRILL 	P-CA-08A-4N	P-CA-10A-4N	P-CA-12A-4N	P-CA-16A-4N	P-CA-20A-4N
FORM REAMER 	A-CA-08A-4N	A-CA-10A-4N	A-CA-12A-4N	A-CA-16A-4N	A-CA-20A-4N
PLUG TAP 	M-CA-08A	M-CA-10A	M-CA-12A	M-CA-16A	M-CA-20A

* NOTE: Special heavy duty tools are available upon request, for steel drilling.

inches (mm)

SPECIAL CAVITIES

003

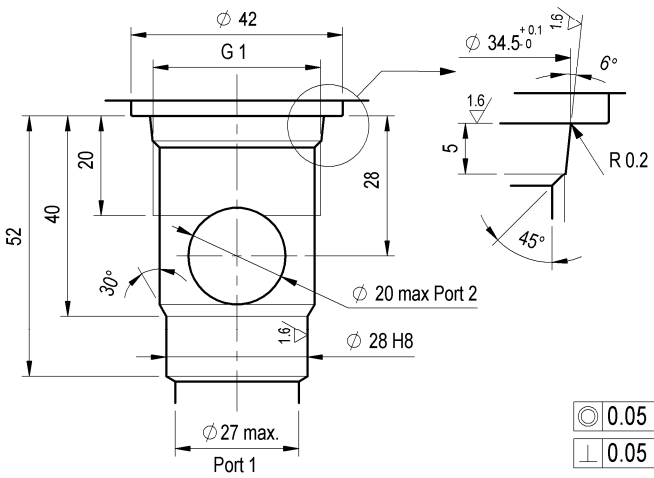

004

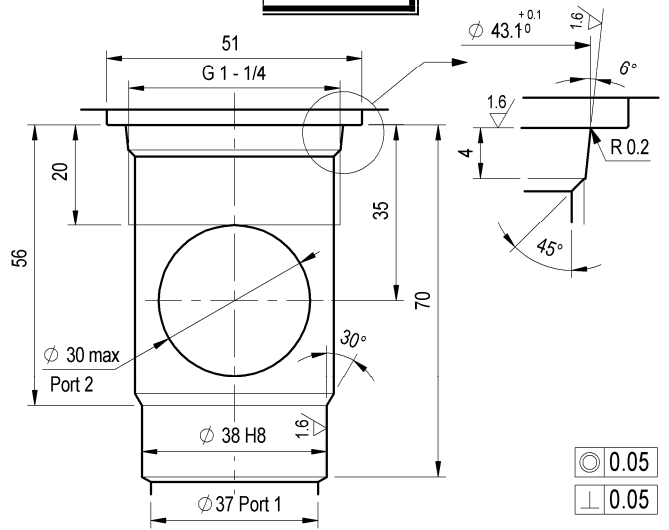

005

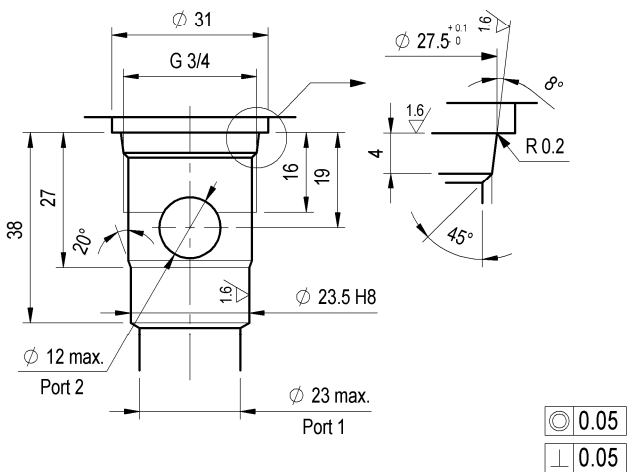

006

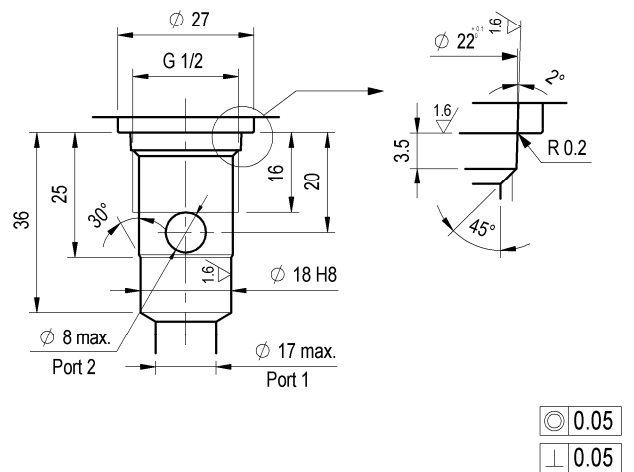

008

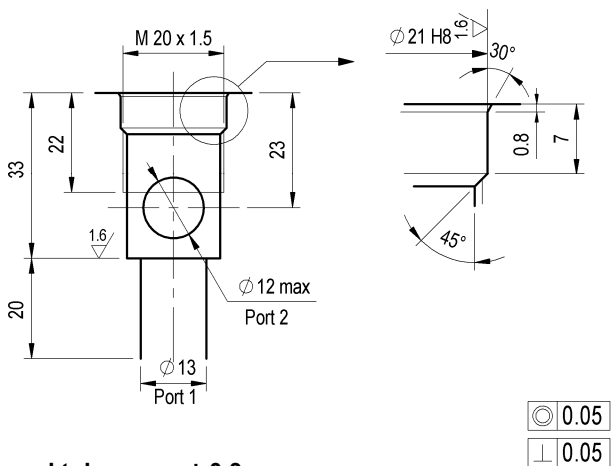

009

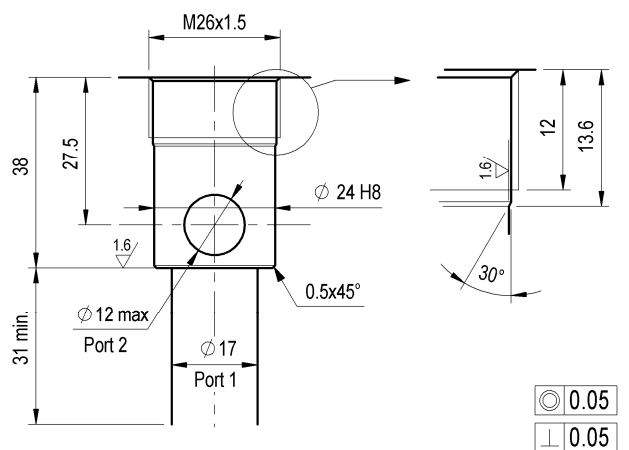

General tolerance : $\pm 0.3\text{mm}$

SPECIAL CAVITIES

033

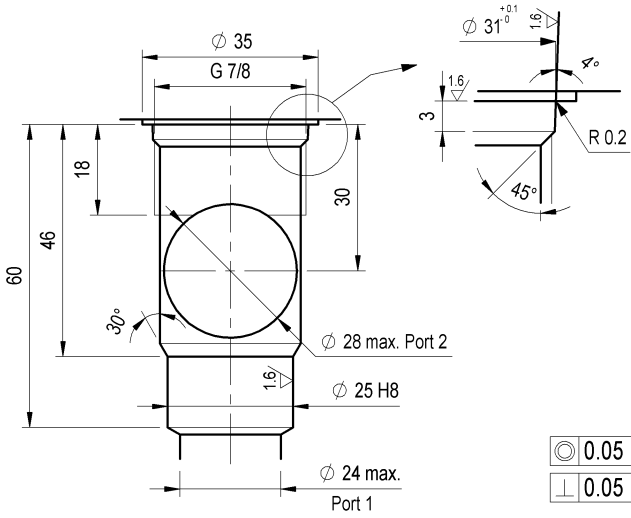

059

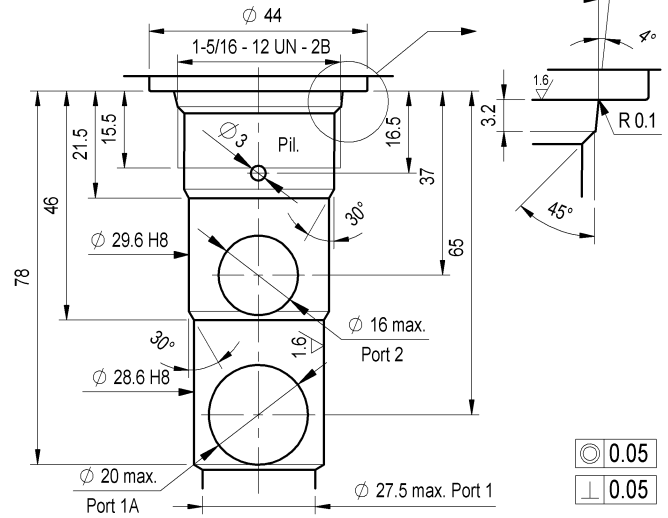

063

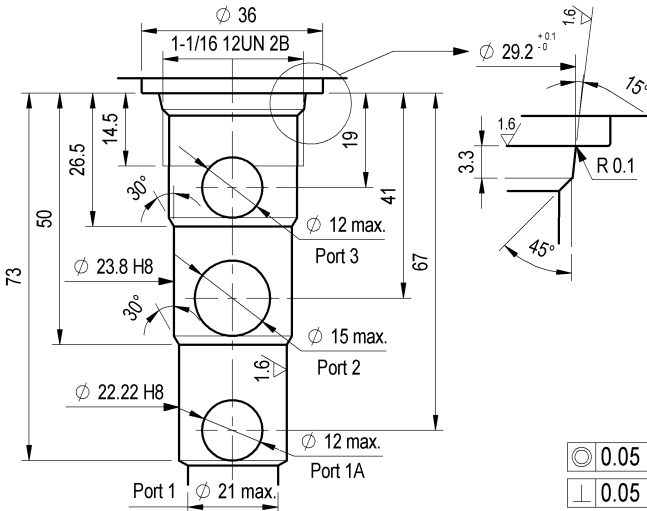

065

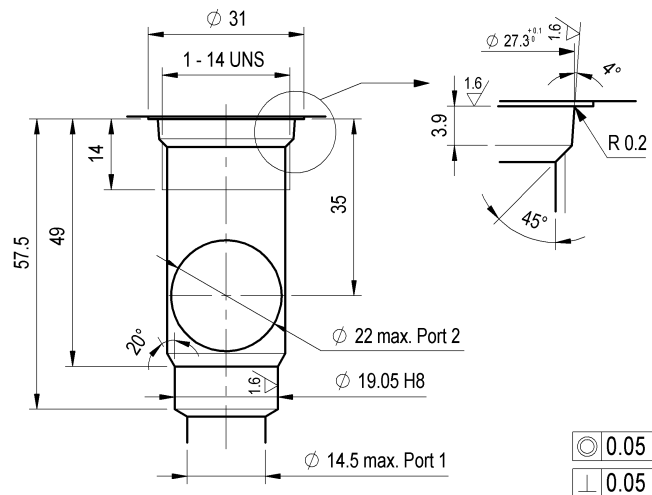

072

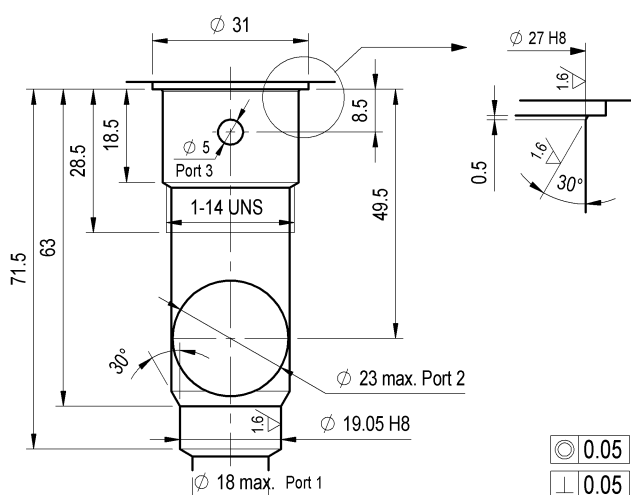

137

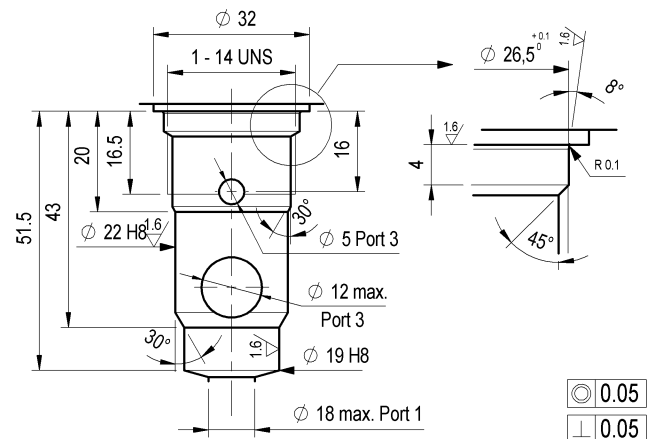



SPECIAL CAVITIES

348

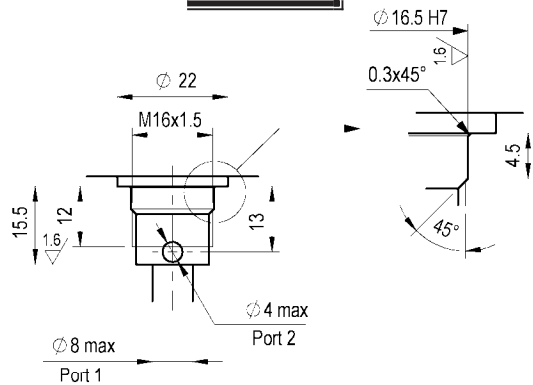

⊙ 0.05
⊥ 0.05

416

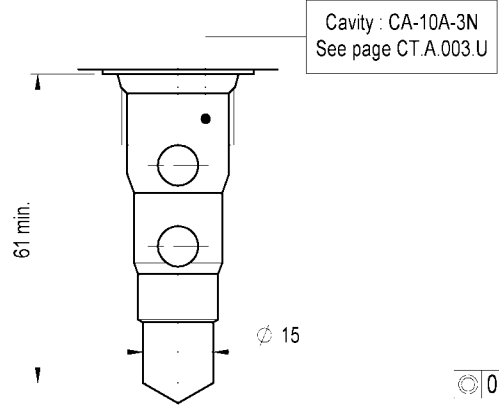

⊙ 0.05
⊥ 0.05

625

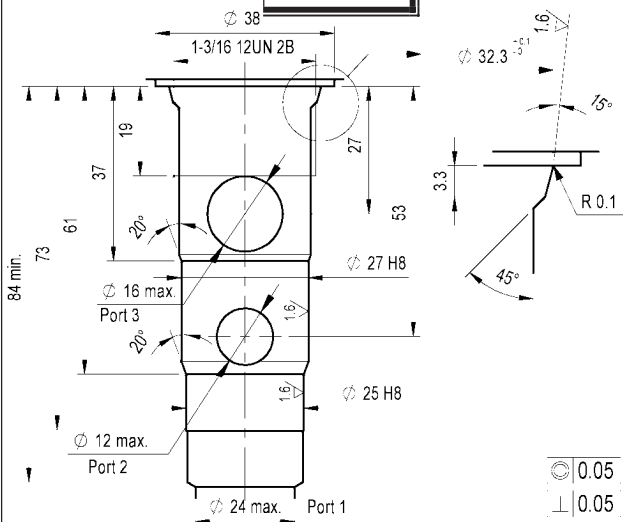

⊙ 0.05
⊥ 0.05

690

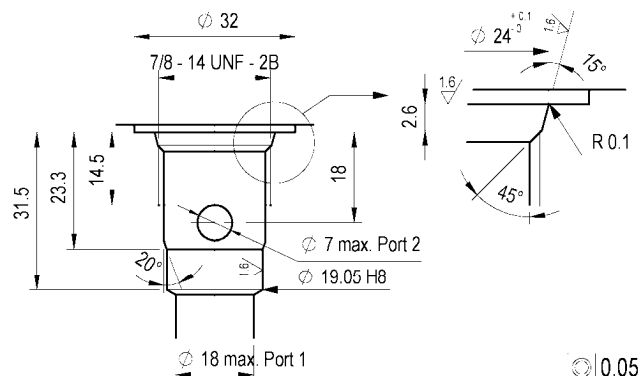

⊙ 0.05
⊥ 0.05

730

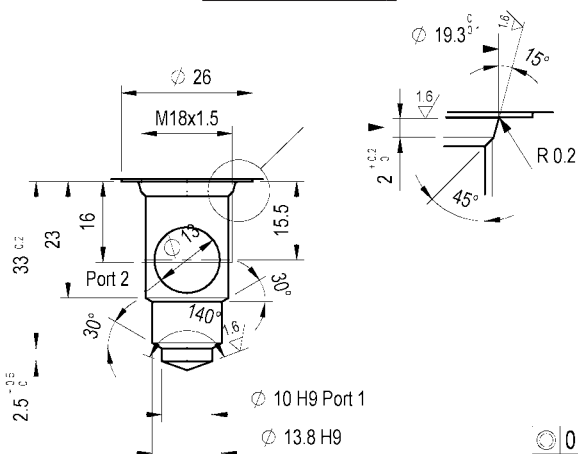

⊙ 0.05
⊥ 0.05

730-A

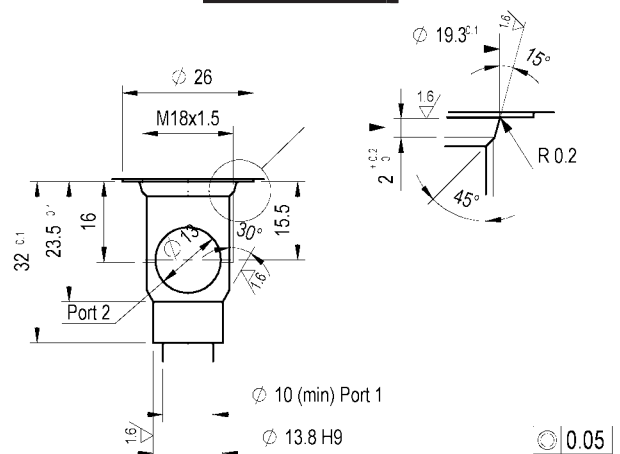

⊙ 0.05
⊥ 0.05

SPECIAL CAVITIES

771

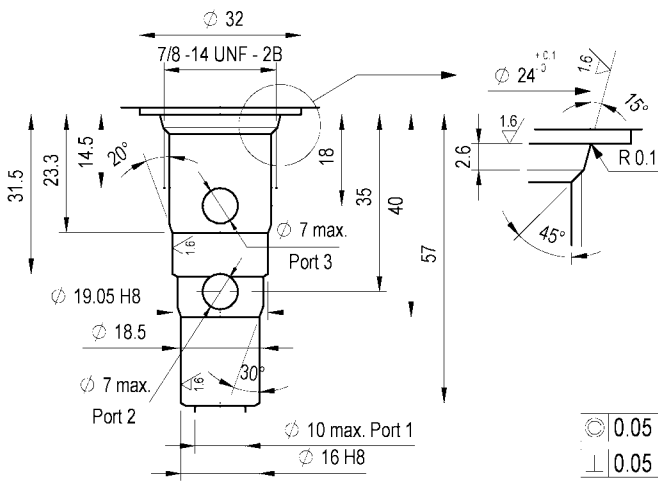

808

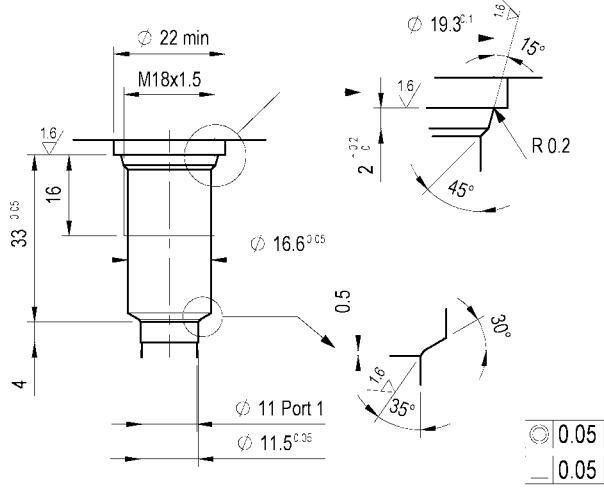

869

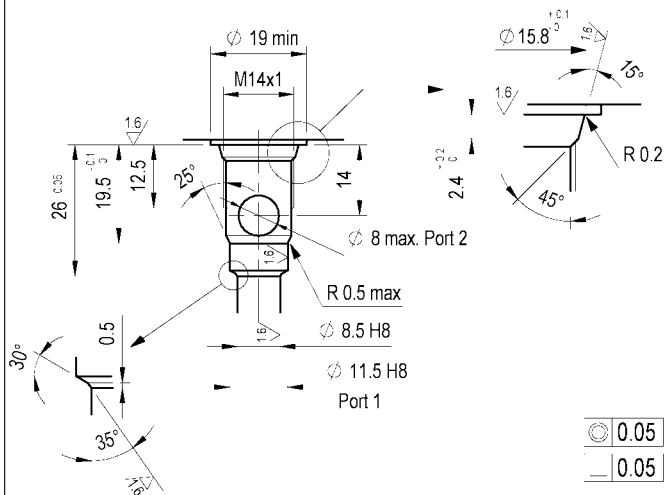

870

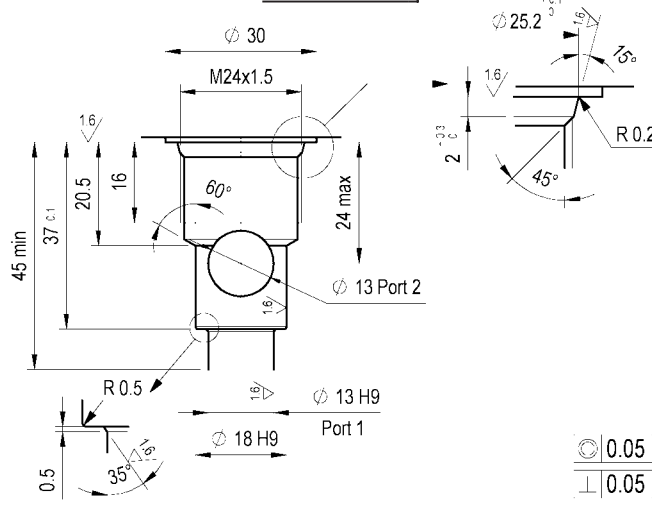

871

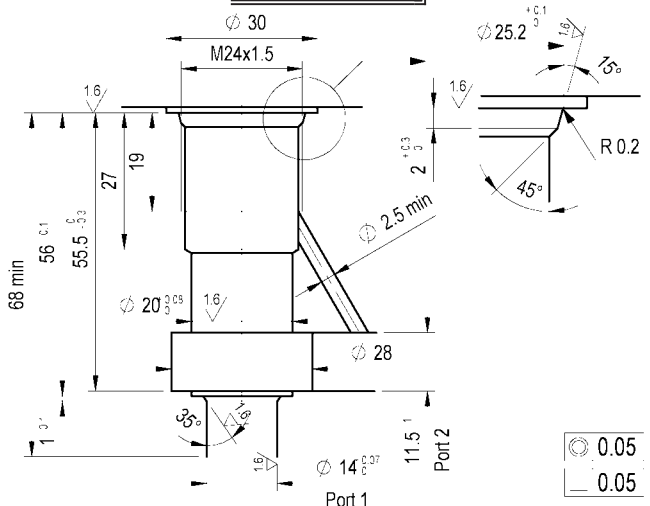

General tolerances : ± 0.3mm

Rev.0905



SPECIAL CAVITIES

CA-07A-3N

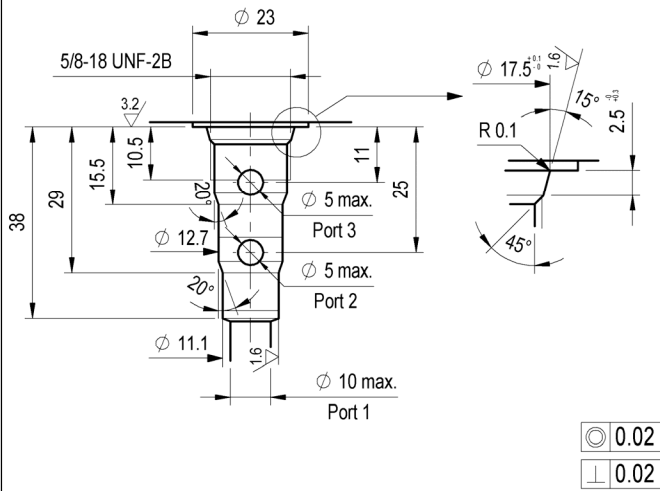

CC063A-01

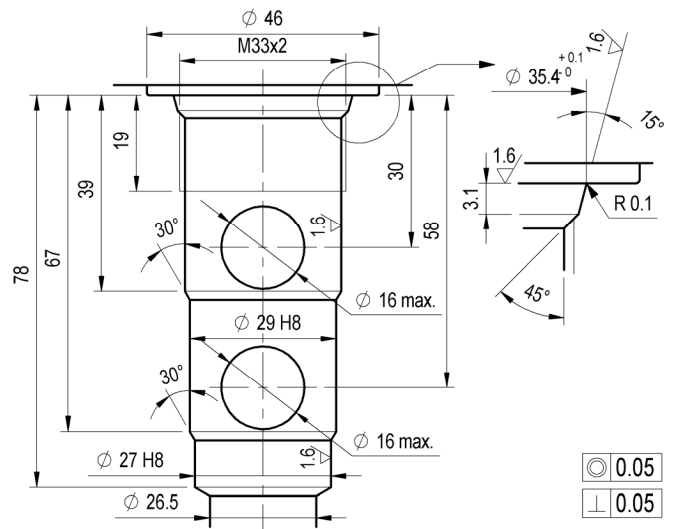

CD072A-01

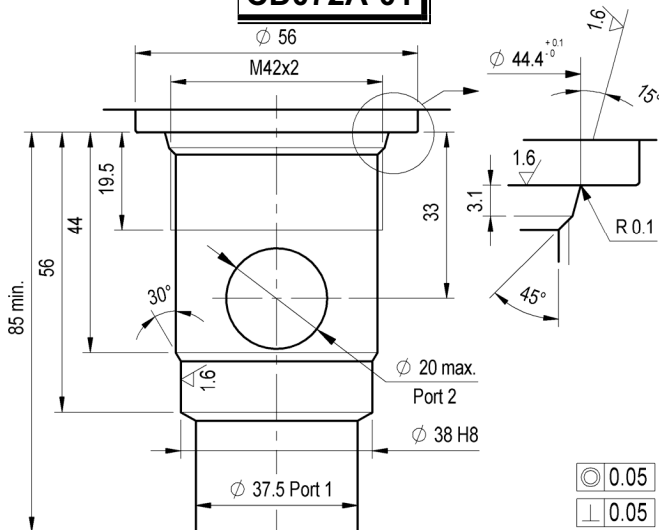

CD073A-01

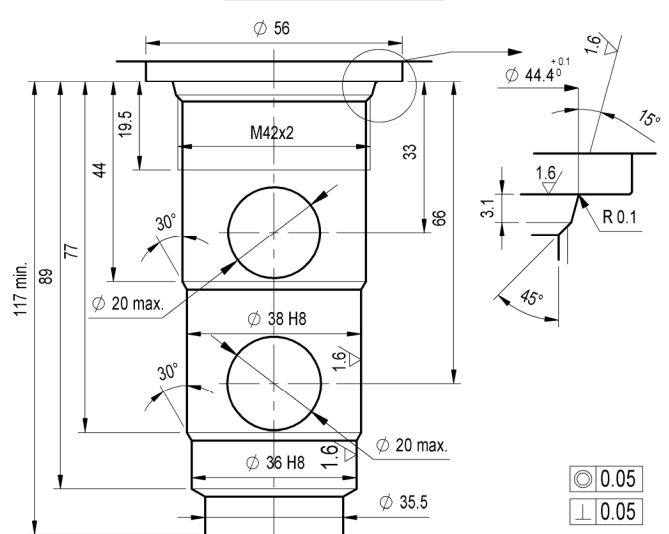

General tolerances : $\pm 0.3\text{mm}$

SPECIAL CAVITIES

017-E

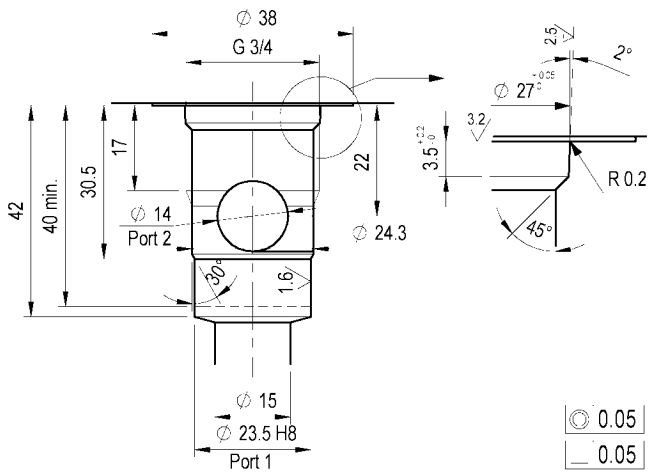

⊙	0.05
—	0.05

019-E

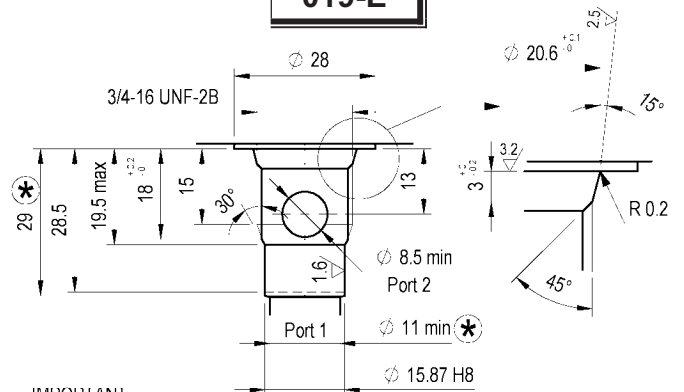

IMPORTANT!
 To assemble cartridges with internal revers check valve
 (VEI-8A-2A-06-VU etc.)

- ⊙ minimum diameter \varnothing 11 mm
- ⊙ minimum length 32 mm

⊙	0.05
	0.05

021-E

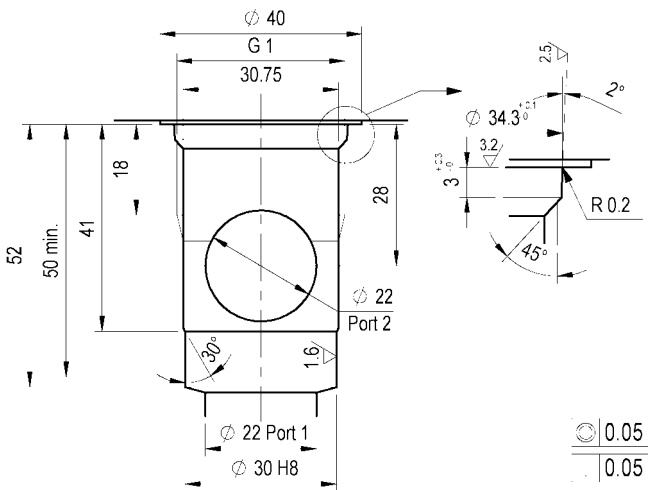

⊙	0.05
—	0.05

081-E

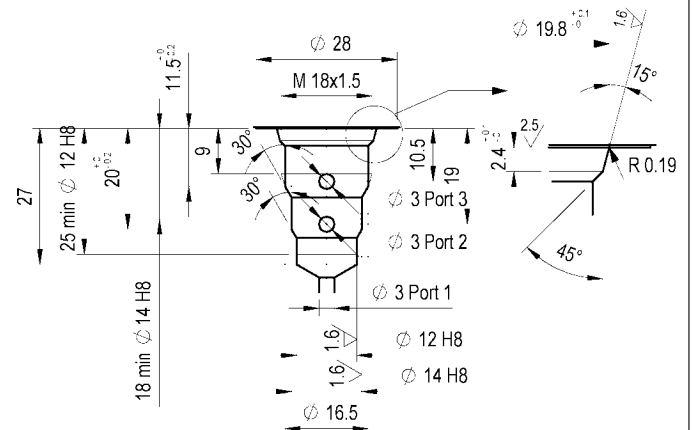

⊙	0.05
—	0.05

General tolerance : $\pm 0.3\text{mm}$

Group	BROC Catalog Code	BROC Ident	Denomination	Rexroth Code	Preferred Type	
Pressure Control Valves	VSNB-08A	04.11.49.03.56.10.000	relief, direct acting guided poppet type, common cavity	R90113599	X	
		04.11.49.03.56.20.000	relief, direct acting guided poppet type, common cavity	R90109728	X	
		04.11.49.03.56.35.000	relief, direct acting guided poppet type, common cavity	R901091914	X	
	VSNB-10A	04.11.55.03.85.10.000	relief, direct acting guided poppet type, common cavity	R90113609	X	
		04.11.55.03.85.20.000	relief, direct acting guided poppet type, common cavity	R90113610	X	
		04.11.55.03.85.35.000	relief, direct acting guided poppet type, common cavity	R90115702	X	
	VSBG-10A	04.11.56.03.85.10.000	relief, direct acting guided poppet type, common cavity	R90113622	X	
		04.11.56.03.85.20.000	relief, direct acting guided poppet type, common cavity	R90113624	X	
		04.11.56.03.85.35.000	relief, direct acting guided poppet type, common cavity	R90113626	X	
	VNSG - 10A	04.11.59.03.85.10.000	relief, bidirectional, direct acting poppet type differential area, common cavity	R90109725		
		04.11.59.03.85.20.000	relief, bidirectional, direct acting poppet type differential area, common cavity	R90109726		
	VSPN - 10A	04.12.08.03.85.20.000	relief, pilot operated, spool type, common cavity	R90109722		
		04.12.08.03.85.35.000	relief, pilot operated, spool type, common cavity	R901104103		
	VSPY - 10A	04.13.05.03.85.10.000	pilot operated sequence valve, spool type, external drain, common cavity	R901106472	X	
		04.13.05.03.85.20.000	pilot operated sequence valve, spool type, external drain, common cavity	R901097730		
	VRPP - 10A	04.93.06.03.85.10.000	pressure reducing, pilot operated, spool type, common cavity	R901104112	X	
	VRPX - 10A	04.93.07.03.85.10.000	pressure reducing and relieving, pilot operated spool type, common cavity	R901104118		
		04.95.04.03.85.02.00A	pressure reducing and relieving, direct acting spool type, common cavity	R90109740		
	VRPR - 10A	04.95.04.03.85.04.00A	pressure reducing and relieving, direct acting spool type, common cavity	R901102333	X	
		04.95.04.03.85.08.00A	pressure reducing and relieving, direct acting spool type, common cavity	R90109742	X	
Special Valves	VFN1	0TF4.01.03.03.00.000	hose burst	R901127828		
		0TF4.01.03.09.00.000	hose burst	R931000021		
		0TF4.01.03.04.00.000	hose burst	R901161819		
		0TF4.01.03.02.00.000	hose burst	R931000017		
Check Valves	VUH1	0TU5.01.00.03.00.000	check, poppet type	R901087794		
		0TU5.01.00.02.00.000	check, poppet type	R901064101		
	VSON - 08A	04.33.06.00.56.00.000	pilot operated check, common cavity	R901106627	X	
	VSON - 10A	04.33.05.00.85.00.000	pilot operated check, common cavity	R901106629	X	
	VSON - 12A	04.33.07.00.57.00.000	pilot operated check, common cavity	R901092653	X	
	VSON - 16A	04.33.08.00.27.00.000	pilot operated check, common cavity	R901106635		
	VUCN - 08A	04.31.20.00.56.00.000	check poppet type, 1 bar cracking, common cavity	R901007308	X	
		04.31.20.00.56.05.000	check poppet type, 5 bar cracking, common cavity	R901106550	X	
	VUCN - 10A	04.31.23.00.85.00.000	check poppet type, 1 bar cracking, common cavity	R901106596	X	
		04.31.23.00.85.05.000	check poppet type, 5 bar cracking, common cavity	R901106601	X	
	VUCN - 12A	04.31.28.00.57.00.000	check poppet type, 1 bar cracking, common cavity	R901106613	X	
		04.31.28.00.57.05.000	check poppet type, 5 bar cracking, common cavity	R901106614	X	
	VUCN - 16A	04.31.25.00.27.00.000	check poppet type, common cavity	R901106616		
	Counterbalance Valves	VBSN - 08AA	04.52.20.03.56.20.000	counterbalance, std, guided poppet type, common cavity	R901095960	
			04.52.20.03.56.35.000	counterbalance, std, guided poppet type, common cavity	R901095961	
		VBSN - 10A	04.52.31.03.85.35.000	counterbalance, std, poppet type, diff area, 3:1, 140 - 350bar, common cavity	R901096037	
04.52.31.03.85.20.000			counterbalance, std, poppet type, diff area, 3:1, 70 - 210bar, common cavity	R901096029	X	
VBSN - 12A		04.52.28.03.57.35.000	counterbalance, std, poppet type, diff area, 4:1, 140 - 350bar, common cavity	R901096044		
		04.52.28.03.57.20.000	counterbalance, std, poppet type, diff area, 4:1, 70 - 210bar, common cavity	R901096043	X	
VBSN - 16A		04.52.29.03.27.35.000	counterbalance, std, poppet type, diff area, 4:1, 140 - 350bar, common cavity	R901096048		
	04.52.29.03.27.20.000	counterbalance, std, poppet type, diff area, 4:1, 70 - 210bar, common cavity	R901096047			
Flow Control Valves	STVU - 08A	04.01.02.03.56.00.000	needle restrictor with free reverse flow, common cavity	R901109368	X	
		04.01.02.04.56.00.000	needle restrictor, free reverse flow, common cavity	R901109839		
	VRFB-10A	04.02.02.04.85.40.000	flow control, 2-way pressure compensated, fully adjustable, common cavity	R901095981	X	
	VRFD-10		flow control, 3-way pressure compensated, combination type fully adjustable, common cavity	R901106675	X	
	DRFN - 10A	04.05.01.00.85.16.000	flow divider and combiner, common cavity	R901096083		
		04.05.01.00.85.30.000	flow divider and combiner, common cavity	R901096086		
		04.05.01.00.85.40.000	flow divider and combiner, common cavity	R901096087		
	ST - C - 06	OD.21.01.03.56.00.000	cartridge restrictor, common cavity	R901109366	X	
	ST - C - 10A	OD.21.01.03.36.00.000	cartridge restrictor, common cavity	R901109830	X	
OD.21.01.04.36.00.000		cartridge restrictor, common cavity	R901109831	X		
ST - C - 12A	OD.21.01.03.89.00.000	cartridge restrictor, common cavity	R901109832	X		
ST - C - 16A	OD.21.01.03.75.00.000	cartridge restrictor, common cavity	R901109837	X		
Logic Elements	VLST-10A	04.84.01.03.85.00.000	Logic Element, adjustable, 2-8 bar, common cavity	R901104079		
	VLST-16A	04.84.01.03.27.00.000	Logic Element, adjustable, 4-12 bar, common cavity	R901109372		
	VLST-20A	04.84.01.00.58.11.000	Logic Element, fixed setting, 11.5 bar, common cavity	R901109867		
	VLSP-10A	04.84.03.03.85.00.000	Logic Element, adjustable, 2-8 bar, common cavity	R901109375		
	VLSP-16A	04.84.03.03.27.00.000	Logic Element, adjustable, 4-12 bar, common cavity	R901109871		
	VCSQ - 16A	04.84.06.00.27.06.000	logic element, pressure compensator, combination type, common cavity	R901162013		
	VDSQ - 10A	04.77.22.00.85.05.000	directional spool type, direct acting external pilot, external vented, common cavity	R901109495		
Directional Valves, Mechanically Operated.	VDP-32	OD.71.01.51.01.00.000	directional control valves, hydraulic automatic switching, spool 3-way 2-position cartridge style, special cavity	R979015064	X	
		OD.71.01.51.02.00.000	directional control valves, hydraulic automatic switching, spool 3-way 2-position cartridge style, special cavity	R979015065	X	
		OD.71.01.51.04.00.000	directional control valves, hydraulic automatic switching, spool 3-way 2-position cartridge style, special cavity	R979015066	X	
Shuttle Valves	VFC	05.99.05.00.09.00.00A	shuttle	05990500090000A	X	
	SELB - 08A	04.94.05.00.56.00.000	shuttle, common cavity	R901161981	X	
Solenoid Valves	VED-8I-32-06-SE	OD.13.10.51.30.00.000	solenoid operated valves, spool 3-way 2-position, common cavity	R901126871	X	
		OD.13.10.51.40.00.000	solenoid operated valves, spool 3-way 2-position, common cavity	R901126872	X	
	VED-8I-32-06-SI	OD.13.11.51.30.00.000	solenoid operated valves, spool 3-way 2-position, common cavity	R901126873	X	
		OD.13.20.51.30.00.000	solenoid operated valves, spool 3-way 2-position, common cavity	R901126892	X	
	VED-8I-42-06-CA	OD.14.40.58.30.00.000	solenoid operated valves, spool 4-way 2-position, common cavity	R901113693		
	VED-8I-43-06-ABT	OD.14.32.58.44.00.000	solenoid operated valves, spool 4-way 3-position, common cavity	R901113705		
	VEI - 8A - 2A - 06 - NA - S - NSS	OD.15.06.18.1A.S0.000	2/2 poppet directional valve, normally open, both way, common cavity	R901091130	X	
	VEI - 8A - 2A - 06 - NC - S - X - NSS	OD.15.05.18.3A.S8.000	2/2 poppet directional valve, normally closed, extra spring, both way, common cavity	R934003080		
	VEI - 8A - 2A - 09 - NA - S - NSS	OD.15.06.17.1A.S0.000	2/2 poppet directional valve, normally open, both way, special cavity	R901113677		
	VEI - 8A - 2A - 09 - NC - S - X - NSS	OD.15.05.17.3A.S8.000	2/2 poppet directional valve, normally closed extra spring, both way, special cavity	R901119220		
	VEI - 8A - 2A - 10A - NA - S - NSS	OD.15.06.36.1A.S0.000	2/2 poppet directional valve, normally open, both way, common cavity	R901080489		
	VEI - 8A - 2A - 10A - NC - S - NSS	OD.15.05.36.3A.S0.000	2/2 poppet directional valve, normally closed, both way, common cavity	R901090947	X	
	VEI - 8A - 2A - 10A - NC - S - X - NSS	OD.15.05.36.3A.S8.000	solenoid operate valves, poppet 2 way normally closed, extra spring, common cavity	R901090945	X	
	VEI - 8A - 2A - 12 - NA - S - NSS	OD.15.06.21.1A.S0.000	2/2 poppet directional valve, normally open, extra spring, both way, special cavity	R901104409		
	VEI - 8A - 2A - 12 - NC - S - X - NSS	OD.15.05.21.3A.S8.000	2/2 poppet directional valve, normally closed, extra spring, both way, special cavity	R901119221		
	VEI - 8A - 2A - 12A - NA - S - NSS	OD.15.06.89.1A.S0.000	2/2 poppet directional valve, normally open, both way, common cavity	R901091139		
VEI - 8A - 2A - 12A - NA - S - NSS	OD.15.06.89.1A.S0.001	2/2 poppet directional valve, normally open, both way, common cavity	R901091140			
VEI - 8A - 2T - 06 - NA - S - NSS	OD.15.32.18.1A.S0.000	2/2 poppet directional valve, normally open, double lock, both way, common cavity	R901091171			
VEI - 8A - 2T - 06 - NC - S - NSS	OD.15.31.18.3A.S0.000	2/2 poppet directional valve, normally closed, double lock, both way, common cavity	R901082015	X		
VEI-8I-2A-06-NC-S-NSS	OD.15.05.18.3I.S0.000	solenoid operated valves, poppet 2-way normally closed, common cavity	R901090953			
VEI-8I-2A-06-NC-S1-NSS	OD.15.01.18.3I.S0.000	2/2 poppet directional valve, normally closed, one way, common cavity	R901090962	X		
VEI-8I-2A-06-NC-S1-NSS, N9	OD.15.01.18.3M.S0.000	solenoid operated valves, poppet 2-way normally closed, common cavity	R901090966	X		
Coils	S8 - 356	OD.02.17.01.30.OC.000	coil, 24VDC, Hirschmann	R901083065	X	
		OD.02.17.01.30.OB.000	coil, 12VDC, Hirschmann	R901090821	X	
		OD.02.17.01.30.OW.000	coil, 110 V RAC	R901087981	X	
		OD.02.17.01.30.OZ.000	coil, 220 V RAC, Hirschmann	R901085466	X	
		OD.02.17.20.30.OC.000	coil, 24VDC, Deutsch connector	R901094611	X	
		OD.02.17.20.30.OB.000	coil, 12VDC, Deutsch connector	R901094609	X	
Manifolds	Manifold	OC.10.09.00.40.00.000	manifold 2 way aluminum	R901082022		

Cartridge Valves - RC X BROC

BR RC Brazil		BR Oil Control			Cavity Interchange?	Note
Group 01						
BRBR Code	Directional	SAP Code	Description	BROC Code		
44002803	RCSS2SE8K10M	R901090962 R901090966	OD.15.01.18.3I.S0.000 OD.15.01.18.3M.S0.000	VEI-8A-2A-06-NC-S1-NSS VEI-8I-2A-06-NC-S1-NSS, N9	No No	simple restraint A to B - 30 L/min simple restraint A to B - 30 L/min + Manual Ove
Group 02						
BRBR Code	Directional	SAP Code	Description	BROC Code		
44005503	RCEE4WE8K10M	---	---	---		Valve without consumption
44005803	RCEX2WH8GA10M	---	---	---		Valve without consumption
44005703	RCEX2WH8K10M	---	---	---		Valve+housing without consumption
44002603	RCSC2SE8K10M	---	---	---		Valve without consumption
Group 03						
BRBR Code	Flow	SAP Code	Description	BROC Code		
43048503	RC2FP10K110M*-SO417565	---	---	---		Valve without consumption
43048103	RC2FP10K110MA	---	---	---		Valve without consumption
43048403	RC2FP10K110MB	---	---	---		Valve without consumption
43052503	RC2FP10K110MC	R901106675	04.04.02.04.85.40.000	VRFD-10	Yes	Totally adjustable (0 - 30 Lpm)
43105303	RC3MK10KE10M	R901109368	04.01.02.03.56.00.000	STVU-08A	No	
43105503	RC3MK10KM10M	R901109839	04.01.02.04.56.00.000	STVU-08A	No	
44005403	RCEB2WE8K10M	---	---	---		Valve without consumption
Group 04						
BRBR Code	Flow - Sequence	SAP Code	Description	BROC Code		
43219503	RC1DZ10KE10AM	---	---	---		Valve without consumption
43219603	RC1DZ10KE10BM	---	---	---		Valve without consumption
43219803	RC1DZ10KE10CM	R901106472	04.13.05.03.85.10.000	VSPY-10A	Yes	
43218703	RC1DZ10KE10DM	R901106472	04.13.05.03.85.10.000	VSPY-10A	Yes	
43017603	RC1F8KM10M	R901109366	OD.21.01.03.56.00.000	STC-06	Yes	
Group 05						
BRBR Code	Flow	SAP Code	Description	BROC Code		
43018503	RC2FC8K110AM	R901095981	04.02.02.04.85.40.000	VRFB-10A	Yes	
43162903	RC2FC8K110BM	---	---	---		Valve without consumption
43163403	RC2FC8K110CM	R901095981	04.02.02.04.85.40.000	VRFB-10A	Yes	
Group 06						
BRBR Code	Pressure	SAP Code	Description	BROC Code		
43218603	RC1DR10K110*M-SO41-7564	---	---	---		Valve without consumption
43204603	RC1DR10K110AM	---	---	---		Valve without consumption
43204703	RC1DR10K110BM	R901109742	04.95.04.03.85.08.000	VRPR-10A	Yes	
43204803	RC1DR10K110CM	---	---	---		Valve without consumption
43018003	RC1DR10K110DM	---	---	---		Valve without consumption
Group 07						
BRBR Code	Isolator - Check	SAP Code	Description	BROC Code		
43219003	RC1SV8K10AM	R901106627	04.33.06.00.56.00.00A	VSON-08A	Yes	
43219703	RC1SV8K10BM	---	---	---		Valve without consumption
43210003	RC1SV10K10AM	R901106629	04.33.05.00.85.00.00A	VSON-10A	No	
43210103	RC1SV10K10BM	---	---	---		Valve without consumption
BR RC Brazil						
Group 08						
BRBR Code	Directional	SAP Code	Description	BROC Code		
F000530013	RCEC3WE8GA10M/24V	---	---	---		Valve without consumption
44005303	RCEC3WE8K10M	R901126871 R901126872	OD.13.10.51.30.00 OD.13.10.51.40.00	VED-8I-32-06-SE VED-8I-32-06-SE	Yes Yes	
44005603	RCEC3WH8K10M	---	---	---		Valve without consumption
44005903	RCEC3WH8KI20AM	---	---	---		Valve without consumption
44006003	RCEC3WH8KI20BM	R979015064 R979015065 R979015066	OD.71.01.51.01 OD.71.01.51.02 OD.71.01.51.04	VDP-32 VDP-32 VDP-32	Yes Yes Yes	Switching pressure 03 - 25 Bar Switching pressure 20 - 60 Bar Switching pressure 70 - 100 Bar
Group 09						
BRBR Code	Directional	SAP Code	Description	BROC Code		
43105403	RC1AT8K10M VAL. ALTERNADO	R901161981	04.94.05.00.56.00.000	SELB-08A	Yes	
Group 10						
BRBR Code	Pressure	SAP Code	Description	BROC Code		
43167203	RC1DB10KE10AM 70BAR	---	---	---		Valve without consumption
43167303	RC1DB10KE10BM	---	---	---		Valve without consumption
43167403	RC1DB10KE10CM	---	---	---		Valve without consumption
43217503	RC1DB10K110AM 70BAR	---	---	---		Valve without consumption
43217603	RC1DB10K110BM 140BAR	---	---	---		Valve without consumption
43222203	RC1DB10K110BV 140BAR	---	---	---		Valve without consumption
43214403	RC1DB10K110CM 250BAR	R901113622 R901113624 R901113626	04.11.56.03.85.10.000 04.11.56.03.85.20.000 04.11.56.03.85.35.000	VSBG-10A VSBG-10A VSBG-10A	Yes Yes Yes	Pressure range 35 - 140 Bar Pressure range 105 - 210 Bar Pressure range 175 - 350 Bar
Group 11						
BRBR Code	Pressure	SAP Code	Description	BROC Code		
43018103	RC1DB8K10AM 70BAR	R901113622	04.11.56.03.85.10.000	VSBG-10A	No	Pressure range 35 - 140 Bar
43217203	RC1DB8K10BM 140BAR	R901113624	04.11.56.03.85.20.000	VSBG-10A	No	Pressure range 105 - 210 Bar
43017103	RC1DB8K10CM 250BAR	R901113626	04.11.56.03.85.35.000	VSBG-10A	No	Pressure range 175 - 350 Bar
Group 12						
BRBR Code	Isolator - Check	SAP Code	Description	BROC Code		
43217903	RC1S10K10AM RET. 0.35BAR	R901106596	04.31.23.00.85.00	VUCN-10A	Yes	Cracking pressure 0.5 Bar
43214503	RC1S10K10BM RET. 1.0BAR	R901106596	04.31.23.00.85.00	VUCN-10A	Yes	Cracking pressure 0.5 Bar
43223303	RC1S10K10AV RET. 0.35BAR	---	---	---		Valve without consumption
43218003	RC1S10K10CM RET. 4.5BAR	R901106601	04.31.23.00.85.05	VUCN-10A	Yes	Cracking pressure 5 Bar
Group 13						
BRBR Code	Isolator - Check	SAP Code	Description	BROC Code		
43041103	RC1S8K10AM RET. 0.35BAR	R901007308	04.31.20.00.56-00	VUCN-08A	Yes	Cracking pressure 1 Bar
43217703	RC1S8K10BM RET. 1BAR	R901007308	04.31.20.00.56-00	VUCN-08A	Yes	Cracking pressure 1 Bar
43217803	RC1S8K10CM RET. 4.5BAR	R901106550	04.31.20.00.56-05	VUCN-08A	Yes	Cracking pressure 5 Bar
Group 14						
BRBR Code	Pressure	SAP Code	Description	BROC Code		
43167503	RC3DB10KE10AM	---	---	---		Valve without consumption
43167803	RC3DB10KE10AM SO41-7946	R901113609	04.11.55.03.85.10	VSBN-10A	Yes	
43167603	RC3DB10KE10BM	---	---	---		Valve without consumption
43167703	RC3DB10KE10CM	R901113609 R901113610 R901115702	04.11.55.03.85.10 04.11.55.03.85.20 04.11.55.03.85.35	VSBN-10A VSBN-10A VSBN-10A	Yes Yes Yes	
43217303	RC3DB10K110AM 70 BAR	---	---	---		Valve without consumption
43217403	RC3DB10K110BM 140 BAR	---	---	---		Valve without consumption
43214703	RC3DB10K110CM	R901113609 R901113610 R901115702	04.11.55.03.85.10 04.11.55.03.85.20 04.11.55.03.85.35	VSBN-10A VSBN-10A VSBN-10A	Yes Yes Yes	
BR RC Brazil						
Group 15						
BRBR Code	Pressure	SAP Code	Description	BROC Code		
43018203	RC3DB8K10AM 70BAR	---	---	---		Valve without consumption
43217103	RC3DB8K10BM 140BAR	R901113599 R901097728	04.11.49.03.56.10 04.11.49.03.56.20	VSBN-08A VSBN-08A	Yes Yes	
43017003	RC3DB8K10CM 250BAR	R901113599 R901097728 R901091914	04.11.49.03.56.10 04.11.49.03.56.20 04.11.49.03.56.35	VSBN-08A VSBN-08A VSBN-08A	Yes Yes Yes	