

Throttle and throttle check valve

Type MG and MK

RE 27219

Edition: 2018-10

Replaces: 01.09



H7793

- ▶ Size 6 ... 30
- ▶ Component series 1X
- ▶ Maximum operating pressure 315 bar
- ▶ Maximum flow 400 l/min

Features

- ▶ For pipeline installation
- ▶ Depending on viscosity and pressure
- ▶ Type MG: throttling in both directions of flow
- ▶ Type MK: throttling in one direction of flow, free flow in opposite direction
- ▶ Corrosion-protected design

Contents

Features	1
Ordering code	2
Symbols	2
Function, section	3
Technical data	4
Characteristic curves	5
Dimensions	6
Further information	6

Ordering code

01	02	03	04	05	06	07
		G	1X	/		*

01	Throttle valve	MG
	Throttle check valve	MK
02	Size 6	6
	Size 8	8
	Size 10	10
	Size 15	15
	Size 20	20
	Size 25	25
	Size 30	30
03	Threaded connection	G
04	Component series 10 ... 19 (10 ... 19: unchanged installation and connection dimensions)	1X

Corrosion resistance (outside)

05	None (valve housing primed)	no code
	Improved corrosion protection (240 h salt spray test according to EN ISO 9227)	J3
	Improved corrosion protection (720 h salt spray test according to EN ISO 9227)	J5

Seal material

06	NBR seals	no code
	FKM seals	V
	Observe compatibility of seals with hydraulic fluid used. (Other seals upon request)	
07	Further details in the plain text	*

Notes:

- ▶ For valve types for use in potentially explosive areas, refer to data sheet 07011.
- ▶ Preferred types and standard units are contained in the EPS (standard price list).

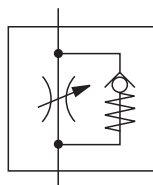
Symbols**Type MG****Type MK**

Function, section

The valve types MG and MK are pressure- and viscosity-dependent throttle and throttle check valves.

Type MG (throttle valve)

Throttling is realized in both directions of flow. The hydraulic fluid is directed to the throttling point (4) via lateral bores (3). It is formed between the housing (2) and the adjustable sleeve (1). By rotating the sleeve (1), the cross-section of the throttling point (4) can be continuously adjusted.

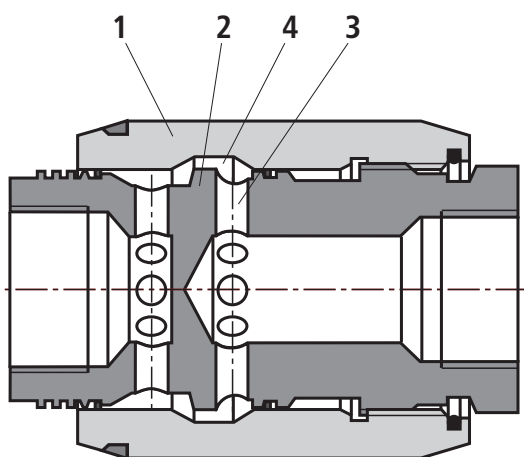

Type MG

Type MK (throttle check valve)

If the valve is passed by the flow in throttling direction, the spring (6) and the hydraulic fluid push the poppet (5) on the seat and the connection is blocked. Via lateral bores (3), the hydraulic fluid flow is directed to the throttling point (4) between the housing (2) and the adjustable sleeve (1).

In the opposite direction, the pressure acts on the front face of the poppet (5), lifts it from the seat and releases the flow. The hydraulic fluid flow is released through the valve without throttling. In this process, simultaneous passing of a part of the hydraulic fluid via the annular gap leads to the desired effect of self-cleaning.

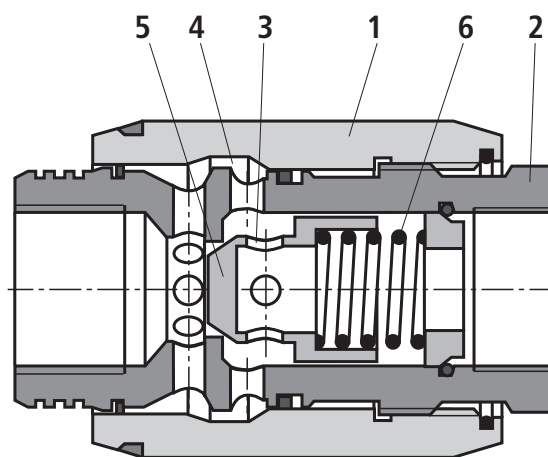

Type MK

Technical data

(for applications outside these values, please consult us!)

General									
Size		6	8	10	15	20	25	30	
Weight	kg	0.3	0.4	0.7	1.1	1.9	3.2	4.1	
Installation position		any							
Ambient temperature range	°C	-30 ... +80 (NBR seals) -20 ... +80 (FKM seals)							

hydraulic									
Maximum operating pressure	bar	315							
Cracking pressure (type MK)	bar	0.5							
Maximum flow	l/min	see characteristic curves on page 5							
Maximum leakage ¹⁾	▶ Standard	l/min	0.8	1.0	2.0	2.0	3.0	4.0	5.5
	▶ Version "J3" and "J5"	l/min	1.6	1.6	2.5	3.2	3.5	7.0	7.7
Hydraulic fluid		see table below							
Hydraulic fluid temperature range	°C	-30 ... +80 (NBR seals) -20 ... +80 (FKM seals)							
Viscosity range	mm ² /s	10 ... 800							
Maximum admissible degree of contamination of the hydraulic fluid; cleanliness class according to ISO 4406 (c)		Class 20/18/15 ²⁾							
Load cycles	▶ Size 6 ... 15	10 Mio.							
	▶ Size 20 ... 30	2 Mio.							

Hydraulic fluid	Classification	Suitable Sealing materials	Standards	Data sheet
Mineral oils	HL, HLP	NBR, FKM	DIN 51524	90220
Bio-degradable ³⁾	▶ Insoluble in water	HETG	ISO 15380	90221
		HEES		
	▶ Soluble in water	HEPG	ISO 15380	
Flame-resistant	▶ Water-free	HFDU (glycol base)	ISO 12922	90222
		HFDU (ester base) ³⁾		
		HFDR		
	▶ Containing water ³⁾	HFC (Fuchs Hydrotherm 46M, Fuchs Renosafe 500, Petrofer Ultra Safe 620, Houghton Houghto Safe 620, Union Carbide HP5046)	ISO 12922	90223

**Important information on hydraulic fluids:**

- ▶ For further information and data on the use of other hydraulic fluids, please refer to the data sheets above or contact us.
- ▶ There may be limitations regarding the technical valve data (temperature, pressure range, life cycle, maintenance intervals, etc.).
- ▶ The ignition temperature of the hydraulic fluid used must be 50 K higher than the maximum surface temperature.

▶ Flame-resistant – containing water:

- Maximum pressure differential 210 bar, otherwise, increased cavitation erosion
- Life cycle as compared to operation with mineral oil HL, HLP 30 ... 100%
- Maximum hydraulic fluid temperature 60 °C

- ▶ **Bio-degradable and flame-resistant:** If this hydraulic fluid is used, small amounts of dissolved zinc may get into the hydraulic system.

¹⁾ If valve is completely closed

²⁾ The cleanliness classes specified for the components must be adhered to in hydraulic systems. Effective filtration prevents faults and simultaneously increases the life cycle of the components.

Available filters can be found at www.boschrexroth.com/filter.

³⁾ Not recommended for corrosion-protected versions "J3" and "J5"

Characteristic curves

(measured with HLP46, $\vartheta_{oil} = 40 \pm 5 \text{ }^\circ\text{C}$)

Δp - q_v characteristic curves via open throttle (type MG and MK)

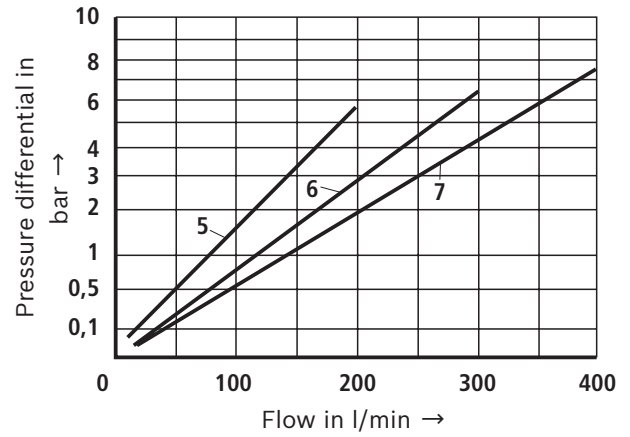
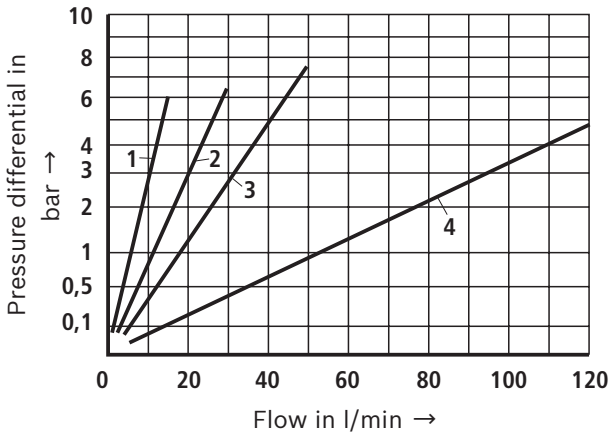

Δp - q_v characteristic curves via opened check valve at closed throttle (type MK)

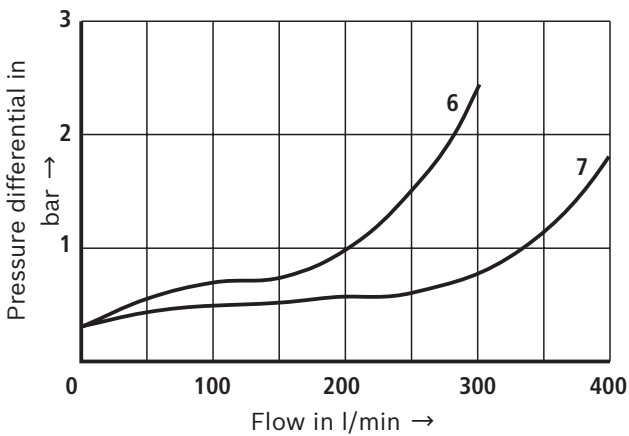
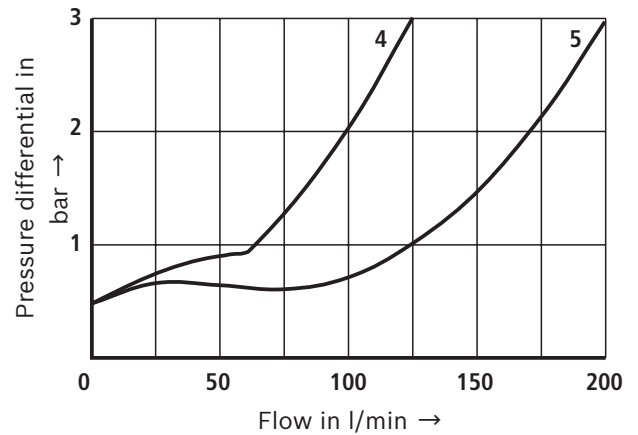
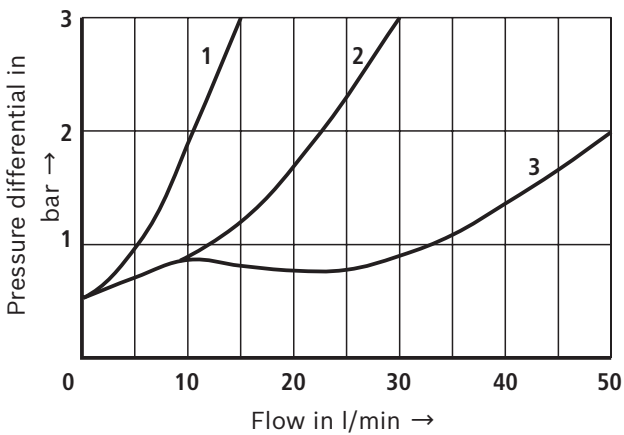

- 1 NG6
- 2 NG8
- 3 NG10
- 4 NG15
- 5 NG20
- 6 NG25
- 7 NG30

Dimensions

(dimensions in mm)

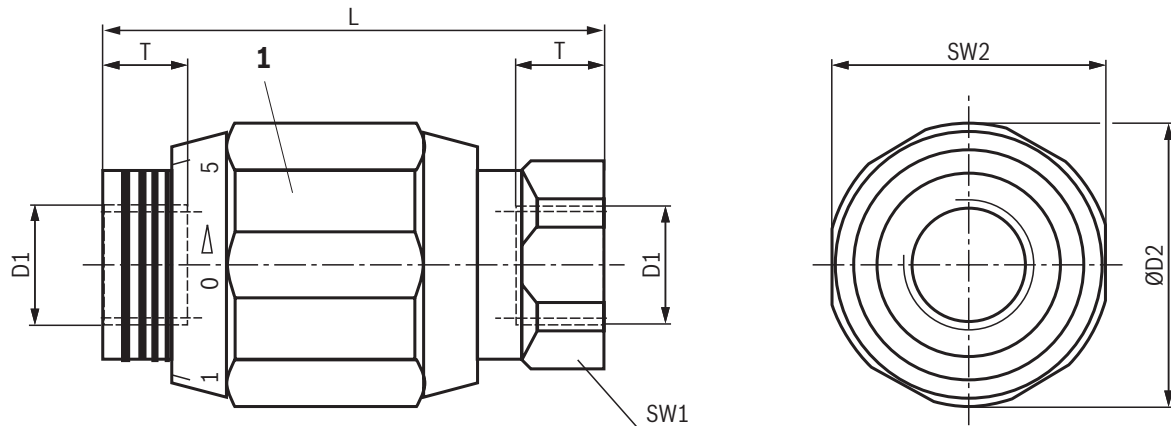
**1** Valve marking on key face

NG	D1	ØD2	L	SW1	SW2	T
6	G1/4	34	65	22	32	12
8	G3/8	38	65	24	36	12
10	G1/2	48	80	30	46	14
15	G3/4	58	100	41	55	16
20	G1	72	110	46	70	18
25	G1 1/4	87	130	55	85	20
30	G1 1/2	93	150	60	90	22

Further information

- ▶ Hydraulic fluids on mineral oil basis
- ▶ Environmentally compatible hydraulic fluids
- ▶ Flame-resistant, water-free hydraulic fluids
- ▶ Flame-resistant hydraulic fluids - containing water (HFAE, HFAS, HFB, HFC)
- ▶ Hydraulic valves for industrial applications
- ▶ General product information on hydraulic products
- ▶ Assembly, commissioning and maintenance of industrial valves
- ▶ Use of non-electrical hydraulic components in explosive atmospheres (ATEX)
- ▶ Selection of filters
- ▶ Information on available spare parts

Data sheet 90220
 Data sheet 90221
 Data sheet 90222
 Data sheet 90223
 Operating instructions 07600-B
 Data sheet 07008
 Data sheet 07300
 Data sheet 07011
www.boschrexroth.com/filter
www.boschrexroth.com/spc

Bosch Rexroth AG
 Industrial Hydraulics
 Zum Eisengießer 1
 97816 Lohr am Main, Germany
 Phone +49 (0) 93 52/40 30 20
my.support@boschrexroth.de
www.boschrexroth.de

© All rights reserved to Bosch Rexroth AG, also regarding any disposal, exploitation, reproduction, editing, distribution, as well as in the event of applications for industrial property rights.
 The data specified above only serve to describe the product. No statements concerning a certain condition or suitability for a certain application can be derived from our information. The information given does not release the user from the obligation of own judgment and verification.
 It must be remembered that our products are subject to a natural process of wear and aging.

Notes

Bosch Rexroth AG
Industrial Hydraulics
Zum Eisengießer 1
97816 Lohr am Main, Germany
Phone +49 (0) 93 52/40 30 20
my.support@boschrexroth.de
www.boschrexroth.de

© All rights reserved to Bosch Rexroth AG, also regarding any disposal, exploitation, reproduction, editing, distribution, as well as in the event of applications for industrial property rights.
The data specified above only serve to describe the product. No statements concerning a certain condition or suitability for a certain application can be derived from our information. The information given does not release the user from the obligation of own judgment and verification.
It must be remembered that our products are subject to a natural process of wear and aging.

Notes

Bosch Rexroth AG
Industrial Hydraulics
Zum Eisengießer 1
97816 Lohr am Main, Germany
Phone +49 (0) 93 52/40 30 20
my.support@boschrexroth.de
www.boschrexroth.de

© All rights reserved to Bosch Rexroth AG, also regarding any disposal, exploitation, reproduction, editing, distribution, as well as in the event of applications for industrial property rights.
The data specified above only serve to describe the product. No statements concerning a certain condition or suitability for a certain application can be derived from our information. The information given does not release the user from the obligation of own judgment and verification.
It must be remembered that our products are subject to a natural process of wear and aging.